



Technical Service Bulletin

GROUP
RECALL

NUMBER
23-01-081H

DATE
SEPTEMBER 2023

MODEL(S)
KONA (SX2)

SUBJECT:

REAR SEAT BELT RETRACTOR RETAINER FASTENER PIN
INSPECTION AND REPLACEMENT (RECALL 250)

★ IMPORTANT

Vehicle repairs related to safety recalls are critically important and must be performed properly in accordance with TSB procedures. Review this bulletin in its entirety prior to beginning any repair work.

As required by federal law, dealers must not deliver new vehicles for sale or for lease to customers until all open recalls have been performed. Dealers must also perform all open recalls on used vehicles, demo, and rental vehicles prior to placing them into customer use and whenever an affected vehicle is in the shop for any maintenance or repair.

Access the "Vehicle Information" screen via WEBDCS to identify open recalls.

Description: The rear lefthand and righthand seat belt assemblies in the subject vehicles may have undergone improper pin installation, potentially inhibiting extension of the seat belt webbing. An inability to fasten the seat belt in an occupied seat poses a failure to comply with Federal Motor Vehicle Safety Standard ("FMVSS") number 208, "Occupant Crash Protection," and FMVSS number 209, "Seat Belt Assemblies," increasing the risk of injury in a crash.

This bulletin provides the service procedure to inspect the retainer fastener pins and replace the rear seat belt assembly if necessary.

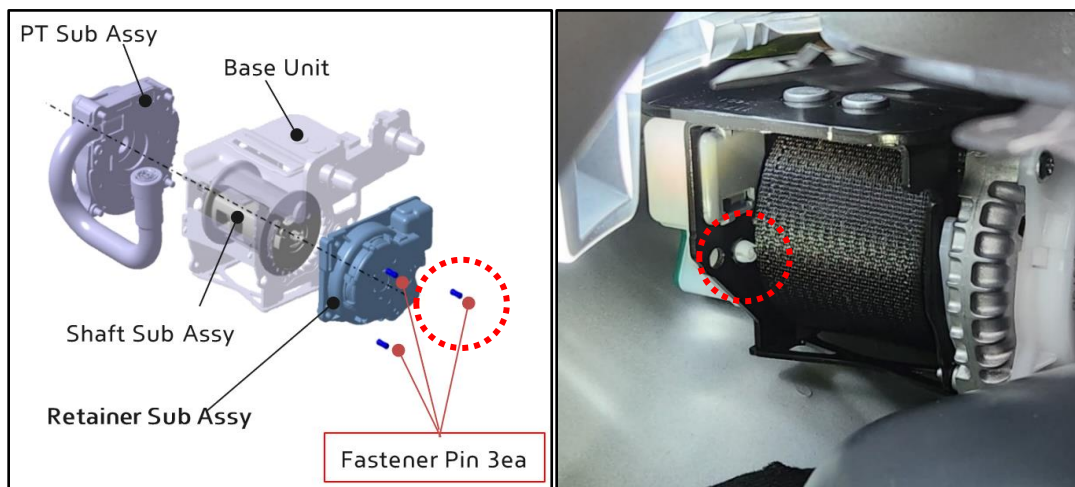

Applicable Vehicles (Certain):

- 2024MY Kona (SX2) vehicles produced between 6/19/2023 – 9/02/2023.

Circulate To: General Manager, Service Manager, Parts Manager, Warranty Manager, Service Advisors, Technicians, Body Shop Manager, Fleet Repair

SUBJECT: REAR SEAT BELT RETRACTOR RETAINER FASTENER PIN INSPECTION AND REPLACEMENT (RECALL 250)

Parts Information:

Part Name	Figure	Part Number	Remarks
REAR SEAT BELT		89870BE-200NNB (LH)	- 1EA - LH
		89880BE-200NNB (RH)	- 1EA - RH
REAR SEAT BUSH		89396-BE000	- 2EA - Replace only if needed, per step 16 on page 10.

SST Information:

Tool Name	Part Number	Figure	Remarks
Borescope	G0DKDNN039		This is an essential tool that has already been shipped to dealers. If dealer has broken or missing components or need a replacement borescope, please contact GITA America at (888) - 437-0308.

Warranty Information:

Model	Op. Code	Operation	Op. Time	Nature Code	Cause Code
Kona (SX2)	31D114R0	REAR SEAT BELT RETRACTOR RETAINER FASTENER PIN CHECK	0.4 M/H	I92	ZZ7
	31D114R1	REAR SEAT BELT RETRACTOR RETAINER FASTENER PIN CHECK AND LH REAR SEAT BELT REPLACEMENT	0.7 M/H		
	31D114R2	REAR SEAT BELT RETRACTOR RETAINER FASTENER PIN CHECK AND RH REAR SEAT BELT REPLACEMENT	0.7 M/H		
	31D114R3	REAR SEAT BELT RETRACTOR RETAINER FASTENER PIN CHECK AND LH/RH REAR SEAT BELT REPLACEMENT	1.1 M/H		

NOTE 1: Submit Claim on Claim Entry Screen as "Campaign" type.

SUBJECT: REAR SEAT BELT RETRACTOR RETAINER FASTENER PIN INSPECTION AND REPLACEMENT (RECALL 250)

NOTE 2: If a part is found in need of replacement while performing this recall and the affected part is still under warranty, submit a separate claim using the same repair order. If the affected part is out of warranty, submit a Prior Approval request for goodwill consideration prior to performing the work.

NOTE 3: This TSB includes Repair validation photos. Op times include VIN, Mileage, and Repair validation photos as outlined in the Digital Documentation Policy.

NOTE 4: The incident parts are subject to callback through the normal Warranty Technical Center (WTC) parts return process. **Claim is subject to debit if the part is not returned.**

SERVICE PROCEDURE:

STUI



This TSB includes Repair validation photos. Refer to the latest Warranty Digital Documentation Policy for requirements.

I. REAR SEAT BELT RETRACTOR RETAINER FASTENER PIN INSPECTION

1. Connect the VCI-II into the vehicle's DLC connector under the driver side instrument panel and connect to the VCI-II on STUI to take pictures using the borescope (A).

Before starting the procedure, make certain that the battery of the Tablet and the borescope are sufficiently charged.



i Information

Review the "STUI Borescope Guide" on hyundaitechinfo.com for connection instructions.

Diagnostic Tools > GDS and STUI Tips > No. 687 STUI Borescope Guide

i Information

For technical assistance or replacement parts, contact GIT America at (888) 437-0308.



P/N: G0DKDNN039

**SUBJECT: REAR SEAT BELT RETRACTOR RETAINER FASTENER PIN
INSPECTION AND REPLACEMENT (RECALL 250)**

2. Remove the center covering shelf (B).

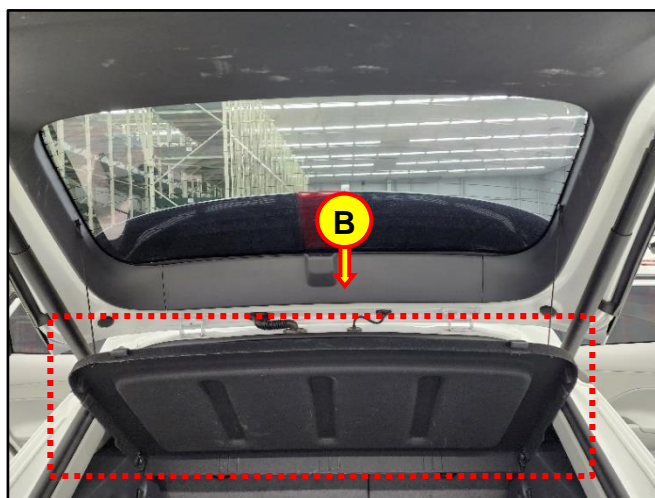

3. Remove the luggage covering mat and luggage board (C) and the rear transverse trim (D).

NOTICE

Wear gloves to prevent injuries to hands.
Be careful not to damage the parts when using a trim remover.
Be careful not to bend or scratch the panels.

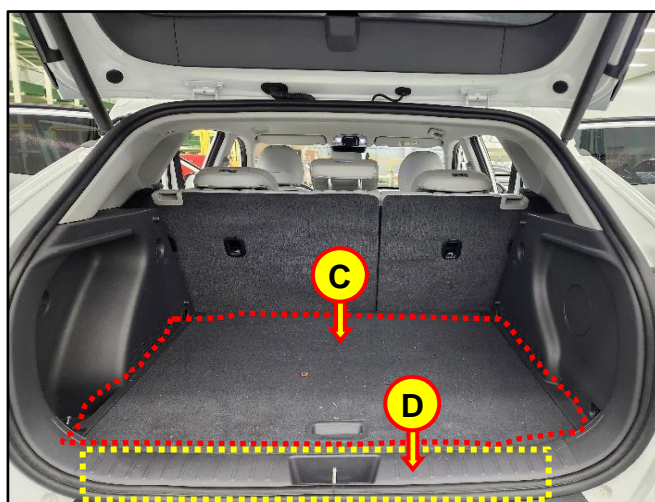

4. Fold the LH/RH rear seat as shown on the right (E).



**SUBJECT: REAR SEAT BELT RETRACTOR RETAINER FASTENER PIN
INSPECTION AND REPLACEMENT (RECALL 250)**

5. Remove the LH luggage side trim fixing screws (F).

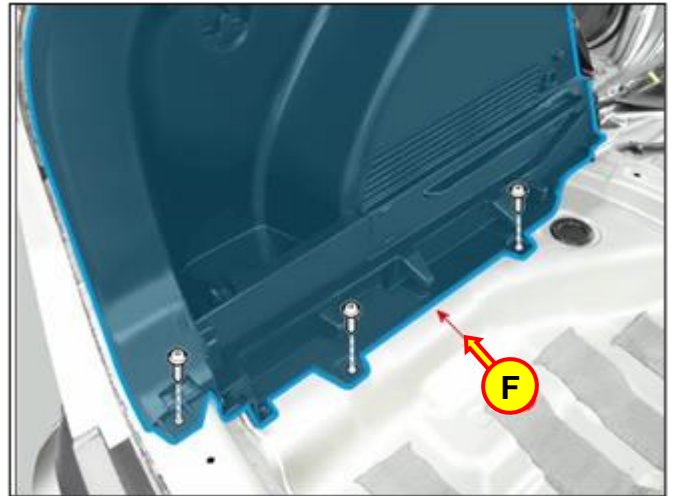

6. Remove the RH luggage side trim fixing screws (G).

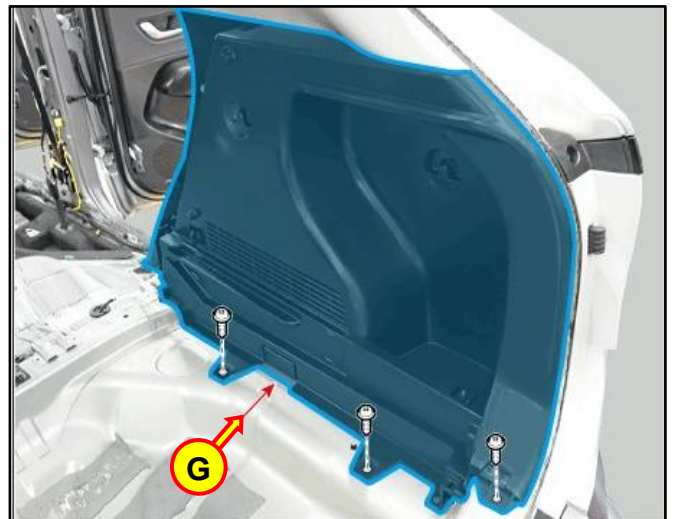

7. Open the LH luggage side trim as shown in the picture on the right to check the mounting of the retainer fastener pin (H) with the borescope camera.

NOTICE

Replace damaged clip(s) with new one(s).

***i* Information**

Attach the 90 degree camera lens on the borescope for best view of the fastener pins. There were two camera lenses (a straight and a 90 degree lens) included in the initial borescope kit to dealers.

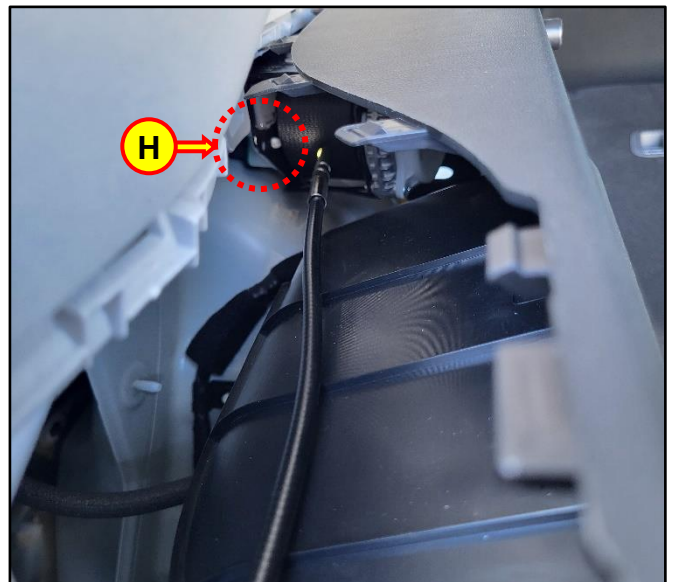

SUBJECT: REAR SEAT BELT RETRACTOR RETAINER FASTENER PIN INSPECTION AND REPLACEMENT (RECALL 250)

8. Using the borescope camera, check the LH rear seat retainer fastener pin (I) is mounted.

i Information

View to the fastener pin is partially obstructed by the seat belt webbing when fully retracted.
Extending seat belt out will provide better visibility to the fastener pin.

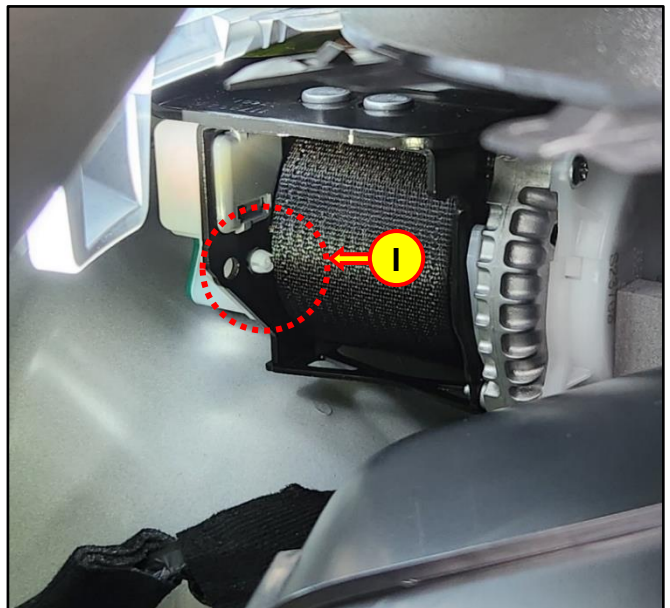

STUI 

Take a photo of the LH rear seat retainer faster pin using the borescope and upload to STUI.



i Information

Only one of the three retainer fastener pins need to be checked on each side to determine if it's good or no good.



**SUBJECT: REAR SEAT BELT RETRACTOR RETAINER FASTENER PIN
INSPECTION AND REPLACEMENT (RECALL 250)**

9. If retainer fastener pins are installed, then reassemble in the reverse order to complete the procedure for the LH.

If fastener pins are missing, follow procedure in Step II to replace the rear seat belt after inspection of RH seat belt fastener pins.

10. Open the RH luggage side trim as shown in the picture on the right and check the mounting of the retainer fastener pin (J) with borescope camera.

NOTICE

Replace damaged clip(s) with new one(s).



11. Check the installation of the RH rear seat retainer fastener pin (K) using the borescope camera.

i Information

Fastener pins are facing the exterior of the vehicle so camera should point towards the interior trim.

Use the 90 degree camera lens on the borescope for best view of the fastener pins.

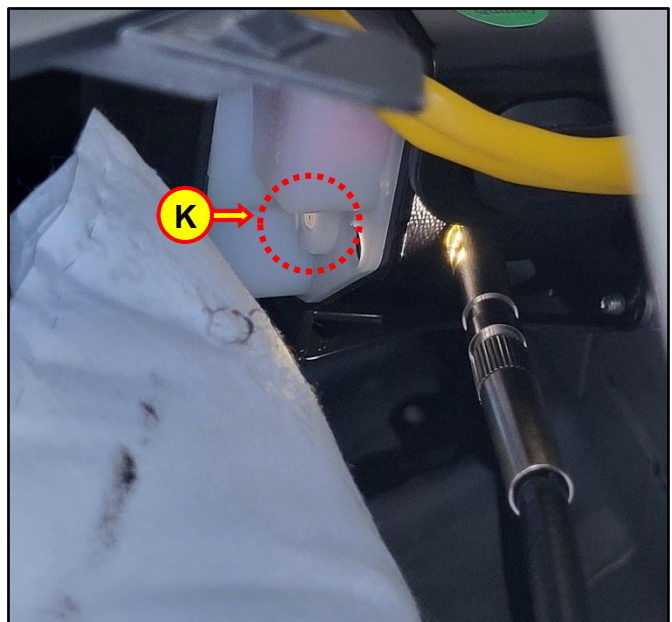



STUI



**Take a photo of the RH rear seat
retainer faster pin using the
borescope and upload to STUI.**

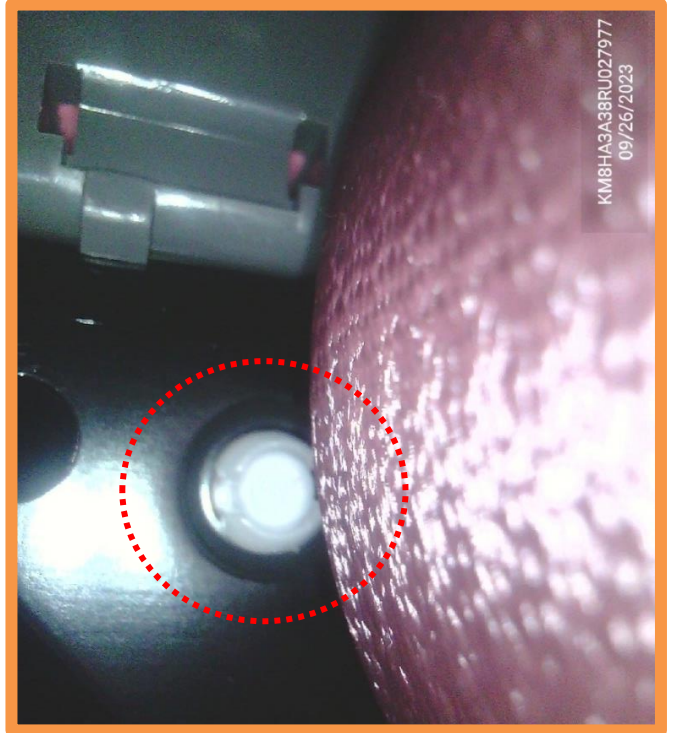

12. If retainer fastener pins are installed, then reassemble in the reverse order to complete the inspection procedure.

Continue to Step II to replace the rear seat belt(s) if necessary.

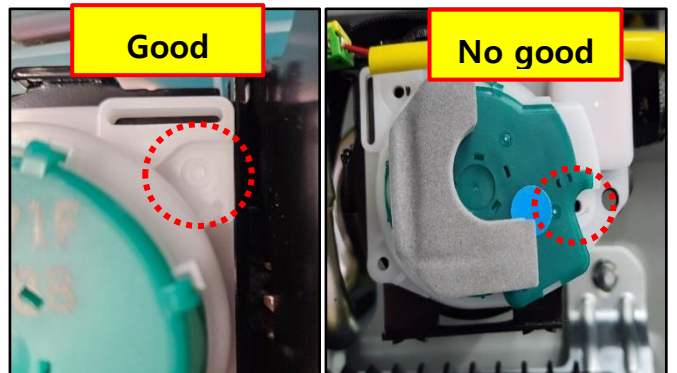

II. REAR SEAT BELT REPLACEMENT PROCEDURE

This procedure shows replacement for the LH side. RH side is the same.

13. Disconnect the battery (-) terminal (A).

Tightening Torque:

lb-ft	5.8 ~ 7.2
kgf.m	0.8 ~ 1.0
N.m	7.8 ~ 9.8

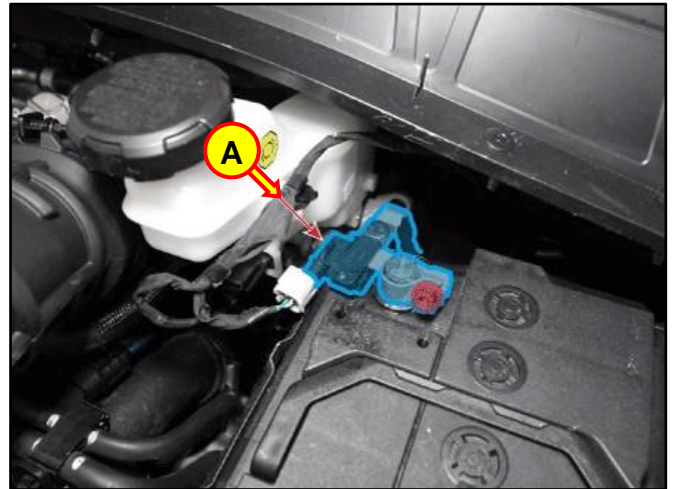

14. Remove the rear seat cushion assembly (B).

Refer to Shop Manual:

- **Body (Interior / Exterior / Electrical) > Rear Seat > Rear Seat Cushion Cover Assembly**

NOTICE

Be careful not to damage, bend, or scratch the parts when using trim remover.



SUBJECT: REAR SEAT BELT RETRACTOR RETAINER FASTENER PIN INSPECTION AND REPLACEMENT (RECALL 250)

15. Remove the bolt and remove the rear seat back assembly (C).

Refer to Shop Manual:

- **Body (Interior / Exterior / Electrical) > Rear Seat > Rear Seat Back Cover Assembly**

Tightening Torque:

lb-ft	32.5~39.8
kgf.m	4.5 ~ 5.5
N.m	44.1~53.9

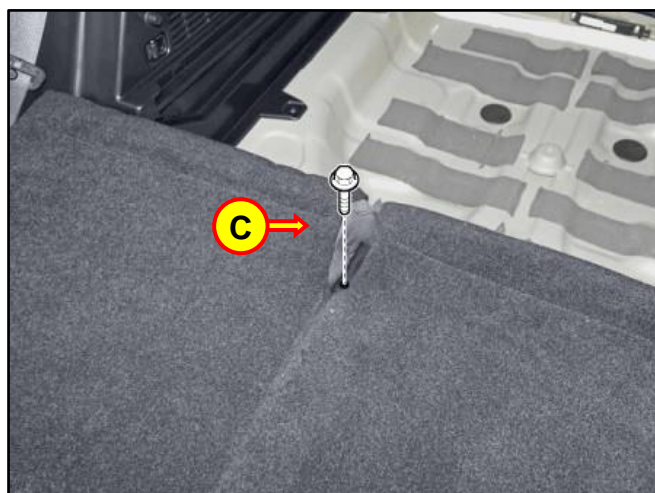

16. Remove the LH/RH rear seat to the side by lifting it in the direction of the right arrow on the picture (D).

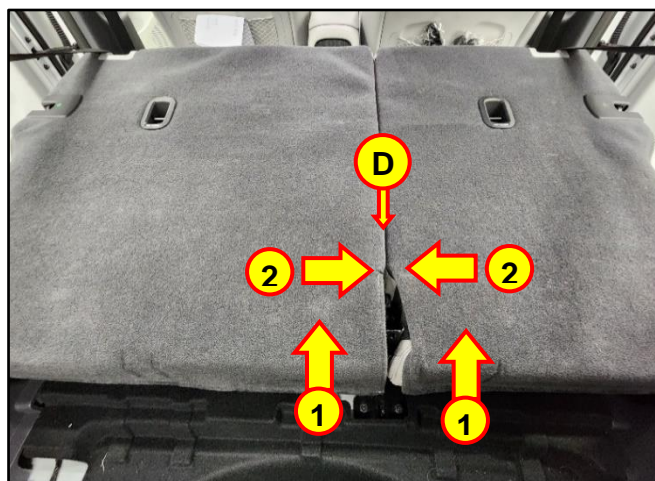

CAUTION

When removing the seat back assembly, be careful not to damage the rear seat bush (E).

Replace with a new supplied rear seat bush if it is damaged during removal.

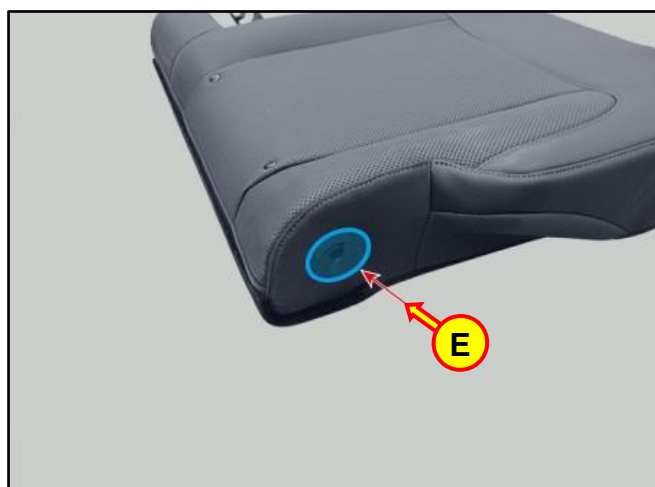

SUBJECT: REAR SEAT BELT RETRACTOR RETAINER FASTENER PIN INSPECTION AND REPLACEMENT (RECALL 250)

17. Remove the luggage side trim.

Refer to Shop Manual:

- **Body (Interior / Exterior / Electrical) > Luggage Trim > Luggage Side Trim**

Remove the mounting bolt and remove the rear seat belt lower anchor (F).

Tightening Torque:

lb-ft	32.5~39.8
kgf.m	4.5 ~ 5.5
N.m	44.1~53.9

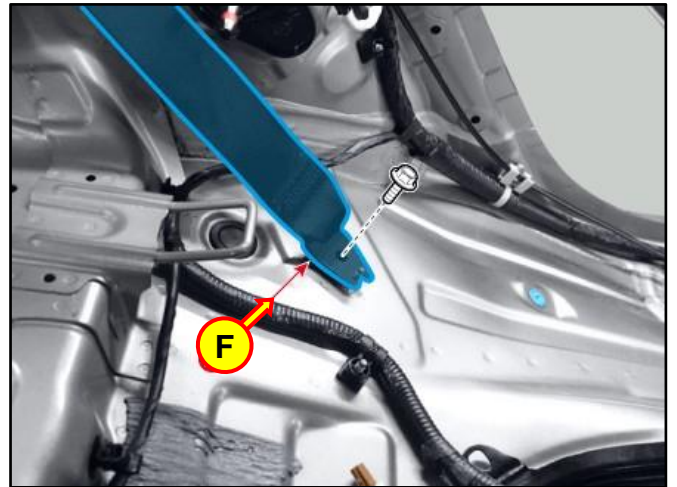

18. Disconnect the rear seat belt retractor connector (G).

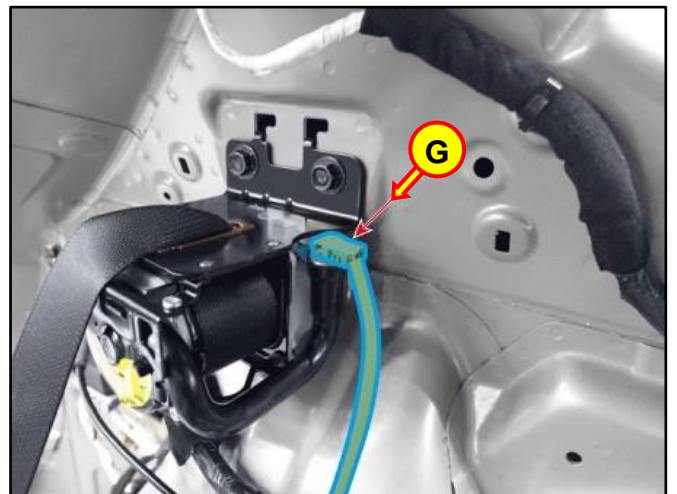

19. Loosen the mounting bolts and remove the rear seat belt retractor (H).

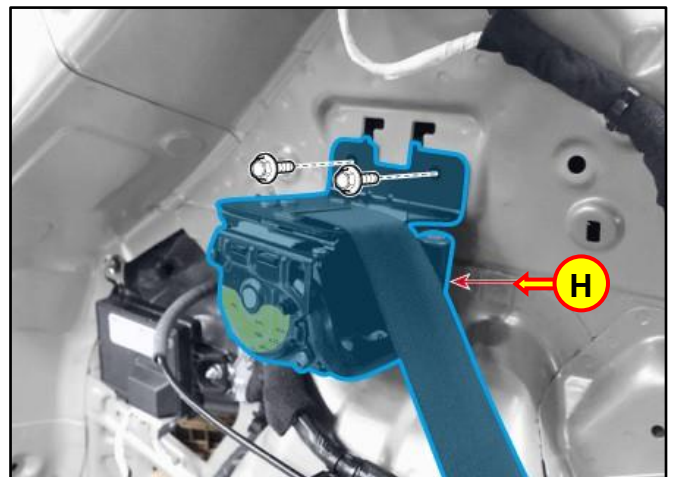

SUBJECT: REAR SEAT BELT RETRACTOR RETAINER FASTENER PIN INSPECTION AND REPLACEMENT (RECALL 250)

20. Replace with supplied rear seat belt retractor.

STUI 

Use STUI, take a photo of the rear seat belt retractor showing the fastener pin with the last 6 digits of the VIN and the date of repair on a piece of paper.

Upload the photo to STUI.

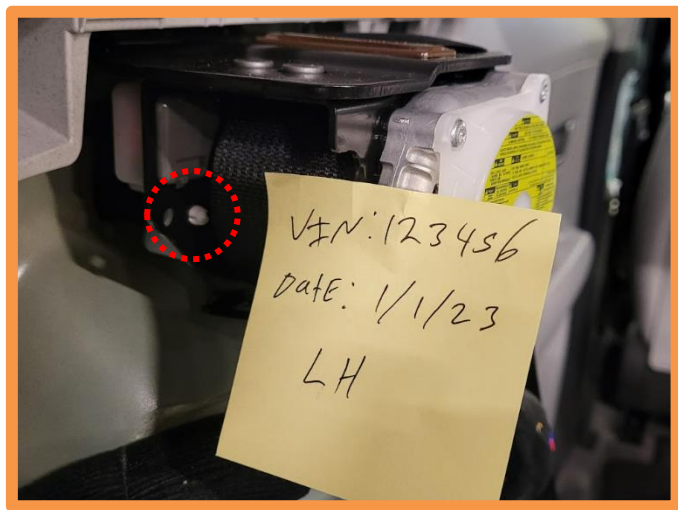

Tightening Torque:

lb-ft	32.5~39.8
kgf.m	4.5 ~ 5.5
N.m	44.1~53.9

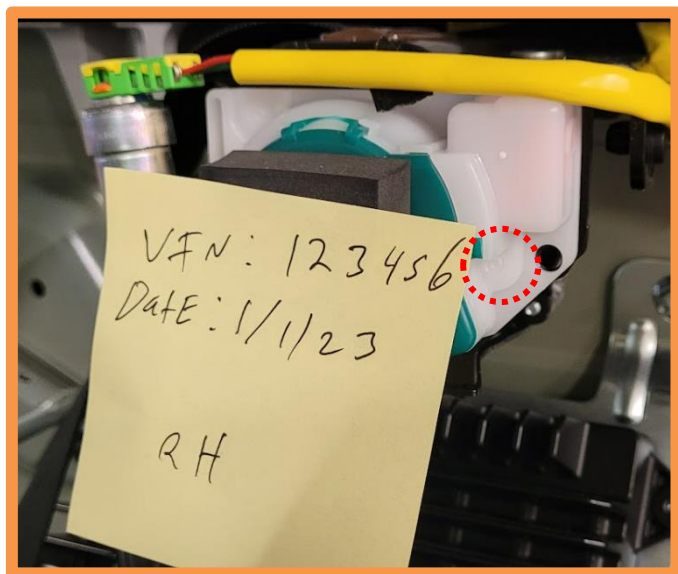

21. Reinstall in reverse order of removal and repeat procedure for RH side if necessary.

Reconnect battery (-) terminal and check functionality of the rear seat belt(s) to complete procedure.