

2023 or newer Ram Promaster Chassis Travato K/KL Awning Rework: Gen 4

Parts required:

RC7927-24-776 Gen 4 K/KL

1. 1.25" Grommet – 114208-07-000 (3)
2. Large zip ties - 008343-04-000(25)
3. Adhesive zip tie mounts - 357004-01-000 (2)
4. Awning Control Module (Gen 2) - 358901-01-000 (1)
5. Wire Asm - Awning – 358843-01-000 (1)
6. 15A Fuse – 062901-05-000 (1)
7. P clamp - 083610-01-000 (3).
8. Small zip ties - 008343-03-000(10)
9. Black Self-tapping screw – 000G39-10-12T (3)
10. Silver Self-tapping screw – 000G39-08-12B (4)
11. Double Sided Tape – 076322-22-000 (4")
12. Screws M4 X 20 – 339810-01-703 (2)
13. Screws #8 x 1", T20 – 339810-01-704 (5)
14. Carefree LH Motor Wedge – 339810-01-709 (1)



2023 or newer Ram Promaster Chassis Travato K/KL Awning Rework:

Read the entire instructions carefully before starting the procedure. If you have any questions, please contact Winnebago Industries Technical Service Department by calling 1-866-653-4329 or by email: techservice@wgo.net. This document is confidential and is intended for dealer use only.

2023 or Newer chassis can be identified by having either a 'P' or preceding letter as the 10th digit of the VIN, or by having both a VSIM module and electronic parking brake.

Tools and Supplies required-

1. Screw gun with #2 Philips and T20 Torx bit.
2. Cutting tool.
3. Cartridge gun.
4. Drill
5. 1.25" Unibit or like tool
6. Fish tape
7. Plastic trim tools
8. Wire stripper/crimper
9. Multi Tester
10. Adhesive surface prep
11. Manus Sealant – 185987-03-02A or equivalent
12. Electrical Tape
13. Metal primer – not shown



Step 1 – Pre-rework Prep

1. Disconnect the shore power cord from the coach – See Image 1.
2. Turn off the house disconnect switch – See Image 2.
3. Disconnect the 12v chassis battery ground. Refer to the Promaster user manual to disconnect the ground cable from the battery.
4. NOTE: If the chassis battery ground is not disconnected before performing the rework, chassis faults may occur that will require a Promaster service center. This cost is not covered under this recall.

Image 1



Image 2



Step 2 – Installing New Harness

1. Locate and remove the passenger side stepwell covers using a screw gun with Philips bit, see Image 1.
2. Using the Unibit, drill a 1.25" hole going through the chassis as shown, see Image 2 red arrow. The hole should be at most 1" away from the vertical walls. Prime the bare metal around the cut hole to prevent rust.
3. Mount the new Awning Control Module using self-tapping screws on the vertical wall of the stepwell closest to the seat, see Image 3. Creating a pilot hole may assist with the installation and avoid damage to the relay board.
4. Connect the 12-pin plug on the new harness to the Awning Control Module.
5. IMPORTANT: The switch on the Awning Control Module controls needs to be set to GROUND– See Image 4.
 - o Setting the switch to GROUND will auto retract the awning when the engine is started.
 - o 12VDC would disable the auto retract function.

Image 1



Image 2

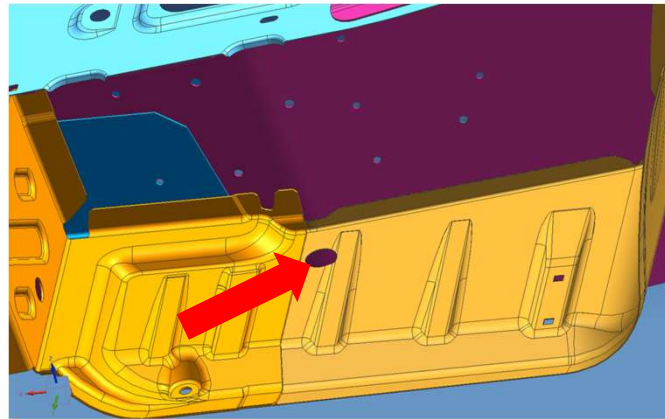

Image 3

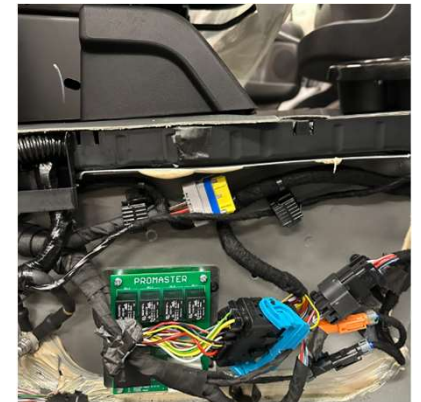

Image 4



Step 2 – Installing New Harness (Cont.)

1. Pop out the center cup holder and screw covers from the center console plastic enclosure. It is held in with clips.
2. Using a screw gun with a T20 Torx bit and trim tools, remove the 4 mounting screws and pop the clips to detach the center console plastic enclosure from the chassis, see Image 1. Only enough room to access the VSIM module is required.
3. Unmount the VSIM module from the chassis by depressing the mounting tab with a flathead screwdriver, see Image 2.
4. Route the wire wrapped section of the harness with 3 multi pin plugs up under the wheel well plastic trim and flooring, beneath the glovebox, behind the passenger kick cover, and back behind the center console area. See Image 3 and 4, yellow arrows. Secure harness and ensure that the harness is not visible to the user.
5. Connect the three plugs from the new harness to the VSIM module, there is only one female connector in the module that will allow each male connector on the harness.
6. Reinstall the VSIM module and the center console plastic enclosure. Any excess wiring on the new harness can be pulled through the 1.25" hole while ensuring no excess stress is on the 12-pin housing on the awning control module. Cut a split into a 1.25" grommet, install it on the harness, and then into the floor from above.

Image 1



Image 2



Image 3



Image 4



Step 2 – Installing New Harness (Cont.)

1. On the coach interior, remove the top panel of the passenger side bed cabinet to gain access to cabinet.
 - a) Disconnect the head of the gas strut by using a flat head screwdriver, see Image 1. The mattress can be removed for better access.
 - b) Remove all mounting screws between the top panel and the rest of the cabinet. Behind the bed frame there are pairs of screws along the back edge, only the indicated screws need to be removed, see Image 2 red arrow. On the left side of the bed, one rib of the bed frame may have to be removed to access the mounting screws, see Image 3.
 - c) Remove the panel assembly from the coach and set aside for reinstallation.
2. With the panel now removed, go below the coach and drill a 1.25" hole up into the bed cabinet, see Image 4 red arrow. The new hole should be about 3" towards the coach exterior compared to the original and should stay out of the existing Manus. Ensure when drilling that no wiring inside the bed cabinet will be damaged. Prime the bare metal around the cut hole to prevent rust.
3. Bring the new harness up through the 1.25" hole until there is no excess harness outside of the coach. Cut a split into a 1.25" grommet, install it on the harness, and then into the floor from above.
4. Secure the new harness up to the existing Winnebago harnesses using zip ties or to the chassis rib using P clamps. See Images 5 and 6, yellow arrows for the wire path. The new harness should not be allowed to sag below the existing harnesses. The 1.25" holes in the chassis can be filled with Manus to prevent water intrusion.

Image 5



Image 6



Image 1



Image 2



Image 3

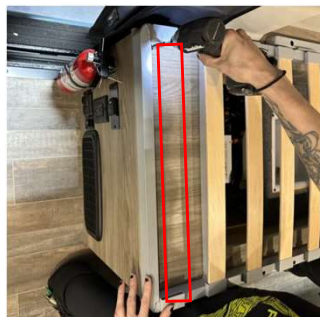

Image 4



Step 2 – Installing Harness with Recall 168

1. Some coaches may have recall 168 previously completed . This can be identified visually through the addition of the harness in Image 1 installed between the BT-12 and the awning switch.
 - The Part Number printed on the wires should be 000270094
2. If this harness is present, cut all connections and remove the harness.
 - Note: Because the harness is running up to the BT-12, it may be useful to tape the new harness to a section of the recall 168 harness and pull it through.
3. The continuity of the TD circuit on the original harness should be restored. This can be done using 1TD and 2TD on the New Harness.
 - If this is done, any following references to connecting TD can be disregarded.
4. Follow the proceeding pages for the other new connections.

Image 1

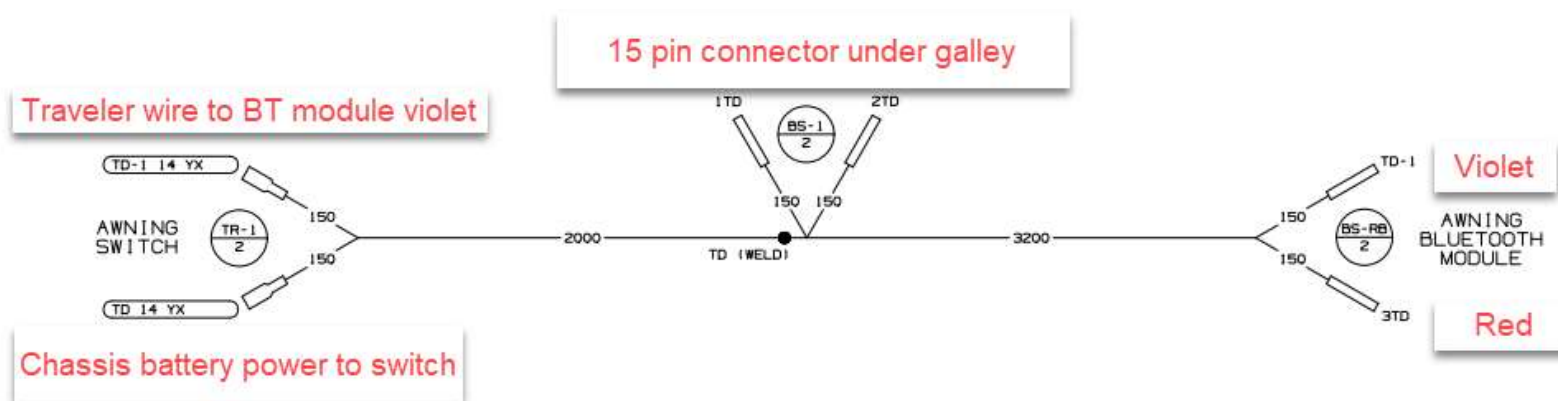

Step 2 – Installing New Harness (Cont.)

1. Connect the branch FFT and FFT-1 spade connector on the new harness to the awning on/off switch in place of the current connections. see Image 1 and 2 red arrows.
2. Remove the jumper from the new harness and discard.
3. Leave TD on the new harness disconnected, this will be connected later once power is restored. All other connections from the original harnesses that are not labeled TD in this area can be taped up.
4. Take NM, AWP, ASY, and FFT-1 from the new harness and route them back through the bed cabinet towards the rear of the coach.
5. Connect the spade connector on NM to Space 6 on the back of the fuse panel. Install a 15A fuse on the front of the panel into space 6 and label this fuse "Awning". See Image 3 red arrow. Removal of the fuse panel may be necessary for proper access.
6. Remove the abs closeout in the upper corner of the shirt cabinet. This should expose the BT-12 unit and its connections. See Image 4 red arrow.
7. Using fish tape, route AWP, ASY, and FFT-1 up to the BT-12 by having it pass behind the drawer and behind the shirt closet paneling. See Image 5 and 6 red arrows for wire path. The access panel and drawer can be removed for better access, as necessary.

Image 5

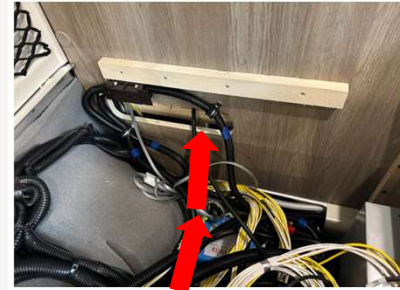

Image 1

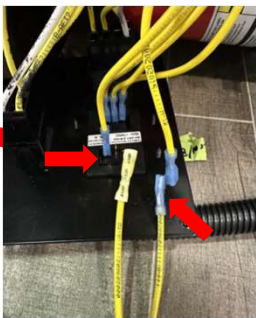

Image 2



Image 3

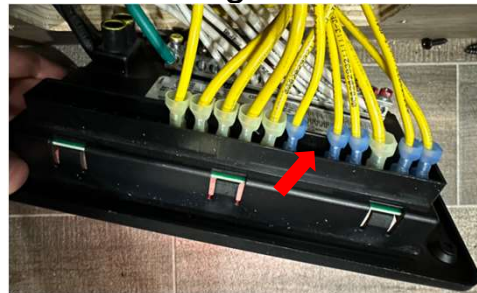

Image 4



Image 6



Step 3 – BT-12 Connection

1. Cut the current connection to the red, green, and violet wires of the BT-12 module. Wrap these original circuits with tape, they will no longer be used.
2. Splice the below connections from the new harness to the BT-12:
 - AWP to Red
 - ASY to Green
 - FFT-1 to Violet
3. Check the wiring connections at the BT-12 module and verify that every circuit is properly connected. See Image 1 or the Wiring Diagram –BT-12 page at the back of this packet for proper connections.
4. Use the adhesive on the BT-12 to permanently mount to the ceiling in the shirt cabinet's closeout, see Image 2 Red Arrow. Ensure the wires come down creating a drip loop. Secure wire with additional wire ties as needed to create strain relief and ensure drip loop, see Image 2 Yellow Arrow.
5. Reinstall the closeout panel, fuse panel, bed panel and bed, and the passenger stepwell cover.

Image 1

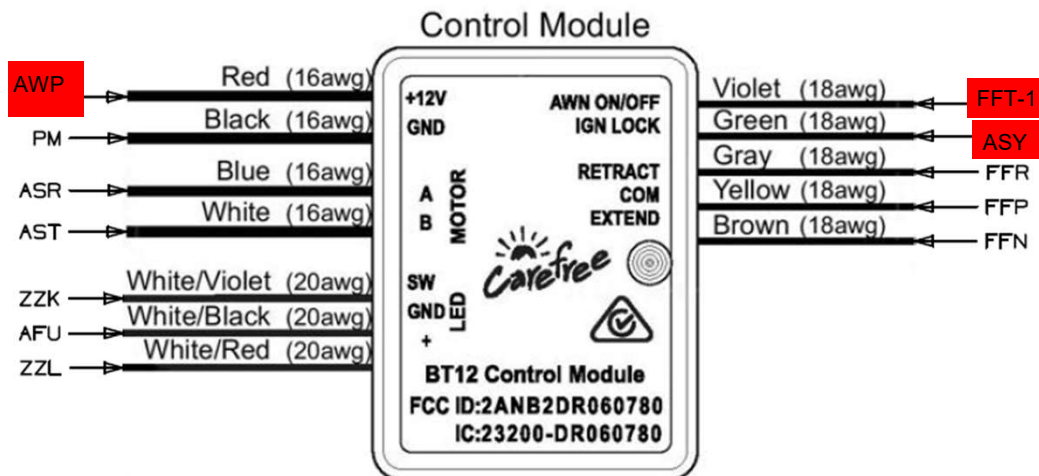
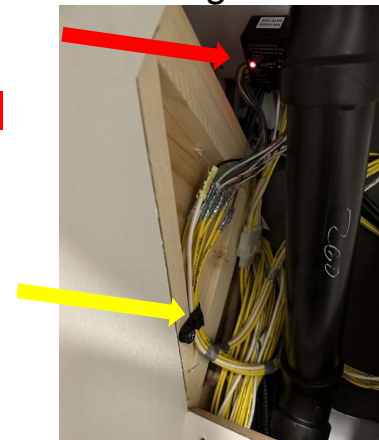

Image 2



Step 4 – Seal Awning Wire Passthrough

1. Go to the coach roof and locate the wiring on the awnings left hand side.
2. Remove electrical tape wrap without damaging wires to gain access to the interior of the convolute tubing, see Image 1.
3. Insert nozzle of cartridge gun into convolute tubing as far into the coach as you can, seal the inside tubing back to 2 inches up from the roof, see Image 2. Ensure sealant oozes out to confirm the convolute is fully filled. Wipe off excess, prep, and retape convolute starting from the roof and wrapping up to the awning creating a shingled effect. See Image 3
4. Using Manus, reseal on top of the existing self-leveling around the base of the convolute and tool to ensure no gaps are present, see Image 4.

Image 1



Image 2

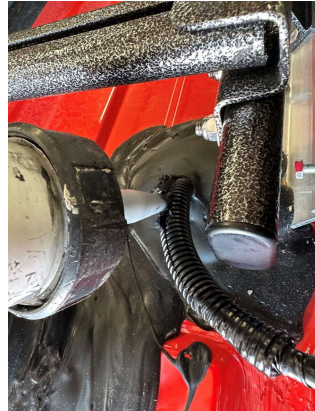

Image 3

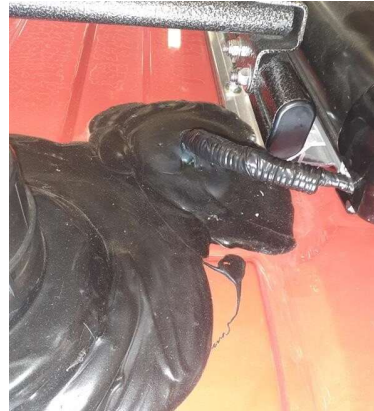

Image 4



Step 5 – Reconnect the 12v power sources.

1. Turn on the 12v house disconnect switch – See Image 1.
2. Reconnect the 12v chassis battery ground. Refer to the Promaster user manual to disconnect the ground cable from the battery.

Image 1



Step 6 – TD Connection

1. In the bed cabinet near the awning switch, locate the circuits labeled TD on the existing harnesses.
2. Using a multimeter, test these circuits to find one that shows 12v power now that chassis power is restored.
3. Note: Some of the existing TD circuits, either on the original harness or rework harnesses, may have been fully disconnected during the recall and will no longer carry chassis power. These circuits can be taped off or removed as they are no longer a useable connection.
4. Splice the new harness to one of the hot TD circuits. See image 1 yellow arrow.

Image 1



Step 7 – Awning Motor wedge and firmware update

1. Before performing the motor wedge installation, confirm that the awning installed requires a wedge, and that one is not already installed. When inspecting the awning be sure to check both sides for the motor, as depending on build it may be a right-hand or left-hand motor.
 1. Confirm that the awning is an angle gear motor, this style of motor is the one that requires the wedge. See Image 1 for an example of what the angle gear motor looks like with the awning extended. Tubular style motors, where the motor is housed inside the awning fabric roller, do not require a wedge.
 2. If the awning is an angle gear motor, gain access to the backside of the motor by removing the case end cap, see Image 2. Some coaches may require the mounting screws be removed and the awning to be slid back on the mounting extrusion in order to access the cover. When doing this be careful to not pop the awning out of the mounting extrusion as it could fully detach from the coach.
 3. Confirm that a wedge is not installed, Image 3 shows a motor with a wedge already installed.
 4. If your coach does not have the wedge and requires one, move onto the next page and follow the wedge installation.

Image 1



Image 2



Image 3



Step 7 – Awning motor wedge and firmware update(Cont.)

1. Review and complete the following documents, all units with a BT-12 require a firmware update.
 - Carefree Motor Wedge Installation service manual, 056513-002R1(LH) or 056513-001R5(RH) . (For angle gear awnings without a wedge already installed)
 - Carefree Connects Firmware Update service manual, 056513-004r1 (All awning with a BT-12)



Step 8 – System Testing

- See the chart in Image 1 and confirm that all 'With' situations result in the correct actions when the extend and retract commands are operated.
 - Note:** awning will need to be partially extended to confirm auto-retraction, see Image 2.
 - Note:** the relay module will hold the park brake signal from when the park brake is engaged until the engine is started or the module loses power. This is due to the chassis going to sleep and needing to hold the park brake signal.
- With the engine off and the parking brake and 12v coach power on, bring the awning to a partially extended position, see Image 2. Locate the edge of the awning with the wind sensor and shake the awning to simulate high winds. The awning should automatically retract when the sensor reads the awning movement.
- If all the above actions result in their defined outcomes the rework is complete.

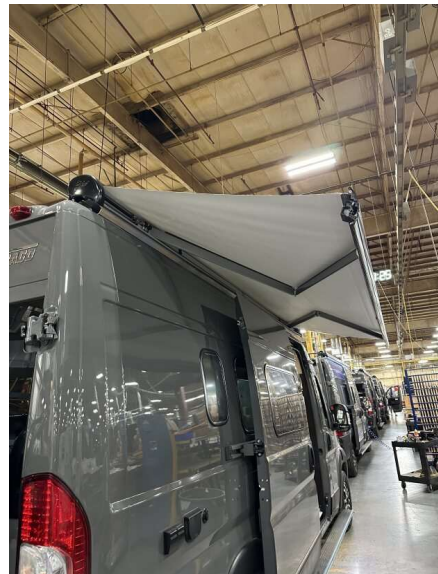
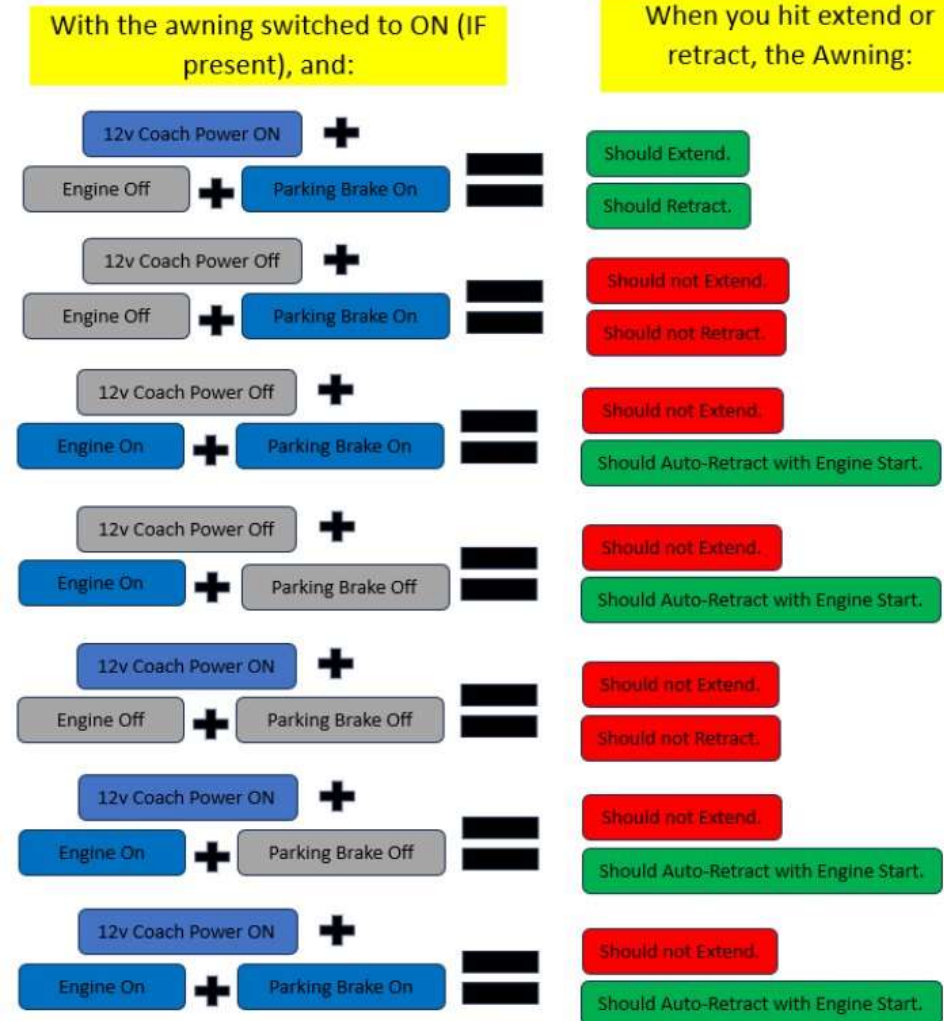

Image 2

Image 1



Blank Slide-

Wiring Diagram – Carefree BT-12

BT-12 Wiring Diagram

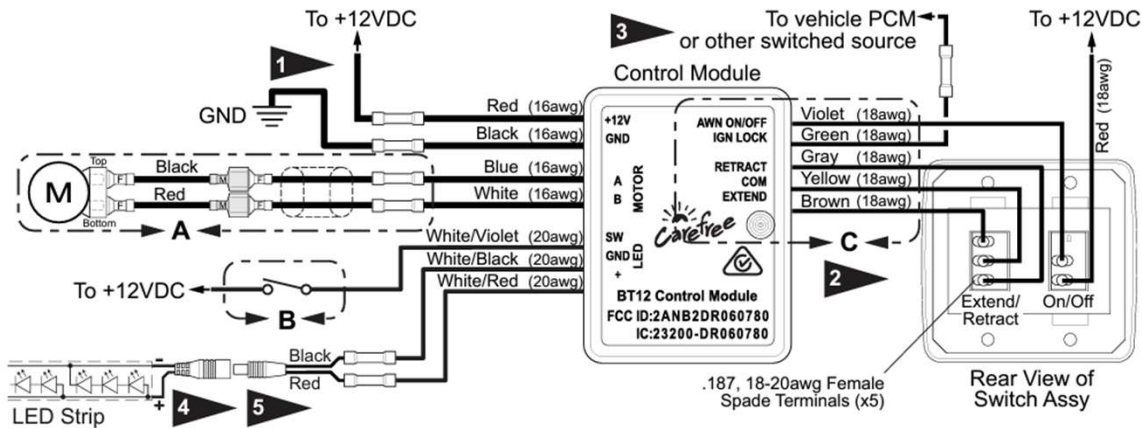

BT-12 to WGO Harness Connections

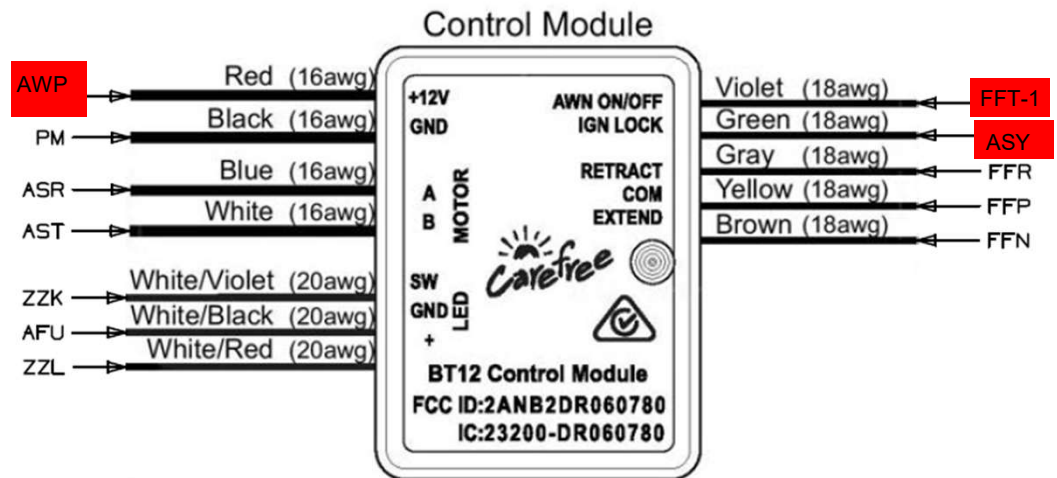

Wiring Diagram – Harness

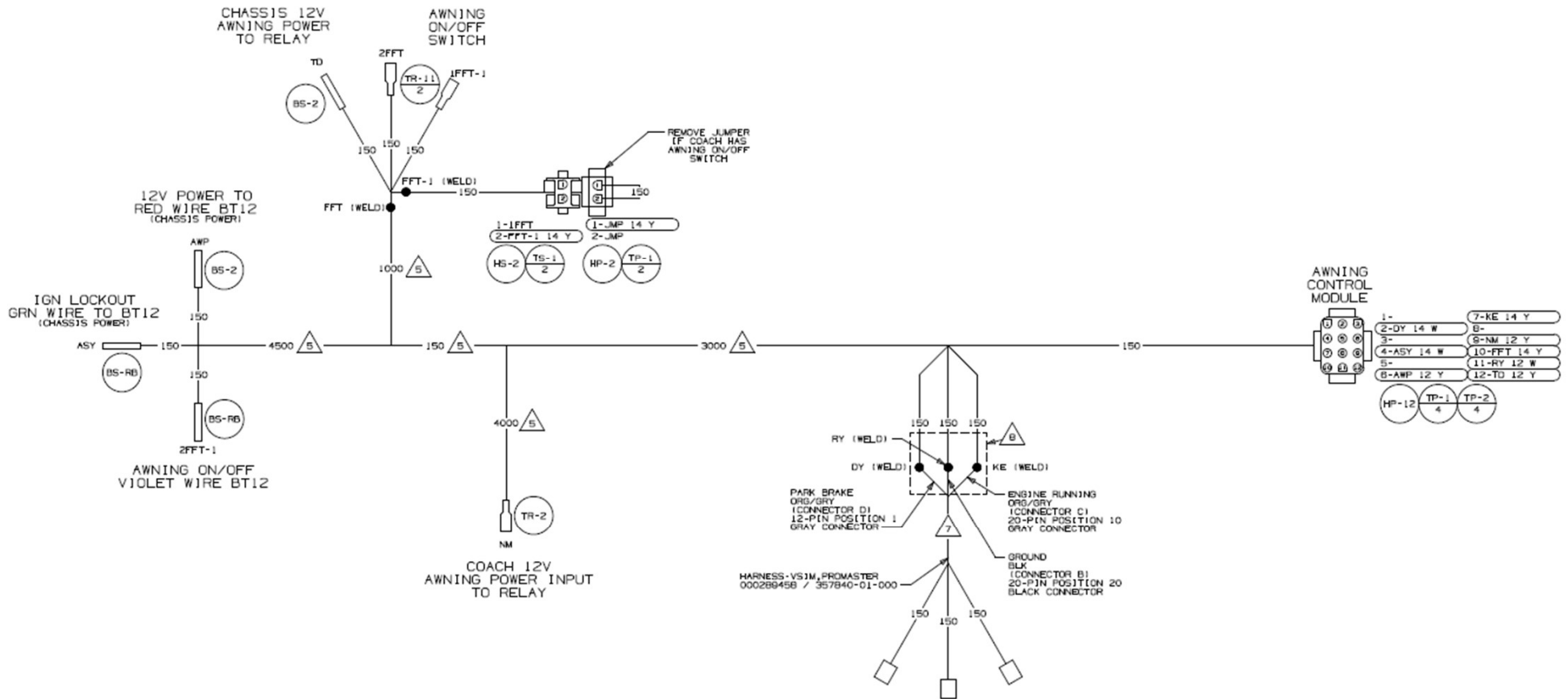

WIRE ASM-AWNING UPDATE

Read the entire instructions carefully before starting the procedure. If you have any questions, please contact Winnebago Industries Technical Service Department by calling 1-866-653-4329 or by email: techservice@wgo.net. This document is confidential and is intended for dealer use only.