

2022 Ram Promaster Chassis Travato G/GL Awning Rework: Gen 3

Parts required:

RC7923-24-776 Gen 3 G/GL

1. 1.25" Grommet – 114208-07-000 (3)
2. Large zip ties - 008343-04-000(25)
3. Adhesive zip tie mounts - 357004-01-000 (2)
4. Awning Control Module (Gen 2) - 358901-01-000 (1)
5. Wire Asm - Awning – 358863-01-000 (1)
6. 15A Fuse – 062901-05-000 (1)
7. P clamp - 083610-01-000 (3).
8. Small zip ties - 008343-03-000(10)
9. Black Self-tapping screw – 000G39-10-12T (3)
10. Silver Self-tapping screw – 000G39-08-12B (4)
11. Double Sided Tape – 076322-22-000 (4")
12. Ring Terminal - 326278-01-000 (1)
13. Screws M4 X 20 – 339810-01-703 (2)
14. Screws #8 x 1", T20 – 339810-01-704 (5)
15. Carefree LH Motor Wedge – 339810-01-709 (1)
16. Interface Module - 358822-01-000 (1)

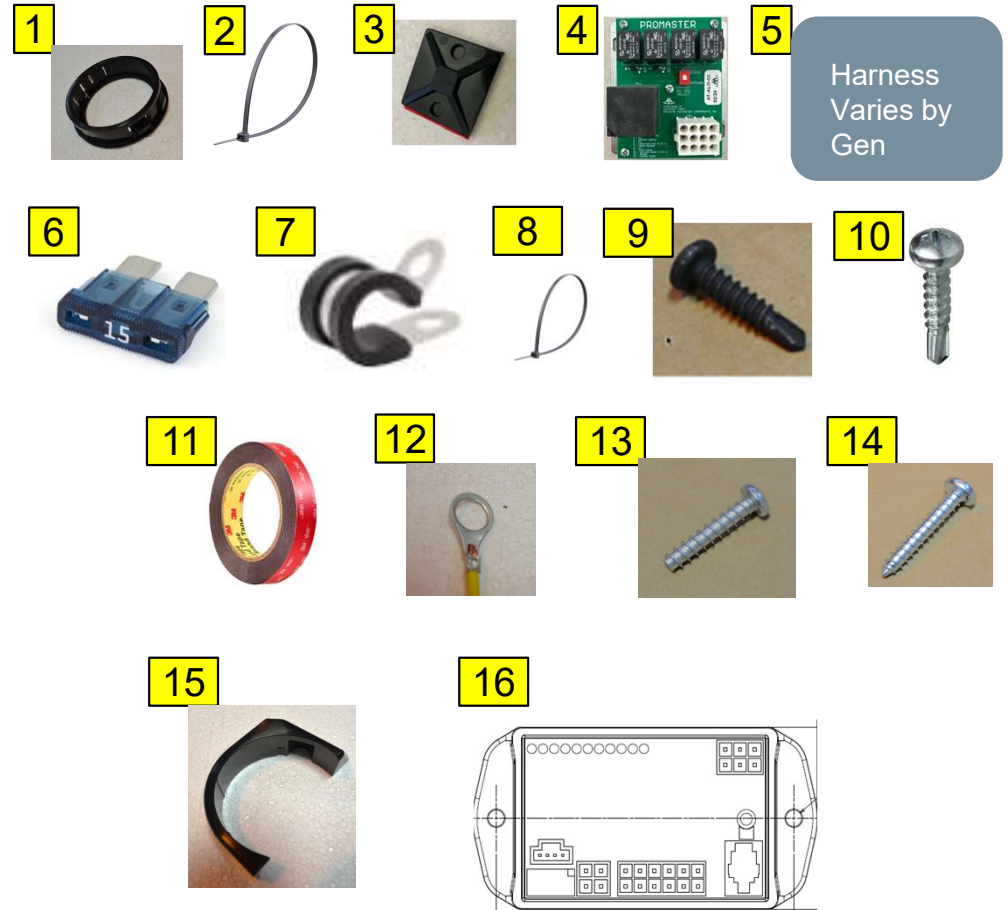

2022 Ram Promaster Chassis Travato G/GL Awning Rework:

Read the entire instructions carefully before starting the procedure. If you have any questions, please contact Winnebago Industries Technical Service Department by calling 1-866-653-4329 or by email: techservice@wgo.net. This document is confidential and is intended for dealer use only.

2022 can be identified by having either a 'N' as the 10th digit of the VIN, or by not having a VSIM module and having an electronic parking brake.

Tools and Supplies required-

1. Screw gun with #2 Philips and T20 Torx bit.
2. Cutting tool.
3. Cartridge gun.
4. Drill
5. 1.25" Unibit or like tool
6. Fish tape
7. Plastic trim tools
8. Wire stripper/crimper
9. Multi Tester
10. Adhesive surface prep
11. Manus Sealant – 185987-03-02A or equivalent
12. Electrical Tape
13. Low profile 90-degree drive
14. Metal primer – not shown



Step 1 – Pre-rework Prep

1. Disconnect the shore power cord from the coach – See Image 1.
2. Turn off the house disconnect switch – See Image 2.
3. Disconnect the 12v chassis battery ground. Refer to the Promaster user manual to disconnect the ground cable from the battery.
4. NOTE: If the chassis battery ground is not disconnected before performing the rework, chassis faults may occur that will require a Promaster service center. This cost is not covered under this recall.

Image 1



Image 2



Step 2 – Installing New Harness

1. Locate and remove the passenger side stepwell covers using a screw gun with Philips bit, see Image 1.
2. Using the Unibit, drill a 1.25" hole going through the chassis as shown, see Image 2 red arrow. The hole should be at most 1" away from the vertical walls. Prime the bare metal around the cut hole to prevent rust.
3. Mount the new Awning Control Module using self-tapping screws on the vertical wall of the stepwell closest to the seat, see Image 3. Creating a pilot hole may assist with the installation and avoid damage to the relay board.
4. Connect the 12-pin plug on the new harness to the Awning Control Module.
5. IMPORTANT: The switch on the Awning Control Module controls needs to be set to GROUND– See Image 4.
 - o Setting the switch to GROUND will auto retract the awning when the engine is started.
 - o 12VDC would disable the auto retract function.

Image 1



Image 2

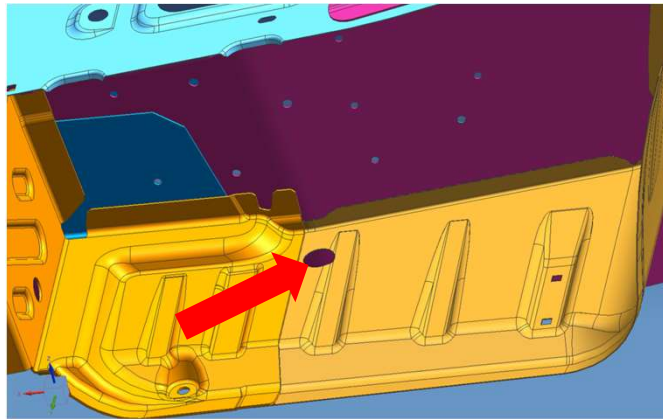

Image 3

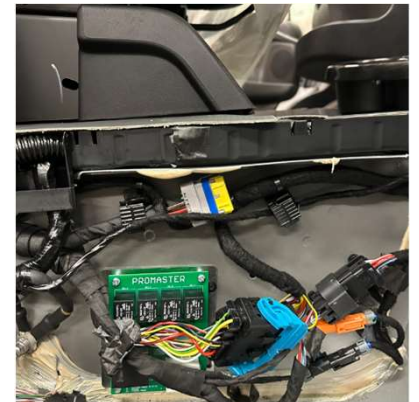

Image 4



Step 2 – Installing New Harness (Cont.)

1. Locate and remove the four T20 screws holding in the top of the glove box assembly. The fourth screw is below the right passenger air vent. See image 1 yellow arrows.
2. Pop the two release tabs, one on either side of the glove box and allow it to drop down. See image 2 yellow arrows.
3. Loosen or remove the two T20 screws behind the glove box tray securing the assembly, see image 2 blue arrows.
4. At this point, only clips retain the glove box assembly. Use your hands or plastic trim tools to detach it from the chassis.
5. Locate the Ram Gateway module mounted on the back of the glove box assembly. See image 4.
6. Remove the 12-pin and 8-pin connectors from the Gateway module and plug in the 12-pin and 8-pin connectors from the Intermotive Interface Module harness. Plug the RAM 12-pin and 8-pin connectors into the mating connectors on the Interface Module harness. See image 4.
7. Plug the free end of the 6-pin Data Link harness into the mating 6-pin connector on the 4 foot extension harness.
8. Reinstall the glove box assembly.

Image 1



Image 2



Image 4



Step 2 – Installing New Harness (Cont.)

1. Pop out the center cup holder and screw covers from the center console plastic enclosure. It is held in with clips.
2. Using a screw gun with a T20 Torx bit and trim tools, remove the 4 mounting screws and pop the clips to detach the center console plastic enclosure from the chassis, see Image 1.
3. Route the section of the new Winnebago harness with the 2X6 CAN plug up under the wheel well plastic trim and flooring, beneath the glovebox, behind the passenger kick cover, and back behind the center console area. See Image 2 and 3, yellow arrows.
4. Route the Interface Module extension harness behind the passenger kick cover and back behind the center console area.
5. Secure harnesses and ensure they are not visible to the user.
6. Mount the Interface Module to the chassis using VHB tape. Connect the plug from the extension harness and the new Winnebago harness to the CAN Interface Module. See Image 4.
7. Any excess wiring on the new Winnebago harness can be pulled through the 1.25" hole while ensuring no excess stress is on the 12-pin housing on the awning control module. Cut a split into a 1.25" grommet, install it on the harness, and then into the floor from above.

Image 1



Image 2

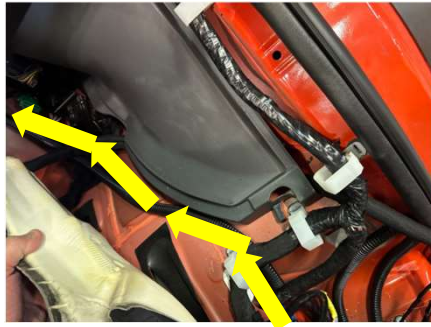

Image 3



Image 4



Step 2 – Installing New Harness (Cont.)

1. On the coach interior, gain access to the galley cabinet interior by removing the drawers.
2. Gain access to the area behind the fuse panel in the bed cabinet. This can be done by removing the drawer above the fuse panel and unmounting the fuse panel itself. See Image 1.
3. Below the coach, drill a 1.25" hole up into the galley cabinet. This hole should be 4" towards the front of the coach as compared to the existing 2" wire routing hole. See Image 2, red arrow. Ensure when drilling that no wiring inside the Galley cabinet will be damaged. Prime the bare metal around the cut hole to prevent rust.
4. Below the coach, drill a 1.25" hole up into the bed cabinet, see Image 3 red arrow. The new hole should be in the edge of the last section of rib right next to the driver side leaf spring's forward pivot. Ensure when drilling that no wiring inside the bed cabinet will be damaged. Prime the bare metal around the cut hole to prevent rust.
5. Route the new harness from the passenger stepwell back through the LP manifold mounting bracket. Bring the new harness branch with AWP, TD, ASY, and FFT up into the Galley cabinet 1.25" hole. See Image 5, red arrows. Cut a split into a 1.25" grommet, install it on the harness, and then into the floor from above.
6. Route the new harness branch NM through the grey tank mounting brackets, over the rearward battery, and into the new bed cabinet 1.25" hole. See Image 4 and 6, red arrows. Cut a split into a 1.25" grommet, install it on the harness, and then into the floor from above.
7. Secure the new harness up to the existing Winnebago harnesses or chassis mounting holes using zip ties or to the chassis rib using P clamps. See Images 4, 5 and 6, yellow arrows. The new harness should not be allowed to sag below the existing harnesses. The 1.25" holes in the chassis can be filled with Manus to prevent water intrusion.

Image 5

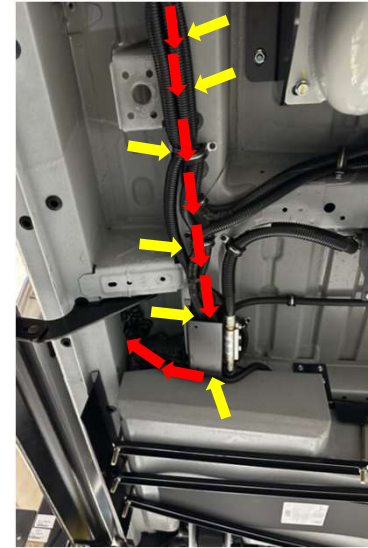

Image 1



Image 2

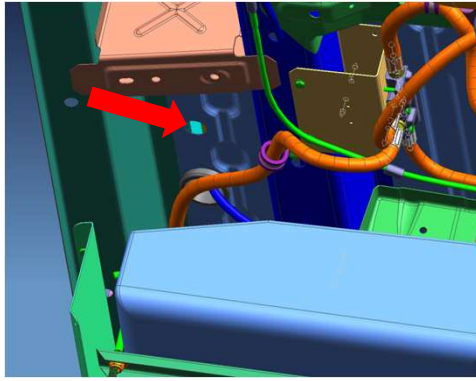

Image 3



Image 4



Image 6

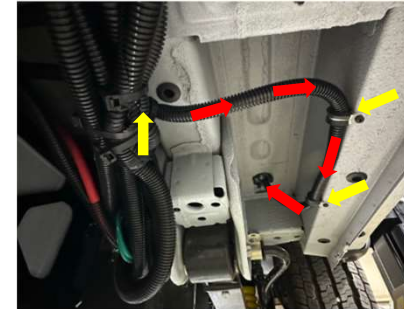

Step 2 – Installing New Harness (Cont.)

1. Partially unmount the abs closeout panel above the sliding door. The closeout panel is secured to the roof, sidewall rib, and screen door. Only remove screws as needed to pull away panel, the BT-12 and its connections should now be accessible. See Image 1 for screw locations.
2. Take AWP, ASY, and FFT-1 of the new harness and route it behind the cabinet, up through the plastic trim at the rear of the sliding door, and up to the BT-12. There is a recessed path that allows the wire to pass through without interfering with the abs panel fitment, see Image 2 and 4 red arrows for wire path. Use trim tools as needed to pry the panels away and fish tape to bring the circuits up, see Image 3. The sliding door seal can be removed for easier access.

Image 1



Image 2



Image 3



Image 4



Step 2 – Installing Harness with Recall 168

1. Some coaches may have recall 168 previously completed . This can be identified visually through the addition of the harness in Image 1 installed between the BT-12 and the awning switch.
 - The Part Number printed on the wires should be 000270094
2. If this harness is present, cut all connections and remove the harness.
 - Note: Because the harness is running up to the BT-12, it may be useful to tape the new harness to a section of the recall 168 harness and pull it through.
3. The continuity of the TD circuit on the original harness should be restored. This can be done using 1TD and 2TD on the New Harness.
 - If this is done, any following references to connecting TD can be disregarded.
4. Follow the proceeding pages for the other new connections.

Image 1

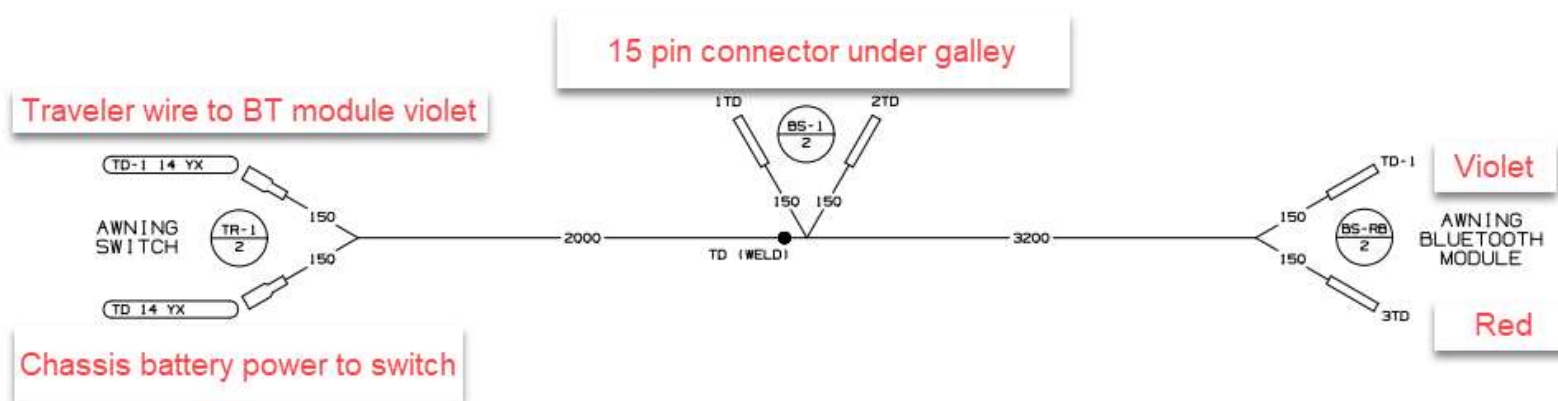

Step 2 – Switch Connection W/ Carefree Switch

1. If the coach is equipped with the Carefree awning on/off switch, follow the below steps. Otherwise move onto the next page.
2. Connect the branch FFT and FFT-1 spade connector on the new harness to the awning on/off switch in place of the current connections. see Image 1 red arrows.
3. Remove the jumper from the new harness and discard. See Image 2.
4. Leave one of the TD connections on the new harness untaped and disconnected, this will be connected later once power is restored.
5. The remaining TD wire connection on the new harness will not be used, it can be taped up along with all other connections on the original harnesses in this area that are not labeled TD.

Image 1



Image 2

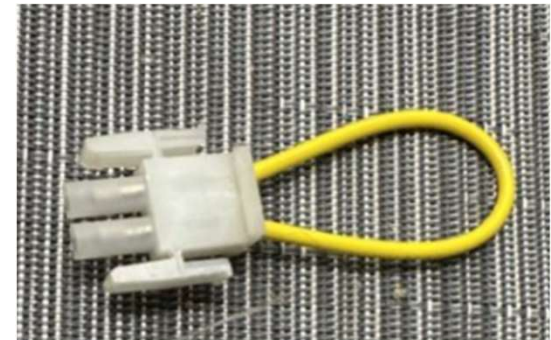

Step 2 – Switch Connection W/O Carefree Switch

1. If the coach is not equipped with the Carefree awning on/off switch, follow the below steps. Otherwise move onto the next page.
2. Leave the jumper from the new harness installed. This makes it so connections to the spades FFT and FFT-1 are not necessary, these can be taped up. See Image 1 red arrows for unneeded spades and blue for jumper installed.
3. Leave the TD connections on the new harness untaped and disconnected, this will be connected later once power is restored.

Image 1

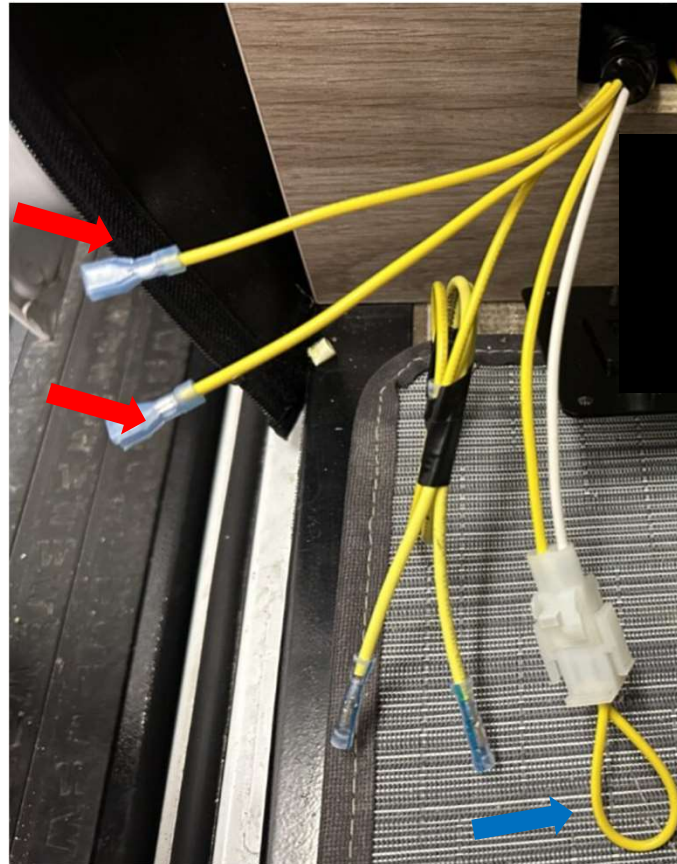

Step 2 – Coach 12v Fuse Panel Connection

1. As needed, unmount the Coach 12v Fuse Panel.
2. Connect the spade connector on NM to an open spade terminal on the back of the Coach 12v Fuse Panel. See Image 1, red arrow.
3. Install a 15A fuse on the front of the Coach 12v Fuse Panel into the matching space and label this fuse "Awning". See Image 2 and 3 red arrows.
4. Attach RY to the ground bar of the Coach 12v Fuse Panel, see Image 4.

Image 1

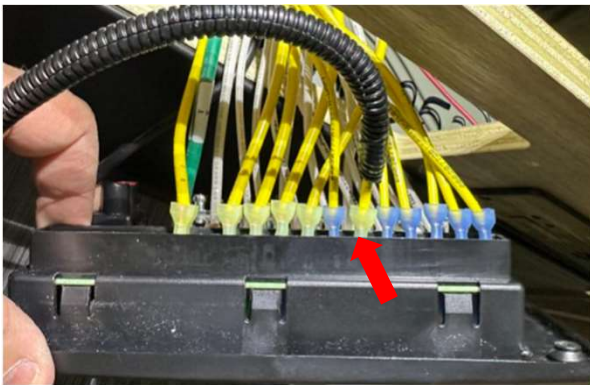

Image 2

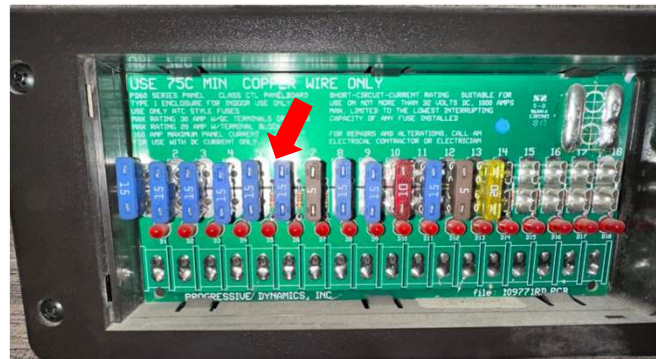
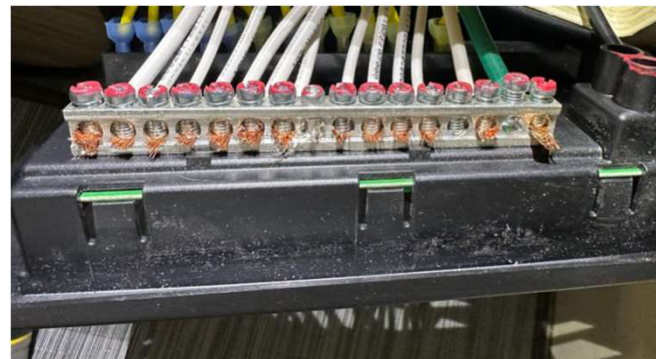

Image 3

1	LIGHTS	10	HEATER
	15 A FUSE MAX	10	A FUSE MAX
2	12V RCP	11	TANK HEATER
	15 A FUSE MAX	30	A FUSE MAX
3	USB CHARGER	12	
	15 A FUSE MAX		A FUSE MAX
4	MONITOR PANEL	13	
	15 A FUSE MAX		A FUSE MAX
5	VENT	14	
	15 A FUSE MAX		A FUSE MAX
6	Awning	15	
	15 A FUSE MAX		A FUSE MAX
7	LP DETECTOR	16	
	5 A FUSE MAX		A FUSE MAX
8	WATER PUMP	17	
	15 A FUSE MAX		A FUSE MAX
9	REFRIG	18	
	15 A FUSE MAX		A FUSE MAX

Image 4



Step 3 – BT-12 Connection

1. Cut the current connection to the red, green, and violet wires of the BT-12 module. Wrap these original circuits with tape, they will no longer be used.
2. Splice the below connections from the new harness to the BT-12:
 - AWP to Red
 - ASY to Green
 - FFT-1 to Violet
3. Check the wiring connections at the BT-12 module and verify that every circuit is properly connected. See Image 1 or the Wiring Diagram –BT-12 page at the back of this packet for proper connections.
4. Check the wiring connections at the BT-12 module and verify that every circuit is properly connected. See the Wiring Diagram – BT-12 page at the back of this packet for proper connections.
5. Use adhesive on the BT-12 to permanently mount it to the chassis rib behind the closeout, see Image 2 Red Arrow. Secure with additional wire ties as needed to create strain relief and ensure drip loop, see Image 2 Yellow Arrow. Be sure to prep surfaces prior to using any adhesive connection.
6. Reinstall the passenger side stepwell cover, drawers, fuse panel, abs trim, and door seal.

Image 1

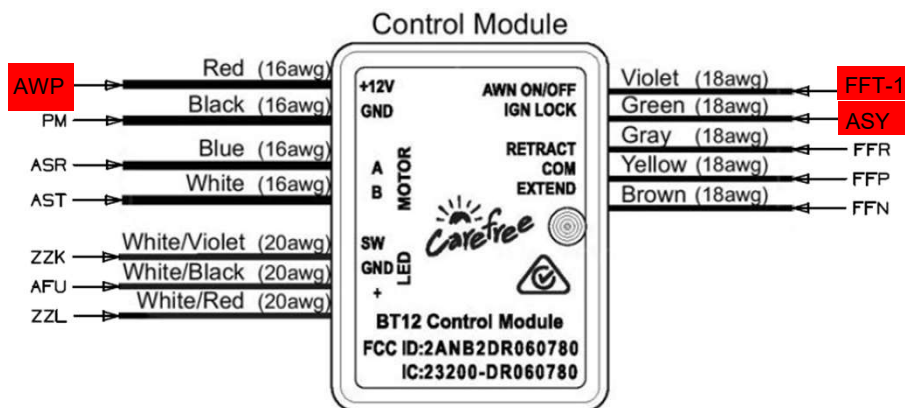
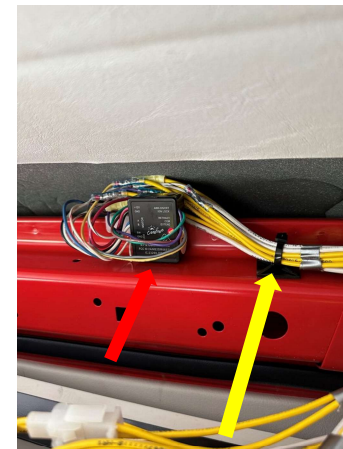

Image 2



Step 4 – Seal Awning Wire Passthrough

1. Go to the coach roof and locate the wiring on the awnings left hand side.
2. Remove electrical tape wrap without damaging wires to gain access to the interior of the convolute tubing, see Image 1.
3. Insert nozzle of cartridge gun into convolute tubing as far into the coach as you can, seal the inside tubing back to 2 inches up from the roof, see Image 2. Ensure sealant oozes out to confirm the convolute is fully filled. Wipe off excess, prep, and retape convolute starting from the roof and wrapping up to the awning creating a shingled effect. See Image 3
4. Using Manus, reseal on top of the existing self-leveling around the base of the convolute and tool to ensure no gaps are present, see Image 4.

Image 1



Image 2

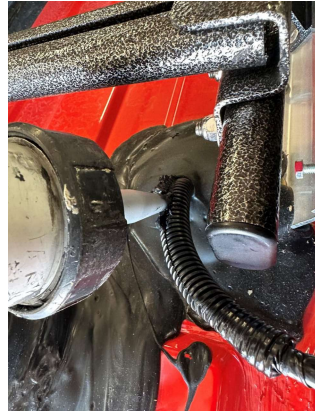

Image 3

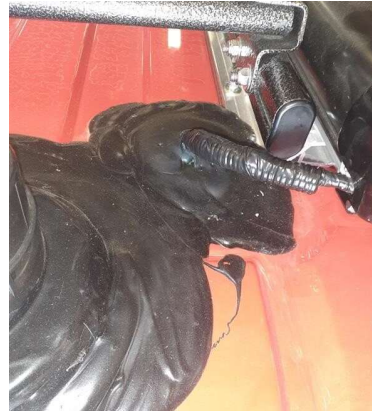

Image 4



Step 5 – Reconnect the 12v power sources.

1. Turn on the 12v house disconnect switch – See Image 1.
2. Reconnect the 12v chassis battery ground. Refer to the Promaster user manual to disconnect the ground cable from the battery.

Image 1



Step 6 – TD Connection

1. In the galley cabinet near the awning switch, locate the circuits labeled TD on the existing harnesses.
2. Note: Some of the existing TD circuits may have been fully disconnected during the recall and will no longer carry chassis power. These circuits can be taped off or removed as they are no longer a useable connection.
3. Using a multimeter, test these circuits to find one that shows 12v power now that chassis power is restored.
4. For units with the Carefree Switch: Splice the new harness to one of the hot TD circuits. See image 1 yellow arrow. The other unused TD circuit connections, if any, can be taped up.
5. For units without the Carefree Switch: Splice the 2 TD connections in line with the hot TD circuit. See image 2.

Image 1



Image 2

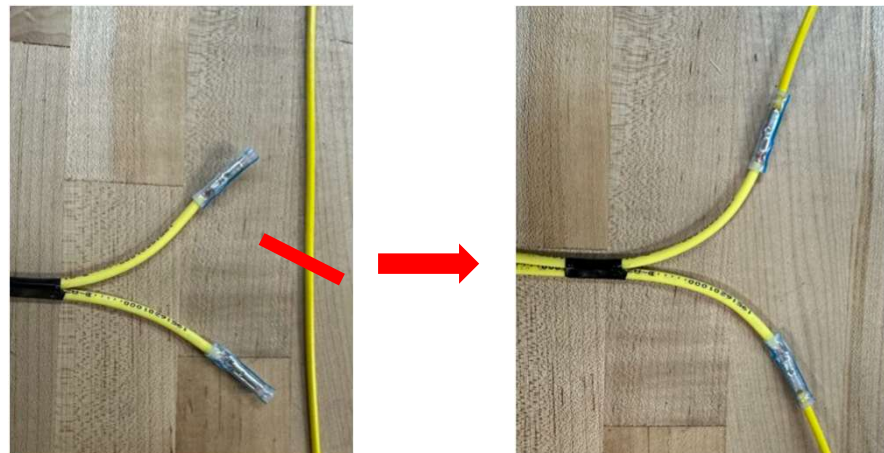

Step 7 – Awning Motor wedge and firmware update

1. Before performing the motor wedge installation, confirm that the awning installed requires a wedge, and that one is not already installed. When inspecting the awning be sure to check both sides for the motor, as depending on build it may be a right-hand or left-hand motor.
 1. Confirm that the awning is an angle gear motor, this style of motor is the one that requires the wedge. See Image 1 for an example of what the angle gear motor looks like with the awning extended. Tubular style motors, where the motor is housed inside the awning fabric roller, do not require a wedge.
 2. If the awning is an angle gear motor, gain access to the backside of the motor by removing the case end cap, see Image 2. Some coaches may require the mounting screws be removed and the awning to be slid back on the mounting extrusion in order to access the cover. When doing this be careful to not pop the awning out of the mounting extrusion as it could fully detach from the coach.
 3. Confirm that a wedge is not installed, Image 3 shows a motor with a wedge already installed.
 4. If your coach does not have the wedge and requires one, move onto the next page and follow the wedge installation.

Image 1



Image 2



Image 3



Step 7 – Awning motor wedge and firmware update(Cont.)

1. Review and complete the following documents, all units with a BT-12 require a firmware update.
 - Carefree Motor Wedge Installation service manual, 056513-002R1(LH) or 056513-001R5(RH) . (For angle gear awnings without a wedge already installed)
 - Carefree Connects Firmware Update service manual, 056513-004r1 (All awning with a BT-12)



Step 8 – System Testing

- See the chart in Image 1 and confirm that all 'With' situations result in the correct actions when the extend and retract commands are operated.
 - Note:** awning will need to be partially extended to confirm auto-retraction, see Image 2.
 - Note:** the relay module will hold the park brake signal from when the park brake is engaged until the engine is started or the module loses power. This is due to the chassis going to sleep and needing to hold the park brake signal.
- With the engine off and the parking brake and 12v coach power on, bring the awning to a partially extended position, see Image 2. Locate the edge of the awning with the wind sensor and shake the awning to simulate high winds. The awning should automatically retract when the sensor reads the awning movement.
- If all the above actions result in their defined outcomes the rework is complete.

Image 2



Image 1

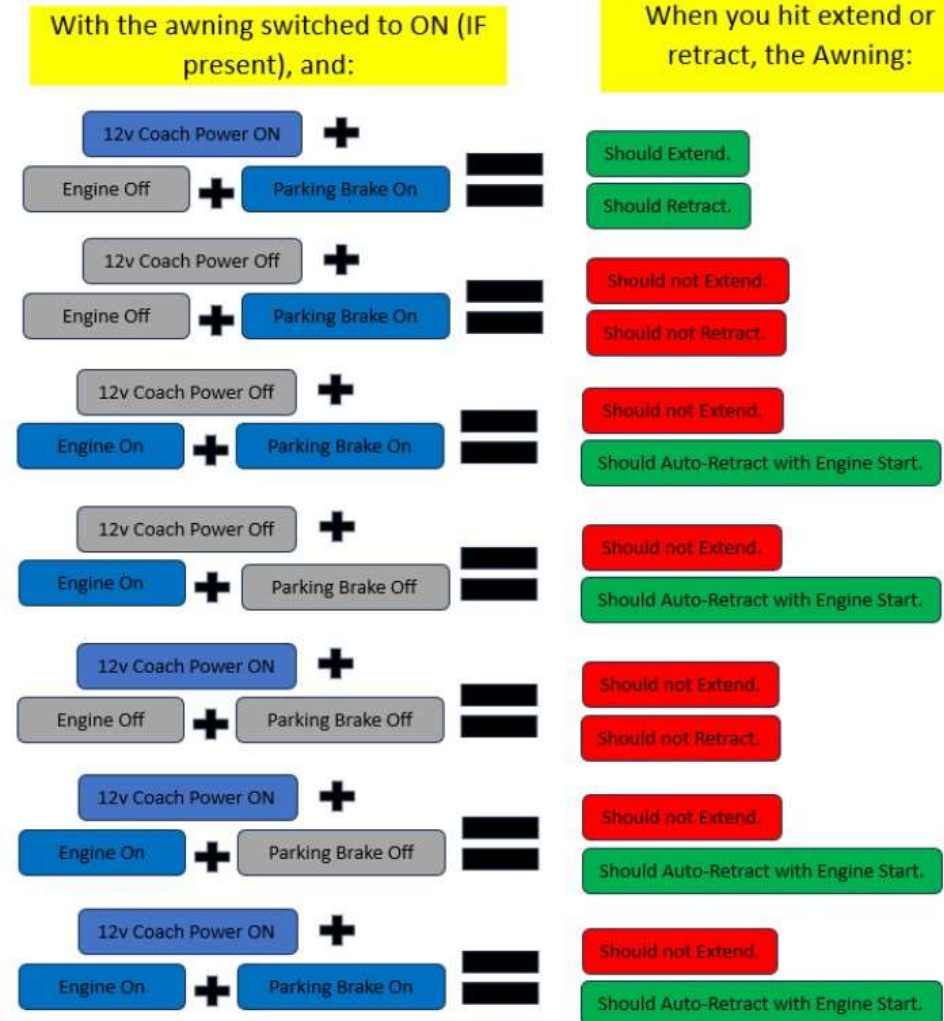

Blank Slide-

Wiring Diagram – Carefree BT-12

BT-12 Wiring Diagram

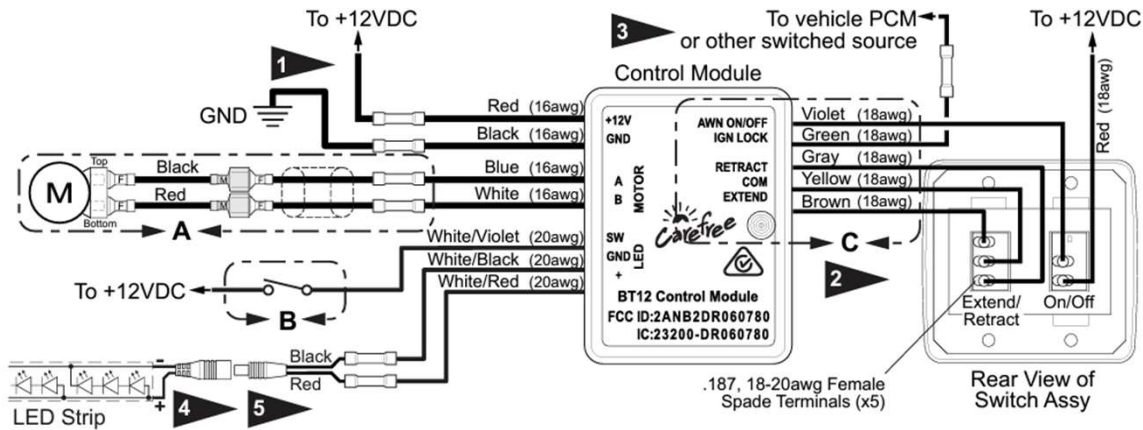

BT-12 to WGO Harness Connections

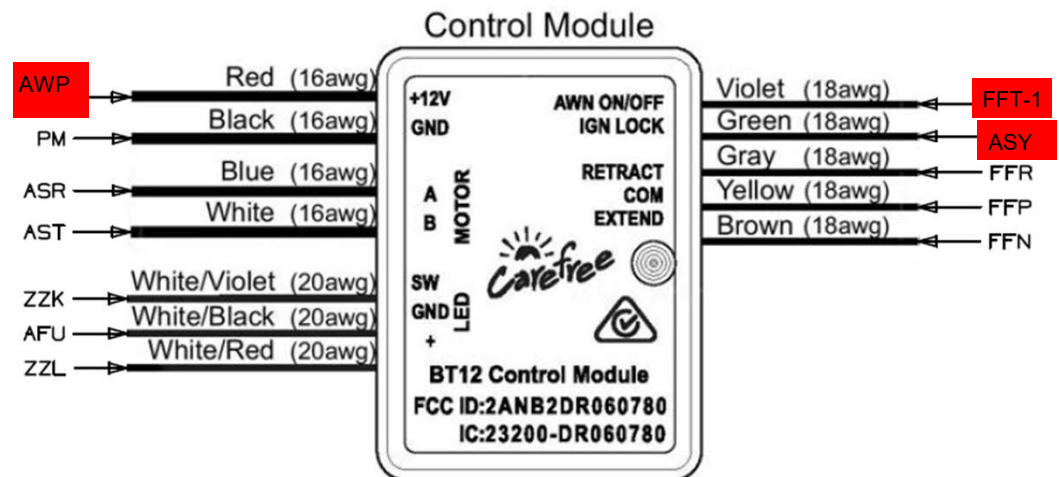

Wiring Diagram – Harness

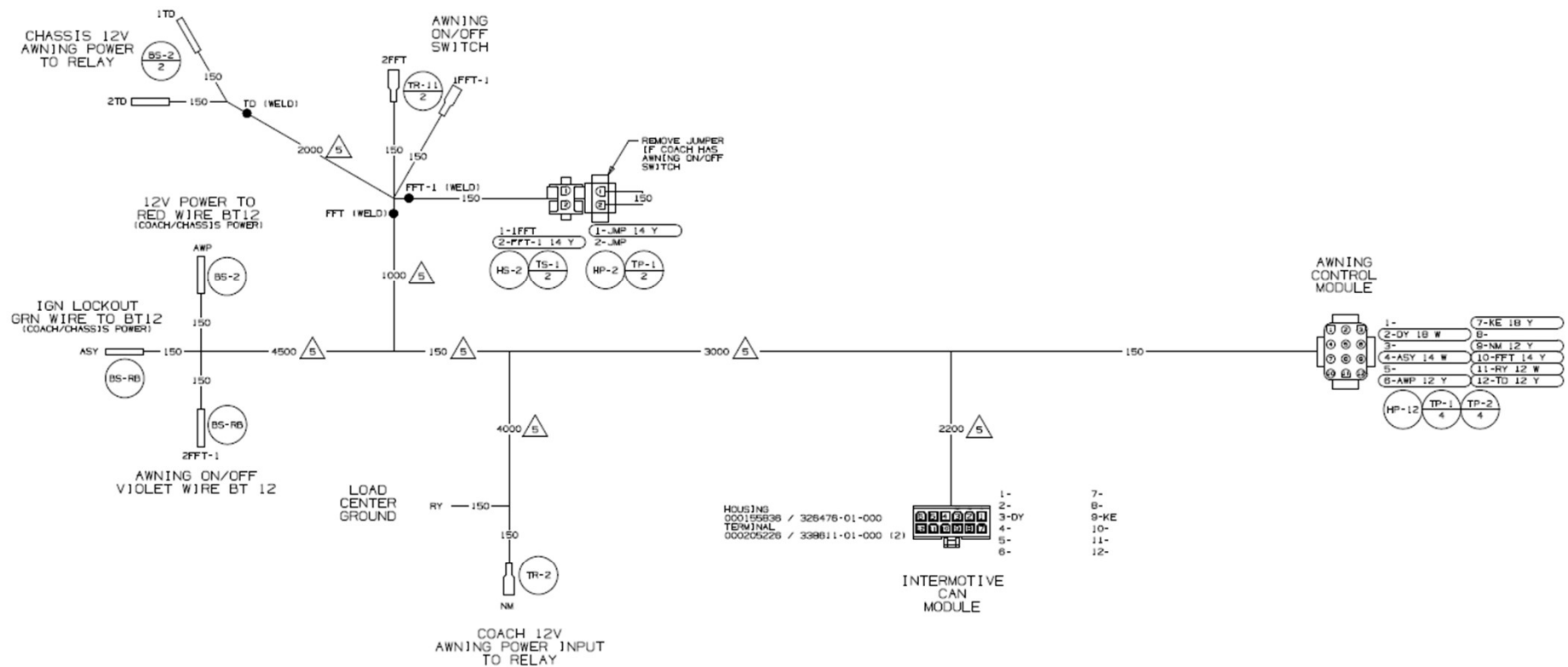

Read the entire instructions carefully before starting the procedure. If you have any questions, please contact Winnebago Industries Technical Service Department by calling 1-866-653-4329 or by email: techservice@wgo.net. This document is confidential and is intended for dealer use only.