

# 2021 or Older Ram Promaster Chassis Travato G/GL Awning Rework:

**Read the entire instructions carefully before starting the procedure. If you have any questions, please contact Winnebago Industries Technical Service Department by calling 1-866-653-4329 or by email: [techservice@wgo.net](mailto:techservice@wgo.net). This document is confidential and is intended for dealer use only.**

2021 and older chassis are identified by having an 'M' or preceding letter as the 10th digit of the VIN, or by having a manual parking brake lever.

## Tools and Supplies required-

1. Screw gun with #2 Philips and T20 Torx bit.
2. Cutting tool.
3. Cartridge gun.
4. Drill
5. 1.25" Unibit or like tool
6. Fish tape
7. Plastic trim tools
8. Wire stripper/crimper
9. Multi Tester
10. Adhesive surface prep
11. Manus Sealant – 185987-03-02A or equivalent
12. Electrical Tape
13. Metal primer – not shown



# 2021 or Older Ram Promaster Chassis Travato G/GL Awning Rework:

## Parts required:

**RC7911-24-776 Gen 1 G/GL**

**RC7919-24-776 Gen 2 G/GL**

1. 1.25" Grommet – 114208-07-000 (3)
2. Large zip ties - 008343-04-000(25)
3. Adhesive zip tie mounts - 357004-01-000 (2)
4. Awning Control Module (Gen 2) - 358901-01-000 (1)
5. Wire Asm - Awning (Gen 1) -358895-01-000, (Gen 2) - 358883-01-000 (1)
6. 15A Fuse – 062901-05-000 (1)
7. P clamp - 083610-01-000 (3).
8. Small zip ties - 008343-03-000(10)
9. Black Self-tapping screw – 000G39-10-12T (3)
10. Silver Self-tapping screw – 000G39-08-12B (4)
11. Double Sided Tape – 076322-22-000 (4")
12. Ring Terminal - 326278-01-000 (1)
13. Screws M4 X 20 – 339810-01-703 (2)
14. Screws #8 x 1", T20 – 339810-01-704 (5)
15. Carefree LH Motor Wedge – 339810-01-709 (1)
16. Butt Splice (Gen 2) – 326335-01-000 (1)



# Step 1 – Pre-Rework Prep

1. Disconnect the shore power cord from the coach – See Image 1.
2. Turn off the house disconnect switch – See Image 2.
3. Disconnect the 12v chassis battery ground. Refer to the Promaster user manual to disconnect the ground cable from the battery.
4. NOTE: If the chassis battery ground is not disconnected before performing the rework, chassis faults may occur that will require a Promaster service center. This cost is not covered under this recall.

Image 1



Image 2



# Step 2 – Installing New Harness

1. Locate and remove the passenger side stepwell covers using a screw gun with Philips bit, see Image 1.
2. Using the Unibit, drill a 1.25" hole going through the chassis as shown, see Image 2 red arrow. The hole should be at most 1" away from the vertical walls. Prime the bare metal around the cut hole to prevent rust.
3. Put a split into a 1.25" grommet, install it on the harness, and then into the floor from above.

Image 1



Image 2

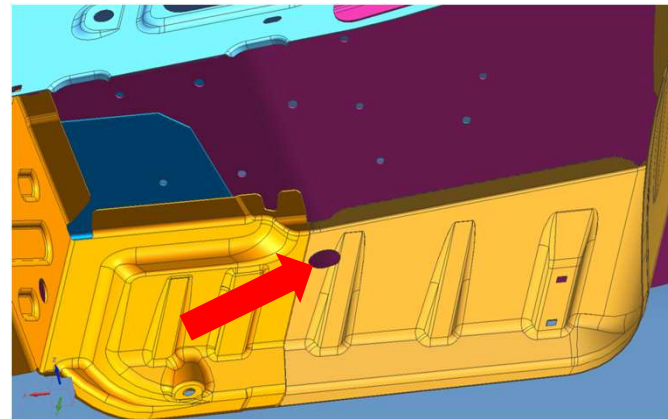

# Step 2 – Installing New Harness – Gen 1

1. If your coach is Gen 1 (Winnebago model years 2016-2019), follow the instructions below. Otherwise continue to next page (5).
2. Mount the relay of the new harness using self-tapping screws on the vertical wall of the stepwell closest to the seat, See Image 1.
3. Follow Step 2A – Installing Harness Driver Side
4. Any excess wiring on the new harness can be pulled through the 1.25" hole.
5. Reinstall the Passenger side stepwell covers.
6. Follow Step 2C – Harness Install Under Coach
7. Follow Step 2H – Route to Roof (awning connection circuits FFT and NM)
8. Continue to Step 3.

Image 1





# Step 2 – Installing New Harness – Gen 2

1. If your coach is Gen 2(Winnebago model years 2020-2021), follow the instructions below. Otherwise refer to previous page (4).
2. Mount the new Awning Control Module using self-tapping screws on the vertical wall of the stepwell closest to the seat, See Image 1. Creating a pilot hole may assist with the installation and avoid damage to the relay board.
3. Connect the 12-pin plug on the new harness to the Awning Control Module.
4. IMPORTANT: The switch on the Awning Control Module controls needs to be set to GROUND– See Image 4.
  - o Setting the switch to GROUND will auto retract the awning when the engine is started.
  - o 12VDC would disable the auto retract function.
5. Follow Step 2A – Installing Harness Driver Side.
6. Follow Step 2B – Harness Install Passenger B Pillar.
7. Follow Step 2C – Harness Install Under Coach.
8. Follow Step 2D – Switch Connection W/ Carefree Switch IF the awning switch looks like Image 2.
9. Follow Step 2E – Switch Connection W/O Carefree Switch IF the awning switch looks like Image 3.
10. Follow Step 2F – Coach 12v Fuse Panel Connection.
11. Follow Step 2G – Installing Harness with Recall 168.
12. Follow Step 2H – Route to Roof (awning connection circuits AWP, ASY, and FFT-1)
13. Continue to Step 3.

Image 1

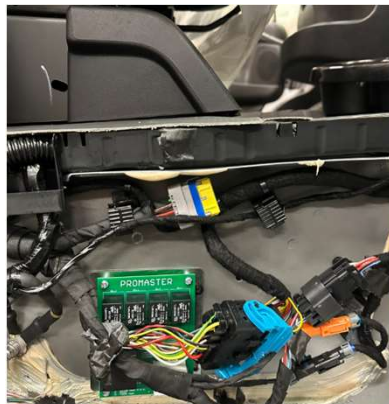

Image 2



Image 3



Image 4



# Step 2A – Installing Harness Driver Side

1. Route the three manual park brake DY circuits from the new harness up under the passenger side wheel well plastic trim and flooring, and behind the passenger kick cover. See Image 1 and 2, yellow arrows.
2. Pop out the center cup holder and screw covers from the center console plastic enclosure. It is held in with clips.
3. Using a screw gun and trim tools, remove the 4 mounting screws and pop the clips to detach the center console plastic enclosure from the chassis.
4. Route behind the center console to reach the driver side, follow and secure to the existing harnesses behind the center console. See Image 3 for entry point.
5. Locate and remove the driver side stepwell covers using a screw gun with Philips bit.
6. Route the harness below the steering column, following the existing harnesses. Then route the harness beneath the driver side stepwell covers. See Image 4, yellow arrows for wire path.

Image 1



Image 2



Image 3

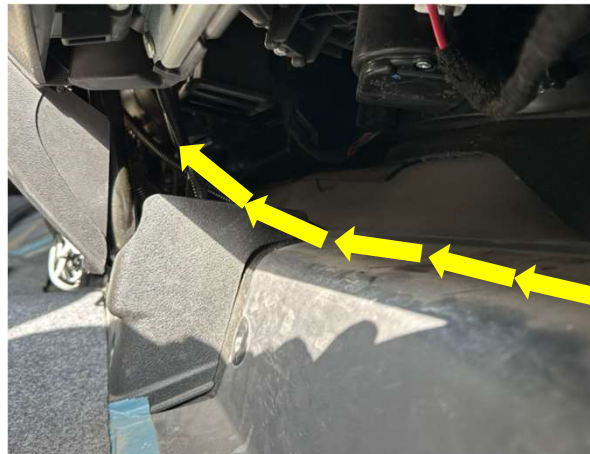

Image 4



# Step 2A – Installing Harness Driver Side (Cont.)

1. Route the harness below the steering column, following the existing harnesses. Then route the harness beneath the driver side stepwell covers. See Image 1, yellow arrows for wire path.
2. Remove the parking brake plastic shroud, it is held on with one screw. See Image 2 red arrow.
3. Remove the parking brake switch from the parking brake bracket, See Image 3 and 4. It is secured with one screw.
4. Connect the female spade DY from the new harness in place of the existing connection to the parking brake spade terminal. See Image 5 red arrow.
5. **Note:** some coaches will already have Winnebago Wiring going to the park brake:
  - a) If your coach does not have this wiring, cut and discard the terminal on the chassis harness. Splice the butt spliced DY from the new harness to the chassis harness that was just cut, See Image 5 green arrow.
  - b) If your coach does have this wiring, follow the steps on the next page.
6. Secure the harness so that it is immobilized up to the 1.25" hole in the passenger stepwell. Ensure the harness is not visible to the end user.
7. Reinstall the driver side stepwell covers and center console.

Image 1



Image 2



Image 3



Image 4



Image 5

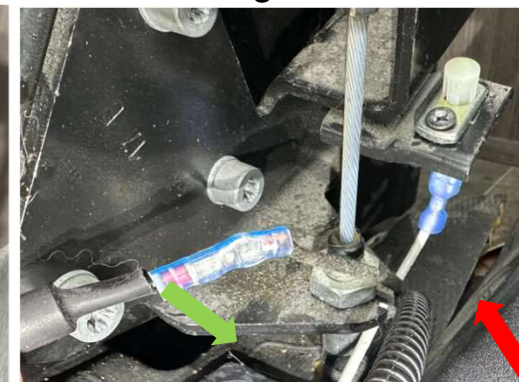



# 2A - Installing Harness Driver Side (Cont.)

1. Some coaches will already have a Winnebago harness going to the chassis park brake, if this is the case follow the steps below.
2. Locate DY on the existing harness that passes through the driver side stepwell.
3. Cut the existing harness to separate the diodes and park brake connections from the rest of the harness.
4. Terminate the DY that runs up into the dash with the supplied ring terminal, See Image 1.
5. Connect the ring terminal to the chassis ground stud and torque to 8NM(5.9 Ft Lbs.), See Image 2.
6. Connect the butt splice DY on the new harness to the chassis park brake harness in place of the existing harness's DY. See Image 3, Red arrow.
7. Return to the previous page and ensure step 2A is complete before moving forward.

Image 1



**WINNEBAGO**  
INDUSTRIES

Image 2



Image 3



# Step 2B – Installing Harness Passenger B Pillar

1. Unscrew the forward 2 screws on the passenger side B pillar cover and partially pull away for access. See Image 1.
2. Route the 15 pin plugs on the new harness from the Passenger stepwell into the B pillar.
3. Replace the male 15 pin housing already connected to the bodybuilder plug with the new harness' 15-pin male connector. See Image 2.
4. Connect the original harness' Male connector the new harness' 15-pin female connector. See Image 3.
5. Tuck the harness below the floor as it travels from the stepwell to the B pillar. See Image 4 yellow line for path.
6. **Note:** Your coach may not have the adjoining ZZJ circuit to match the new harness. Additionally, the color of the wires in mating circuits at these connectors may not match. This is expected and will not affect the functionality of the coach.

Image 1



Image 2



Image 3

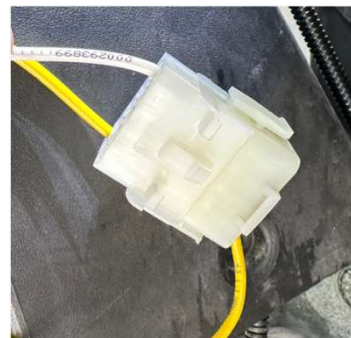

Image 4



# Step 2B – Installing Harness Passenger B Pillar (Cont.)

1. Locate the Chime Relay on the existing harness. This should be located in the passenger side B pillar and will have the connections shown in Image 1.
  - There are two JJX circuits going into this relay.
2. Locate the JJX going to pin 85. Cut the wire leaving some of it on the relay side to splice to.
3. Connect the butt spliced FFT from the new harness to the wire going into pin 85 of the relay.
  - FFT replaces JJX on the shade relay to allow the park brake to disable the shade chime, with the engine running.
  - Note: there are 2 butt spliced FFT connections on the new harness. Ensure the one you connect to is near the relay, not the one in a branch with NM.
4. Tape up the cut JJX from the existing harness, it will not be used.

Image 1

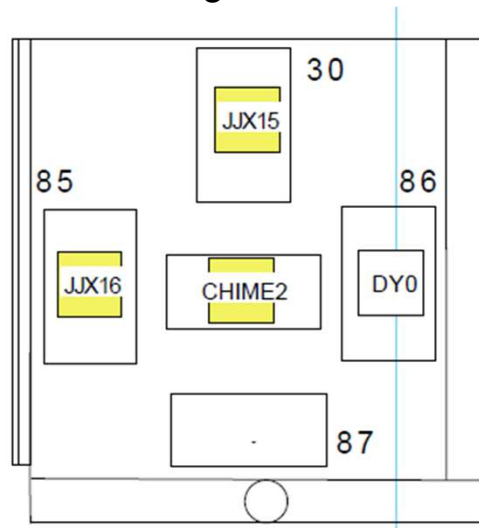

# Step 2C – Installing Harness Under Coach Gen 1 2016

1. Follow these instructions for Gen 1 2016 coaches, otherwise continue to next page.
2. On the coach interior, gain access to the galley cabinet interior by removing the drawers.
3. Drill a 1.25" hole through the chassis into the galley cabinet. The best location for this hole may vary by build, locate an open area within the footprint of the galley cabinet to drill through. When identifying a location drill a pilot hole from inside the cabinet down and then cut the 1.25" hole up to confirm there is no obstacles or damage to existing parts. A typical location is shown in Image 2, red arrow. Prime the bare metal around the cut hole to prevent rust.
4. Route the new harness from the passenger stepwell back through the LP manifold mounting bracket. Bring the harness up into the Galley cabinet 1.25" hole. See Image 5, red arrows. Cut a split into a 1.25" grommet, install it on the harness, and then into the floor from above.
5. Secure the new harness up to the existing Winnebago harnesses or chassis mounting holes using zip ties and to the chassis rib using P clamps. See Images 5, yellow arrows. The new harness should not be allowed to sag below the existing harnesses. The 1.25" holes in the chassis can be filled with Manus to prevent water intrusion.

Image 2

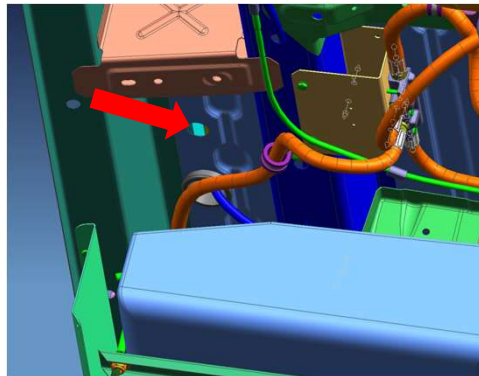
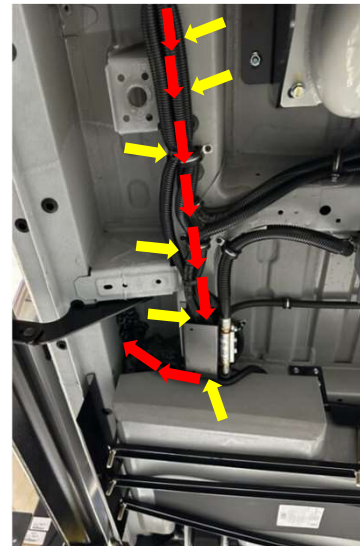

Image 5





# Step 2C – Installing Harness Under Coach Gen 1 2017-2019

1. Follow these instructions for Gen 1 2017-2019 coaches, otherwise continue to next page.
2. Gain access to the area behind the fuse panel in the bed cabinet. This can be done by removing the drawer above the fuse panel and unmounting the fuse panel itself. See Image 1.
3. Below the coach, drill a 1.25" hole up through the chassis into the bed cabinet, See Image 3 red arrow for a typical location. The best location for this hole may vary by build, locate an open area behind the breaker and fuse panels in the bed cabinet to drill through. When identifying a location drill a pilot hole from inside the cabinet down and then cut the 1.25" hole up to confirm there is no obstacles or damage to existing parts. Prime the bare metal around the cut hole to prevent rust.
4. Route the new harness from the passenger stepwell back through the LP manifold mounting bracket. See Image 5, red arrows.
5. Route the new harness through the grey tank mounting brackets, over the rearward battery, and into the new bed cabinet 1.25" hole. See Image 4 and 6, red arrows. Cut a split into a 1.25" grommet, install it on the harness, and then into the floor from above.
6. Secure the new harness up to the existing Winnebago harnesses or chassis mounting holes using zip ties and to the chassis rib using P clamps. See Images 4, 5 and 6, yellow arrows. The new harness should not be allowed to sag below the existing harnesses. The 1.25" holes in the chassis can be filled with Manus to prevent water intrusion.

Image 5



Image 1



Image 3



Image 4



Image 6



# Step 2C – Installing Harness Under Coach Gen 2

1. Follow these instructions for Gen 2 coaches, otherwise continue to next page.
2. On the coach interior, gain access to the galley cabinet interior by removing the drawers.
3. Gain access to the area behind the fuse panel in the bed cabinet. This can be done by removing the drawer above the fuse panel and unmounting the fuse panel itself. See Image 1.
4. Drill a 1.25" hole through the chassis into the galley cabinet. The best location for this hole may vary by build, locate an open area within the footprint of the galley cabinet to drill through. When identifying a location drill a pilot hole from inside the cabinet down and then cut the 1.25" hole up to confirm there is no obstacles or damage to existing parts. A typical location is shown in Image 2, red arrow. Prime the bare metal around the cut hole to prevent rust.
5. Below the coach, drill a 1.25" hole up through the chassis into the bed cabinet, See Image 3 red arrow for a typical location. The best location for this hole may vary by build, locate an open area behind the breaker and fuse panels in the bed cabinet to drill through. When identifying a location drill a pilot hole from inside the cabinet down and then cut the 1.25" hole up to confirm there is no obstacles or damage to existing parts Prime the bare metal around the cut hole to prevent rust.
6. Route the new harness from the passenger stepwell back through the LP manifold mounting bracket. Bring the harness up into the Galley cabinet 1.25" hole. See Image 5, red arrows. Cut a split into a 1.25" grommet, install it on the harness, and then into the floor from above.
7. Route the new harness branch with NM through the grey tank mounting brackets, over the rearward battery, and into the new bed cabinet 1.25" hole. See Image 4 and 6, red arrows. Cut a split into a 1.25" grommet, install it on the harness, and then into the floor from above.
8. Secure the new harness up to the existing Winnebago harnesses or chassis mounting holes using zip ties and to the chassis rib using P clamps. See Images 4, 5 and 6, yellow arrows. The new harness should not be allowed to sag below the existing harnesses. The 1.25" holes in the chassis can be filled with Manus to prevent water intrusion.

Image 5

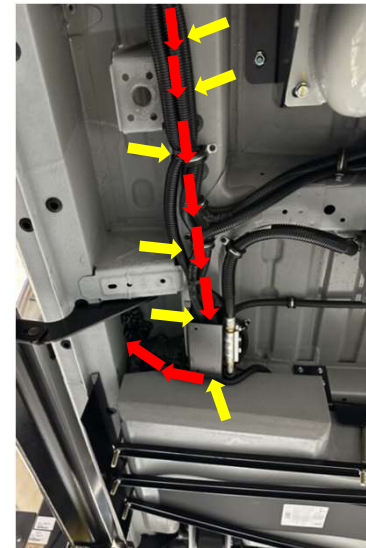

Image 1



Image 2

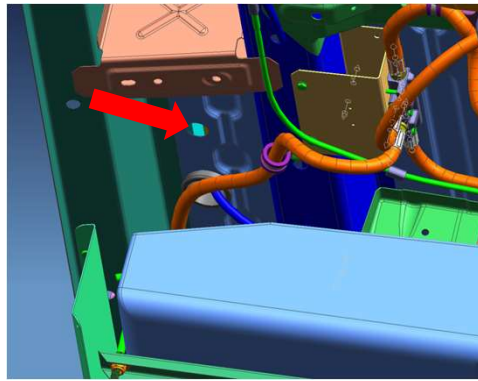

Image 3



Image 4



Image 6

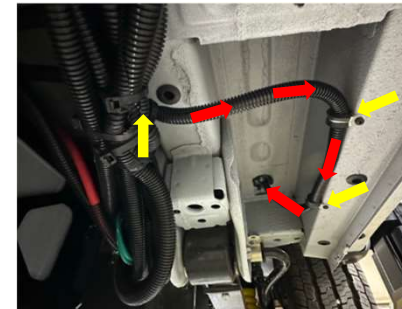

# Step 2D – Switch Connection W/ Carefree Switch

1. If the coach is equipped with the Carefree awning on/off switch, follow the below steps.
2. Connect the branch FFT and FFT-1 spade connector from the new harness to the awning on/off switch in place of the current connections. See Image 1 red arrows .
3. Remove the jumper from the new harness and discard. See Image 2.
4. Leave one of the TD connections on the new harness un-taped and disconnected, this will be connected later once power is restored.
5. The remaining TD wire connection on the new harness will not be used, it can be taped up along with all other connections on the original harnesses in this area that are not labeled TD.

Image 1



Image 2

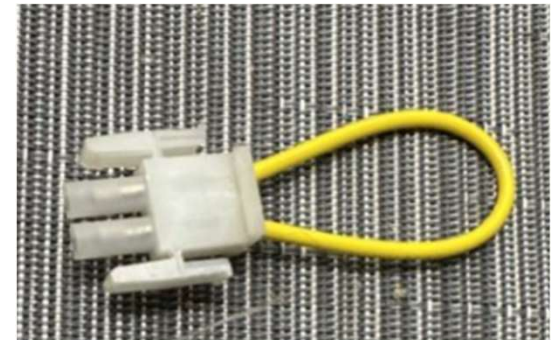



# Step 2E – Switch Connection W/O Carefree Switch

1. If the coach is not equipped with the Carefree awning on/off switch, follow the below steps.
2. Leave the jumper from the new harness installed. This makes connections to the spades FFT and FFT-1 not necessary, these can be taped up. See Image 1 red arrows for unneeded spades and blue for jumper installed.
3. Leave the TD connections on the new harness un-taped and disconnected, this will be connected later once power is restored.

Image 1

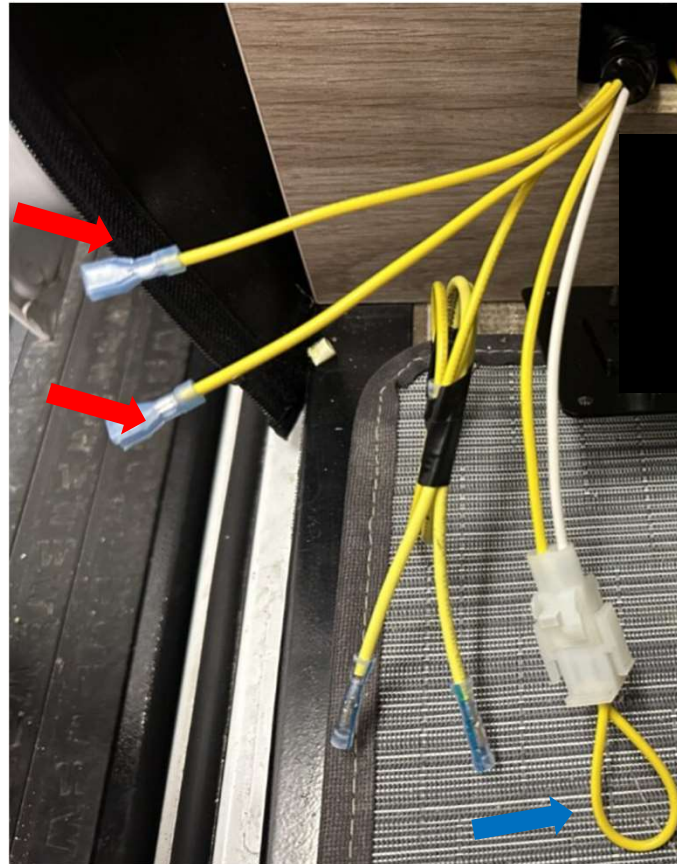



# Step 2F – Coach 12v Fuse Panel Connection

1. As needed, unmount the Coach 12v Fuse Panel.
2. Connect the spade connector on NM to an open spade terminal on the back of the Coach 12v Fuse Panel. See Image 1, red arrow.
3. Install a 15A fuse on the front of the Coach 12v Fuse Panel into the matching space and label this fuse "Awning". See Image 2 and 3 red arrows.
4. Attach RY to the ground bar of the Coach 12v Fuse Panel, See Image 4.

Image 1

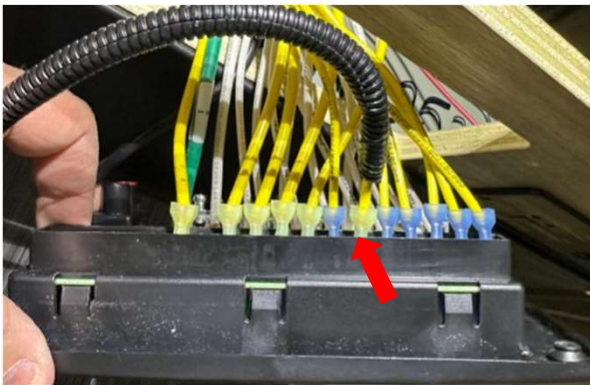

Image 2



Image 4



Image 3

1	LIGHTS	10	HEATER
	15 A FUSE MAX	10	A FUSE MAX
2	12V RCP	11	TANK HEATER
	15 A FUSE MAX	30	A FUSE MAX
3	USB CHARGER	12	
	15 A FUSE MAX		A FUSE MAX
4	MONITOR PANEL	13	
	15 A FUSE MAX		A FUSE MAX
5	VENT	14	
	15 A FUSE MAX		A FUSE MAX
6	Awning	15	
	15 A FUSE MAX		A FUSE MAX
7	LP DETECTOR	16	
	5 A FUSE MAX		A FUSE MAX
8	WATER PUMP	17	
	15 A FUSE MAX		A FUSE MAX
9	REFRIG	18	
	15 A FUSE MAX		A FUSE MAX

# Step 2G – Installing Harness with Recall 168

1. Some coaches may have recall 168 previously completed . This can be identified visually through the addition of the harness in Image 1 installed between the BT-12 and the awning switch.
  - The Part Number printed on the wires should be 000270094
2. If this harness is present, cut all connections and remove the harness.
  - Note: Because the harness is running up to the BT-12, it may be useful to tape the new harness to a section of the recall 168 harness and pull it through.
3. The continuity of the TD circuit on the original harness should be restored. This can be done using 1TD and 2TD on the New Harness.
  - If this is done, any following references to connecting TD can be disregarded.
4. Follow the proceeding pages for the other new connections.

Image 1

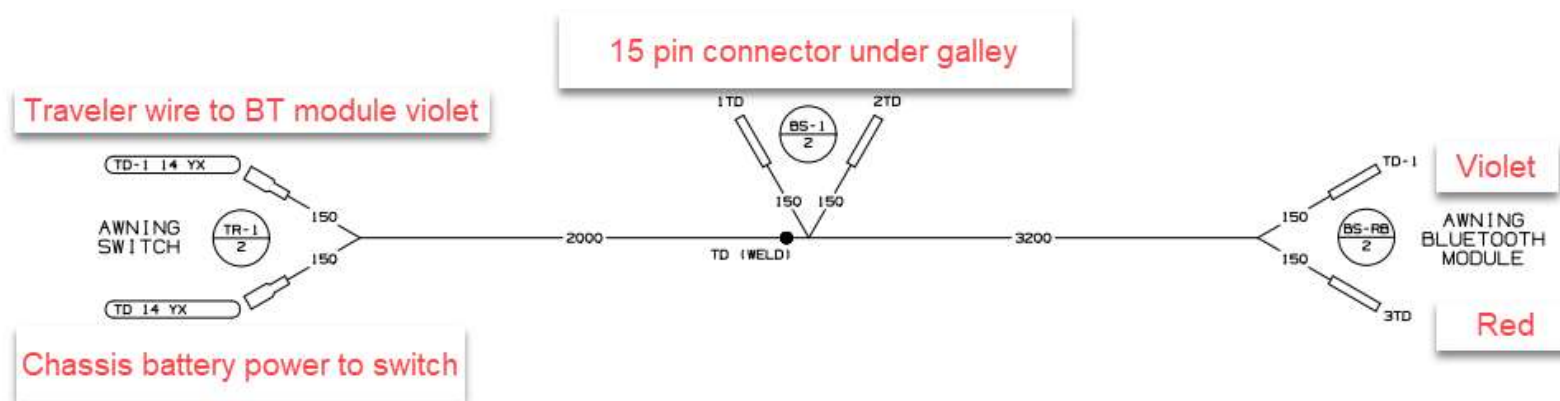

# Step 2H – Route to Roof

1. Partially unmount the plastic closeout panel above the sliding door. The closeout panel is secured to the roof, sidewall rib, and screen door. Only remove screws as needed to pull away panel, and gain access to the necessary connections. See Image 1 for screw locations, keep track of which type of screw goes into which hat retainer.
2. Take the awning connection circuits of the new harness and route it behind the cabinet, up through the plastic trim at the rear of the sliding door, and up to the BT-12. There is a recessed path that allows the wire to pass through without interfering with the abs panel fitment, See Image 2 and 4 yellow arrows for wire path. Use trim tools as needed to pry the panels away and fish tape to bring the circuits up, See Image 3. The sliding door seal can be removed for easier access.

Image 1



Image 2



Image 3



Image 4



# Step 3A – No BT-12 – Gen 1

1. This is relevant for 2016 Winnebago model year Travato's . This can be identified by the connections made to the awning switch in Image 1. If your coach does not have these circuits going to the awning switch proceed to the next page.
2. Locate one of the NM's that goes into the awning switch, follow this back 300mm where NM splits off.
3. Cut circuit NM before it splits off to go to the switch.
4. Follow Image 2 for connecting FFT and NM from the new harness to the existing NM circuit that was just cut. FFT will splice on going towards the switch, and NM back towards the rest of the existing harness.
5. Reinstall the drawers, plastic panels, and the passenger stepwell cover.

Image 1

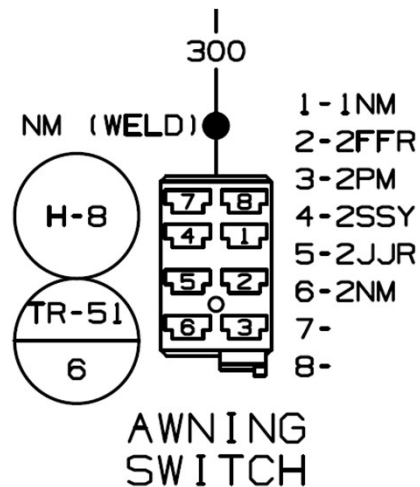
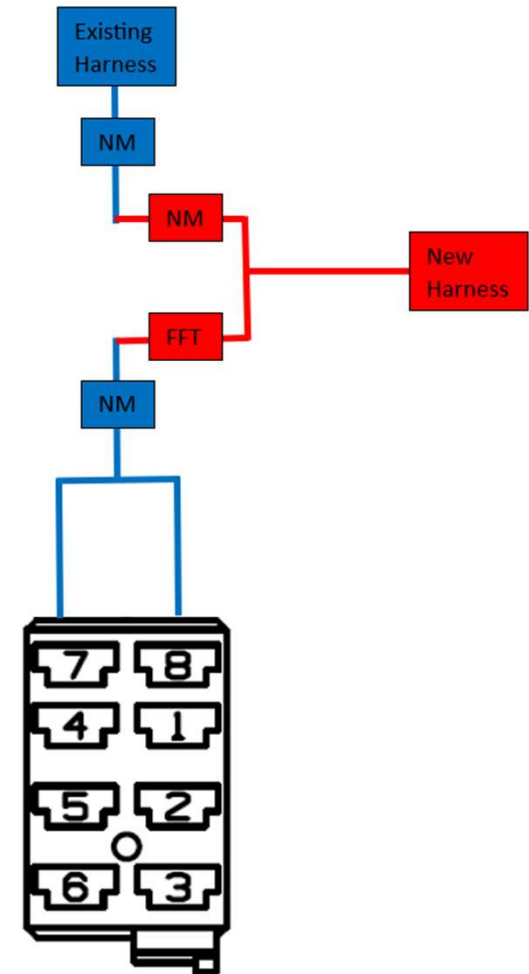

Image 2





# Step 3A – No BT-12 – Gen 1

1. This is relevant for 2017-2019 Winnebago model year Travato's. This can be identified by the connections made to the awning switch in Image 1. If your coach does not have these circuits going to the awning switch proceed to the next page.
2. At the back of the fuse panel in the Bed cabinet, locate NM which has a spade connector attaching it to the fuse panel.
3. Cut NM on the original harness leaving some of it on the spade terminal side to splice to.
4. Follow Image 2 for connecting FFT and NM from the new harness to the existing NM circuit that was just cut. FFT will splice going toward the existing harness, and NM will splice onto the wire going to the fuse panel.

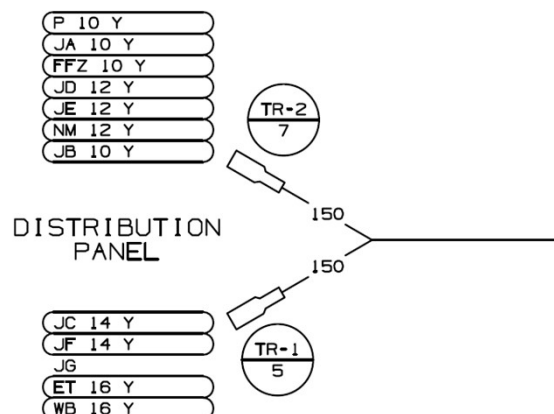
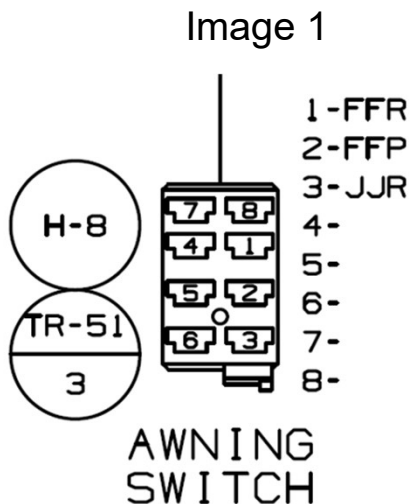
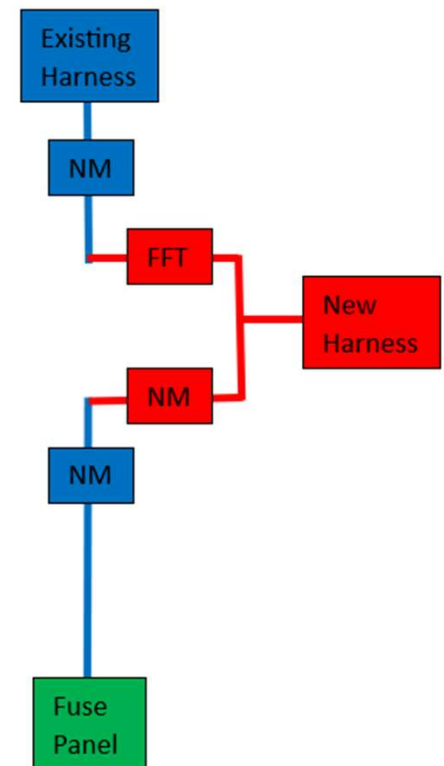
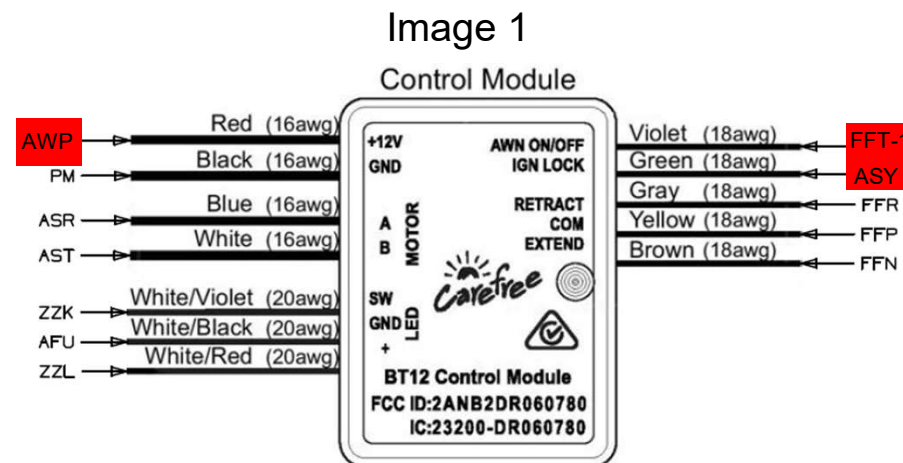

Image 2



# Step 3B – BT-12 Connection – Gen 2

1. Units built as Winnebago's 2020 model year or later should have a BT-12 installed.
2. Locate the BT-12, it is either located behind the awning switches or up behind the abs closeout above the sliding door.
3. Cut the current connection to the red, green, and violet wires of the BT-12 module. Wrap these original circuits on the existing harness with tape, they will no longer be used.
4. Splice the below connections from the new harness to the BT-12:
  - o AWP to Red
  - o ASY to Green
  - o FFT-1 to Violet
5. Check the wiring connections at the BT-12 module and verify that every circuit is properly connected. See Image 1 or the Wiring Diagram –BT-12 page at the back of this packet for proper connections.
6. Use the adhesive on the BT-12 to permanently mount it to a vertical surface. Ensure the wires come down creating a drip loop. Secure wire with additional wire ties as needed to create strain relief and ensure drip loop.
7. Reinstall the drawers, plastic panels, fuse panel, and the passenger stepwell cover.



# Step 4 – Seal Awning Wire Passthrough

1. Go to the coach roof and locate the wiring on the awnings left hand side.
2. Remove electrical tape wrap without damaging wires to gain access to the interior of the convolute tubing, See Image 1.
3. Insert nozzle of cartridge gun into convolute tubing as far into the coach as you can, seal the inside tubing back to 2 inches up from the roof, See Image 2. Ensure sealant oozes out to confirm the convolute is fully filled. Wipe off excess, prep, and retape convolute starting from the roof and wrapping up to the awning creating a shingled effect. See Image 3
4. Using Manus, reseal on top of the existing self-leveling around the base of the convolute and tool to ensure no gaps are present, See Image 4.

Image 1



Image 2

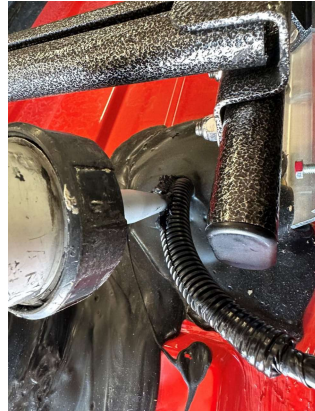

Image 3

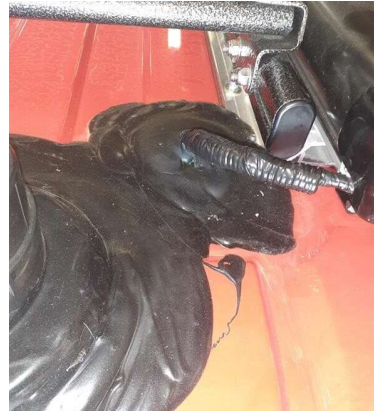

Image 4



# Step 5 – Reconnect the 12v power sources.

1. Turn on the 12v house disconnect switch – See Image 1.
2. Reconnect the 12v chassis battery ground. Refer to the Promaster user manual to disconnect the ground cable from the battery.

Image 1





# Step 6 – TD Connection - Gen 2

1. If your coach is Gen 2(Winnebago model years 2020-2021), follow the instructions below. Otherwise continue to step 7.
2. Note: Some of the existing TD circuits, either on the original harness may have been fully disconnected during the recall and will no longer carry chassis power. These circuits can be taped off or removed as they are no longer a useable connection.
3. For units with the Carefree switch:
  - a) In the galley cabinet near the awning switch, locate the circuits labeled TD on the existing harnesses.
  - b) Using a multimeter, test these circuits to find one that shows 12v power now that chassis power is restored.
  - c) Splice the new harness to one of the hot TD circuits. See Image 1 yellow arrow. The other unused TD circuit connections, if any, can be taped up.
4. For units without the Carefree Switch:
  - a) In the galley cabinet splice the 2 TD connections of the new harness in line with the hot TD circuit that can be found in the existing wire harness. See Image 2.

Image 1



Image 2

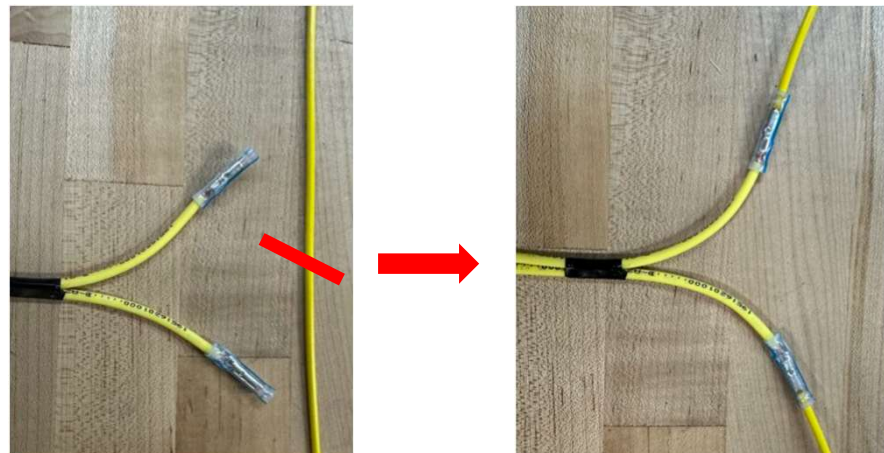

# Step 7 – Awning Motor wedge and firmware update

1. Before performing the motor wedge installation, confirm that the awning installed requires a wedge, and that one is not already installed. When inspecting the awning be sure to check both sides for the motor, as depending on build it may be a right-hand or left-hand motor.
  1. Confirm that the awning is an angle gear motor, this style of motor is the one that requires the wedge. See Image 1 for an example of what the angle gear motor looks like with the awning extended. Tubular style motors, where the motor is housed inside the awning fabric roller, do not require a wedge.
  2. If the awning is an angle gear motor, gain access to the backside of the motor by removing the case end cap, see Image 2. Some coaches may require the mounting screws be removed and the awning to be slid back on the mounting extrusion in order to access the cover. When doing this be careful to not pop the awning out of the mounting extrusion as it could fully detach from the coach.
  3. Confirm that a wedge is not installed, Image 3 shows a motor with a wedge already installed.
  4. If your coach does not have the wedge and requires one, move onto the next page and follow the wedge installation.

Image 1



Image 2



Image 3



# Step 7 – Awning motor wedge and firmware update(Cont.)

1. Review and complete the following documents, all units with a BT-12 require a firmware update.
  - Carefree Motor Wedge Installation service manual, 056513-002R1(LH) or 056513-001R5(RH) . (For angle gear awnings without a wedge already installed)
  - Carefree Connects Firmware Update service manual, 056513-004r1 (All awning with a BT-12)





# Step 8 – System Testing, GEN 1

1. This page is for Gen 1 coaches only, move onto next page for Gen 2.
2. See the chart in Image 1 and confirm that all 'With' situations result in the correct actions when the extend and retract commands are operated.
  - o **Note:** awning will need to be partially extended to confirm retraction, See Image 2.
3. If all the above actions result in their defined outcomes the rework is complete.



Image 2

Image 1

With the awning switched to ON (IF present), and:		When you hit extend or retract, the Awning:
12v Coach Power ON	+	Should Extend.
Engine Off	+	Should Retract.
12v Coach Power Off	+	Should not Extend.
Engine Off	+	Should not Retract.
12v Coach Power Off	+	Should not Extend.
Engine On	+	Should not Retract.
12v Coach Power Off	+	Should not Extend.
Engine On	+	Should not Retract.
12v Coach Power ON	+	Should not Extend.
Engine Off	+	Should not Retract.
12v Coach Power ON	+	Should not Extend.
Engine On	+	Should not Retract.
12v Coach Power ON	+	Should not Extend.
Engine On	+	Should Retract.



# Step 8 – System Testing, GEN 2

1. This page is for Gen 2 coaches only.
2. See the chart in Image 1 and confirm that all 'With' situations result in the correct actions when the extend and retract commands are operated.
  - o **Note:** awning will need to be partially extended to confirm auto-retraction, See Image 2.
  - o **Note:** the relay module will hold the park brake signal from when the park brake is engaged until the engine is started or the module loses power. This is due to the chassis going to sleep and needing to hold the park brake signal.
3. With the engine off and the parking brake and 12v coach power on, bring the awning to a partially extended position, See Image 2. Locate the edge of the awning with the wind sensor and shake the awning to simulate high winds. The awning should automatically retract when the sensor reads the awning movement.
4. If all the above actions result in their defined outcomes the rework is complete.

Image 2



Image 1

With the awning switched to ON (IF present), and:	When you hit extend or retract, the Awning:
12v Coach Power ON + Engine Off + Parking Brake On	Should Extend. Should Retract.
12v Coach Power Off + Engine Off + Parking Brake On	Should not Extend. Should not Retract.
12v Coach Power Off + Engine On + Parking Brake On	Should not Extend. Should Auto-Retract with Engine Start.
12v Coach Power Off + Engine On + Parking Brake Off	Should not Extend. Should Auto-Retract with Engine Start.
12v Coach Power ON + Engine Off + Parking Brake Off	Should not Extend. Should not Retract.
12v Coach Power ON + Engine On + Parking Brake Off	Should not Extend. Should Auto-Retract with Engine Start.
12v Coach Power ON + Engine On + Parking Brake On	Should not Extend. Should Auto-Retract with Engine Start.

# Blank Slide-

# Wiring Diagram – Carefree BT-12

## BT-12 Wiring Diagram

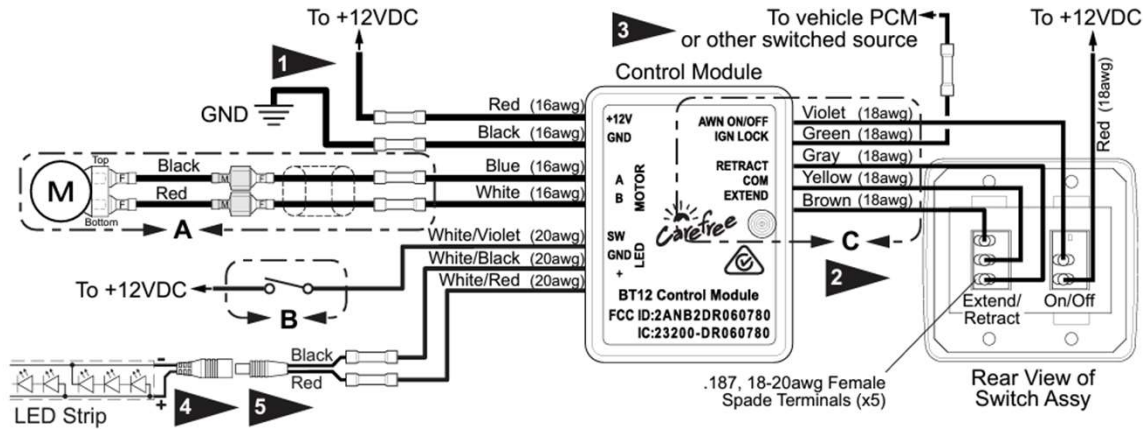

## BT-12 to WGO Harness Connections

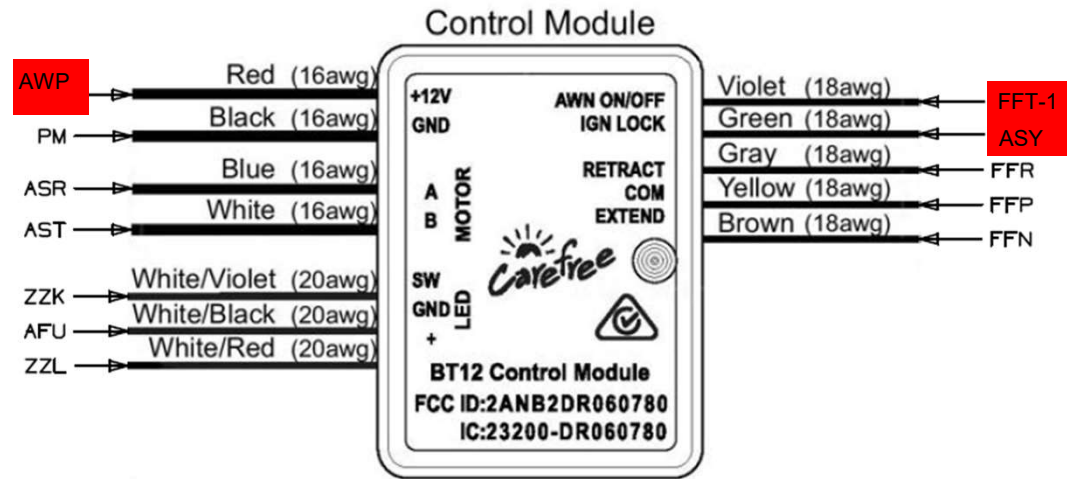

# Wiring Diagram – Harness Gen 1

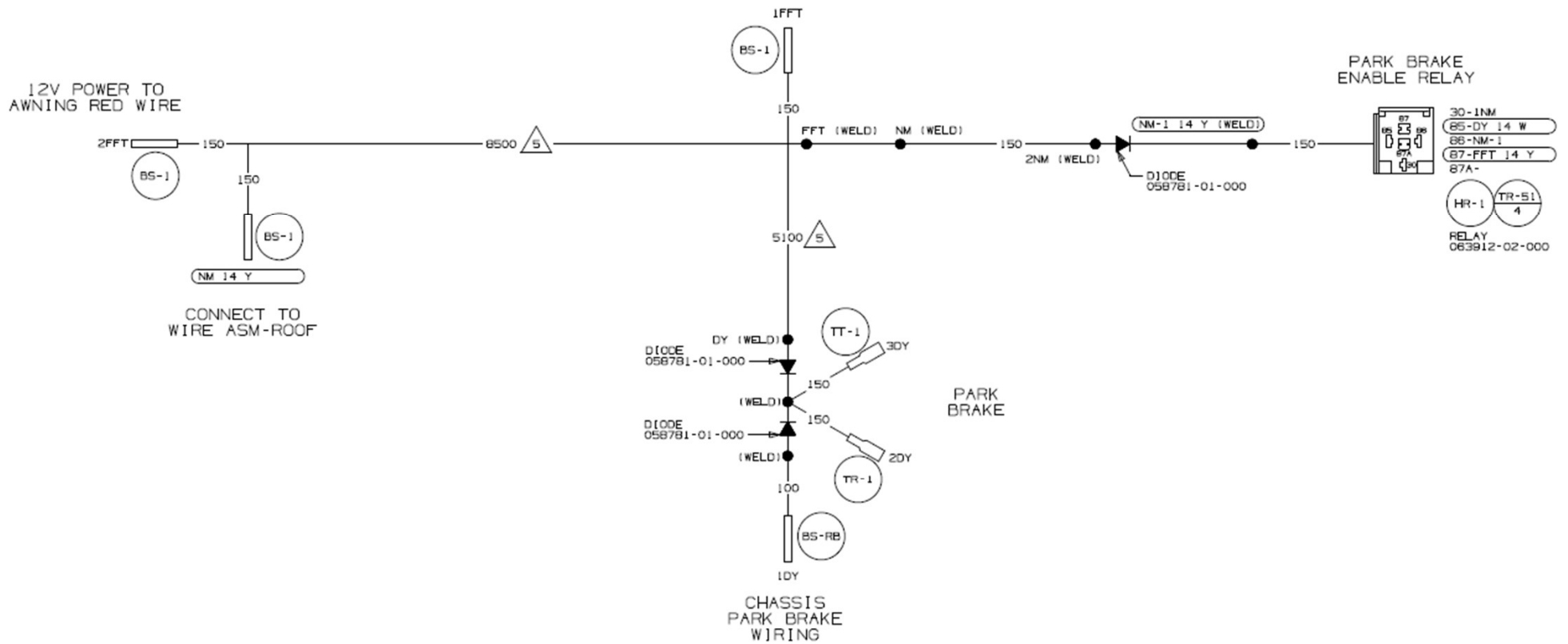

## WIRE ASM-AWNING UPDATE – Gen 1



# Wiring Diagram – Harness Gen 2

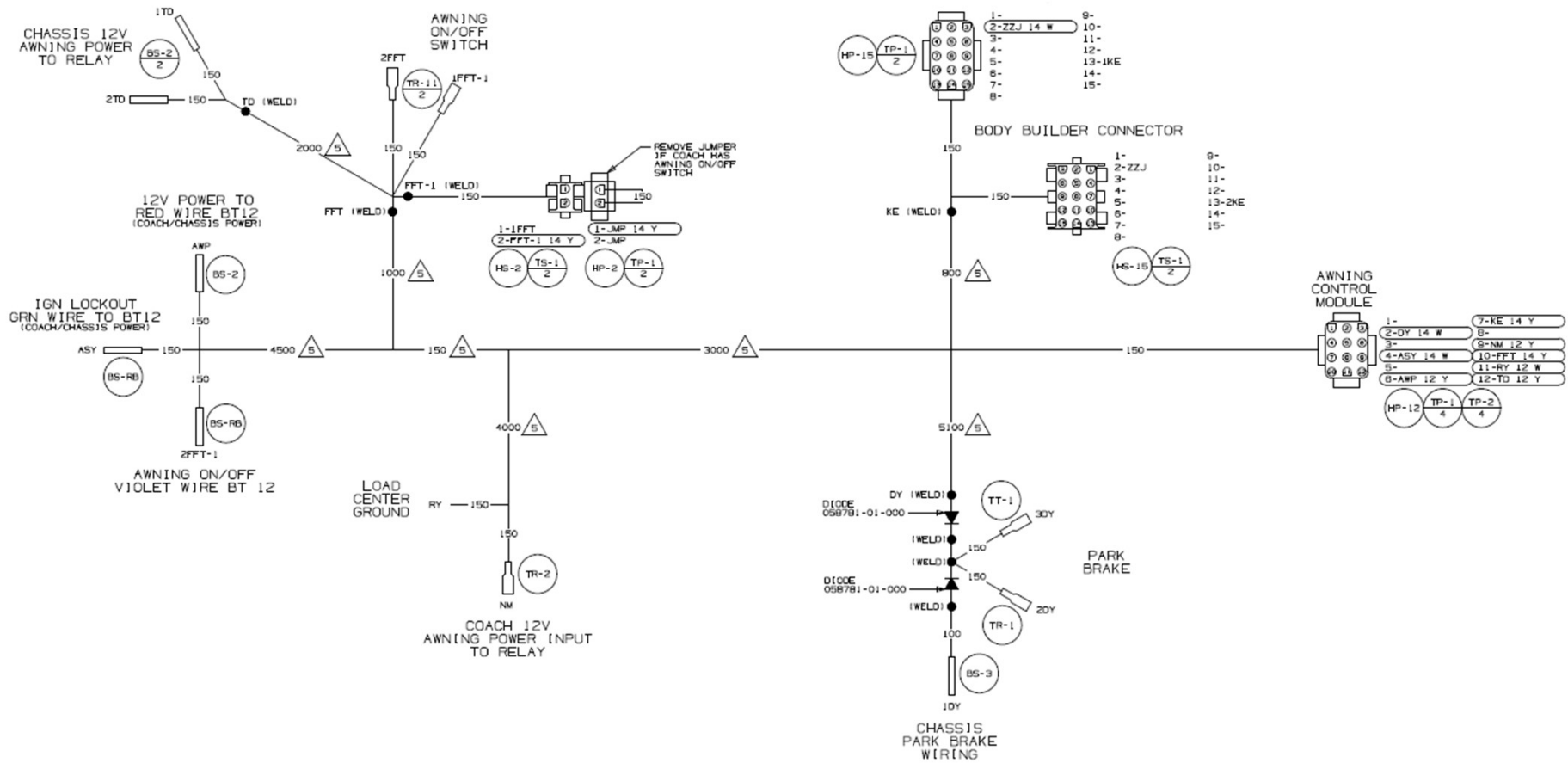

## WIRE ASM-AWNING UPDATE – Gen 2

Read the entire instructions carefully before starting the procedure. If you have any questions, please contact Winnebago Industries Technical Service Department by calling 1-866-653-4329 or by email: [techservice@wgo.net](mailto:techservice@wgo.net). This document is confidential and is intended for dealer use only.