



**Tools Required:**

- Power Drill, 11/32 in Drill Bit, Locking Pliers (or comparable clamp), Torque Wrench

1. Remove seat. See service manual.
2. See Figure 2. Install locking pliers (2) to Pre-Load Adjuster (PLA) (3) and crossmember bracket (4).
3. Remove Original Equipment (OE) 1/4-20 inch screw.

**NOTE**

Use extreme caution to not damage the hydraulic hose connecting the PLA to the shock.

4. Using 11/32 inch drill bit (1), drill through crossmember bracket (4) and PLA (3).
  - a. Using the existing hole on crossmember bracket (4) as a guide.
5. Remove locking pliers (2) and separate the PLA (3) from crossmember bracket (4).
  - a. Remove any burrs from drilling the components.
  - b. Clean metal chips from under the seat area.
  - c. Using Frame Paint Touch-Up Pen (Part No. 93936) or local approved equivalent for international dealers, touch up the brackets from drilling and to prevent any corrosion from forming.
  - d. Allow paint to dry.

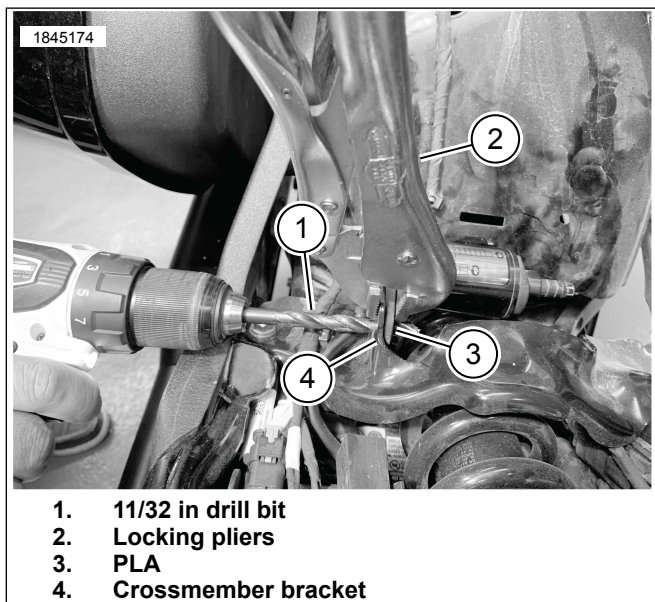

**Figure 2. Rework Mounting Hole**

6. See Figure 3. Install PLA (1) to crossmember (4).
7. Install 5/16-inch screw (3) and locknut (2). Tighten. Torque: 32.8–36.3 N·m (24–27 ft-lbs)

8. Install seat. See service manual.
  - a. After installing seat, pull upward on seat to be sure it is locked in position.
9. Return vehicle to customer and file appropriate recall claim. Refer to Credit Procedure..

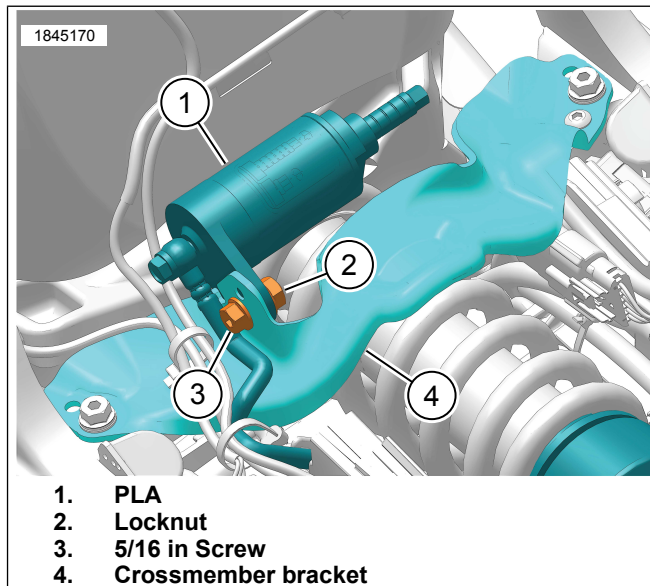

**Figure 3. Recall Kit Installed**

**Credit Procedure**

**NOTE**

Enter bulletin number into comment section of claim.

If vehicle is equipped with a shock other than the OE shock, see credit procedure for inspection only.

Confirm that the vehicle is involved in Safety Recall 0181 and has the OE shock installed. If the status includes an open for Safety Recall 0182, perform only this recall (0181). Safety Recall 0182 will be closed automatically by Harley-Davidson once the 0181 claim is issued credit.

For each vehicle involved in this recall (involvement of Vehicle Identification Number (VIN) has been verified on h-dnet.com ) and currently has the OE shock installed, submit a recall claim per Table 6.

**Table 6. Credit Procedure: Talon/h-dnet.com Warranty Claim System Users**

ITEM	DATA
Claim Type	SRC
Problem Part Number	942
Quantity	Leave Blank
Primary Labor Code <sup>(1)</sup>	2842
Labor Time	0.3 hours
Customer Concern Code	0181
Condition Code	9981
Replacement Part Number	91500114
Quantity	1

*(1) Download may be required*

**Table 7. Credit Procedure: GDP/SAP system users**

ITEM	DATA
Claim Type	Recall Claim
Fix ID-Found in Recall Number	C
Problem Part Number	942
Customer Concern Code	0181
Condition Code	9981

Upon submission of the properly completed claim, you will be credited for 0.3 hours of labor time for performing the procedure, plus appropriate administrative time. Labor time for the repair includes compensation of 0.1 hours for paint pen and drill bit usage in the repair. Credit will also be issued for the recall kit (U.S. only). Submit campaign events on their own claim. Do not mix them with other warranty events.

For each vehicle involved in this recall (involvement of VIN has been verified on h-dnet.com ), **but recall cannot be performed due to installation of non-OE shock component. File this recall as inspection only.**

**NOTE**

*When submitting a claim for ‘Inspection only’, this will close out the recall. Do not make the repair at a later date and file another claim.*

**Table 8. Credit Procedure: Talon/h-dnet.com Warranty Claim System Users - Inspection Only**

ITEM	DATA
Claim Type	SRC
Problem Part Number	942
Quantity	Leave Blank
Primary Labor Code <sup>(1)</sup>	2849
Labor Time	0.1 hours
Customer Concern Code	0181
Condition Code	9982

*(1) Download may be required*

**Table 9. Credit Procedure: GDP/SAP system users**

ITEM	DATA
Claim Type	Recall Claim
Fix ID-Found in Recall Number	I
Problem Part Number	942
Customer Concern Code	0181
Condition Code	9982

Upon submission of the properly completed claim, the dealer will be credited for 0.1 hours of labor time for performing the procedure, plus appropriate administrative time. Submit campaign events on their own claim. Do not mix them with other warranty events.