



## Safety Recall Action Notice 609 Issue 01 - 08.2023

Subject: Manifold Spigot and MAP Sensor Hose			
Bulletin Number	Models Affected	VIN Range	Markets Affected
609	Tiger Sport 660	From VIN AU7774 to VIN BP8765	All Markets
	Trident 660	From VIN AC6898 To VIN BP8778	

### Background Information

Dealers are requested to install a replacement manifold spigot and MAP sensor hose assembly to the inlet manifold as described in the procedure below.

### Customer Contact Instructions

#### NOTICE

STOP DELIVERY OF AFFECTED MOTORCYCLES IMMEDIATELY.

DO NOT deliver a motorcycle affected by this Safety Recall Action Notice to a customer until you have completed, or confirmed completion of, the procedures described in this Safety Recall Action Notice.

Delivering a motorcycle subject to an outstanding Safety Recall Action Notice may contravene local or national laws in your market, territory or country.

Triumph subsidiaries and distributors must instigate a Safety Recall Action in their country in accordance with the national recall code of practice. For vehicles in dealer stock, the safety recall MUST be actioned before delivery to the customer.

Dealers are to prioritise repair of customer owned motorcycles before any unsold motorcycles.

### Identification of Affected Motorcycles

Tiger Sport 660 and Trident 660 motorcycles in the above VIN range.

#### NOTICE

Some affected motorcycles listed in the VIN range will have been modified and repaired by Triumph prior to their release from the factory.

Unmodified motorcycles can be identified by checking the 'VIN Enquiry' on [www.triumphonline.net](http://www.triumphonline.net).

## Warranty Claim Instructions

Bulletin Number	Model	Fault Code	Repair Code	Description	Repair Allowance	Time
609	Tiger Sport 660	012487909	99609	MAP Sensor Hose	0.35 Hrs	
609	Trident 660	012487909	99609	MAP Sensor Hose	0.5 Hrs	

## Genuine Parts Information

Bulletin Number	Part Number	Description	Quantity
609	T1249666	<b>Spigot, MAP Sensor Kit</b> Consisting of: Connector, 4-way - Qty 1 Assembly, Hose, MAP sensor - Qty 1 Inlet Manifold, Spigot - Qty 1 Seal, Intake - Qty 1 Hose, MAP spigot - Qty 1 Hose, MAP Drain - Qty 1 Bung, Hose, MAP - Qty 1 Cap, EVAP - Qty 1 O-ring - Qty 2 Cable Tie - Qty 1	1

## Parts Ordering Instructions

**For Triumph Subsidiary and Overseas Distributor dealers using Triumph Warranty On-Line with Parts Auto Ordering Flag switched on:** Order all repair parts by submitting a New Prior through the Warranty On-Line system. Entering the above repair code in a New Prior will automatically add the parts required and labour times for this Safety Recall Action Notice.

**For Overseas Distributor dealers NOT using Triumph Warranty On-Line or for Overseas Distributor dealers using Triumph Warranty On-Line with Parts Auto Ordering Flag switched off:** Orders should be placed using the normal parts ordering procedure.

## Genuine Parts Return

Dealer to retain parts for 90 days. All parts must be stored in a secure, non-public accessed area and correctly identified with a completed warranty label. Thereafter the parts must be rendered unusable prior to scrapping.

## Other Instructions

Once completed, please mark the Service Record Book that the requirements of this Safety Recall Action Notice have been complied with.

Before returning the motorcycle to the customer, download the latest calibration to the engine electronic control module, chassis electronic control module (if fitted), keyless electronic control module (if fitted) and instruments (if applicable) using the current version of the Triumph diagnostic software.

## Replace the Manifold Spigot and MAP Sensor Hose

### **! WARNING**

Make sure the motorcycle is stabilised and adequately supported.  
Do not support the motorcycle on any ancillary component, the exhaust system or any other non structural parts of the motorcycle frame.  
A correctly supported motorcycle will help prevent it from falling.  
An unstable motorcycle may fall resulting in motorcycle damage, serious injury or death.

### Removal

Remove the following components as described in the Service Manual:

#### For Trident

- Seat
- Battery
- Fuel tank

#### For Tiger Sport

- Seat
- Battery
- Fuel tank side and rear panels, see Fuel Tank Bodywork - Removal

#### All Models

### **NOTICE**

For Tiger Sport, the fuel tank does not need to be removed for the airbox removal.

- Airbox
- Throttle body

1. Detach the MAP sensor and the purge valve hoses from the spigot on inlet manifold

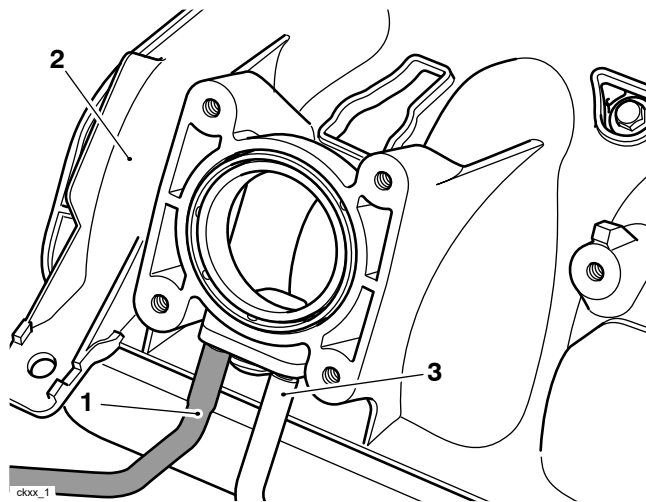

1. MAP sensor hose
2. Inlet manifold
3. Purge valve hose

2. Release the fixing, detach the MAP sensor from the bracket and disconnect the MAP sensor hose.

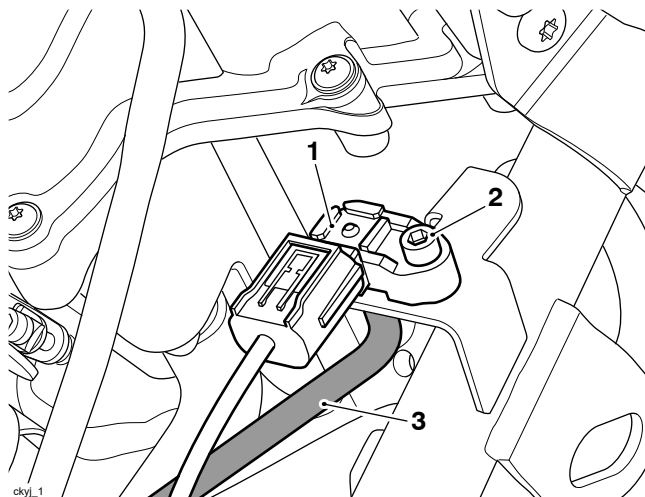

1. MAP sensor (Trident shown)
2. Fixing
3. MAP sensor hose

3. Remove and discard the MAP sensor hose.

## NOTICE

Note the position of the spigot's two O-rings for installation.

4. Release the fixing and remove the spigot and collect the two O-rings. Retain the spigot and the two O-rings as described in the Genuine Parts Return table.

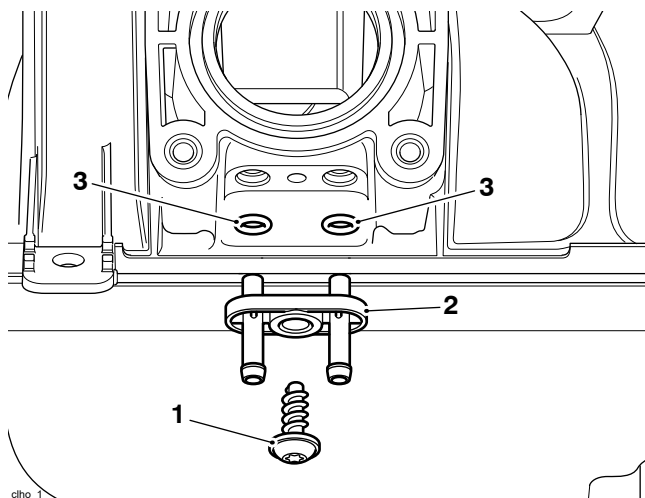

1. Fixing
2. Spigot
3. O-rings

## NOTICE

The left hand outrigger cover is removed to allow access for securing the new MAP sensor drain hose to the frame.

- 
5. Remove the swinging arm pivot cover from the left hand outrigger.

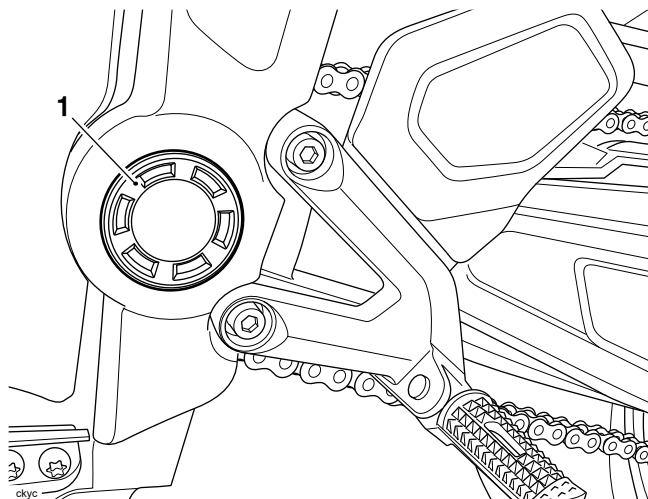

**1. Swinging arm pivot cover (left hand side shown)**

6. Release the fixing, detach the retaining clips and remove the left hand outrigger cover.

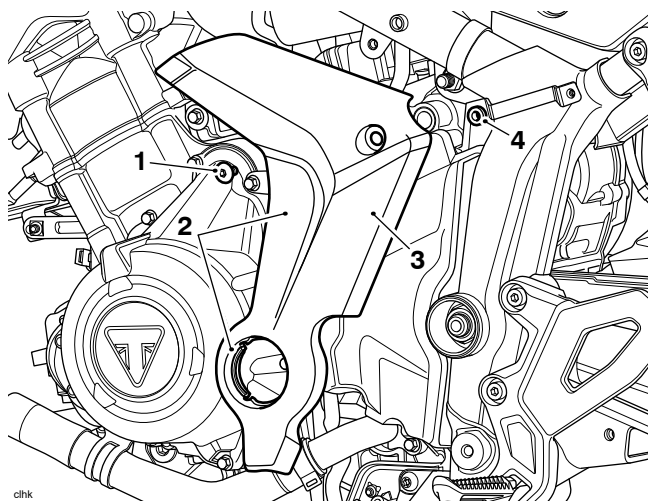

- 1. Fixing**  
**2. Retaining clips locations**  
**3. Outrigger cover**  
**4. Retaining clip grommet**

## Installation

### NOTICE

Make sure the new O-rings are fitted to the spigot pipes without the bulge on the end of them.  
When fitting the spigot to the inlet manifold, make sure the spigot pipes without the bulge are inserted into the inlet manifold.

1. Fit the two new O-rings to the new spigot as noted for removal.
2. Fit the spigot to the inlet manifold and tighten the fixing to 5 Nm.

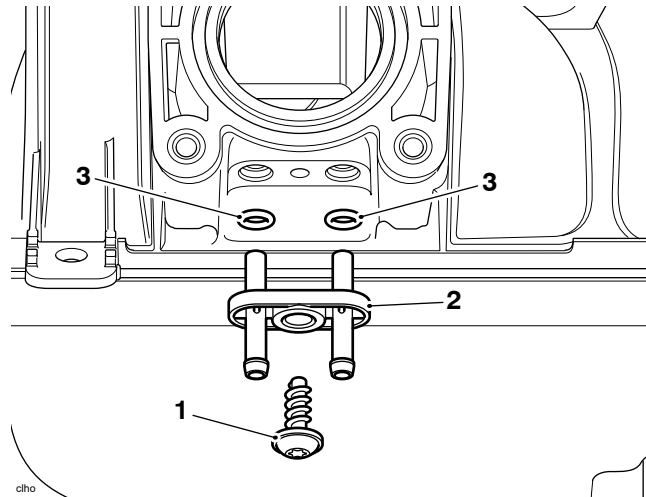

1. Fixing
2. Spigot
3. O-rings

3. Assemble the six components of the MAP sensor hose assembly as shown in the illustration below.
4. Fit the drain hose plug to the open end of the drain hose.

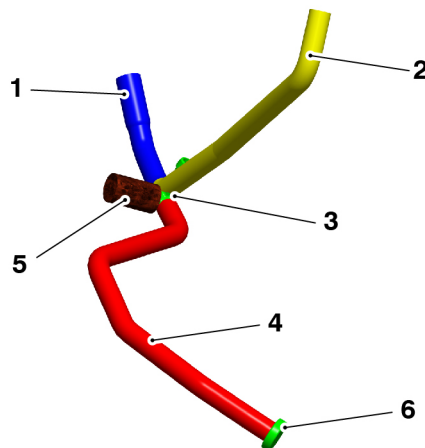

1. Hose, to inlet manifold
2. Hose, to MAP sensor
3. Four way connector
4. Drain hose
5. Blanking cap
6. Drain hose plug

## NOTICE

Before fitting the MAP hose assembly, make sure that the clamp securing the breather hose to the engine breather cover has its lugs pointing towards the right hand side of the motorcycle.

5. Check the position of the breather hose clamp. If required, reposition so the clamp lugs are pointing to the right hand side of the motorcycle.

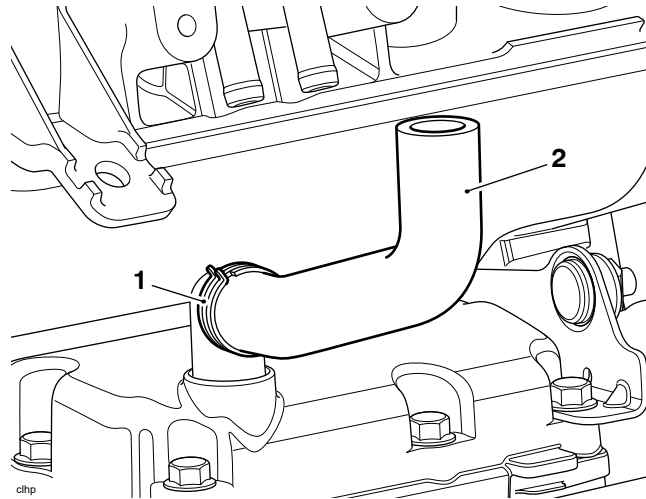

1. Clamp
2. Breather hose

## NOTICE

When fitting the MAP hose assembly to the spigot on the inlet manifold, make sure the blanking cap on the four way connector is pointing to the left hand side of the motorcycle.  
The hose for the MAP sensor must be from the top of the four way connector.

6. Attach the MAP sensor and the purge valve hoses to the spigots on the inlet manifold.

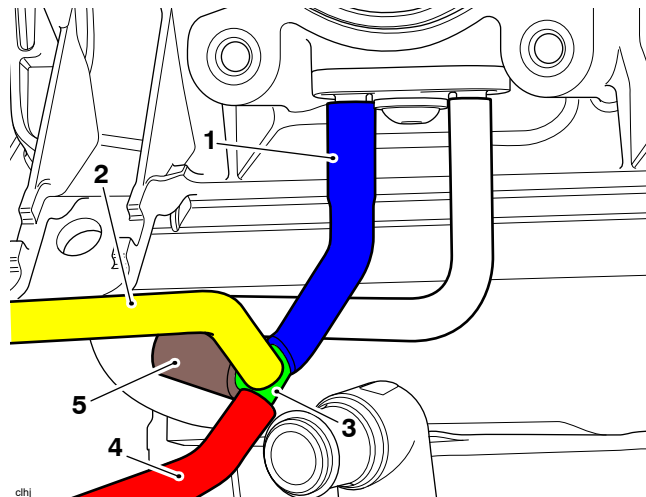

1. Hose, to inlet manifold
2. Hose, to MAP sensor
3. Four way connector
4. Drain hose
5. Blanking cap
7. Fit the MAP sensor hose to the MAP sensor.

8. Fit the sensor to the bracket, tighten the fixing for:
  - Trident 660 to 5 Nm.
  - Tiger Sport 660 to 2.5 Nm.

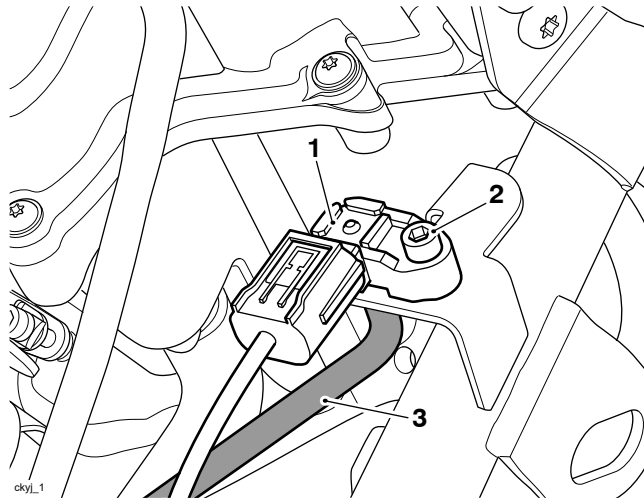

1. MAP sensor (Trident shown)
2. Fixing
3. MAP sensor hose

## NOTICE

Do not over tighten the cable tie.

Over tightening the cable tie will crush the MAP sensor drain hose.

9. Route the drain hose to the left hand side of the frame, as shown in the illustration below.
10. Secure the drain pipe to the frame with a cable tie as shown in the illustration below.

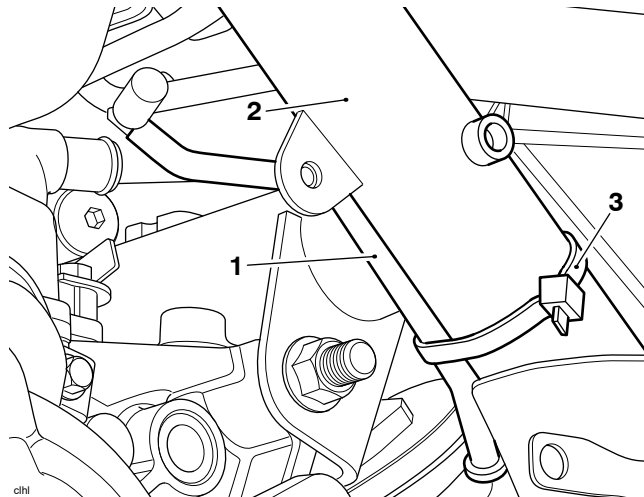

1. Drain hose
2. Frame
3. Cable tie

11. Fit the left hand outrigger cover and tighten the fixing to 3 Nm.



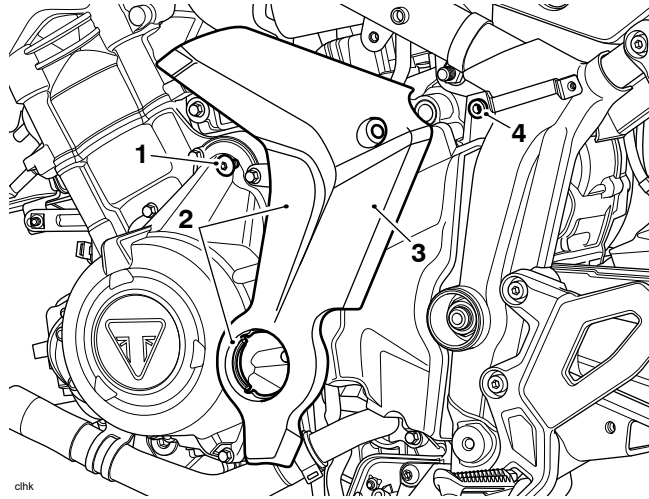

1. Fixing
2. Retaining clips location
3. Outrigger cover
4. Retaining clip grommet

## NOTICE

Note that on the inside surface of the pivot cover there are L and R markings. When fitting the left hand cover, make sure that the L marking aligns with the alignment mark on the outrigger cover.

12. Refit the swinging arm pivot covers, using the alignment marks.

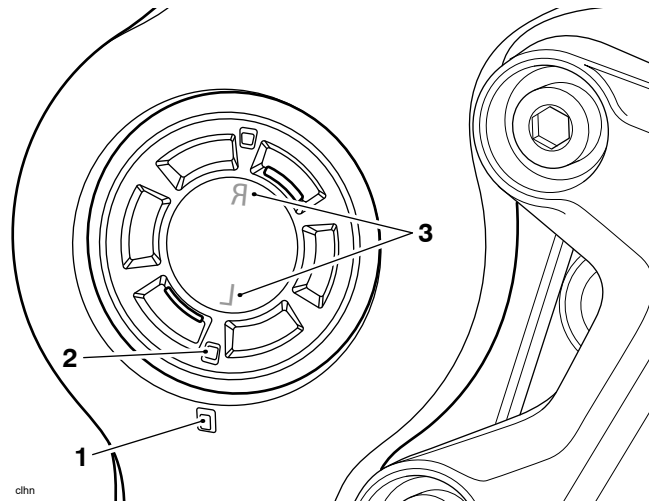

1. Alignment mark, outrigger cover
2. Alignment mark, pivot cover
3. L and R markings, shown for clarity

Install the following components as described in the Service Manual:

### All Models

- Throttle body
- Airbox

### For Trident

- Fuel tank
- Battery
- Seat

---

**For Tiger Sport**

- Fuel tank side and rear panels, see Fuel Tank Bodywork - Removal
- Battery
- Seat

**Maintenance**

At every 10,000 mile service the MAP sensor drain hose is to be drained using the procedure described in Appendix A.

## Appendix A

### MAP Sensor Drain Hose - Draining

The MAP sensor drain hose is to be drained every 10,000 miles.

#### NOTICE

For best results use either a vacuum brake bleeding kit, a vacuum hand pump or an oil and brake fluid syringe to extract the oil from the drain hose.

Perform the following operations

- Seat - Removal
- Battery - Removal

#### NOTICE

To prevent damage to the MAP sensor, the MAP hose must be detached from the MAP sensor.

1. Release the fixing, detach the MAP sensor from the bracket and disconnect the MAP sensor hose.

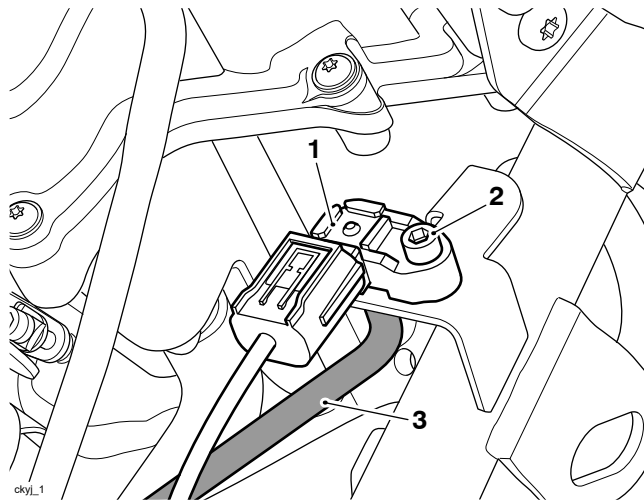

1. **MAP sensor (Trident shown)**
2. **Fixing**
3. **MAP sensor hose**

2. Remove the swinging arm pivot cover from the left hand outrigger.

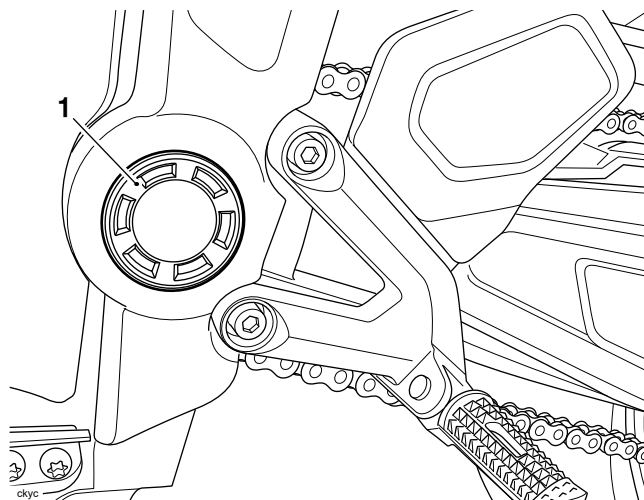

1. **Swinging arm pivot cover (left hand side shown)**

3. Release the fixing, detach the retaining clips and remove the left hand outrigger cover.

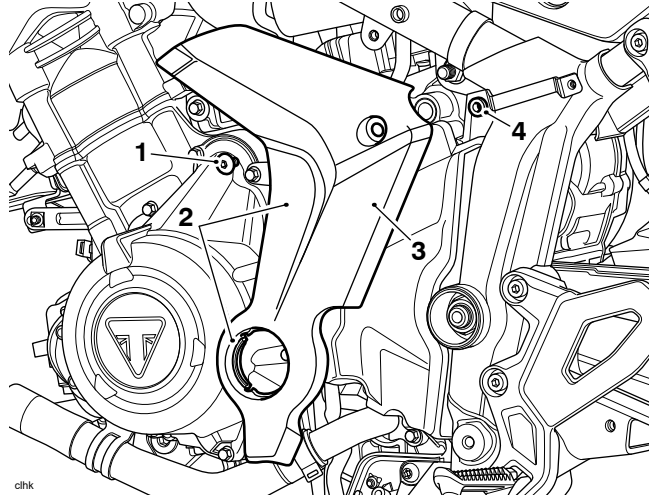

1. Fixing
2. Retaining clips locations
3. Outrigger cover
4. Retaining clip grommet

4. Remove the cable tie securing the drain hose to the frame.
5. Remove the drain hose plug and connect a suitable vacuum device or syringe to extract any oil from the drain hose.

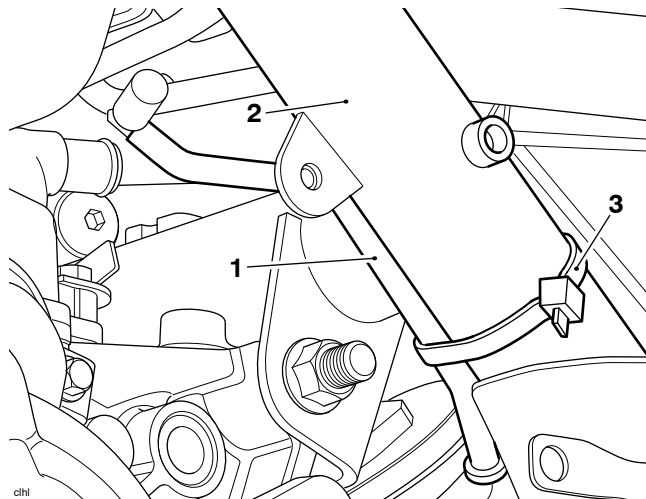

1. Cable tie
2. Drain hose plug

6. When the oil is drained, refit the drain hose plug.

## NOTICE

Do not over tighten the cable tie.  
Over tightening the cable tie will crush the MAP sensor drain hose.

7. Route the drain hose to the left hand side of the frame, as shown in the illustration below.

8. Secure the drain pipe to the frame with a cable tie as shown in the illustration below.

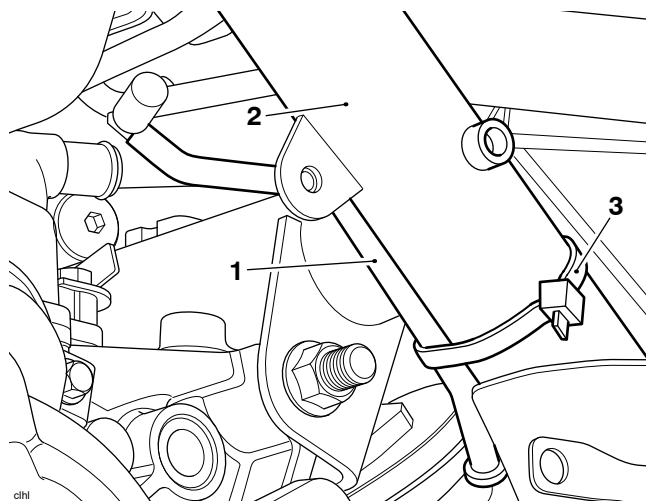

1. Drain hose
2. Frame
3. Cable tie

9. Fit the left hand outrigger cover and tighten the fixing to 3 Nm.

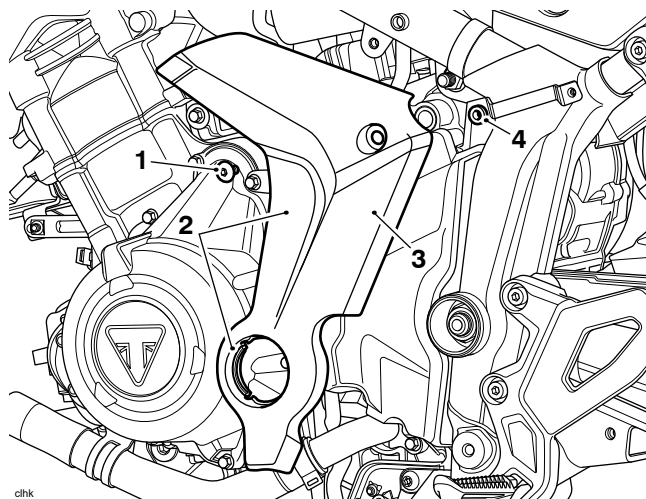

1. Fixing
2. Retaining clips location
3. Outrigger cover
4. Retaining clip grommet

## NOTICE

Note that on the inside surface of the pivot cover there are L and R markings.

When fitting the left hand cover, make sure that the L marking aligns with the alignment mark on the outrigger cover.

10. Refit the swinging arm pivot covers, using the alignment marks.

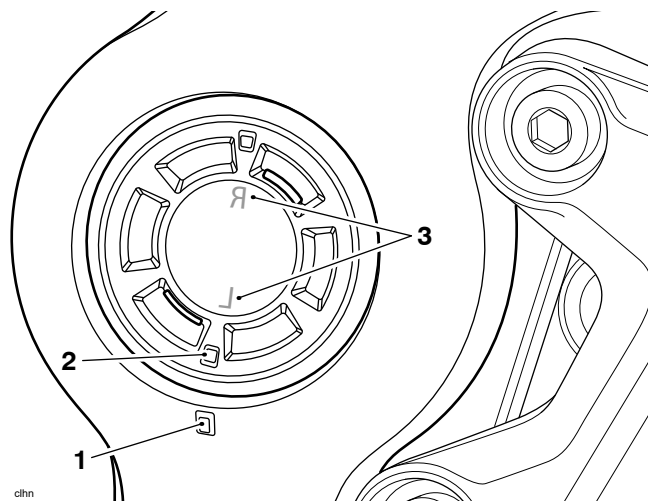

- 1. Alignment mark, outrigger cover
- 2. Alignment mark, pivot cover
- 3. L and R markings, shown for clarity

- 11. Fit the MAP sensor hose to the MAP sensor.
- 12. Fit the sensor to the bracket, tighten the fixing for:
  - Trident 660 to 5 Nm.
  - Tiger Sport 660 to 2.5 Nm.

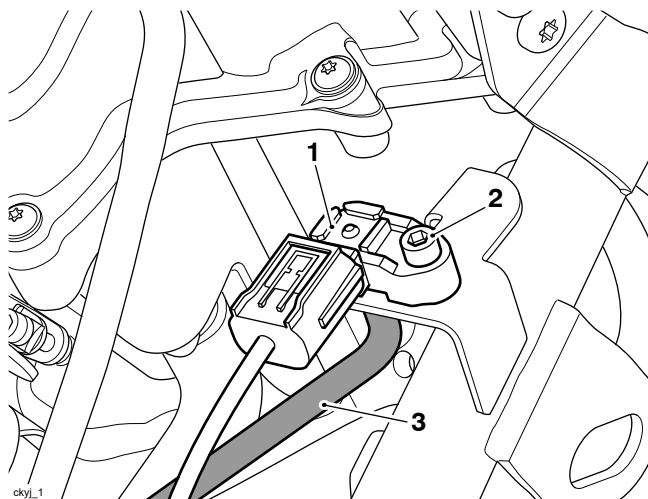

- 1. MAP sensor (Trident shown)
- 2. Fixing
- 3. MAP sensor hose

Perform the following operations

- Battery - Installation
- Seat - Installation

**Circulation**

Initial and date when read and return to central file holder

Service Manager	Parts Manager	Sales Manager	Workshop Supervisor	Technician 1	Technician 2