

# TECHNICAL INSTRUCTIONS

FOR

**SAFETY RECALL 23TB09**

**Interim Repair**

**INCREASED RISK OF FIRE DUE TO FUEL LEAK**

**CERTAIN 2022 – 2023 MODEL YEAR TUNDRA HV  
CERTAIN 2022 – 2023 MODEL YEAR TUNDRA**

**UPDATED**

Update 1/10/2023: Steps 5 and 6 have been updated.

The repair quality of covered vehicles is extremely important to Toyota. All dealership technicians performing this repair are required to successfully complete the most current version of the E-Learning course “Safety Recall and Service Campaign Essentials”. To ensure that all vehicles have the repair performed correctly; technicians performing this repair are required to have currently completed the following courses:

- T4535 – Steering, Suspension & Handling

Always check which technicians can perform the repair by logging on to <https://www.uotdealerreports.com>. It is the dealership’s responsibility to select technicians with the above course completed to perform this repair. Carefully review your resources, the technician’s skill level, and ability before assigning technicians to this repair. It is important to consider technician days off and vacation schedules to ensure there are properly trained technicians available to perform this repair at all times.

# I. OPERATION FLOW CHART

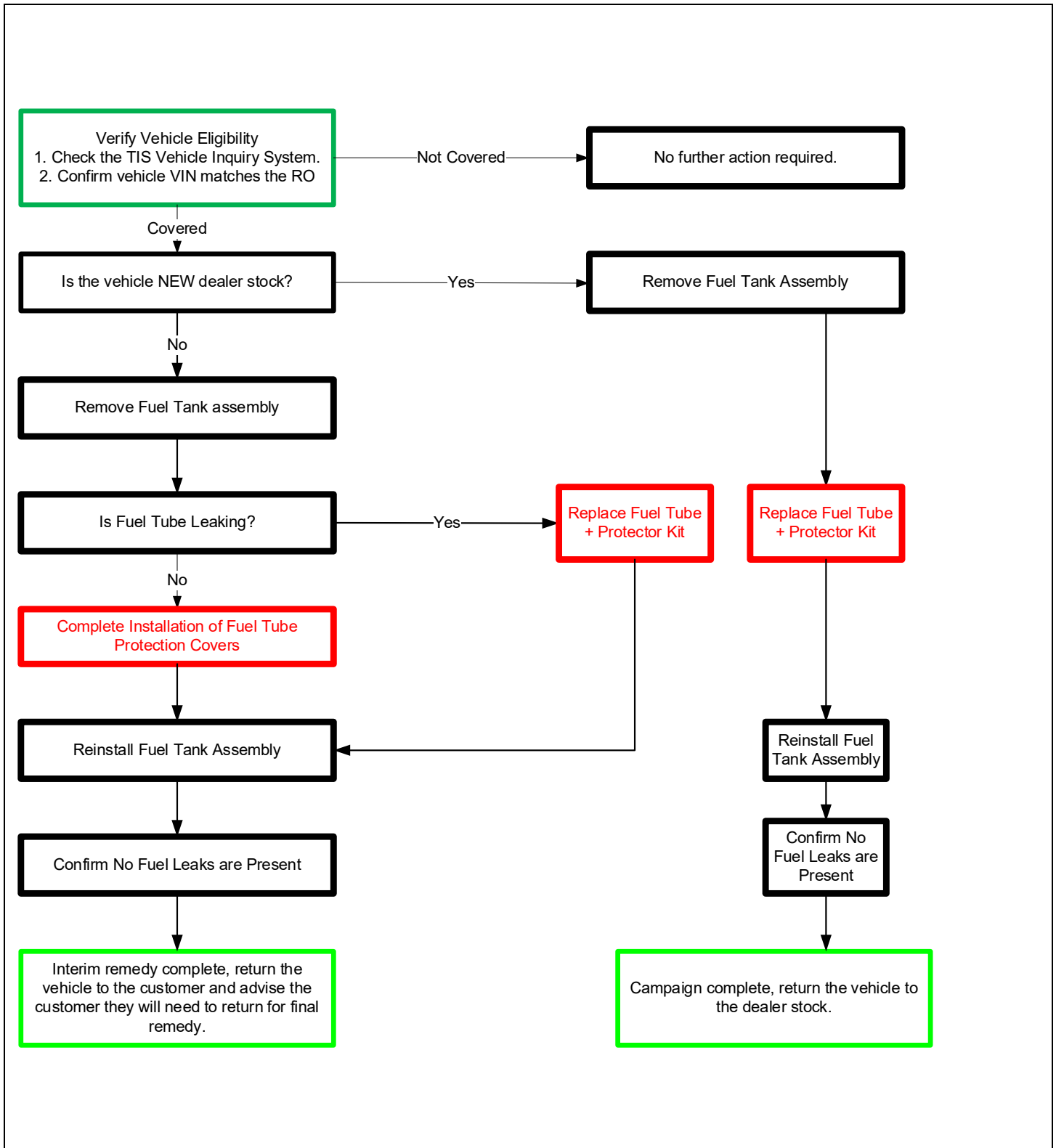

## II. IDENTIFICATION OF AFFECTED VEHICLES

### 1. CHECK VEHICLE FOR CAMPAIGN ELIGIBILITY

- Compare the vehicle's VIN to the VIN listed on the Repair Order to ensure they match.
- Check the TIS Vehicle Inquiry System to confirm the VIN is involved in this Campaign, and that it has not already been completed.

**NOTE: TMNA warranty will not reimburse dealers for repairs completed on vehicles that are not affected or were previously completed, even by another dealer.**

## III. PREPARATION

### A. PARTS

#### In Service Vehicles

- Order the following parts under CPOR for the Interim Repair.

Part Number	Part Description	Quantity
04003-4410C	Protector kit	1

#### In Service Vehicles with Leaking Fuel Tube

- Order 04003-4410C through CPOR and order 77209-0C181 through MAC D Request.

Part Number	Part Description	Quantity
77209-0C181	TUBE SUB-ASSY, FUEL TANK MAIN	1
04003-4410C	Protector kit	1

#### Dealer Stock Vehicles

- The following parts will be pre-deployed to the dealer.

Part Number	Part Description	Quantity
77209-0C181	TUBE SUB-ASSY, FUEL TANK MAIN	1
04003-4410C	Protector kit	1

### B. TOOLS & EQUIPMENT

<ul style="list-style-type: none"> <li>Techstream</li> <li>Air Blow Gun</li> <li>Transmission jack</li> </ul>	<ul style="list-style-type: none"> <li>Standard Hand Tools</li> <li>Jack stand</li> </ul>	<ul style="list-style-type: none"> <li>Torque Wrench</li> <li>Gas Caddy (Minimum 25-gallon capacity)</li> <li>Fuel Tube Protection Kit Installation Template*</li> </ul>
---	---	--

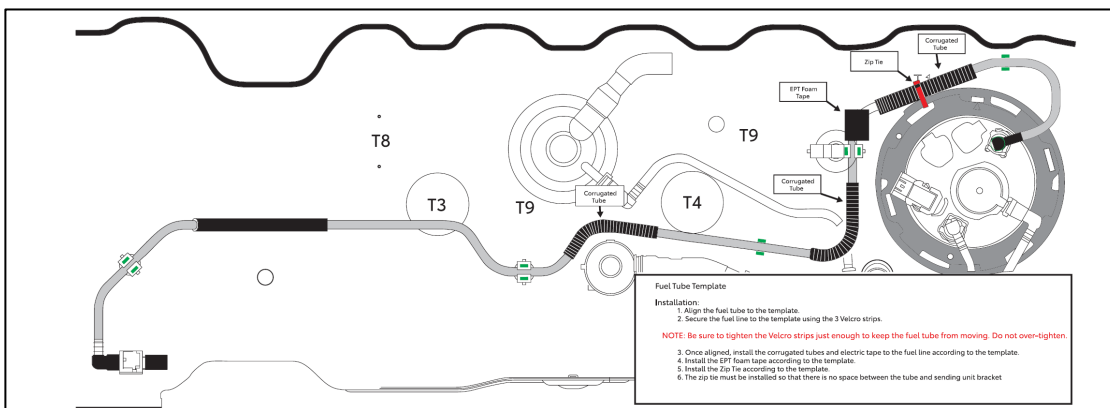

\*The Fuel Tube Protection Kit Installation Template was shipped to each dealership (ATTN: Service Manager) just before the launch of the interim repair. Please check with your Service Manager if you do not have the template before proceeding.

**C. MATERIALS**

• Brake Cleaner	• Protective Glasses	• Rags
• Protective Gloves		

**IV. WORK PROCEDURE TABLE OF CONTENTS**

**BACKGROUND** ..... [SECTION V.](#)  
**SAFETY PRECAUTIONS** ..... [SECTION VI.](#)  
**COMPONENTS** ..... [SECTION VII.](#)  
**DETERMINE PROPER REPAIR PROCEDURE** ..... [SECTION VIII.](#)  
**REPAIR PROCEDURE**..... [SECTION IX.](#)  
**APPENDIX** ..... [SECTION X.](#)

**V. BACKGROUND**

The subject vehicles are equipped with a plastic fuel tube that could move and rub against a brake line and develop a fuel leak. A fuel leak in the presence of an ignition source could increase the risk of fire.

**VI. SAFETY PRECAUTIONS**

	<ul style="list-style-type: none"> <li>• Always remember “SAFETY FIRST”.</li> <li>• When installing/uninstalling the fuel system components, keep safety first in mind and carefully observe the following instructions to avoid fire.</li> <li>• Check each item in the appropriate section for each vehicle.</li> </ul>
---	---

**CAUTION:**

- When installing/uninstalling the fuel system components, keep safety first in mind and carefully observe the following instructions to avoid accidents:
  - a. When working on the fuel system, display a Flammable - Keep Fire Away sign.
  - b. Smoking is prohibited nearby.
  - c. Perform this work in an area where there are no sparks nearby from the operation of welders, grinders, drills, electric motors, stoves, etc.
  - d. **DO NOT** use electrical devices nearby because they can become hot, and the operation of power switches can generate sparks.
  - e. **DO NOT** use iron or steel hammers while working, because they may generate sparks.
  - f. **DO NOT** start engines even in adjacent stalls.
  - g. Prepare fire extinguishers before starting any work.
  - h. Perform this work in a well-ventilated area (natural ventilation). **DO NOT** use exhaust fans or electric fans, because their motors might generate sparks.
  - i. Since it is possible for fuel vapor to build up, **DO NOT** work in or near a pit.
  - j. If fuel is spilled, use shop towels or similar material to quickly wipe it up and then use compressed air to diffuse the fuel vapor.
  - k. Shop towels and other materials that have come into contact with fuel should be dried in a well-ventilated area and then disposed of as appropriate.

## VII. COMPONENTS

85 L Fuel Tank

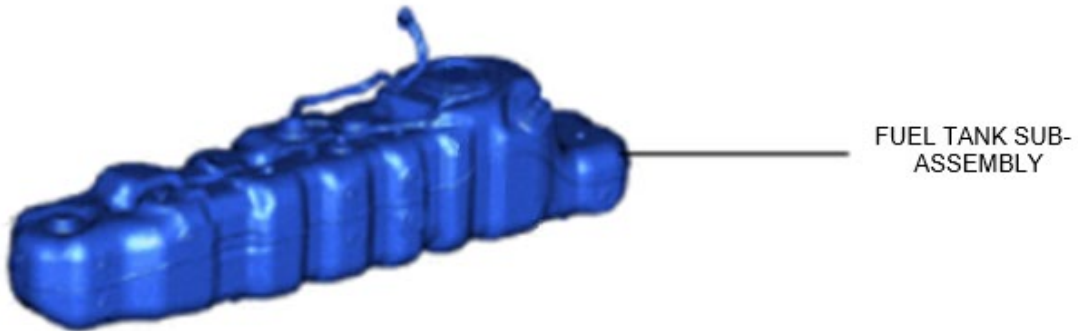

122 L Fuel Tank

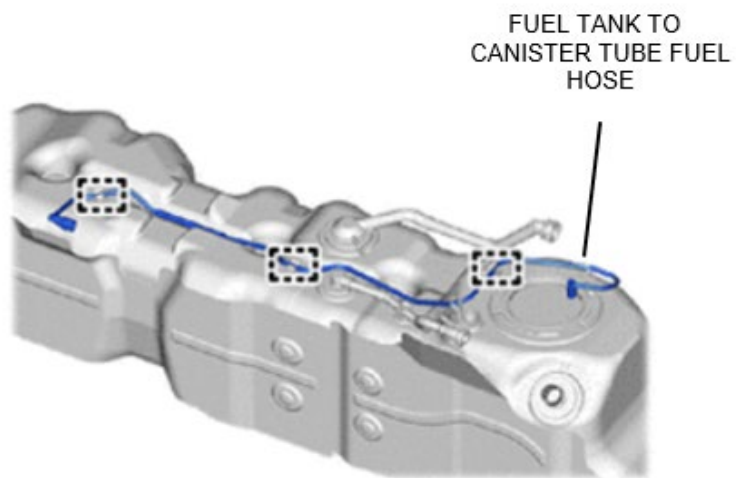

### VIII. DETERMINE PROPER REPAIR PROCEDURE

Determine if the vehicle is dealer stock. Follow the flow below to determine which repair needs to be completed.

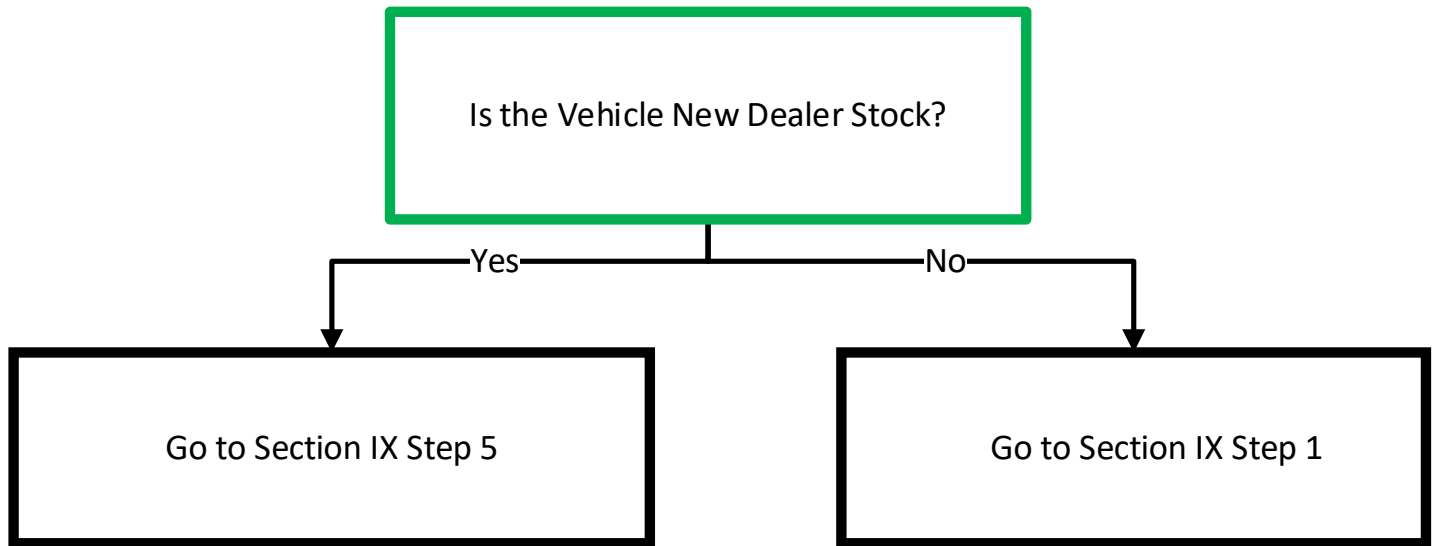

## IX. REPAIR PROCEDURE



### 1. CHECK FOR DTCS

- a. Using GTS+, check for Diagnostic Trouble Codes.

**NOTE:** This Safety Recall covers only the installation of the fuel line kit and associated parts. It does not cover the diagnosis or replacement of any other parts of the vehicle.

### 2. REMOVE FUEL TANK

- a. Remove fuel from fuel tank unless  $\frac{1}{4}$  tank or less is present.

#### REMOVAL TIP: FUEL LEVEL

If the fuel level inside the fuel tank is above the specified level, fuel may overflow from the fuel tank during the removal of the fuel tube assembly. Confirm the fuel level in the vehicle is below the specified level before proceeding. If necessary, drain fuel from the tank.

FUEL LEVEL RECOMMENDATIONS			
Less than full	$\frac{3}{4}$ or less	$\frac{1}{4}$ or less	Empty
			

**Note:** If fuel needs to be removed from the tank, be sure to recover it into an approved fuel recovery system. Suitable systems are available from the [Toyota Approved Dealer Equipment](#) website.

- b. Remove the fuel tank following the repair manual steps:

**Step 4 and 5 can be omitted from the fuel tank removal process.**

**NOTE:** Driveline and exhaust do not need to be removed.

- When lowering the fuel tank, take caution to not lower the tank too far as the wire harness may pull on the fuel tank sending unit connectors causing damage.

- [V35A-FTS \(FUEL\): FUEL TANK: REMOVAL; 2022 - 2024 MY Tundra Tundra HV](#)

### 3. CONFIRM CURRENT CONDITION OF THE FUEL TUBE

a.) Inspect fuel tube in the 3 locations and be cautious of potential leak when draining fuel tank.

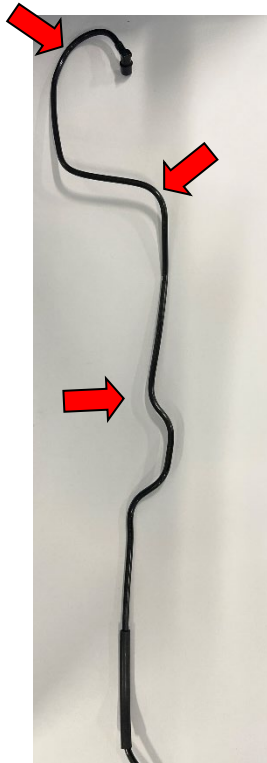

Is the Fuel Line Leaking?

Yes

No

Go to Step 5

Go to Step 4



#### 4. INSTALL REPAIR KIT ONTO FUEL TUBE

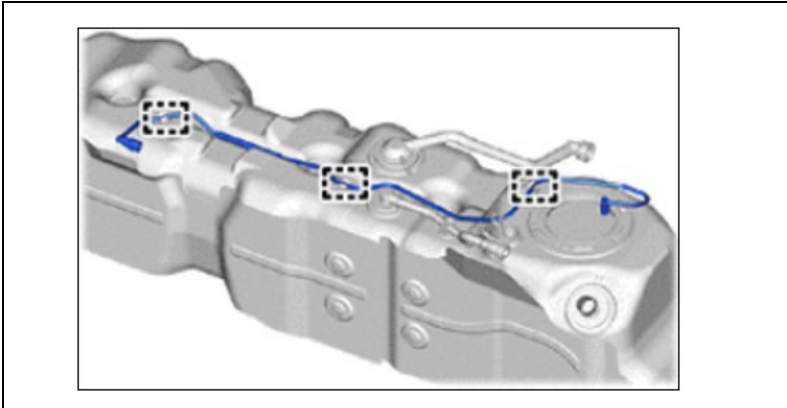

- a. Remove the fuel tank to canister fuel hose.
1. Remove the three clips securing the fuel tube to the fuel tank assembly.

"a	Retainer
"b	Fuel Pipe
"c	Fuel Tube Connector
"d	O-ring
	Pull out
	Pull off

- b. Remove the fuel tube connection at the fuel sending unit.

**NOTE:** Remove any foreign matter on the fuel tube connector and fuel pipe before performing this work.

1. Pull out the retainer to detach the lock claws and pull off the fuel tube connector.
2. If the fuel tube connector and fuel pipe are stuck, push and pull the fuel tube connector to release it. Pull the fuel tube connector off the fuel pipe carefully.
3. Remove the fuel tube.
4. Remove any residual fuel from inside the tube before continuing.



**NOTE:** If the fuel tube has been replaced previously it will already have corrugated tube applied. This tube will still require a repair kit. Please keep additional pieces from the kit and use them later if required. This vehicle will still need to come back for the remedy when available.

1. Skip to step d. and use the template to install the **zip tie only**. The additional corrugated tube and EPT foam is not required.

	<p>If the fuel tube has been replaced previously, please use op code 23TB09R1 for Interim Remedy</p>
--	--

### Fuel Tube Protection Kit Installation Template

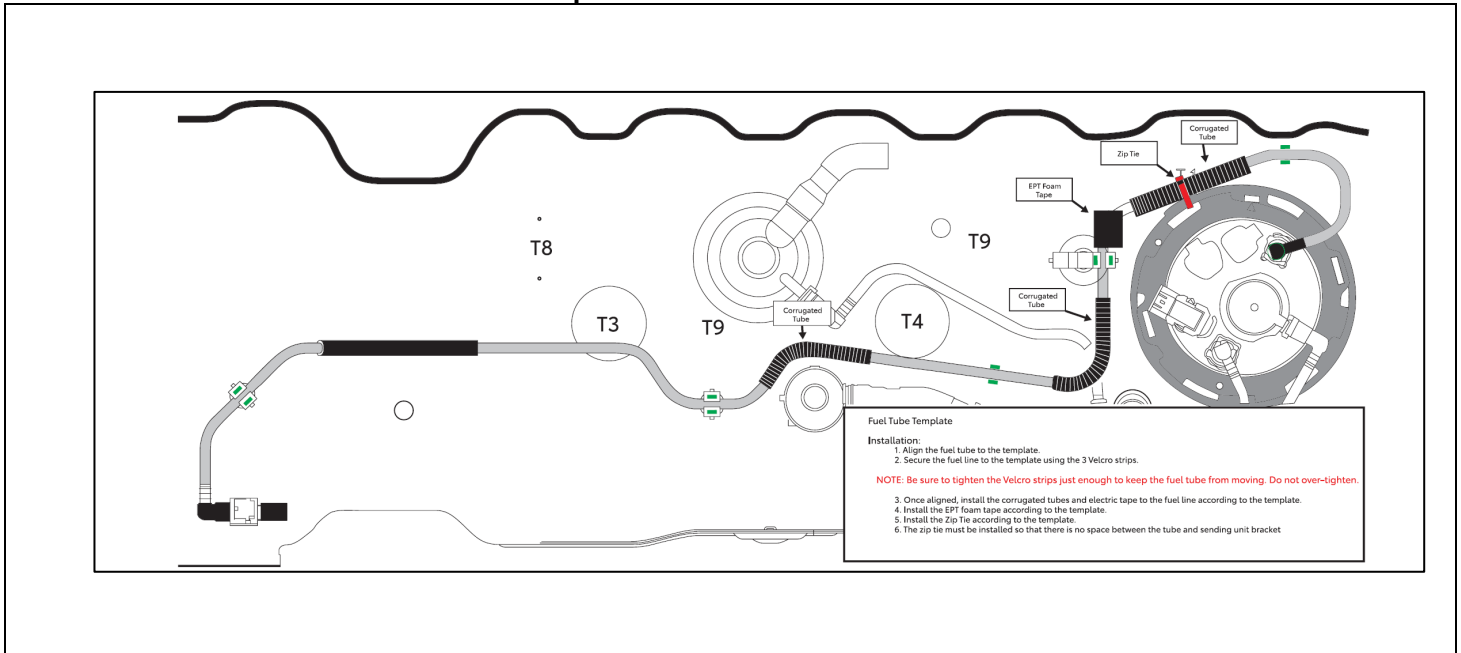

- c. Install the repair kit onto the fuel tank to canister tube fuel hose.
  1. Align the fuel tube to the provided Fuel Tube Protection Kit Installation Template.
  2. Secure the fuel tube to the template using the 3 Velcro strips.

**NOTE:** Be sure to tighten the straps just enough to keep the fuel tube from moving. Do not over-tighten.

- Once aligned, install the corrugated tubes in the 3 locations specified and apply electric tape to the fuel line according to the template. This tape should completely cover the corrugated tube. The tape should overlap onto the tube as it will secure the corrugated tube to the fuel tube.

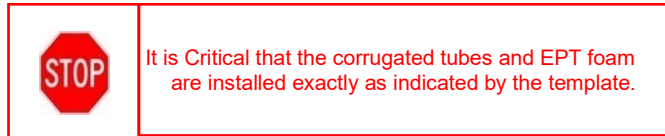
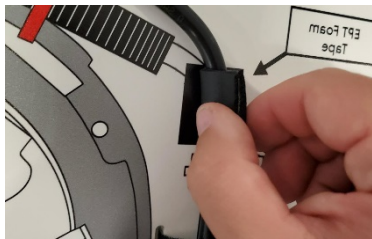
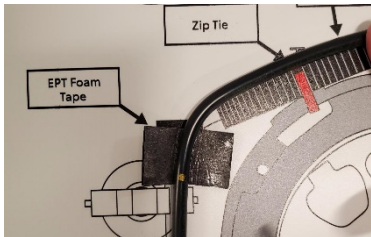
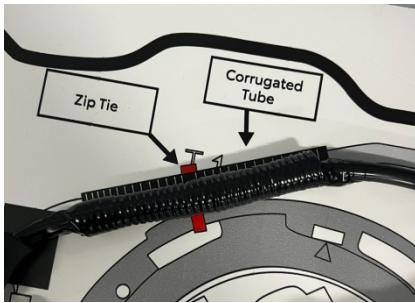
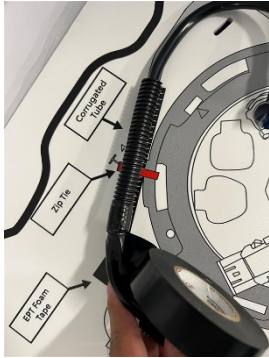

- Position the EPT foam tape according to the template by slightly lifting the fuel tube in the location marked “EPT Foam Tape”. Remove the paper backing and slide the foam tape into position with the adhesive side facing up.
- Once in position, lower the fuel tube and wrap the EPT Foam Tape around the fuel tube so that the adhesive sides meet. Press the adhesive side together firmly to ensure a secure bond is formed.

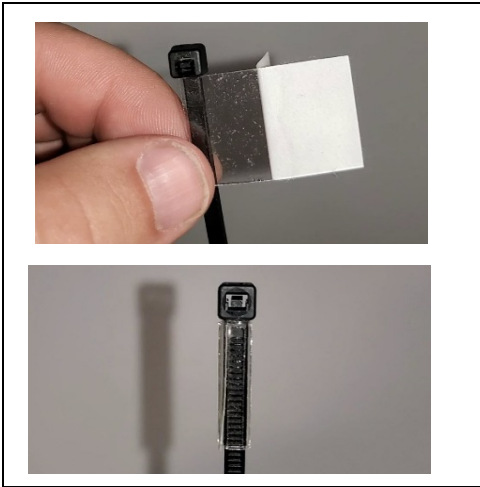

6. Prepare the zip tie for installation by adding protective clear tape near the head of the zip tie.
7. Slightly peel the backing paper off the clear tape and align the short adhesive side of the clear tape with the edge of the zip tie. Press the tape firmly to the zip tie and continue to wrap the tape around the zip tie.
8. Once completely wrapped, press firmly on the clear tape to ensure a secure bond is formed.
5. Remove the fuel tube from the template.

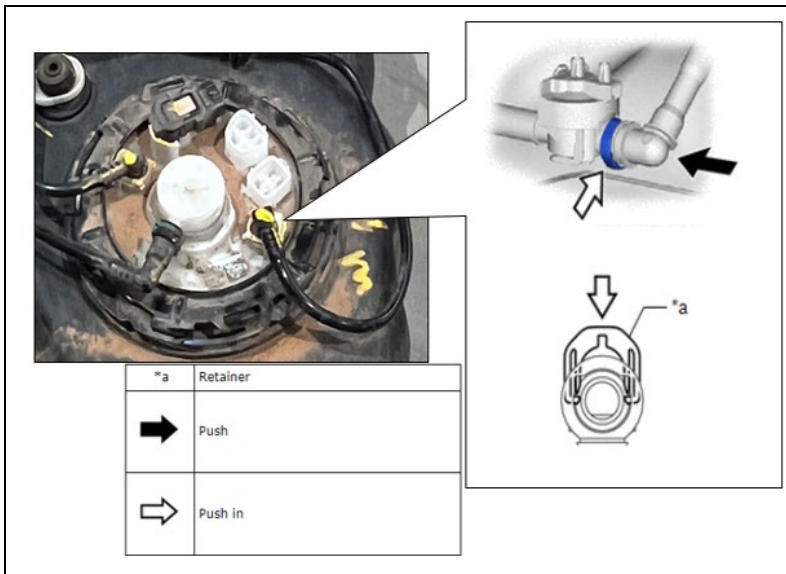

d. Install the fuel tube connection.

1. Align the fuel tube connector with the fuel pipe, push the fuel tube connector onto the fuel pipe, and then push in the retainer to secure the connection.

**NOTE:** Confirm that the retainer makes a "click" sound when pushed.

2. After connecting the fuel line, check that the fuel tube connector is securely connected by pulling on it.

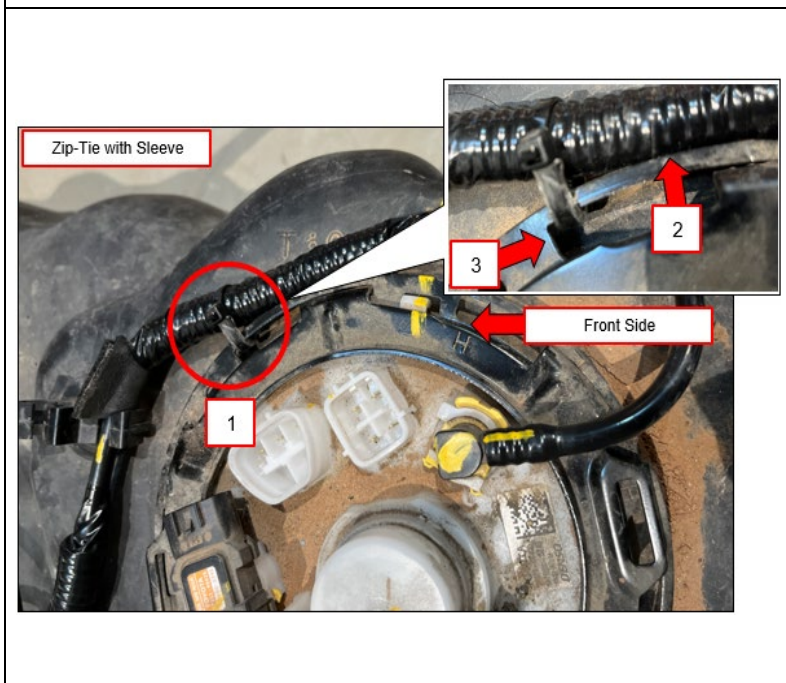

e. Install a zip tie with protective sleeve to the fuel tube.

1. Secure the fuel tube to the fuel-sending unit using a zip tie with a protective sleeve as seen in the photo illustration.
2. The zip tie must be installed so that there is no space between the tube and the sending unit bracket.
3. Be sure that the zip tie is installed in the frontmost position of the fuel sending unit bracket.

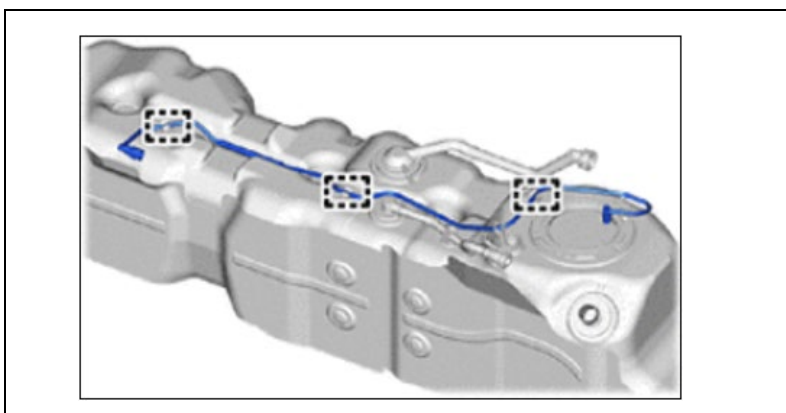

f. Install the fuel tube to the fuel tank clips.

1. Install the fuel tube to the three clips securing it to the fuel tank assembly.

g. [Proceed to Step 7.](#)

## 5. REPLACE FUEL TUBE WITH A **NEW** ONE (Dealer Stock or Active Fuel Leak Only)

- a. Remove the fuel tank to canister fuel hose.

**NOTE: This new tube replacement will still require a repair kit. use the template to install the ZIP TIE ONLY. The additional corrugated tube and EPT foam is not required.**

**Please keep additional pieces from the kit and use them later if required.**

1. Remove the three clips securing the fuel tube to the fuel tank assembly.

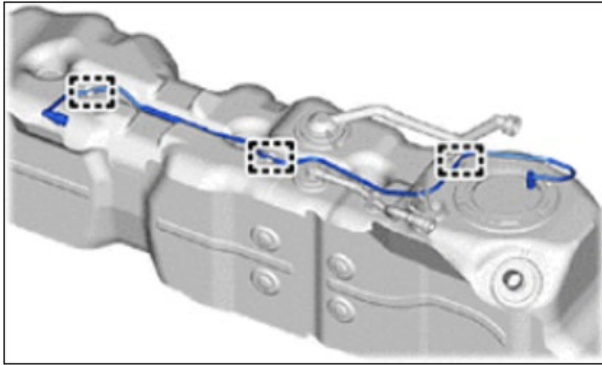

- b. Remove the fuel tube connection at the fuel sending unit.

**NOTE: Remove any foreign matter on the fuel tube connector and fuel pipe before performing this work.**

1. Pull out the retainer to detach the lock claws and pull off the fuel tube connector.
2. If the fuel tube connector and fuel pipe are stuck, push and pull the fuel tube connector to release it. Pull the fuel tube connector off the fuel pipe carefully.
3. Remove the fuel tube.
4. Remove any residual fuel from inside the tube before continuing.

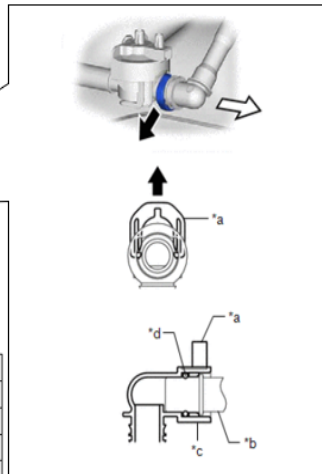

"a	Retainer
"b	Fuel Pipe
"c	Fuel Tube Connector
"d	O-ring
	Pull out
	Pull off

## 6. INSTALL **NEW** FUEL TUBE TO FUEL TANK

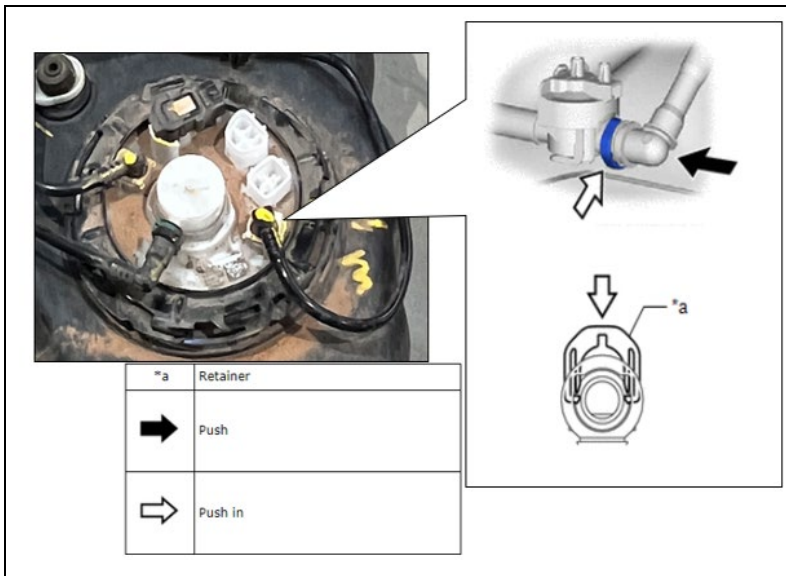

a. Install the fuel tube connection.

1. Align the fuel tube connector with the fuel pipe, push the fuel tube connector onto the fuel pipe, and then push in the retainer to secure the connection.

**NOTE:** Confirm that the retainer makes a "click" sound when pushed.

2. After connecting the fuel line, check that the fuel tube connector is securely connected by pulling on it.

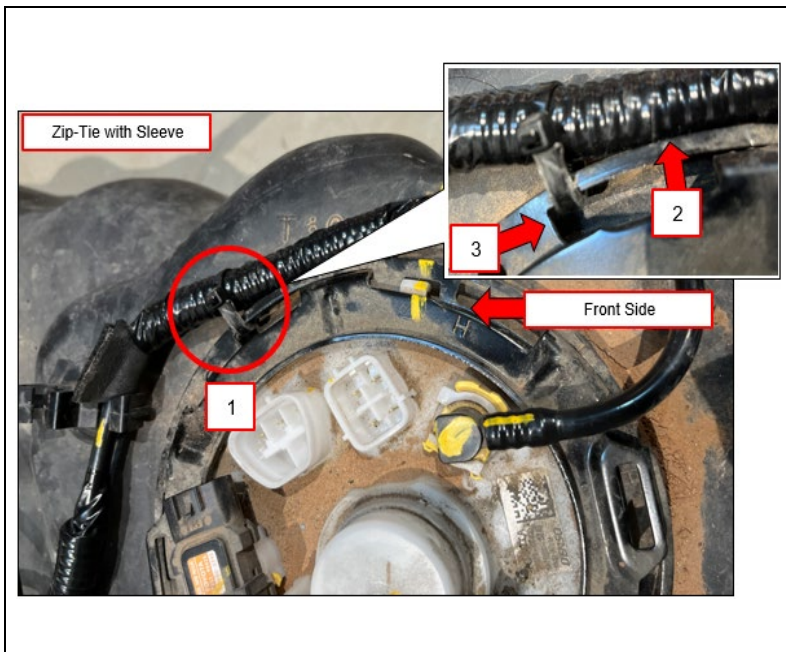

b. Install **ONLY** the Zip Tie to the fuel tube.

1. Secure the fuel tube to the fuel-sending unit using only the zip tie. The additional protective sleeve as seen in the photo is not required.
2. The zip tie must be installed so that there is no space between the tube and the sending unit bracket.
3. Be sure that the zip tie is installed in the frontmost position of the fuel sending unit bracket.

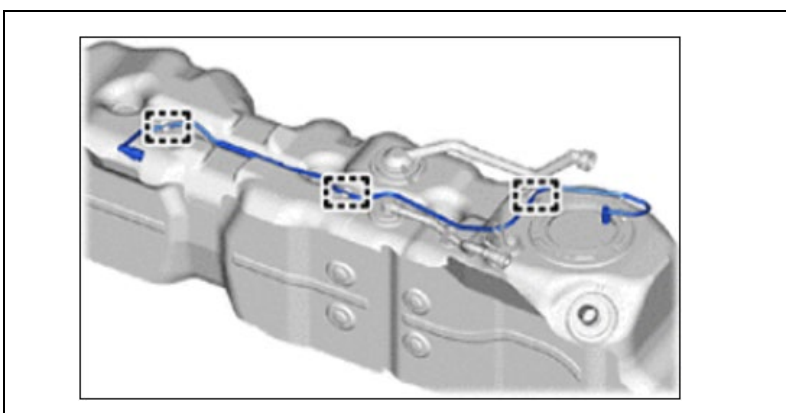

c. Install the fuel tube to the fuel tank clips.

1. Install the fuel tube to the three clips securing it to the fuel tank assembly.

## 7. RE-INSTALL FUEL TANK

- a. Install the fuel tank following the repair manual steps:
  - [V35A-FTS \(FUEL\): FUEL TANK: INSTALLATION; 2022 - 2024 MY Tundra Tundra HV](#)
- b. If fuel was removed from the tank prior to disassembly, reinstall the originally recovered fuel into the tank.



## 8. CHECK FOR DTCS

- a. Using Techstream, check for Diagnostic Trouble Codes.

**NOTE: This Safety Recall covers only the installation of the fuel line kit and associated parts. It does not cover the diagnosis or replacement of any other parts of the vehicle.**



**◀ VERIFY REPAIR QUALITY ▶**

- Confirm fuel line repair kit is installed exactly as instructed (if applicable).
- Confirm all fuel lines and electrical connectors are properly fastened.
- Confirm no fuel leaks are present after completing the repair.
- If you have any questions regarding this update, please contact your area representative.

## X. APPENDIX

### A. PARTS DISPOSAL

As required by Federal Regulations, please make sure all recalled parts (original parts) removed from the vehicle are disposed of in a manner in which they will not be reused, ***unless requested for parts recovery return.***

### B. CAMPAIGN DESIGNATION DECODER

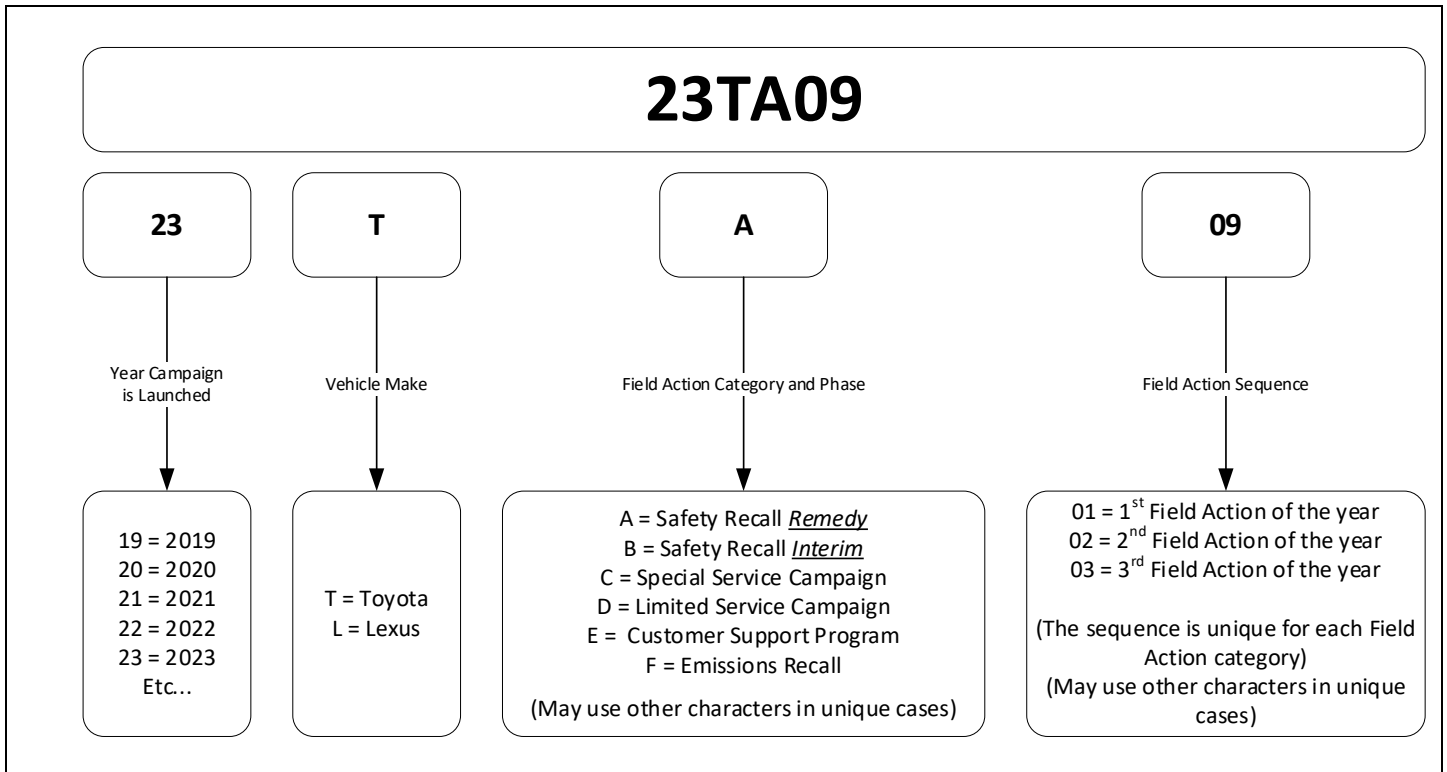

**Examples:**

**19TA01 = Launched in 2019, Toyota, Safety Recall Remedy Phase, 1st Safety Recall Launched in 2019**  
**20TC02 = Launched in 2020, Special Service Campaign, 2nd Special Service Campaign Launched in 2020**  
**21TE05 = Launched in 2021, Customer Support Program, 5th Customer Support Program Launched in 2021**