



GROUP	MODEL
Safety Recall Campaign	2017-2022MY Niro HEV (DE HEV) 2018 - 2022MY Niro PHEV (DE PHEV)
NUMBER	DATE
SC276	December 2023

SAFETY RECALL CAMPAIGN

ENGINE HCA INSPECTION AND FUUSE/HCA REPLACEMENT (SC276)

SUBJECT:

This bulletin provides information to inspect the engine Hydraulic Clutch Actuator (HCA) for a stored Diagnostic Trouble Code (DTC) and, if necessary, replace the HCA on certain 2017-2022MY Niro HEV (DE HEV) produced from November 1, 2016 through June 16, 2022, and 2018-2022MY Niro PHEV (DE PHEV) vehicles produced from September 26, 2017 through April 13, 2022. The printed circuit board (PCB) in the HCA of the subject vehicles may become contaminated with fluid. A fluid contaminated PCB may lead to an electrical short circuit, increasing the risk of an engine compartment fire while driving and injury. This bulletin also provides information to install a new HCA fuse with one of a different capacity to mitigate the potential risk of fire caused by an electrical short circuit.

Follow the procedure outlined in this publication to inspect and replace the HCA and wiring kit if necessary, and then to install a new HCA. This Technical Service Bulletin (TSB) will be updated with the parts (HCA & wiring kit and warranty information as soon as it is available so the recall can be completed on vehicles that have a related DTC stored. Before conducting the procedure, verify that the vehicle is included in the list of affected VINs.

DTC Descriptions:

Refer to page 2.

NOTICE

There is no charge to the vehicle owner for this repair. Under applicable law, you may not sell or otherwise deliver any affected vehicle until it has been repaired pursuant to the procedures set forth in this bulletin.

Repair status for a VIN is provided on KDealer+ (Service → Warranty Coverage → Warranty Coverage Inquiry → Campaign Information). Not completed Recall / Service Action reports are available on KDealer+ (Consumer Affairs → Not Completed Recall → Recall VIN → Select Report), which includes a list of affected vehicles.

Inspection Procedure:

- Using KDS, scan for the following stored DTC(s):

SC276 Related DTC(s):

U1010, U1011, P17EE, P17ED, P17E8, P17E2, P1744.

- If one or more of the related DTC(s) are stored (NG), proceed to the 'Replacement Procedure' (Fuse) on page 3, and 'Repair Procedure' (HCA Wiring Kit) on page 6.
- If NO related DTC(s) are stored (OK), proceed to the 'Replacement Procedure' (Fuse) on page 3.

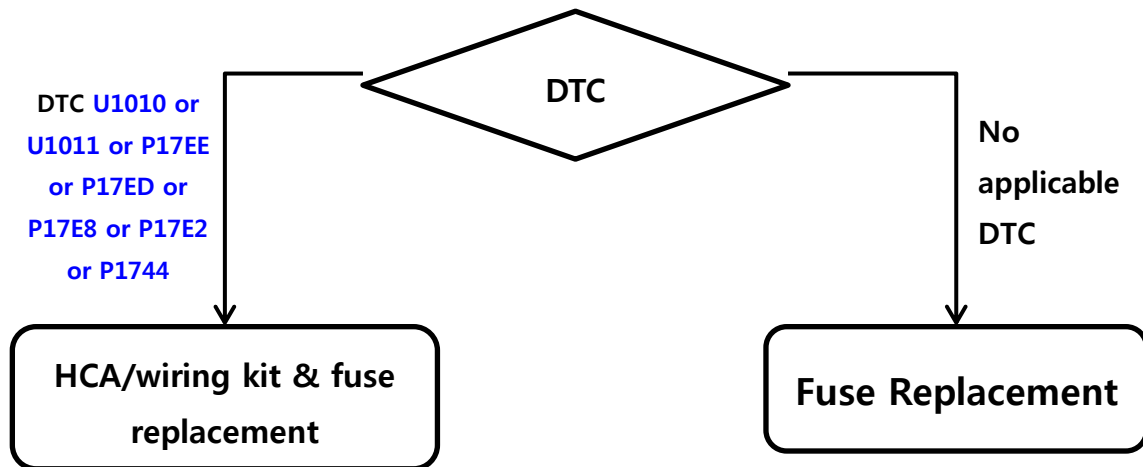
**DTC Descriptions:**

U1010 - CAN time out with HCU and HCA on local CAN
 U1011 - High voltage detected
 P17EE - Engine clutch system functional safety fault
 P17ED - Engine clutch system EOL fault
 P17E8 - Engine clutch system abnormal
 P17E2 - Engine clutch actuator electric hardware fault
 P1744 - Transmission engine clutch system performance

ⓘ IMPORTANT

***Vehicles requiring the 'HCU/Wiring Kit and Fuse' repair will need to be parked until this TSB is revised to include the complete Parts & Warranty Information. DO NOT attempt to complete the repair until this TSB is revised to include the missing information.**

SUBJECT:

ENGINE HCA INSPECTION AND FUSE/HCA REPLACEMENT (SC276)

Replacement Procedure: (Fuse)

1. Remove the luggage side cover in the trunk area and disconnect the battery (-) connector.



2. Open the hood and locate the junction box (A) and control harness connector (B).

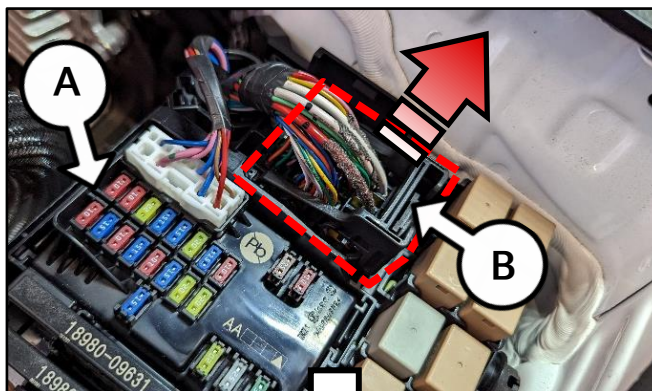

3. Detach/unlock the control harness connector (B) from the junction box.

4. Align the locking lever (C) release side marker tab(s) in the red circled area.

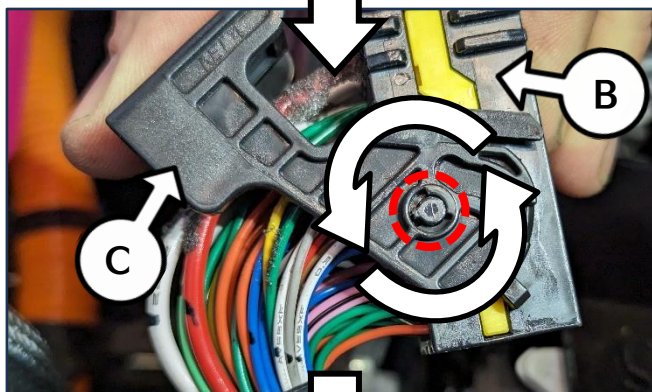

5. Once the 2 tabs are aligned, pull to release the locking lever (C) from both sides of the connector (B).

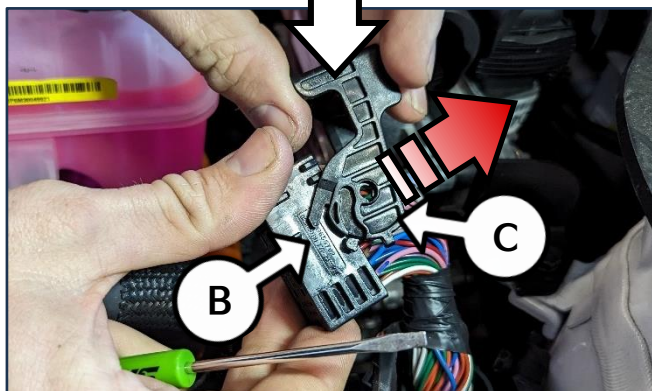

SUBJECT:

ENGINE HCA INSPECTION AND FUSE/HCA REPLACEMENT (SC276)

- Identify the No. 21 and No. 22 wires on the control harness connector (B).

Note: Front view of the connector is shown.

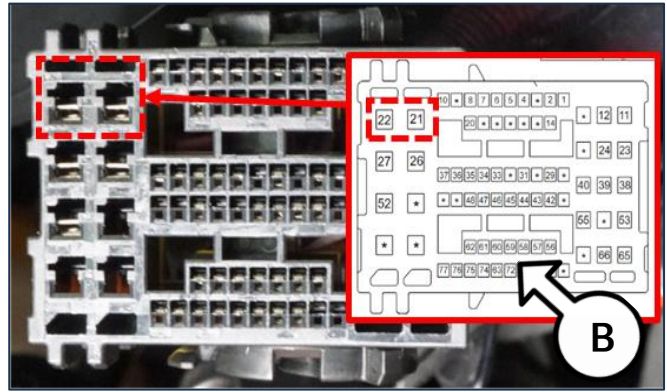

- Using a small screwdriver or connector pin remover, carefully release the connector (B) wiring locking tab (D) by lifting up in the area shown.

CAUTION

Apply gentle but firm force as to not damage the lock tab/connector/pins.

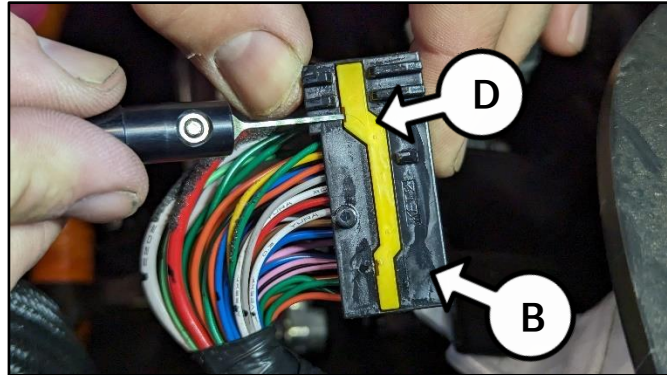

- Using a connector pin remover, release the No. 21 and No. 22 wires from the connector (B).

NOTICE

Before releasing the first wire, mark a line using a permanent marker to aid in identifying No. 21 vs. No. 22.

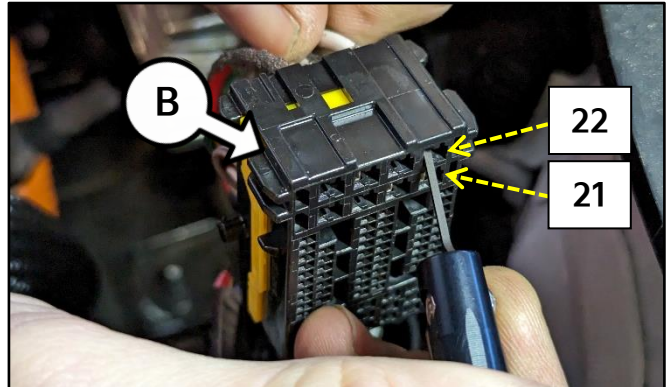

- Once both wires are released, switch the two (2) wires to their opposite location.

Note: Insert the removed No. 21 wire into the No. 22 connector slot and the removed No. 22 wire into the No. 21 connector slot.

- Reassemble the connector (B) in the reverse order of disassembly (steps 4-8).

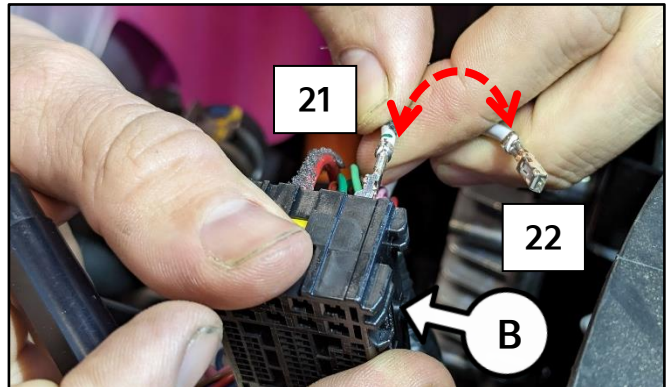

Replacement Procedure: (Engine HCA & Wiring Kit)

- 1a. Replace the engine hydraulic clutch actuator by referring to “Engine Clutch Assembly → Clutch System → Engine Clutch Actuator → Repair procedures” in the applicable Shop Manual on KGIS.

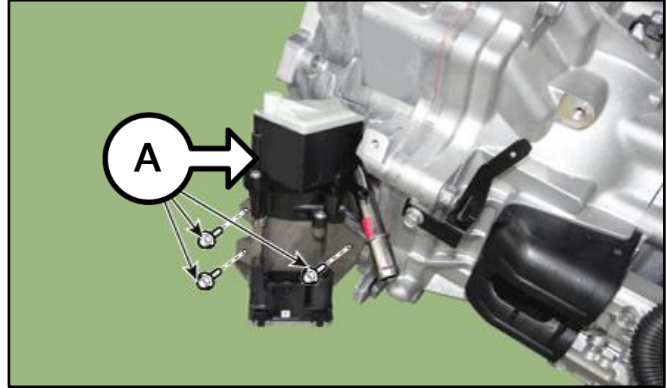

- Use SST OK253 R0100 or equivalent tool to help block the fluid from draining/leaking from the oil feed hose.

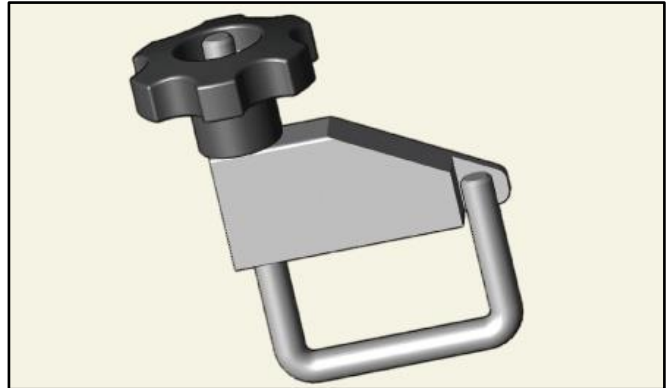

- 1b. BEFORE reconnecting the engine HCA connector (B) and performing the ‘Initialization of the engine clutch inspection line learning and diagnostic information’ installation procedure on KGIS, follow the proceeding steps to replace the engine HCA connector (B) wiring pigtail.

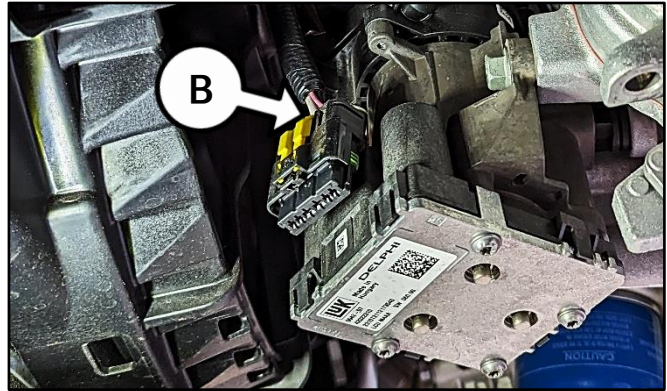

2. Remove the insulation/corrugate tubing (C) from the engine HCA connector (B) wiring.
3. Cut the connector wiring in the red dotted line area shown. (5 wires total).

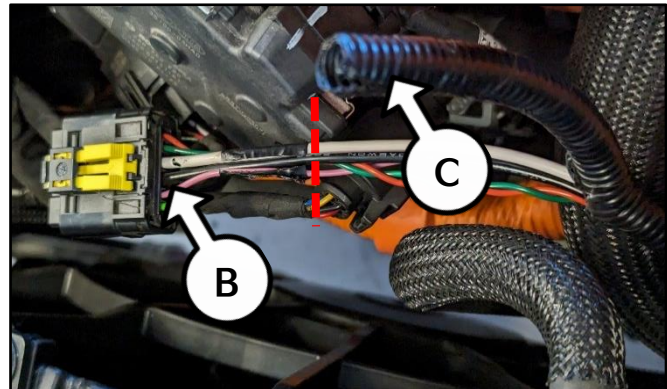

SUBJECT:

ENGINE HCA INSPECTION AND FUSE/HCA REPLACEMENT (SC276)

- Strip each of the engine HCA 5 wire ends on the vehicle wiring, as shown.



- Take the 'new' engine HCA connector pigtail, slide the provided heat shrink tube over one of the wires.

- Join the selected wire and match it to the vehicles wiring harness, as shown.

Note: The pink wire is shown for reference use.

Note: A 'Dual Clip Holding Hands' tool was used to help hold the wires together. (Locally sourced)

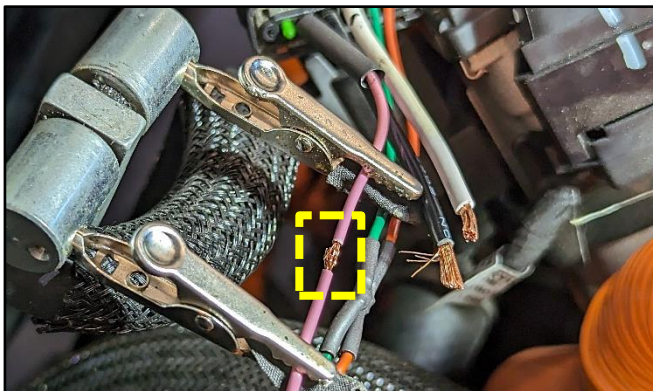

- Solder the wires together, as shown.

Note: Refer to 'Technical Basics' publication [TB023](#) on KGIS for soldering iron instructions.

- Repeat steps 5-7 for the remaining 4 wires.

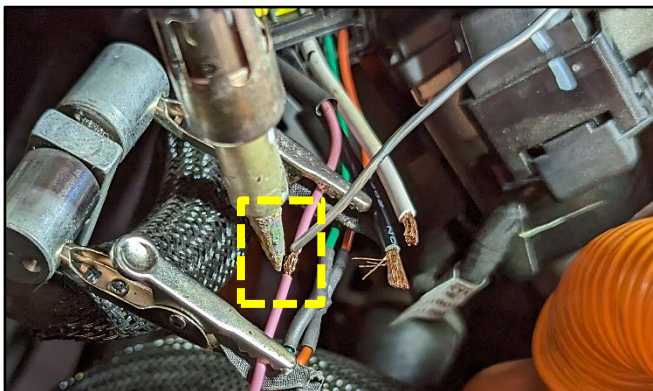

- Using a heat gun, apply heat to shrink the insulation tubing around the soldered wire area, as shown.

- Repeat step 9 for the remaining 4 wires.

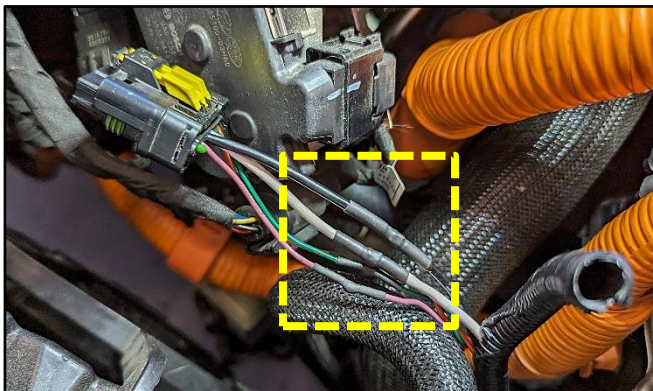

11. Install the provided 'new' insulation/corrugate tubing (C) over the work wiring area.
12. Adhere electrical tape over/around the corrugate tubing, as shown.

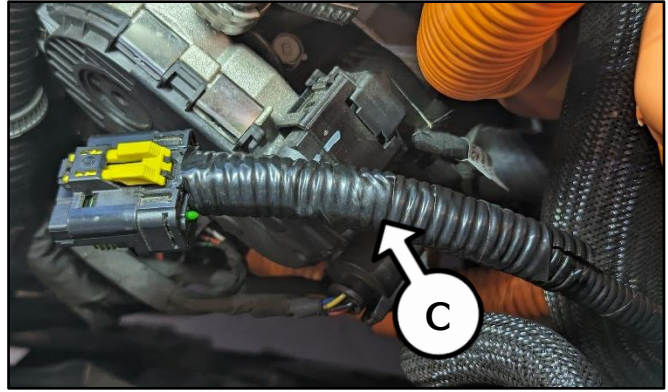

13. Connect the repaired connector (B) to the 'new' engine HCA.

Ensure to follow/complete the 'installation' instructions on KGIS for the engine HCA.

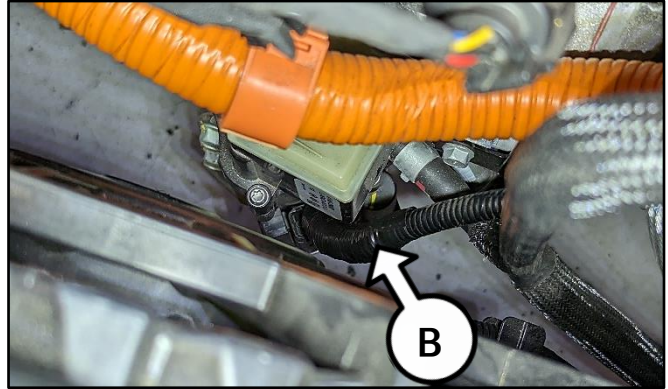

14. Reconnect the battery negative (-) cable.
15. Confirm normal vehicle operation.

SUBJECT:

ENGINE HCA INSPECTION AND FUSE/HCA REPLACEMENT (SC276)**AFFECTED VEHICLE RANGE:**



Model	Production Date Range
Niro HEV (DE HEV)	November 1, 2016 to June 16, 2022
Niro PHEV (DE PHEV)	September 26, 2017 to April 13, 2022

REQUIRED TOOL:

Tool Name	Part Number	Figure	Comments
KDS			

Refer to Technical Basics publication [TB023](#) 'How to Use a Soldering Iron'

REQUIRED PART:

Part Name	Part Number	Figure	Qty.
15A Fuse Kit	91400 DE200QQK		1
HCA Assembly + HCA Wiring Kit	TBD		1

WARRANTY INFORMATION:

N Code: N99 C Code: C99

Claim Type	Causal P/N	Qty.	Repair Description	Labor Op Code	Op Time	Replacement P/N	Qty.
R	41470 2B010	0	(SC276) HCA DTC Inspection+ HCA/Wiring Kit Replacement+ Fuse & Label Installation	TBD	N/A	TBD	1
			HCA DTC Inspection+ Fuse & Label Installation	230125R1	0.3 M/H	91400 DE200QQK	1

Refer to Warranty Bulletin 2023-39 for claim submission procedures. **The Technical Service Bulletin (TSB) will be updated with parts and claim information for 'HCA/Wiring Kit Replacement+Fuse/Label Installation' as soon as it is available.** When necessary, manually enter sublet code 'X2' for reimbursement of one roundtrip rideshare expense or up to three (3) days of rental for high pressure fuel pump replacement claims (only). All extended rental claims due to part backorder concerns must be substantiated with supporting documentation.

NOTICE

VIN inquiry data for this repair is provided for tracking purposes only. Kia retailers should reference **SC276** when accessing the KDealer+ system.

