

# Safety Recall Mack Trucks Inc.

Greensboro, NC USA



---

Release Date	Number	Release
10.2023	SC0447	01

## Akasol Battery LRBe

### RECALL INFORMATION

Mack trucks has determined that certain LRBe model vehicles may have been built with defective ESS battery packs. On affected vehicles, the rivnut inserts within the battery packs may have been over tightened and could fail. A failed rivnut insert has the potential of causing a short inside the battery pack which could lead to a battery fire.

Mack Trucks has not received any complaints or reports of vehicle crashes because of this safety issue; therefore, Mack considers this as a proactive measure to protect the public and Mack's customers from the potential risk associated with this defect.

To ensure that these vehicles meet Mack's stringent quality requirements, all affected ESS battery packs will require replacement by a certified Mack BEV dealer.

Please follow the procedures below to complete ESS battery replacement.

### VEHICLES AFFECTED

Certain 2022 to 2023 Mack LR Electric vehicles manufactured November 16, 2021 through January 04, 2023.

### VEHICLE QUANTITY

There are 15 vehicles affected by this recall (12 U.S, 3 Canada).

### Ordering instructions

Replacement batteries will need to be ordered using the VOR process. Please see details below.

- One VOR order per truck, that includes the full quantity of ESS battery packs needed to complete the recall repair (Most trucks will require 4 replacement batteries).
- If your facility has multiple truck in need of repair, please place a VOR order for each individual truck.
- When possible, please place battery orders one week in advance.
- For dealers that will be repairing a high volume of trucks, please determine your estimated battery consumption per week. For optimized shipping 24 battery packs can shipped per truck load.

### Parts

Part Number	Part Description	Quantity
24203806	Battery	4

 **DANGER**

**Risk of personal injury and environmental damage**

Internal or external damage to the traction battery can lead to thermal runaway, resulting in fire and/or explosion. If this occurs, toxic gases will leak from the battery.

- ▶ Handle the traction battery with care.
- ▶ Never expose the traction battery to a temperature higher than:

Tech data
70 °C (158 °F)

- ▶ In case of a strong sweet smell, heat, smoke or fire, in or near the traction battery: Warn others, evacuate the workshop, and stay away. Alert emergency service personnel.

 **DANGER**

**Risk of electrical discharge.**

Damaged traction voltage cables can cause electric shocks and arcs resulting in serious burns or death.

- ▶ Check that the traction voltage cables are in good condition before any operation is carried out.
- ▶ Report to the responsible person if any damaged traction voltage cables are found.

 **DANGER**

**Risk of electrical discharge.**

Incorrect handling of the traction voltage system (>60V DC or >30V AC) can cause electric shocks and arcs resulting in serious burns or death.

- ▶ Decommissioning and commissioning must only be carried out by personnel with adequate certification according to **Safety regulations, electric vehicles**, in function group 30.
- ▶ The steps described in the instruction are minimum requirements.
- ▶ Always comply with the local legislation or regulations with stricter safety requirements, including but not limited to, measuring tools and personal protective equipment to be used.

 **WARNING**

**Risk of burn injuries.**

The coolant may be hot.

- ▶ The cooling system is under pressure and can reach the temperature sufficient to cause burns. Allow the coolant temperature to reach the safe level before starting the work.
  - ▶ Remove the coolant tank cap carefully. Use appropriate protective equipment.

**ESS Battery Replacement Instructions**

1. Follow Impact Operation 3100-09-01-04 Traction Voltage System

Decommissioning.

2. Remove the screws.
3. Remove the shield

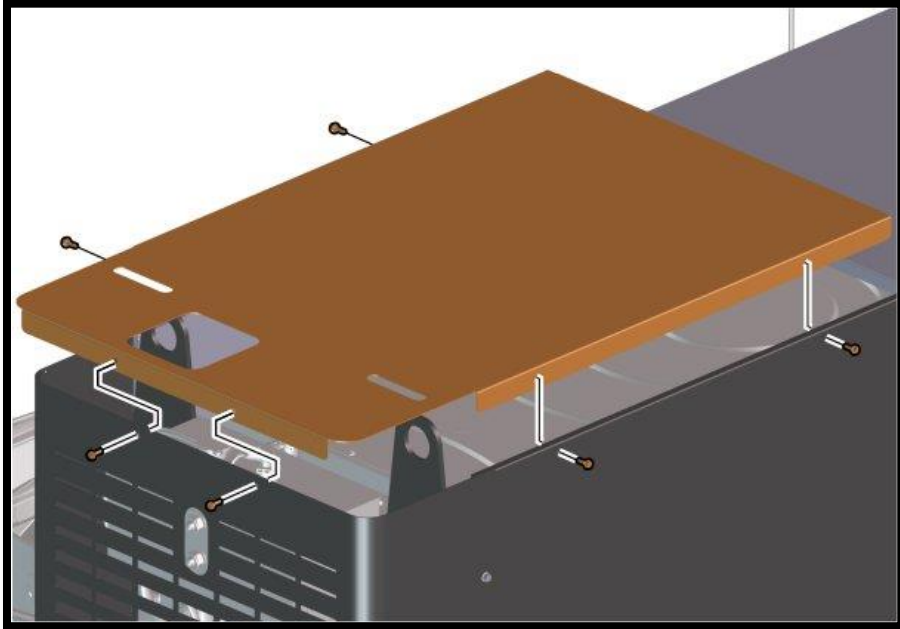

4. Remove the cap.

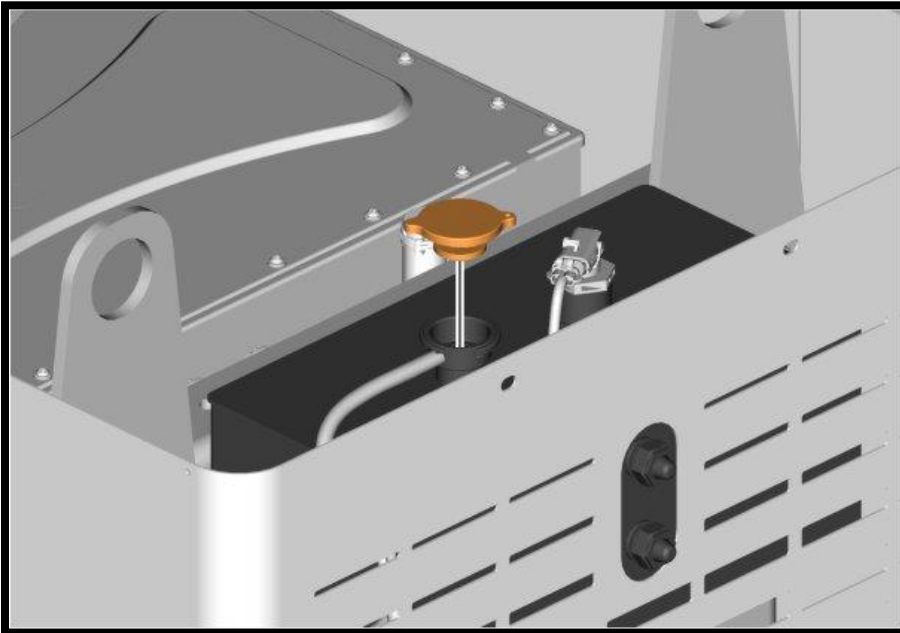

5. Position a draining container.
6. Clean the surrounding area.

7. Remove the plug.

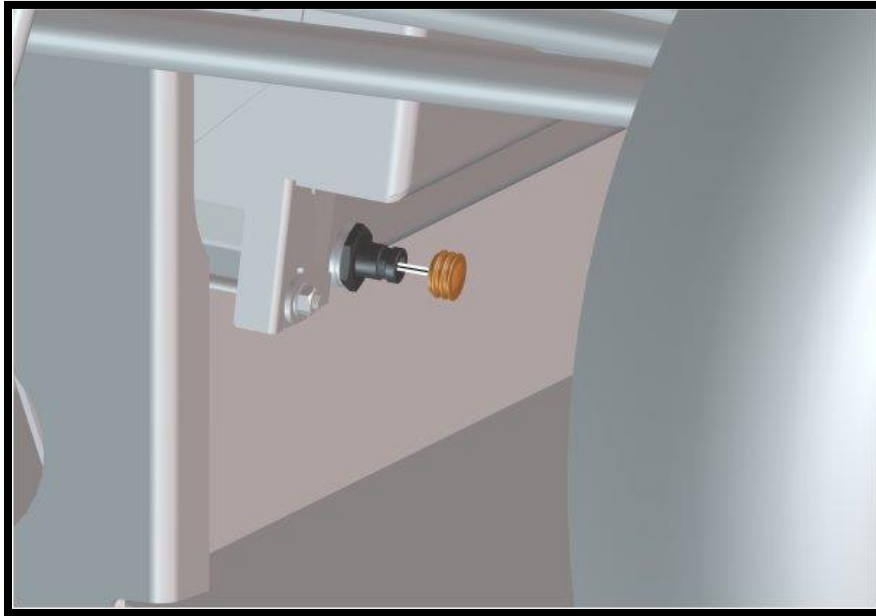

8. Drain the cooling system using either a coolant extractor or a drain hose and pan.

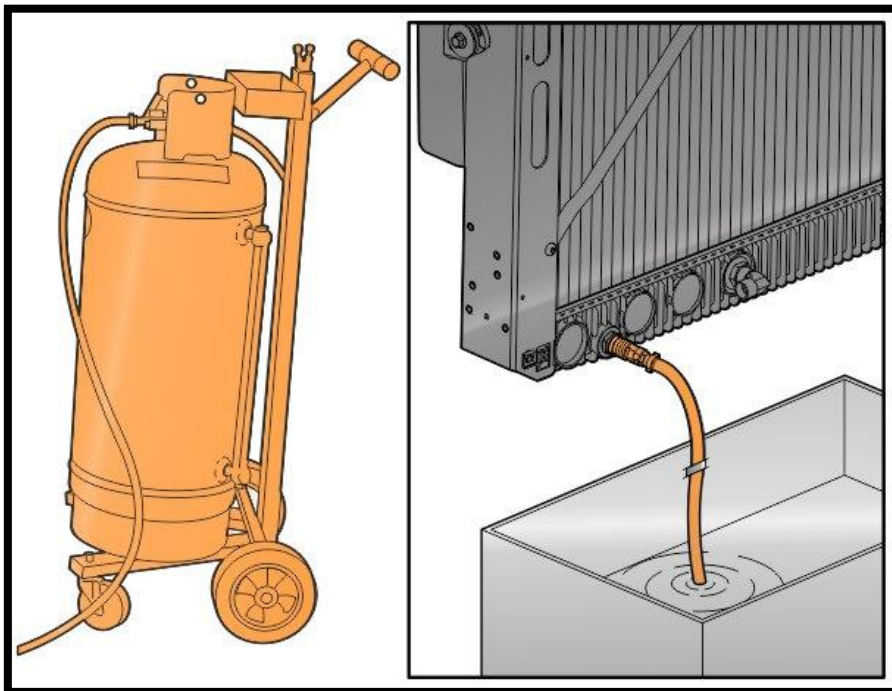

9. Install the plug.

10. Clean the area.

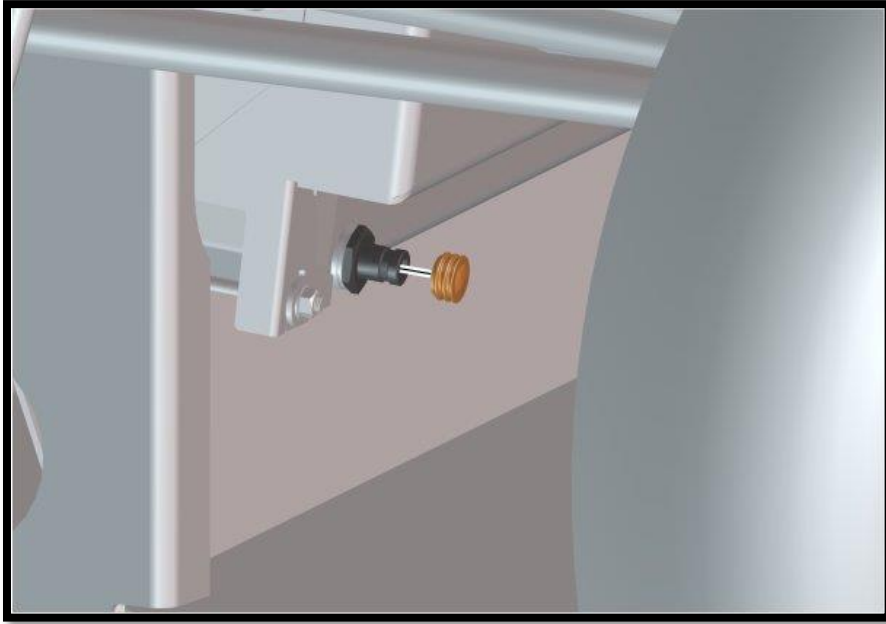

11. Remove the screws.

12. Remove the shield.

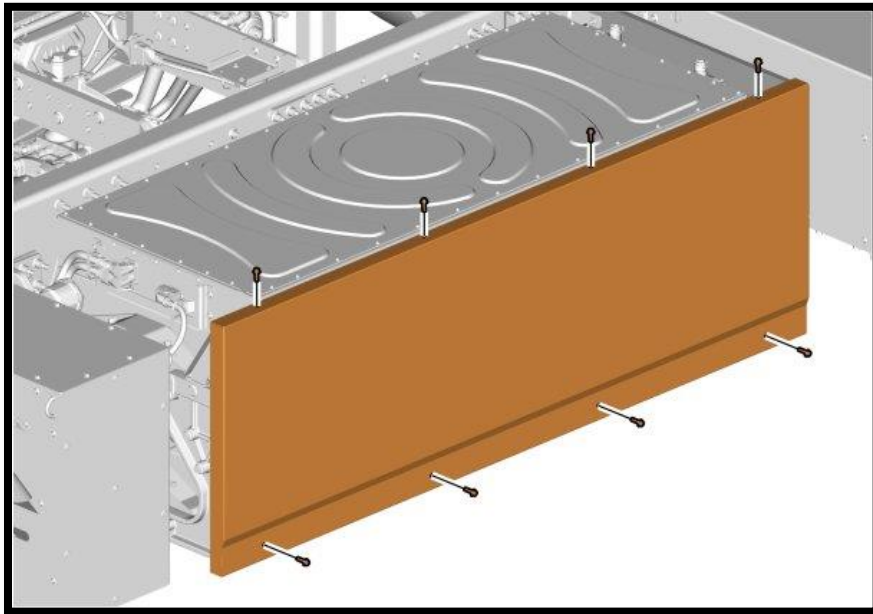

13. Remove the nut and the screws.

14. Remove the screws.

15. Remove the shield.

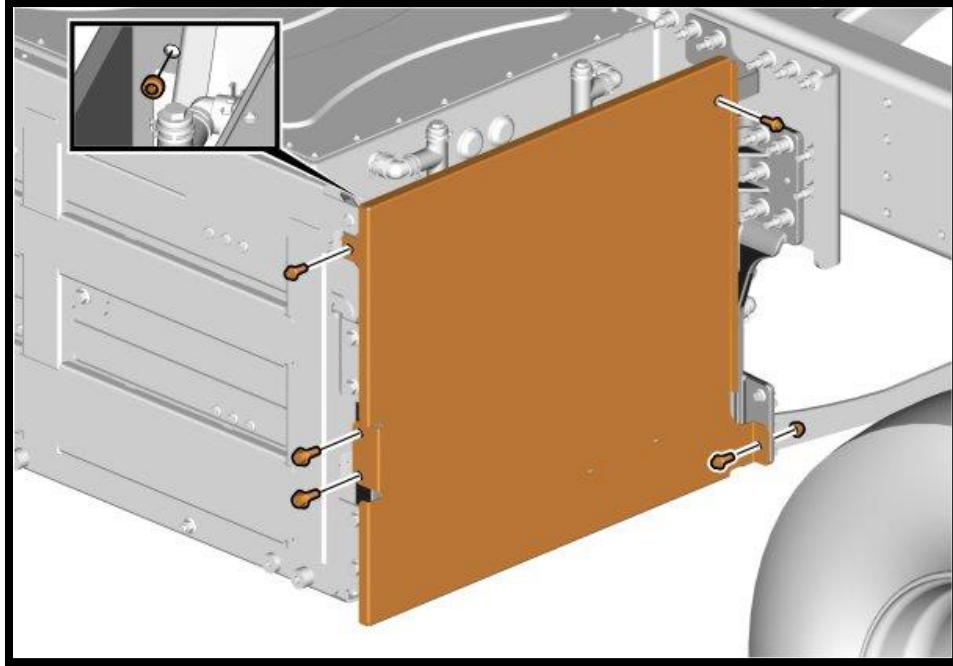

16. Position the draining container.

17. Remove the plugs.

18. Drain the coolant.

19. Install the plugs.

20. Clean the area.

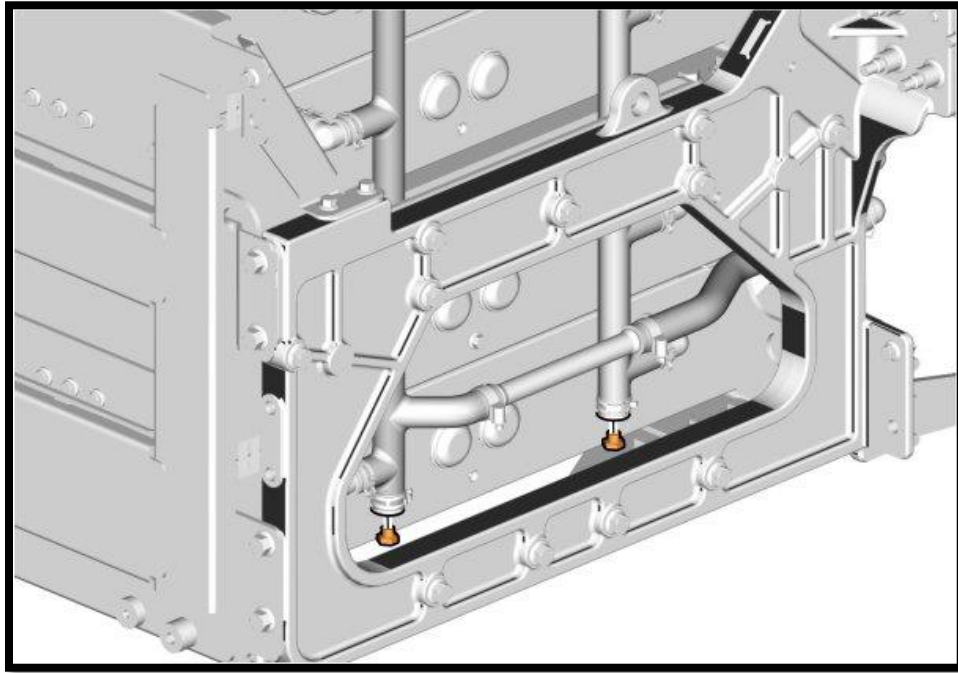

21. Remove the screws.

22. Remove the shield.

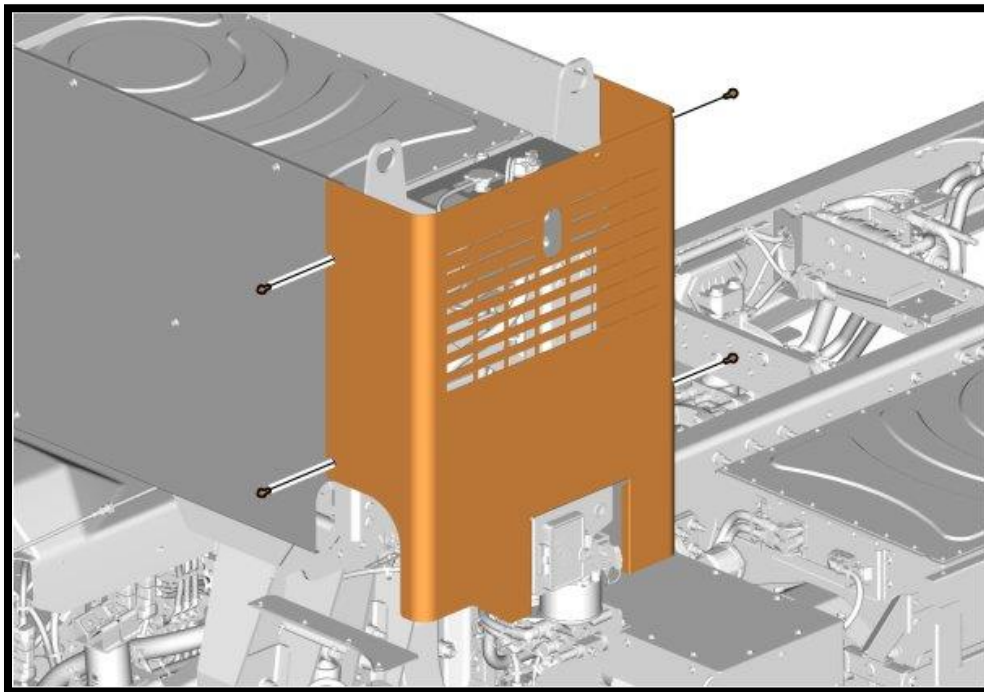

23. Position the draining container.



24. Remove the plugs.

25. Drain the coolant.

26. Install the plugs.

27. Clean the area.

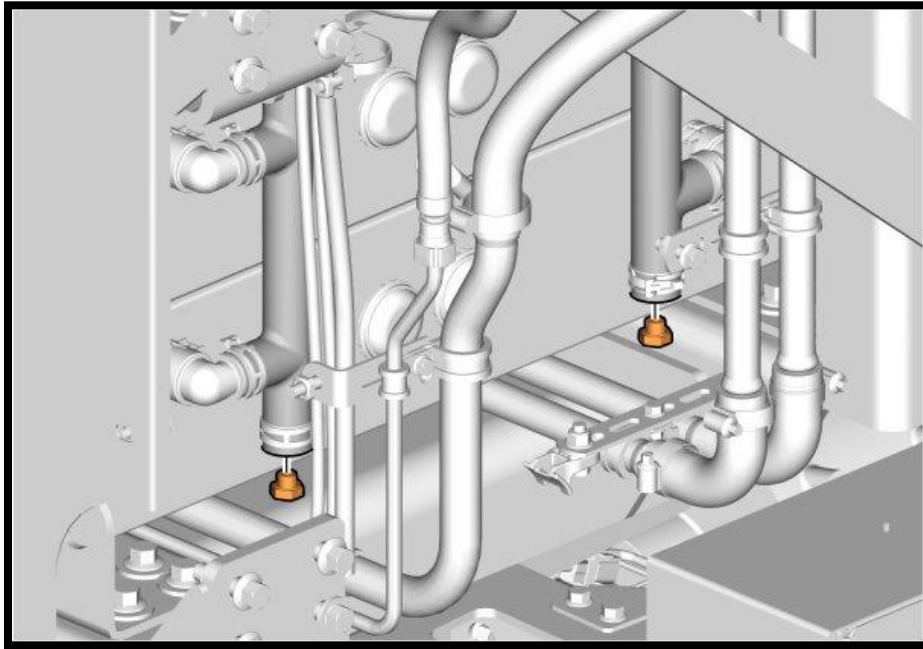

28. Remove the screws.

29. Remove the ESS protection frame.

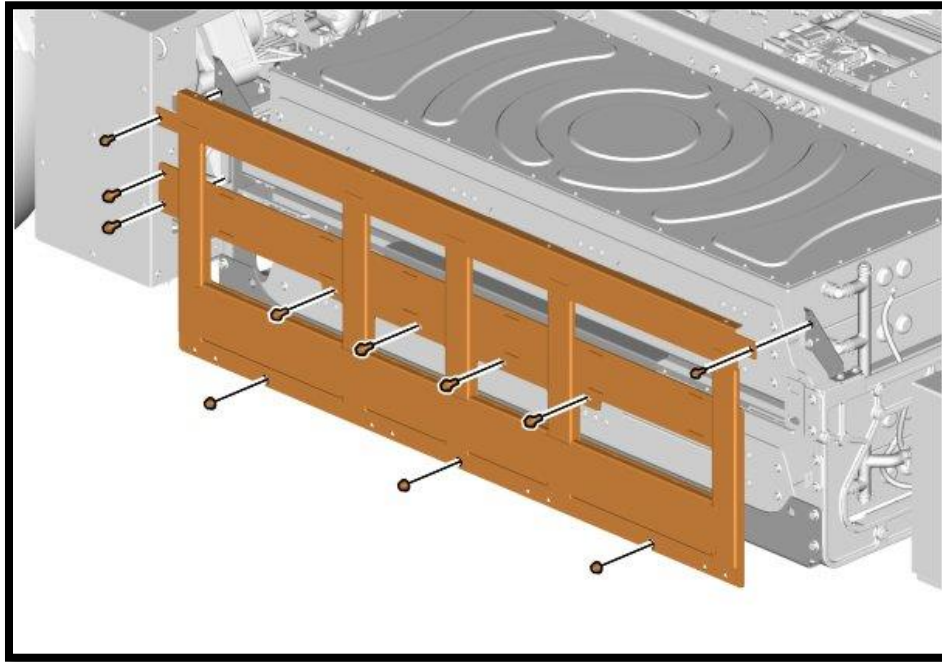

30. Remove the cable ties.

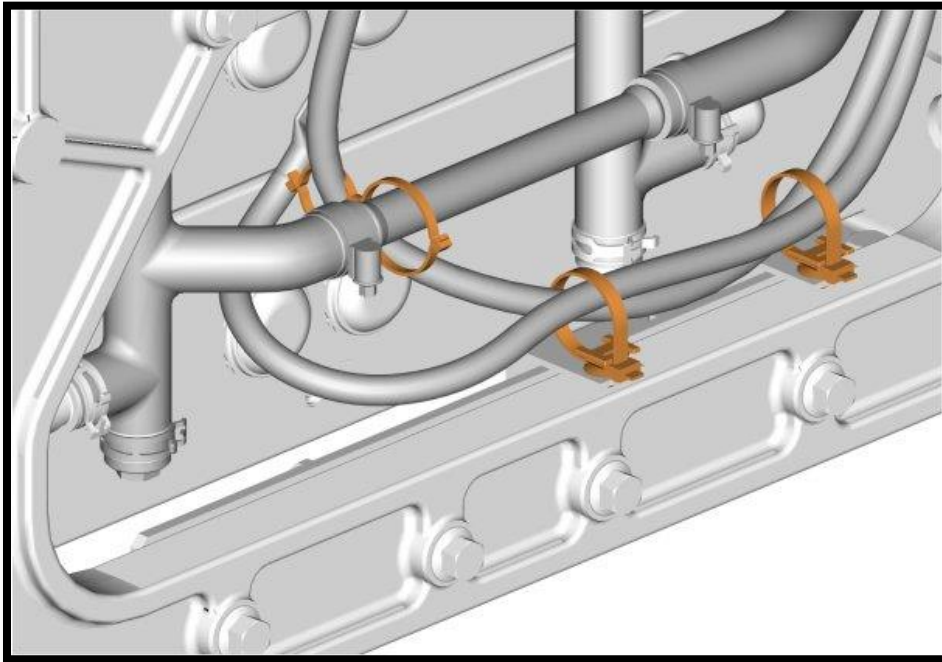

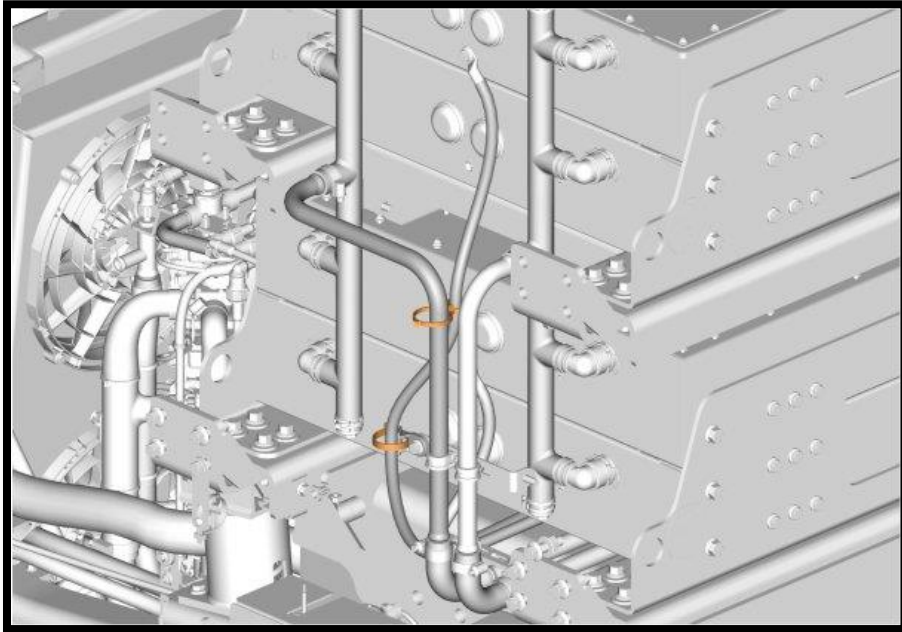

31. Remove the screws.

32. Remove the shield.

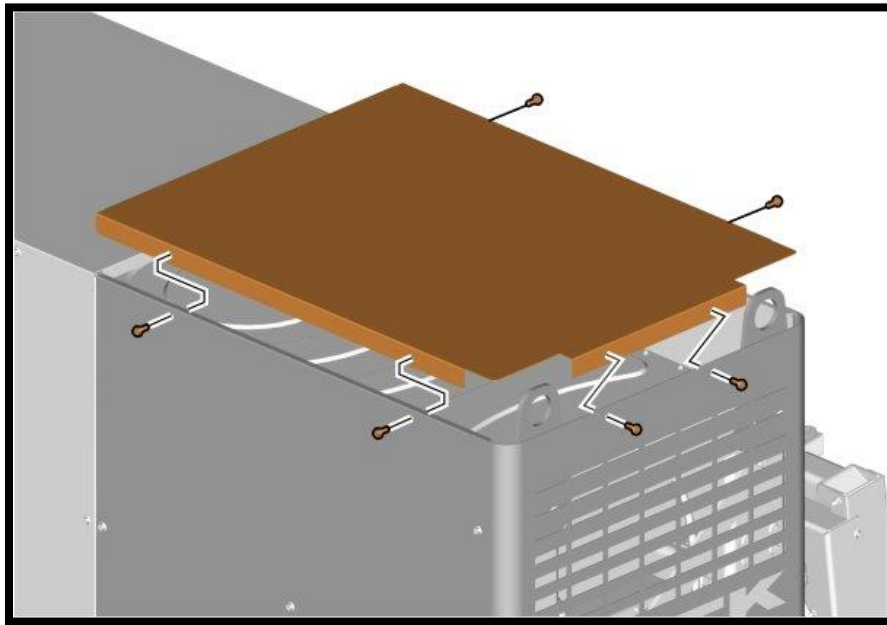

33. Remove the screws.

34. Remove the shield.

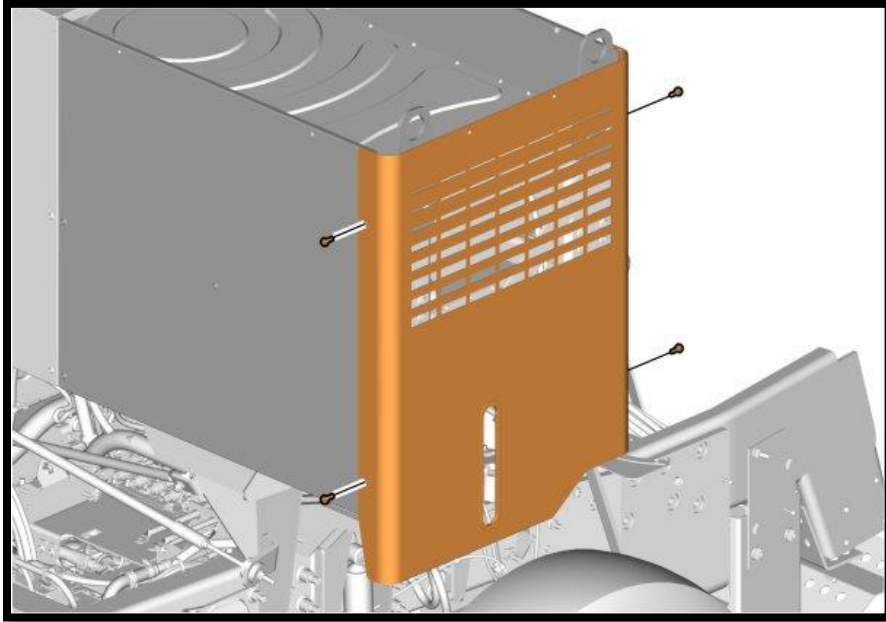

35. Remove the screws.

36. Remove the shield.

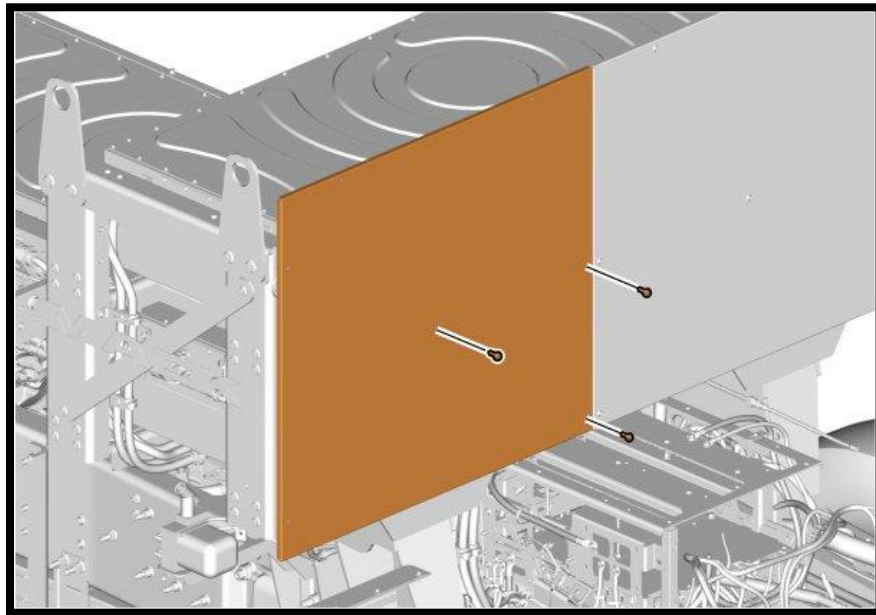

37. Remove the screws.

38. Remove the shield.

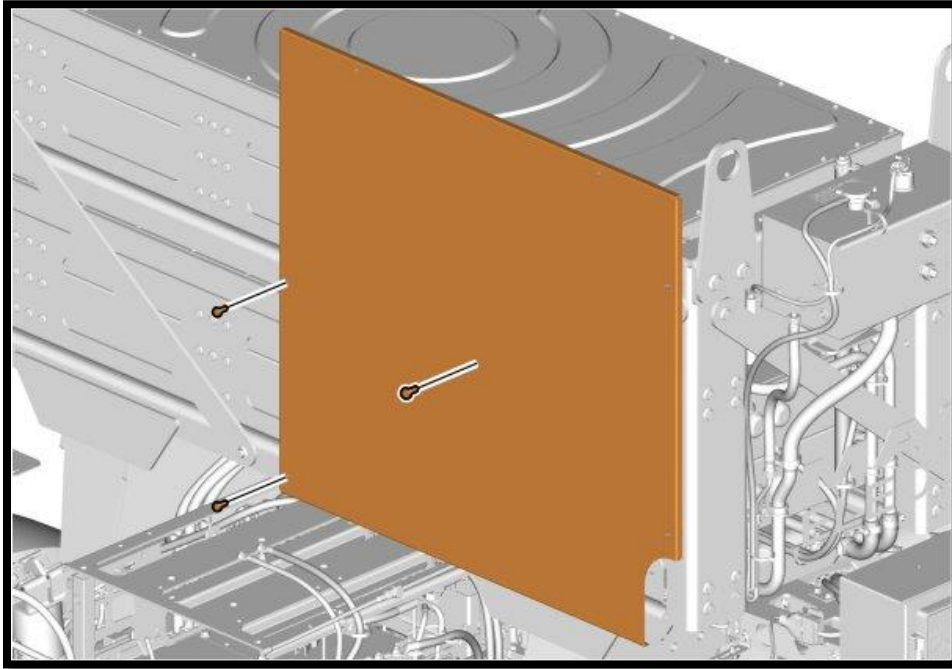

39. Remove the screws.

40. Remove the shield.

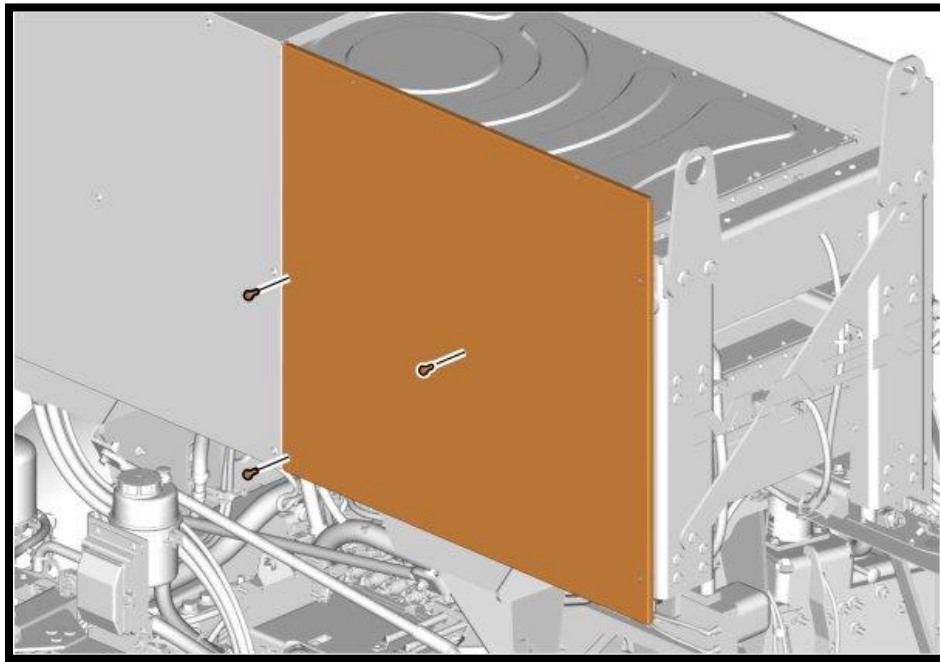

41. Remove the screws.

42. Remove the shield.

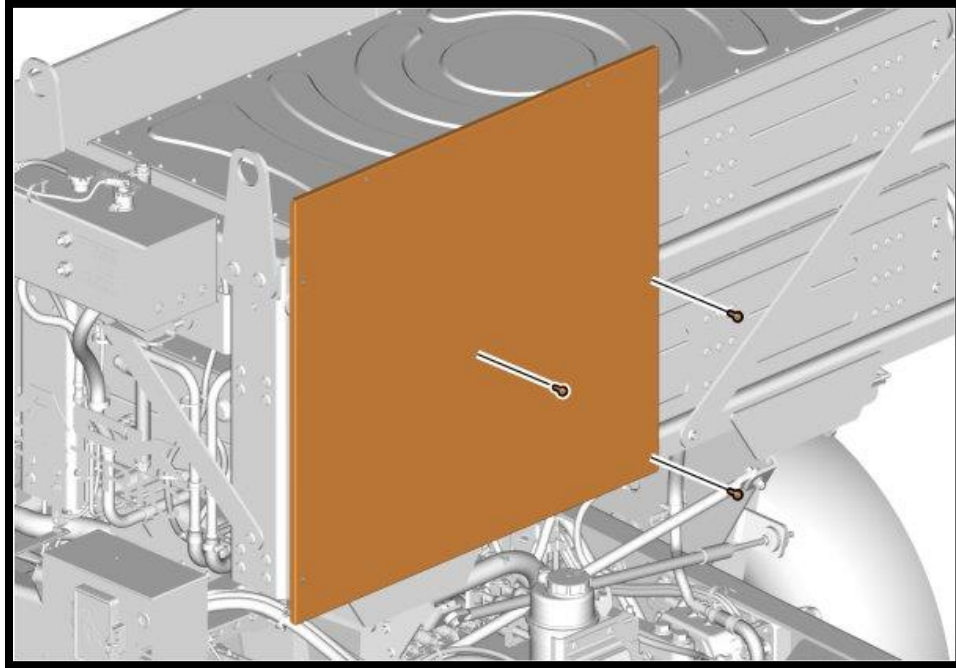

43. Remove the nuts and the screws.

44. Remove the braces.

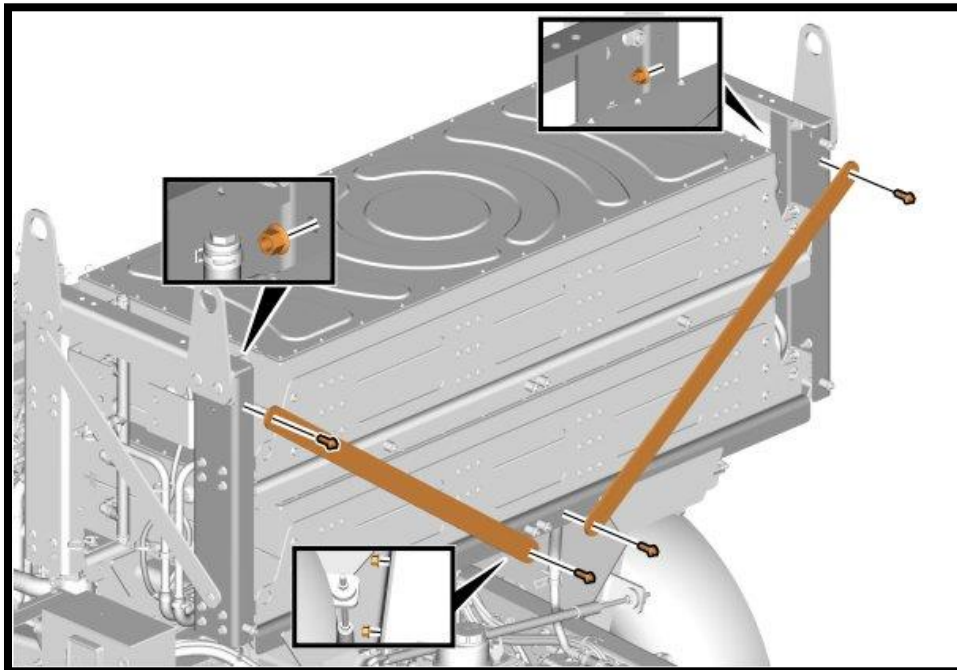

45. Remove the nuts and the screws.

46. Remove the braces.

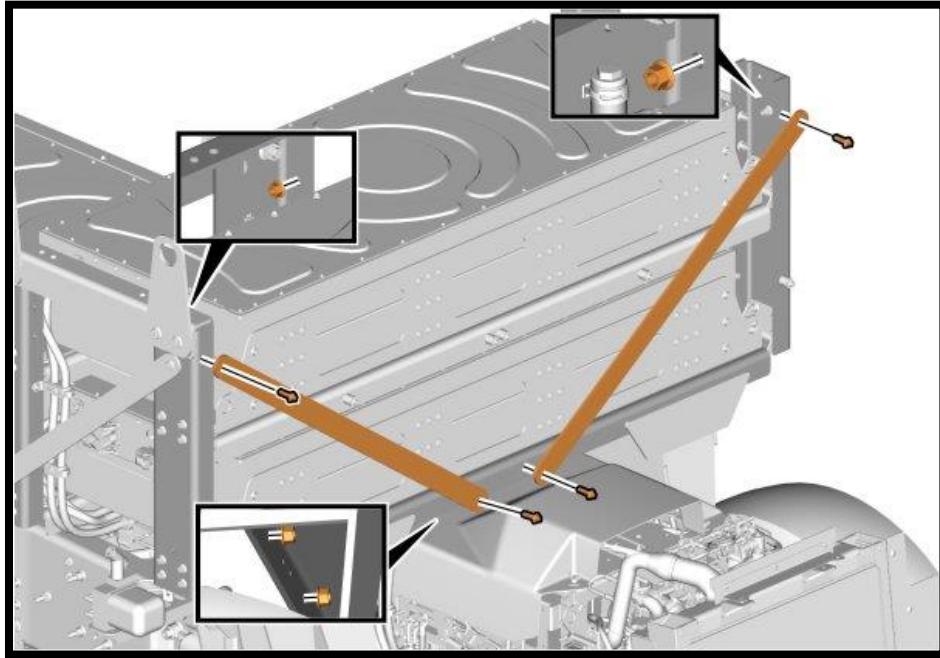

47. Loosen clamp.

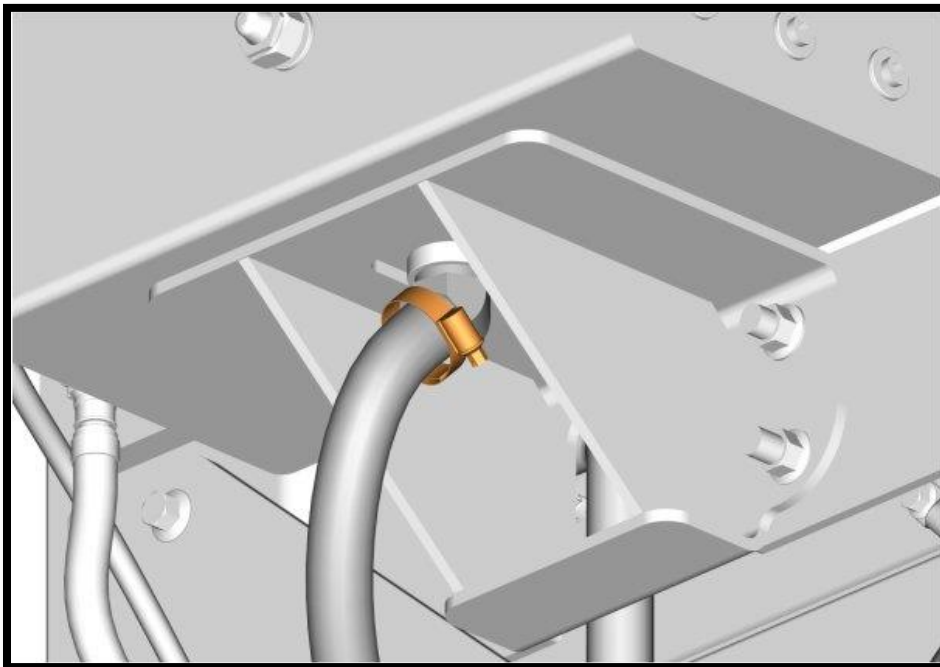

48. Move aside the hose.

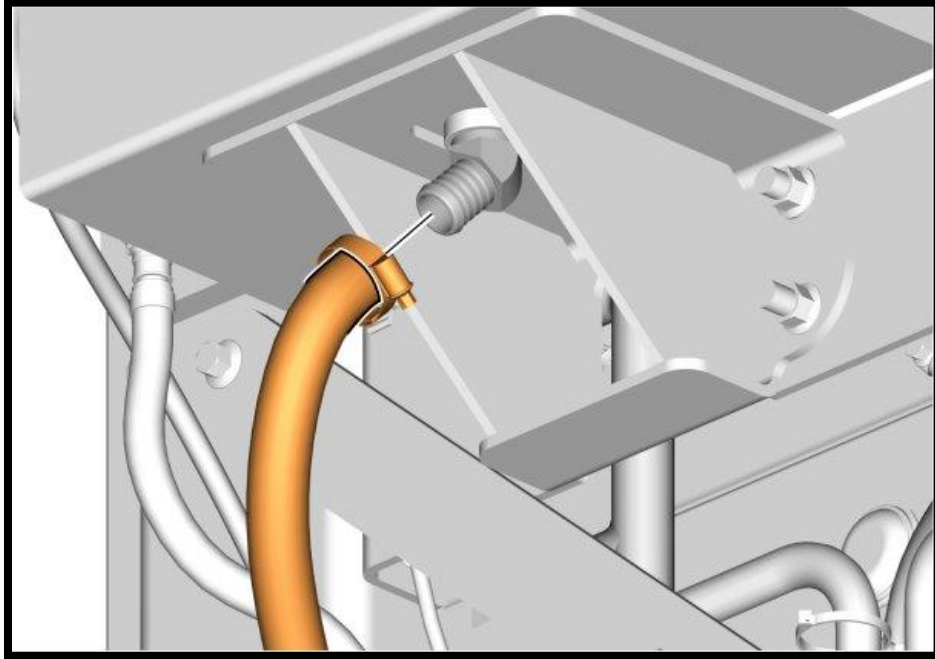

49. Remove the cable ties.

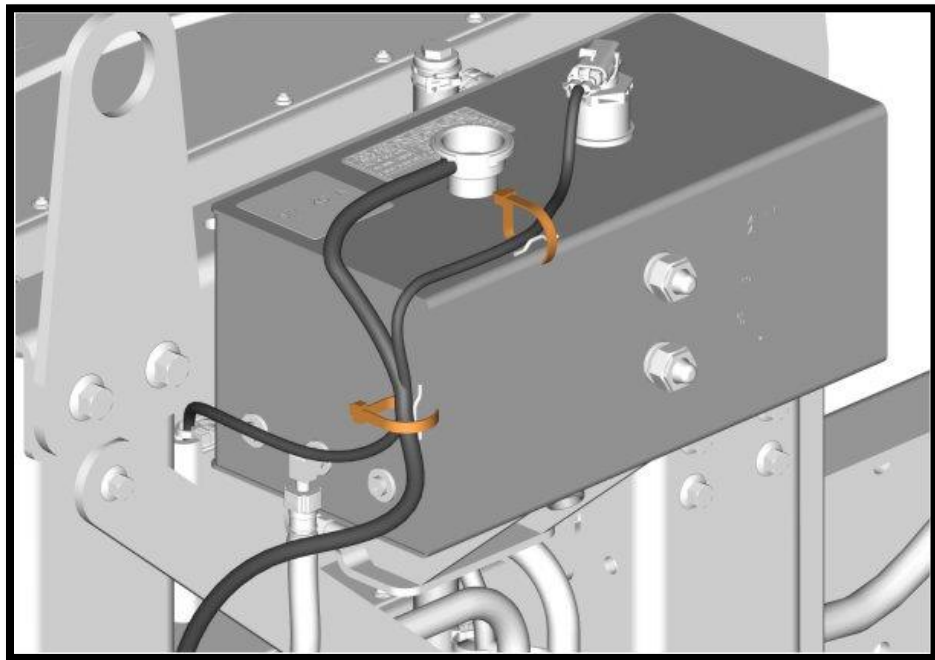

50. Disconnect the connector.



51. Move aside the hose.

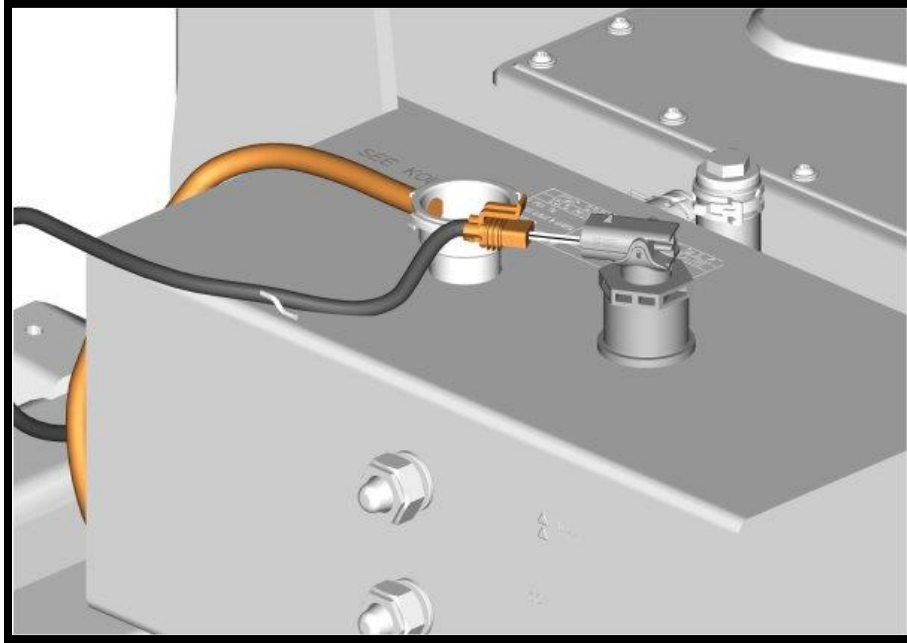

52. Remove the hose.

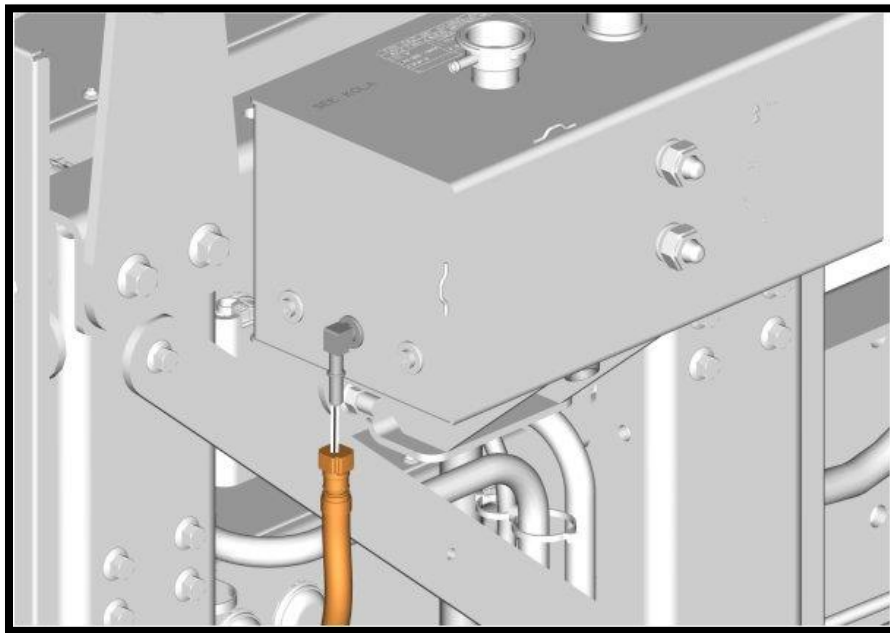

53. Remove the screw.

54. Move aside the cable.

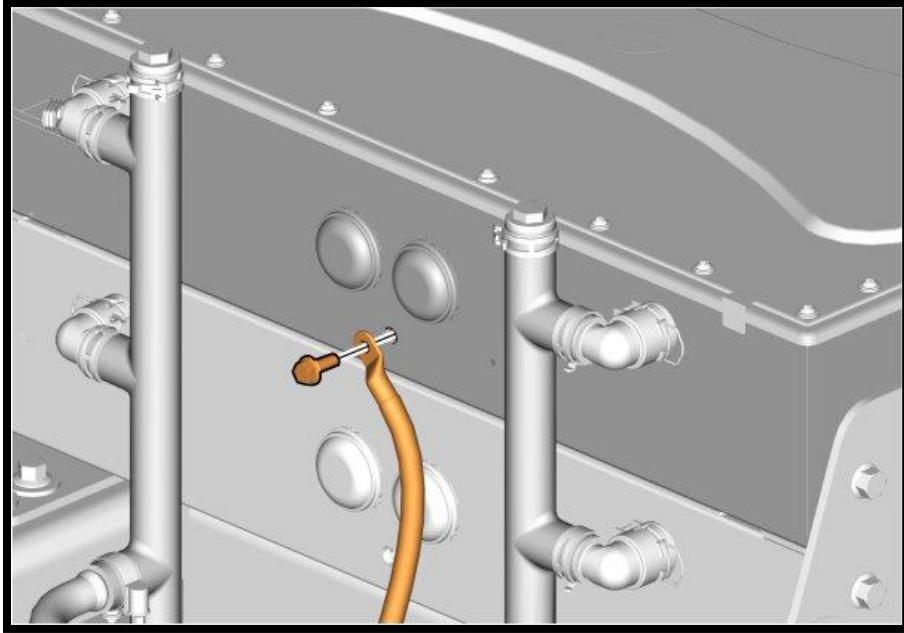

55. Remove the screw.

56. Move aside the cable.

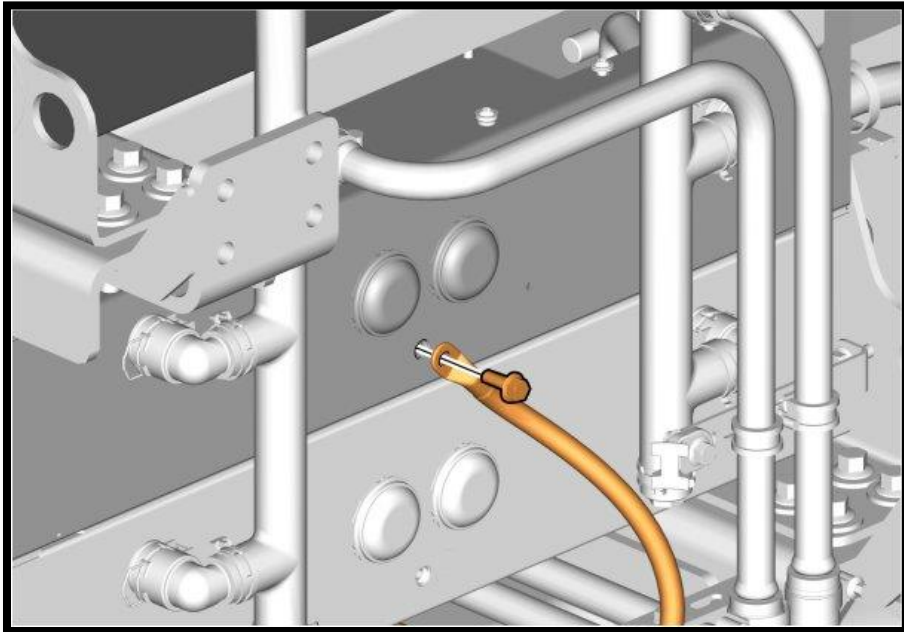

57. Remove the screw.

58. Move aside the cable.

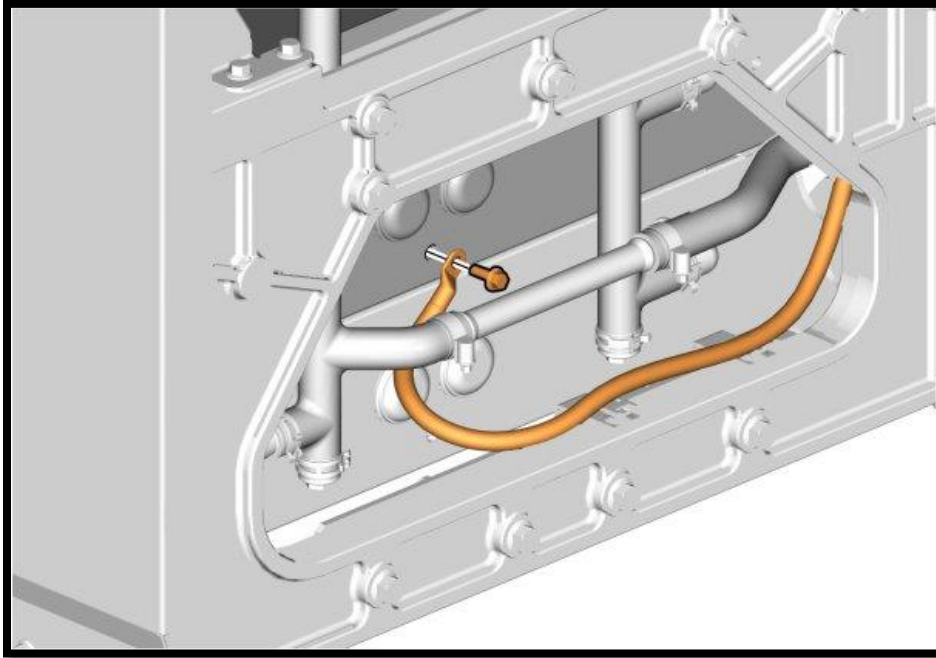

59. Remove the hoses.

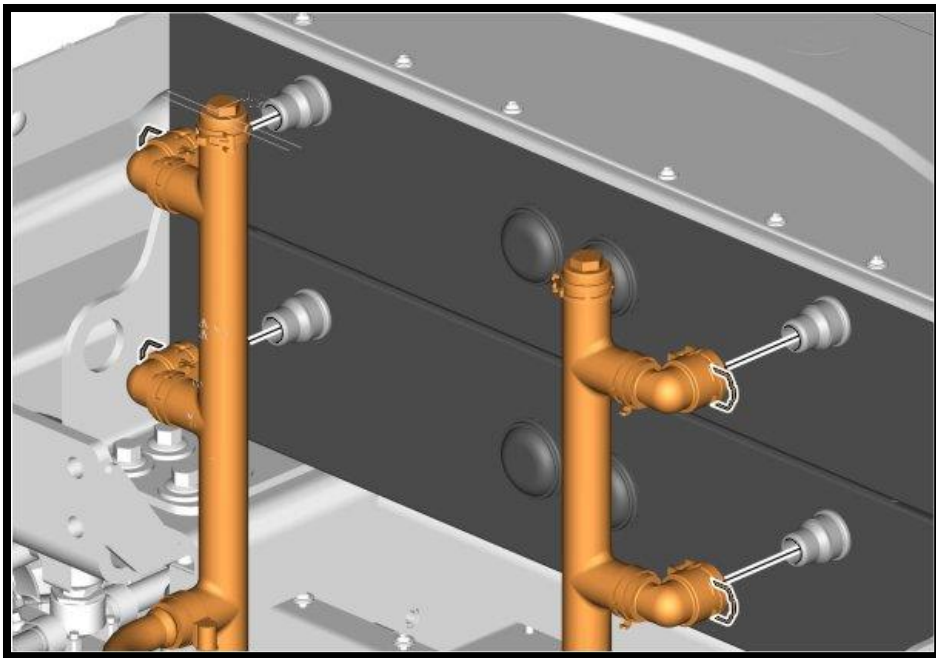

60. Remove the hoses.

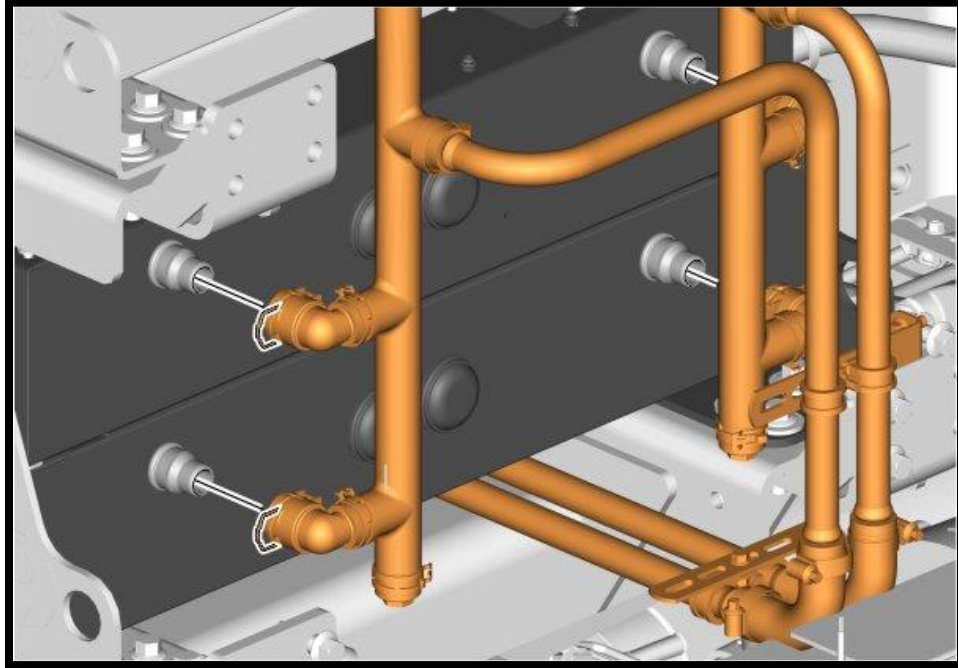

61. Remove the hoses.

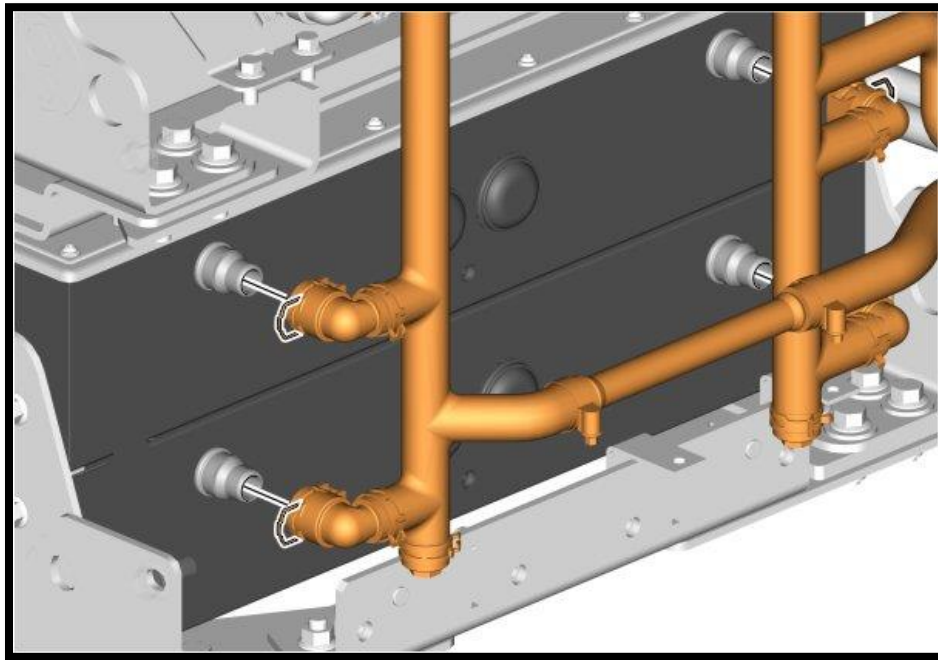

62. Support the ESS.

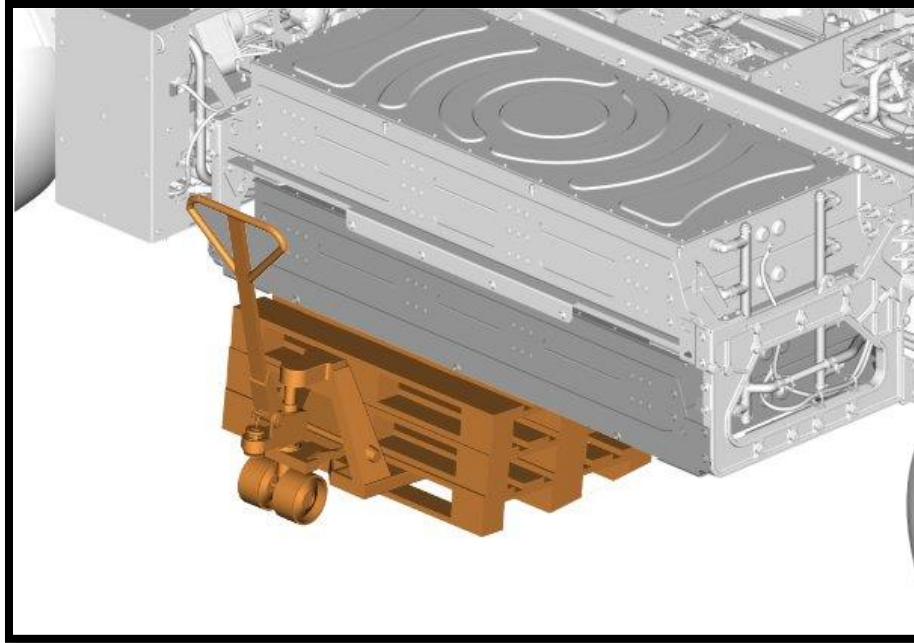

63. Remove the screws.

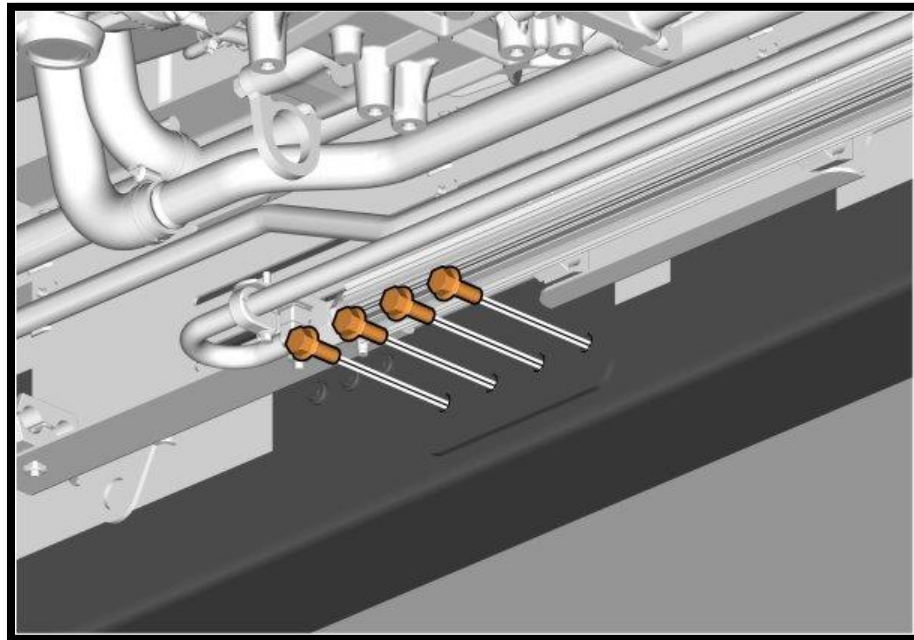

64. Remove the screws.

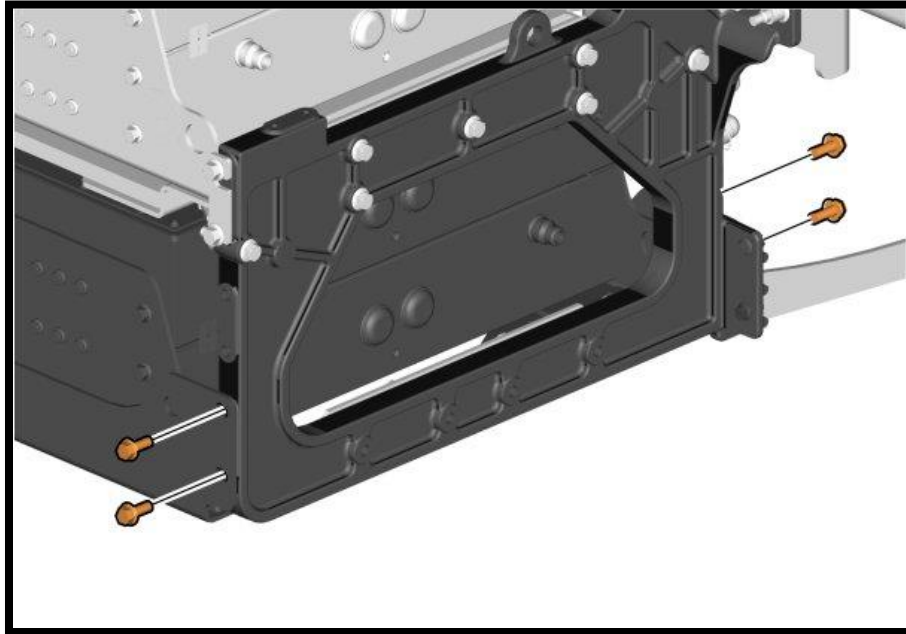

65. Perform the same operation on the other side.

66. Remove the nuts and the screws.

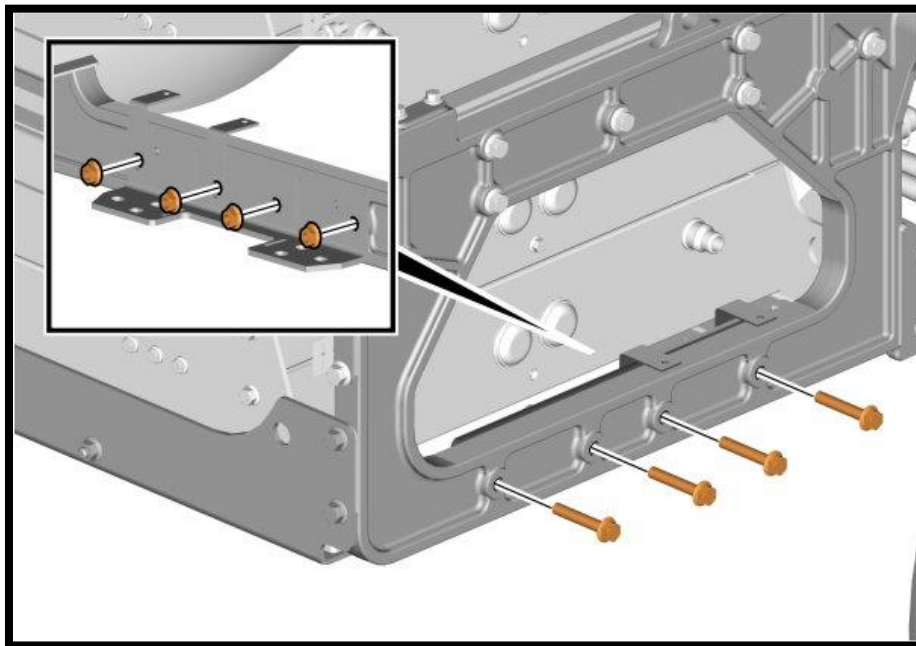

67. Remove the nuts and the screws.

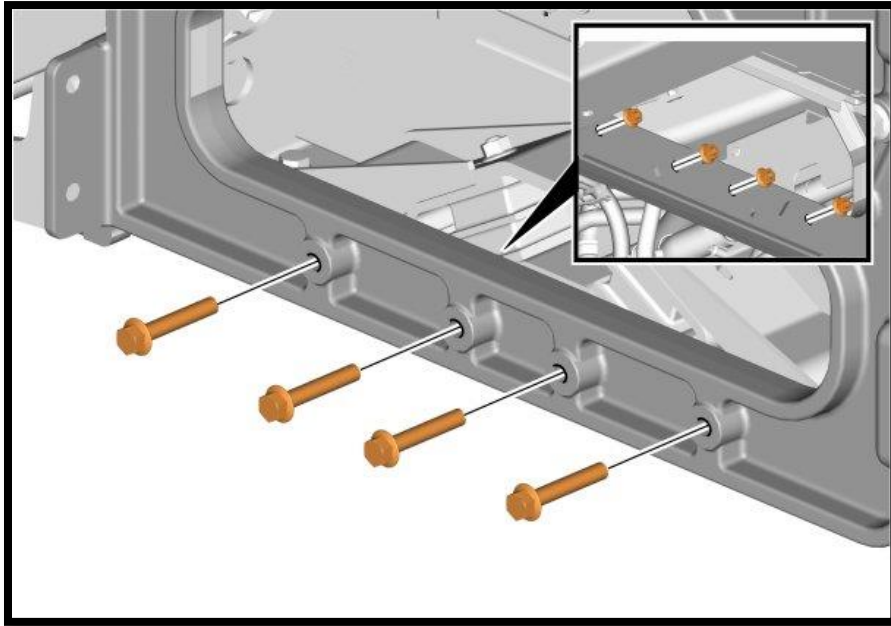

68. Remove the ESS.

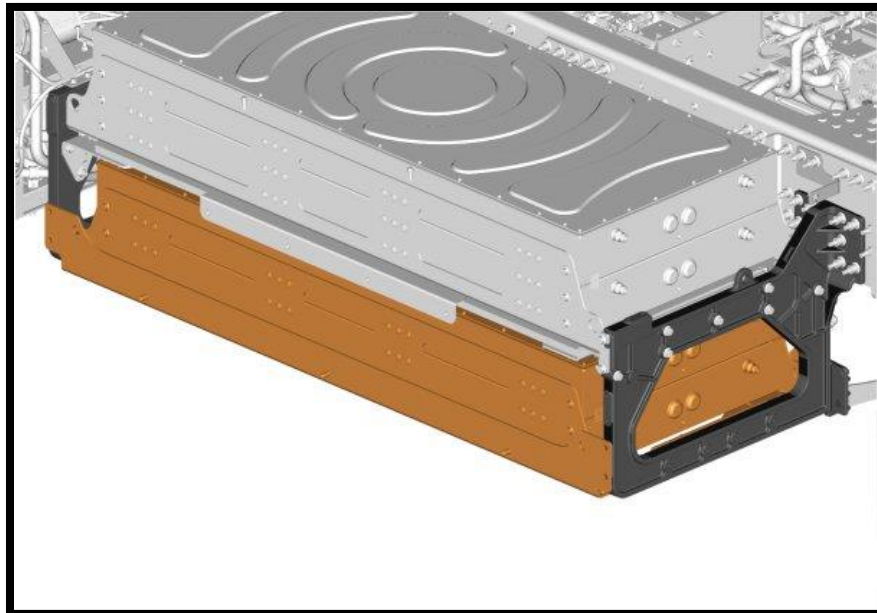

69. Remove the screws.

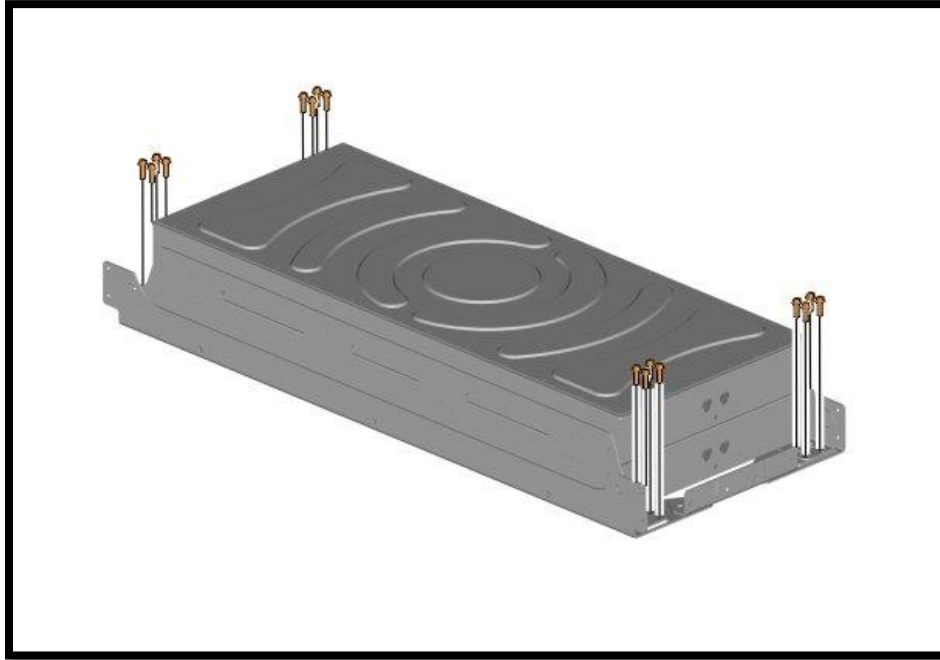

70. Install lifting tool.

71. Remove the battery.

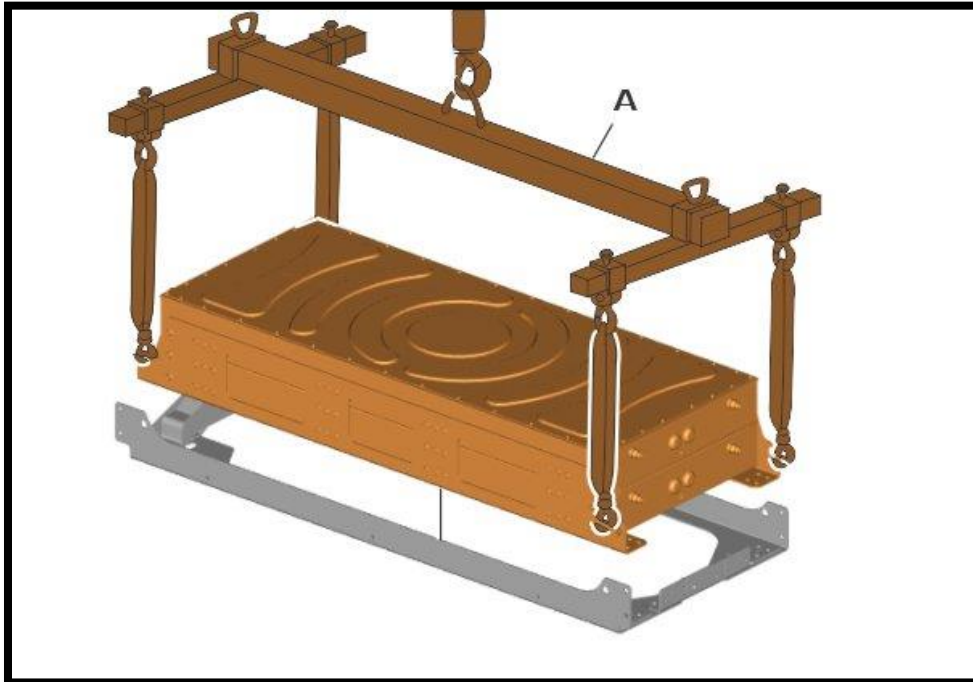

72. Install replacement battery.



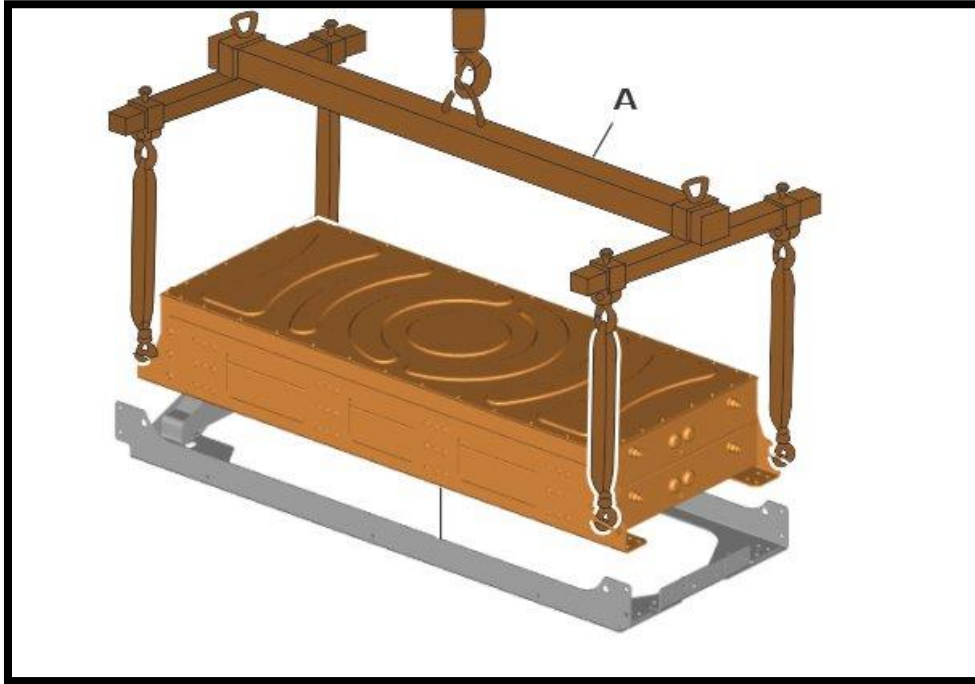

73. Install screws and torque.

Tightening torque	
Bracket, screw	M12
	100 Nm (74 lb·ft)

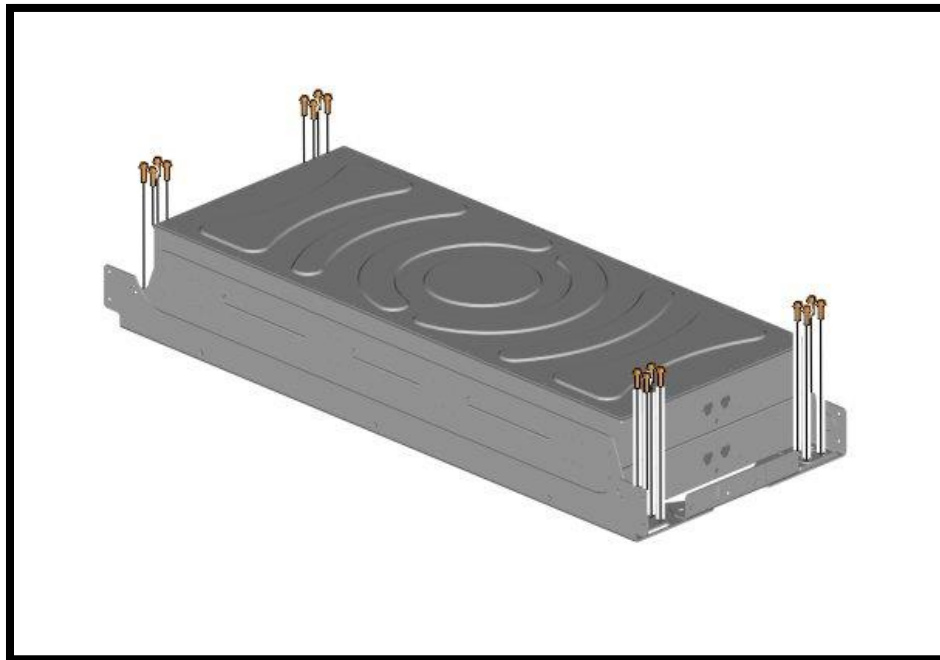

74. Remove the screw.

75. Move aside the cable.

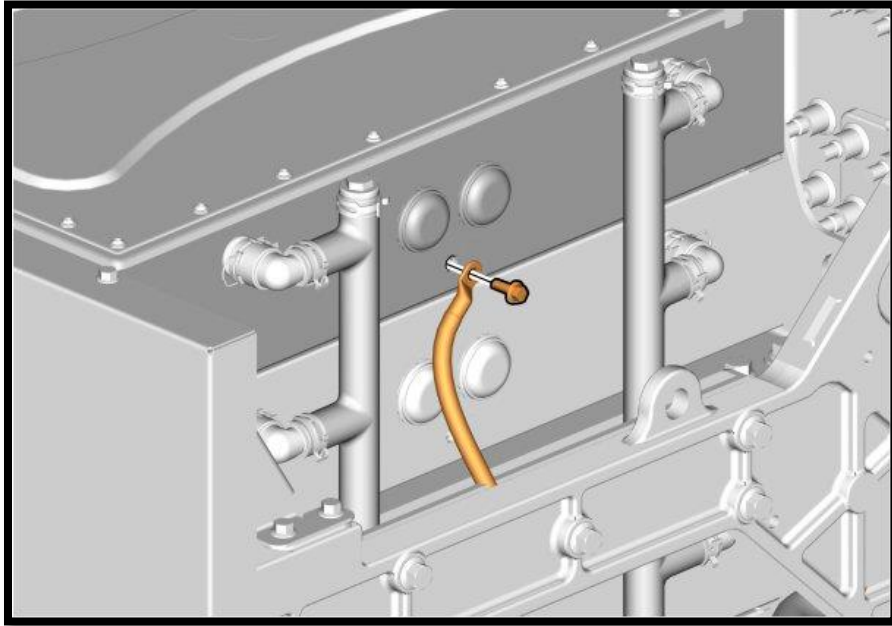

76. Remove the hoses.

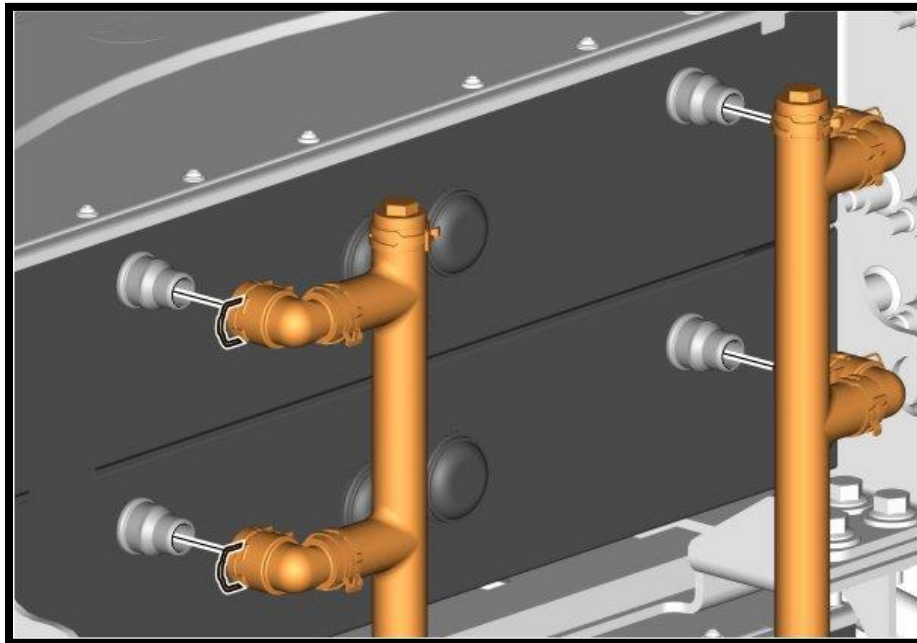

77. Support the ESS.

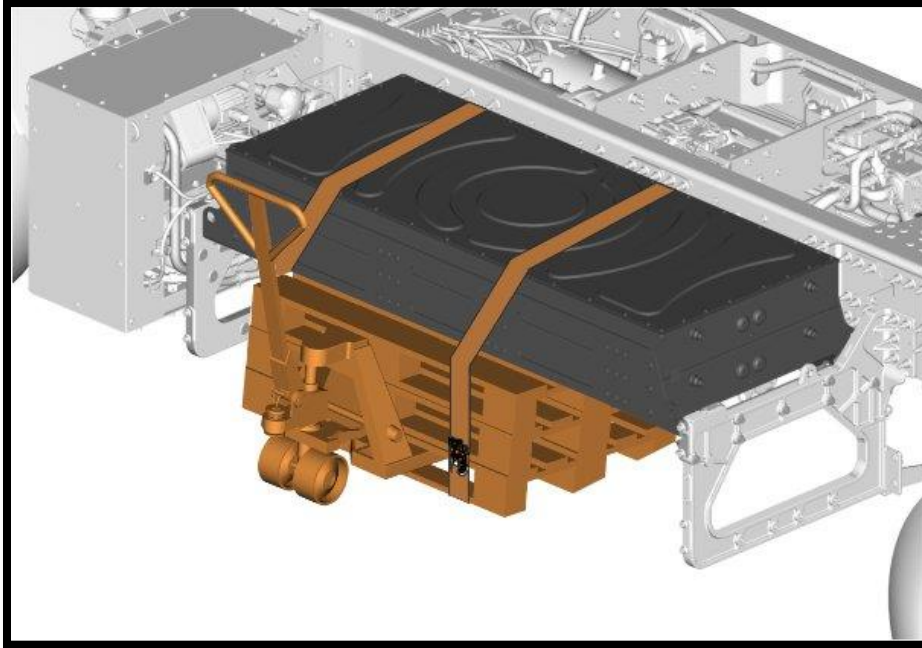

78. Remove the nuts.

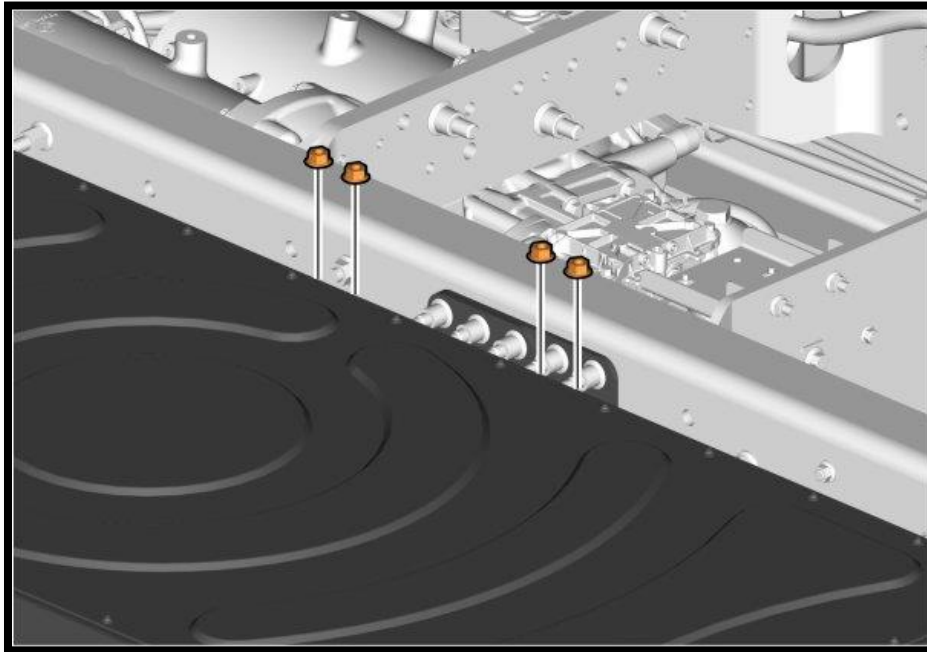

79. Remove the nuts and screws.

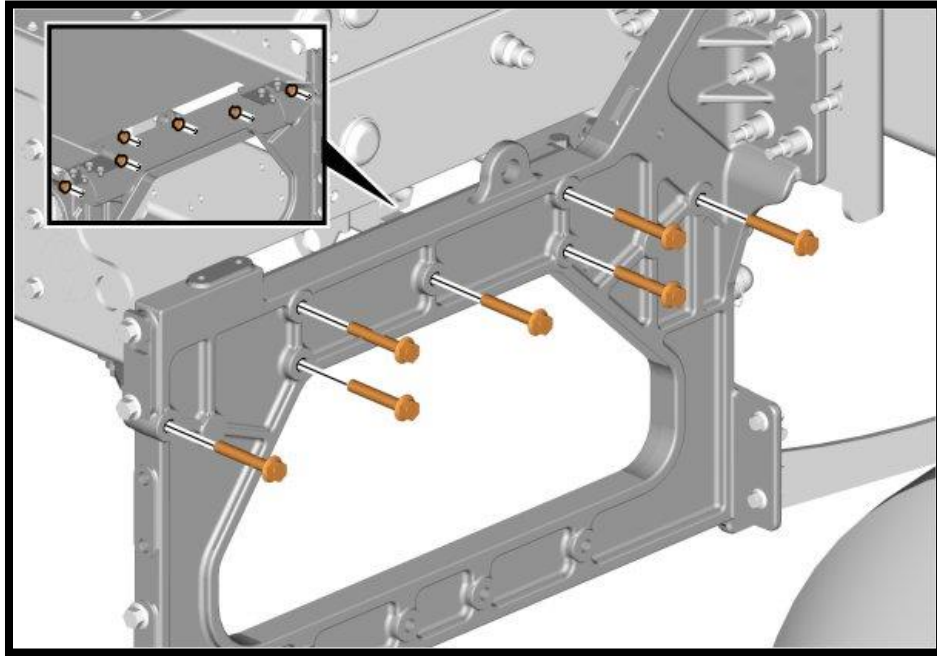

80. Remove the screws.

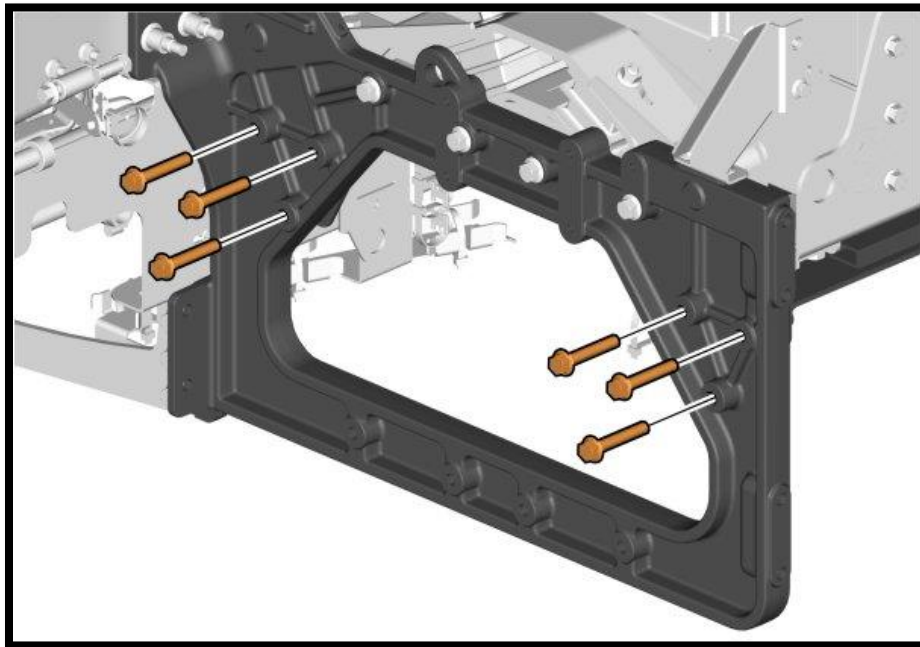

81. Remove the screws.

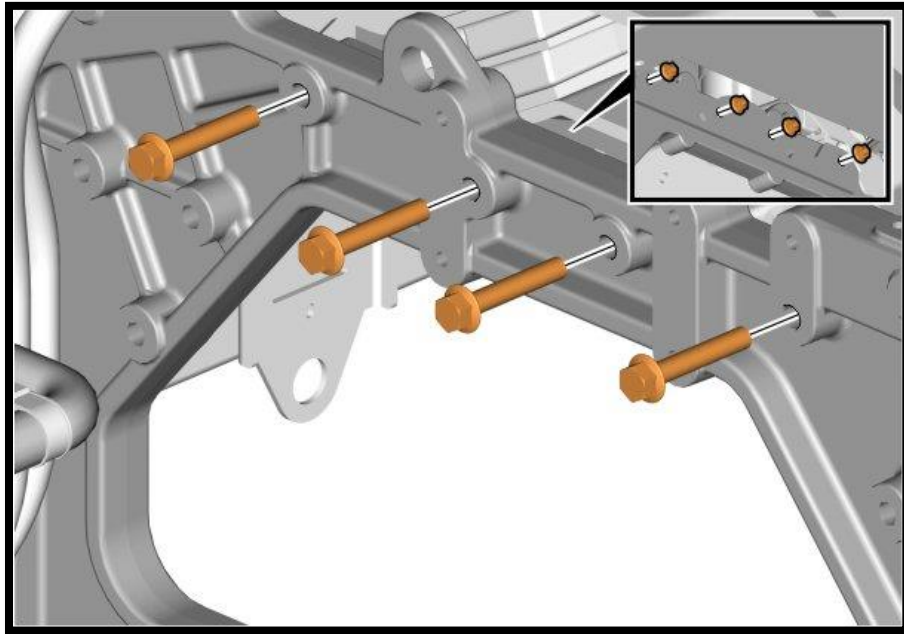

82. Remove the ESS.

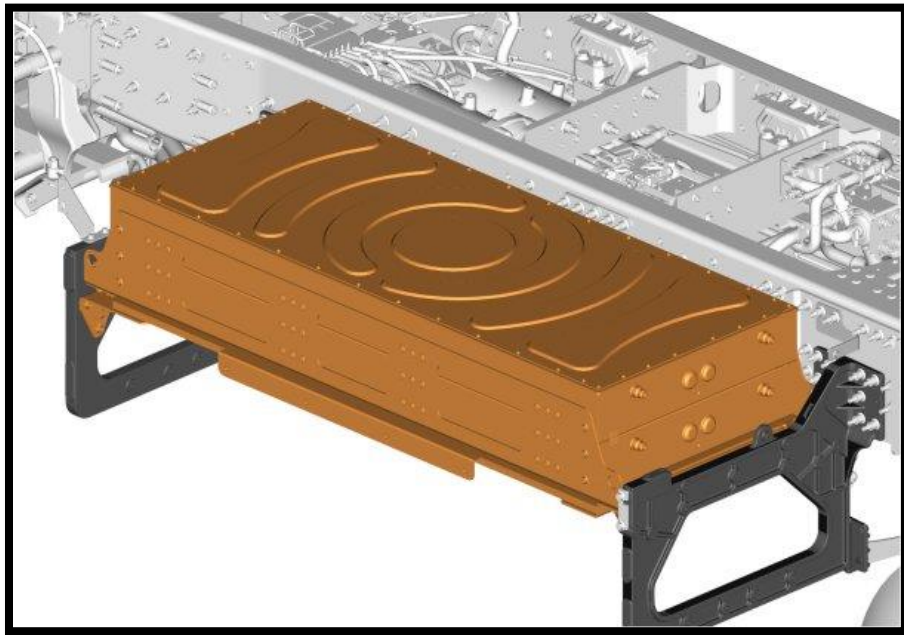

83. Remove the screws.

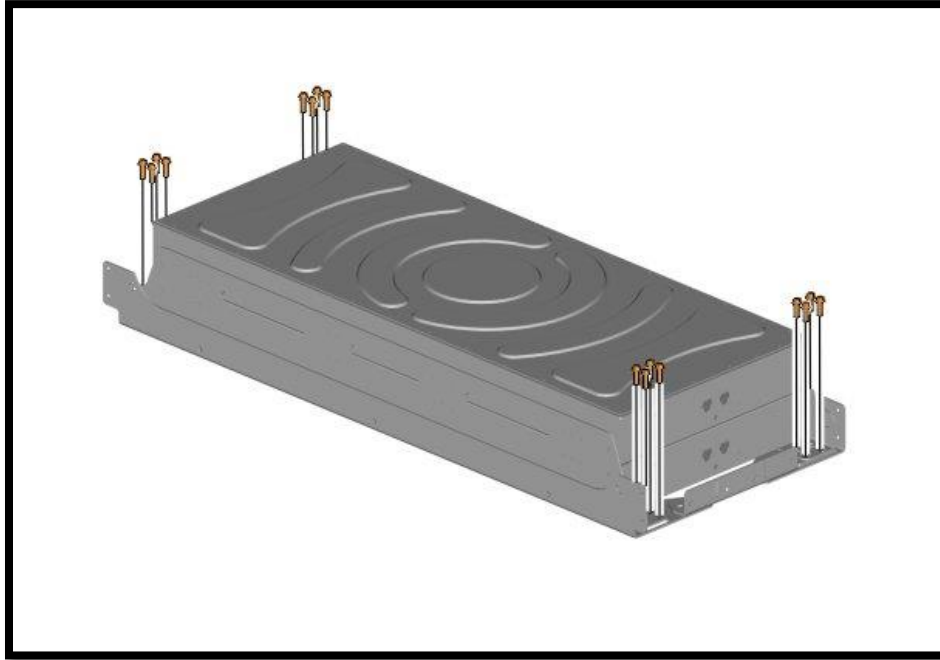

84. Install lifting tool.

85. Remove the battery.

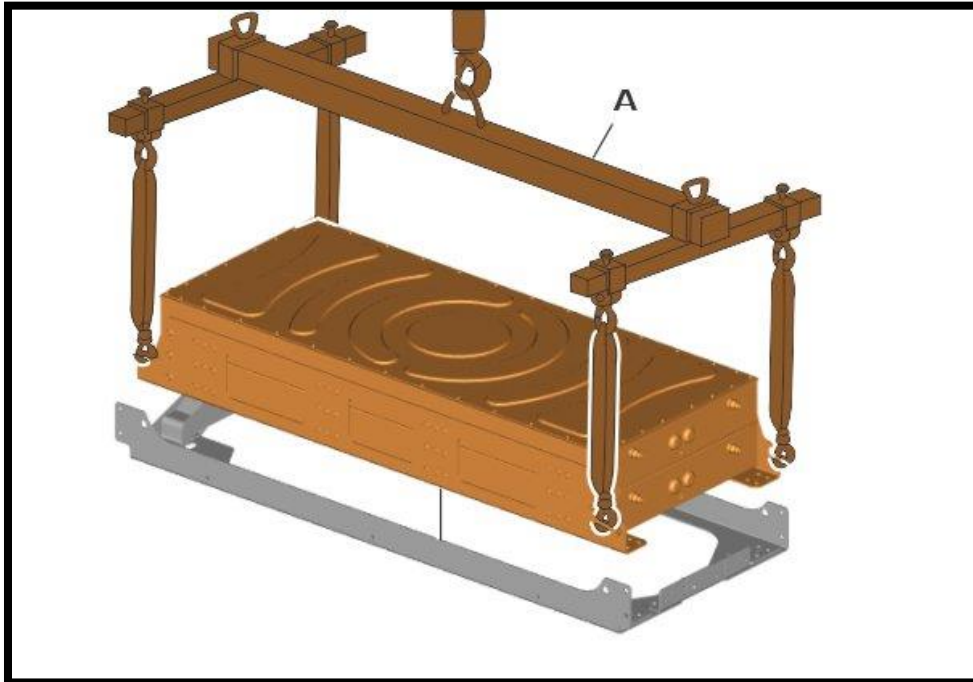

86. Install replacement battery.

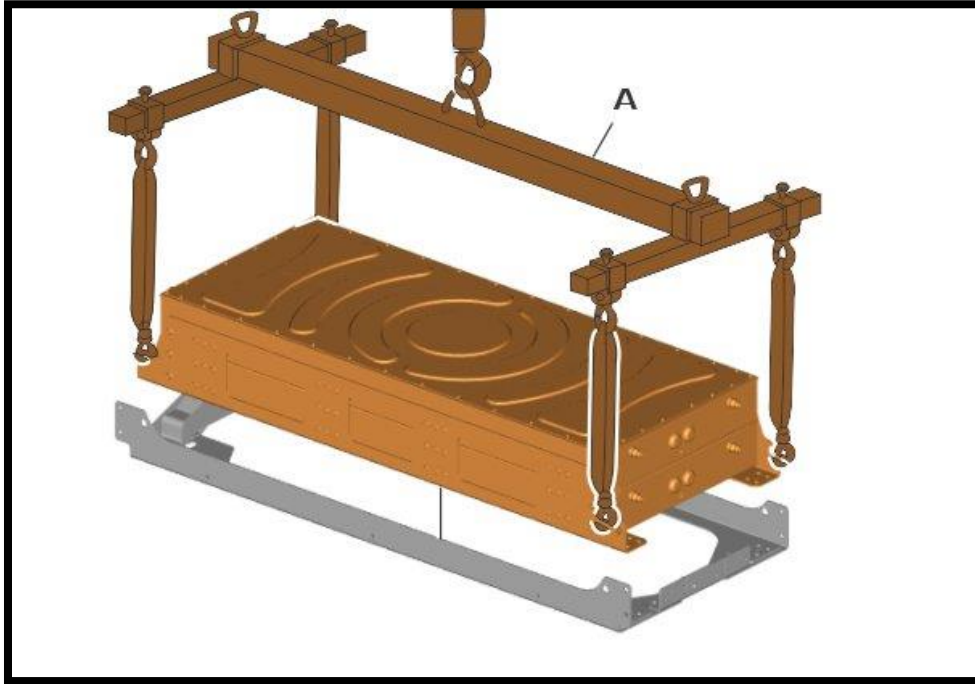

87. Install screws and torque.

Tightening torque	
Bracket, screw	M12
	100 Nm (74 lb·ft)

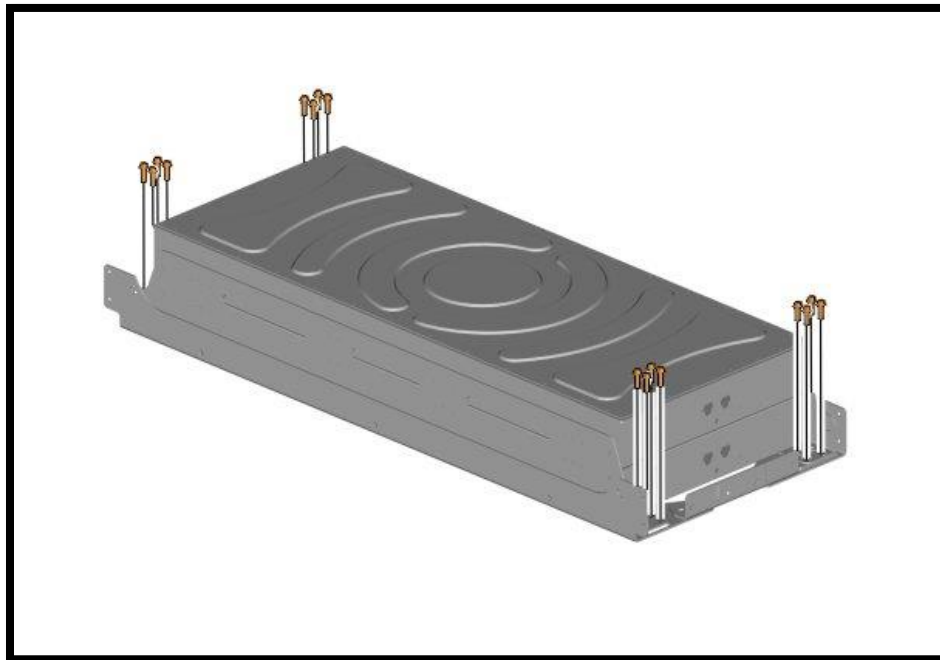

88. Remove the nuts and the screws.

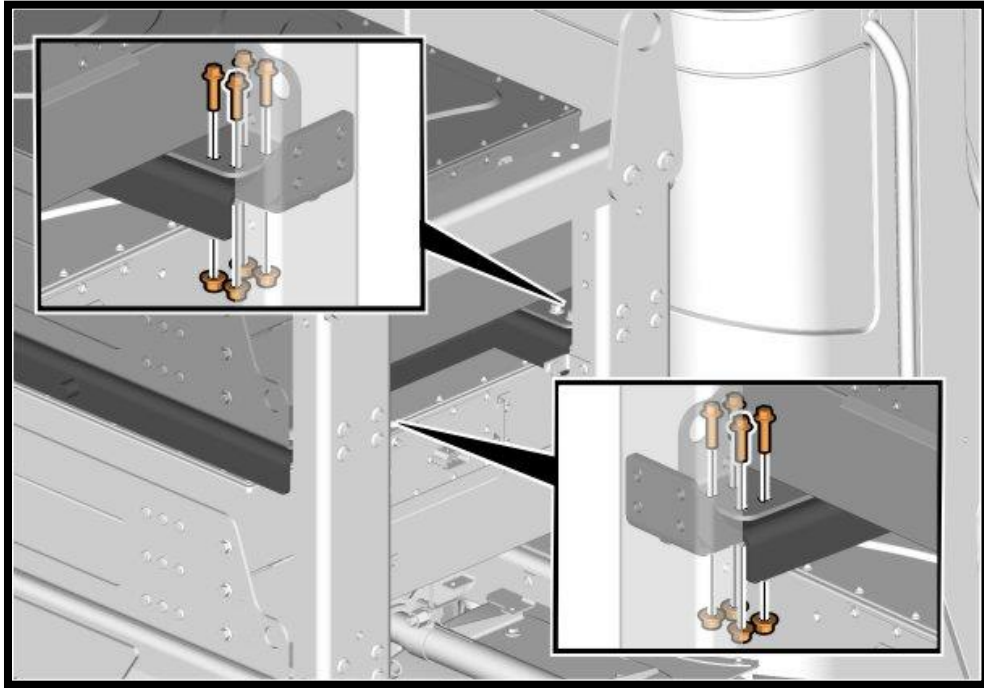

89. Install the lifting tool.

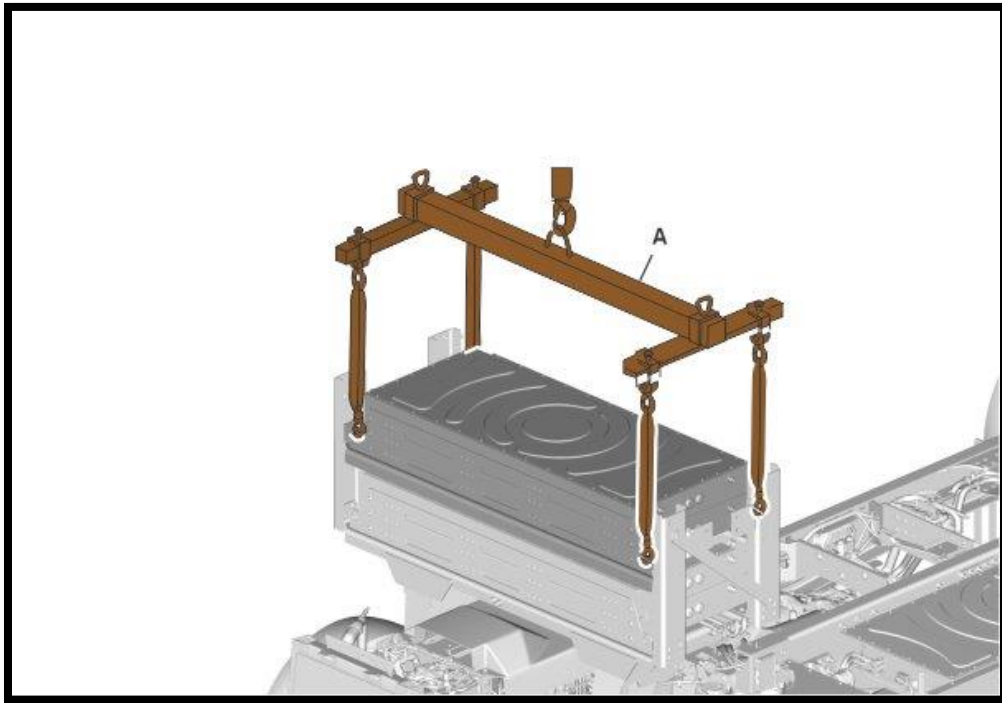



90. Remove the ESS.

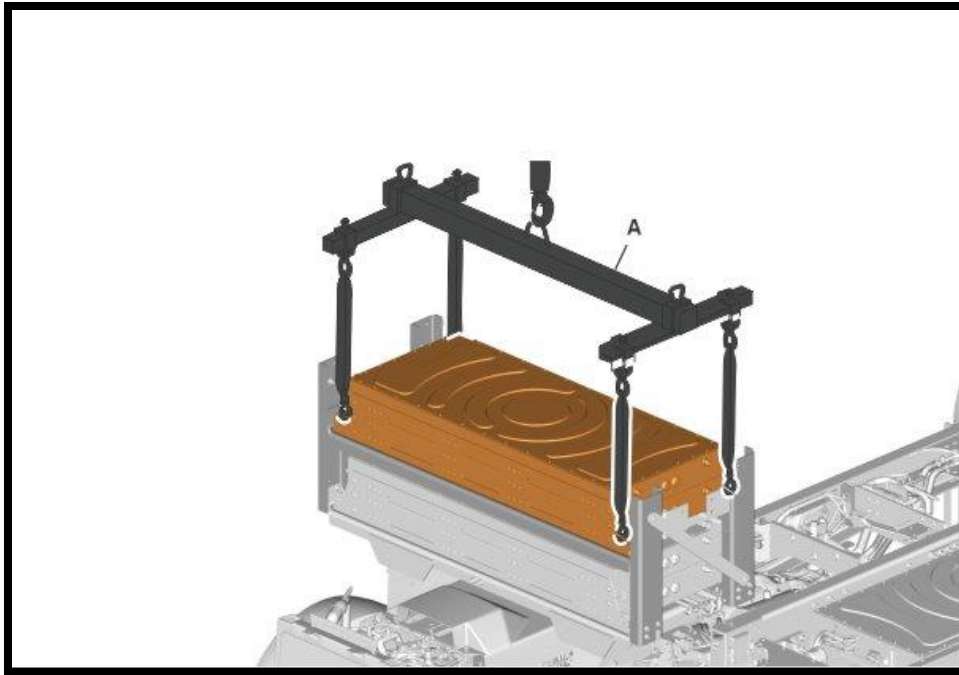

91. Remove the nuts and screws.

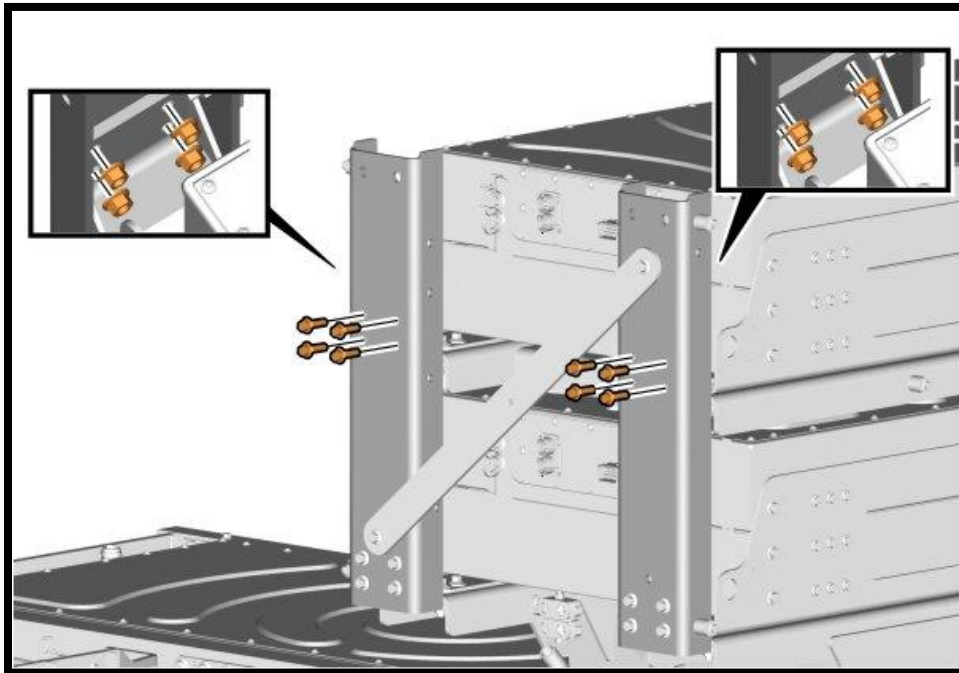

92. Perform the same operation on the other side.

93. Remove the assembly.

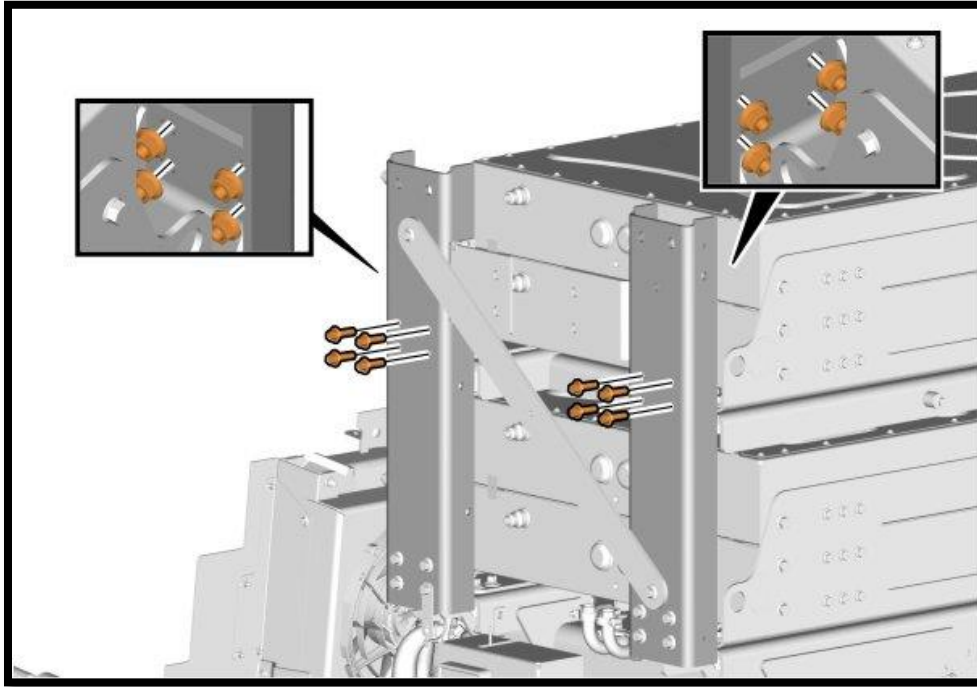

94. Remove the nuts and the screws.

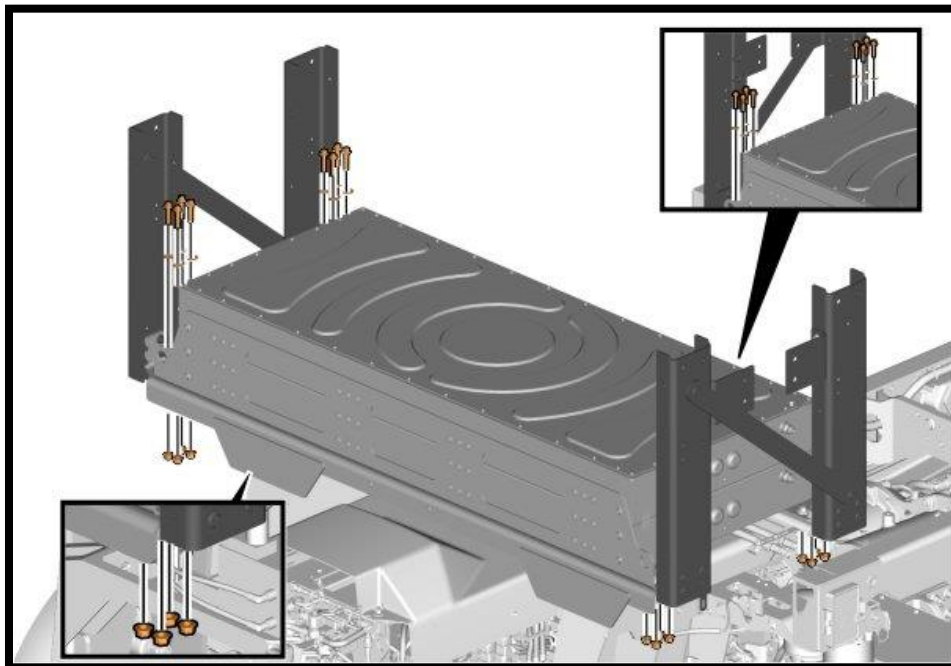

95. Perform the same operation on the other side.

96. Install lifting tool.

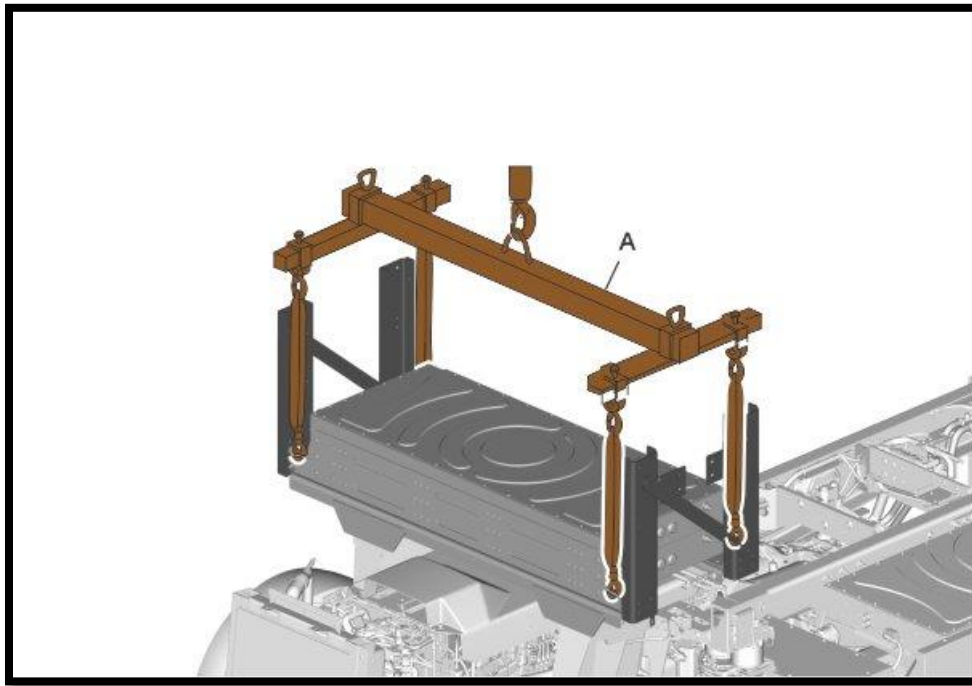

97. Remove the ESS.

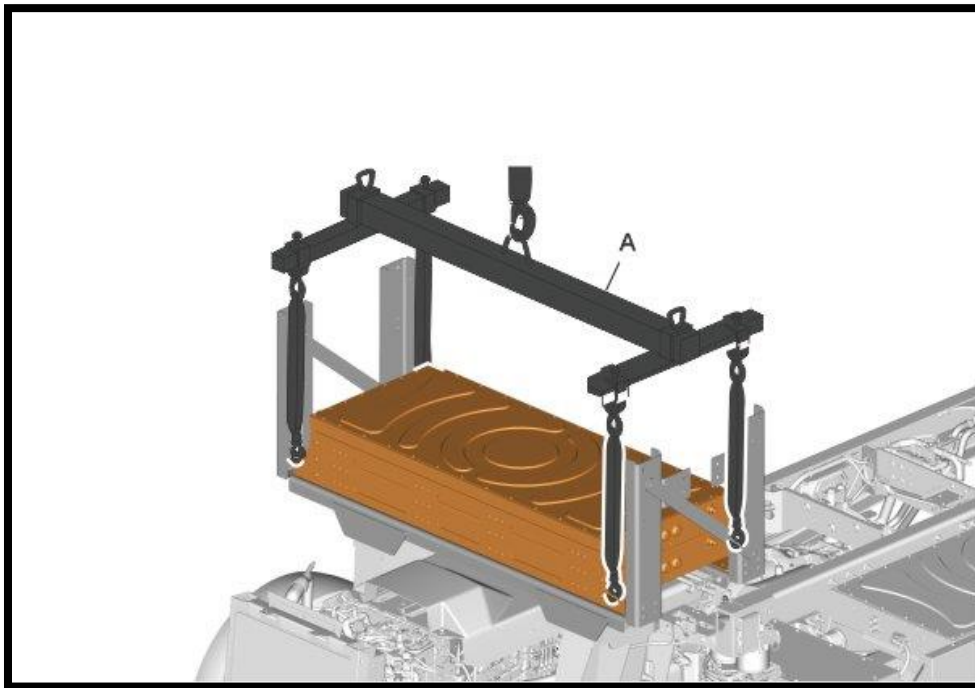

98. Remove the screws.

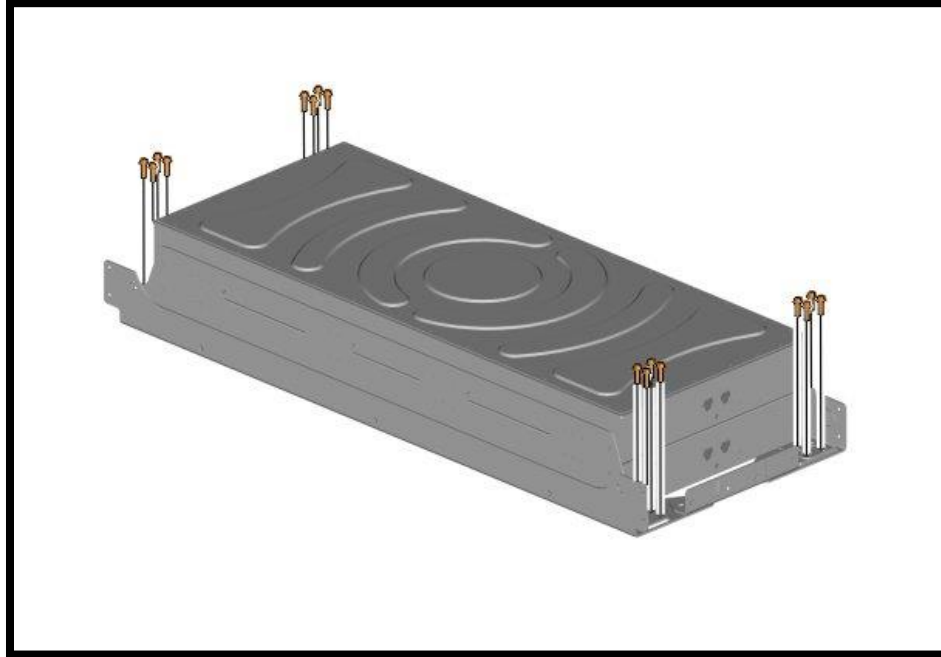

99. Install lifting tool.

100. Remove the battery.

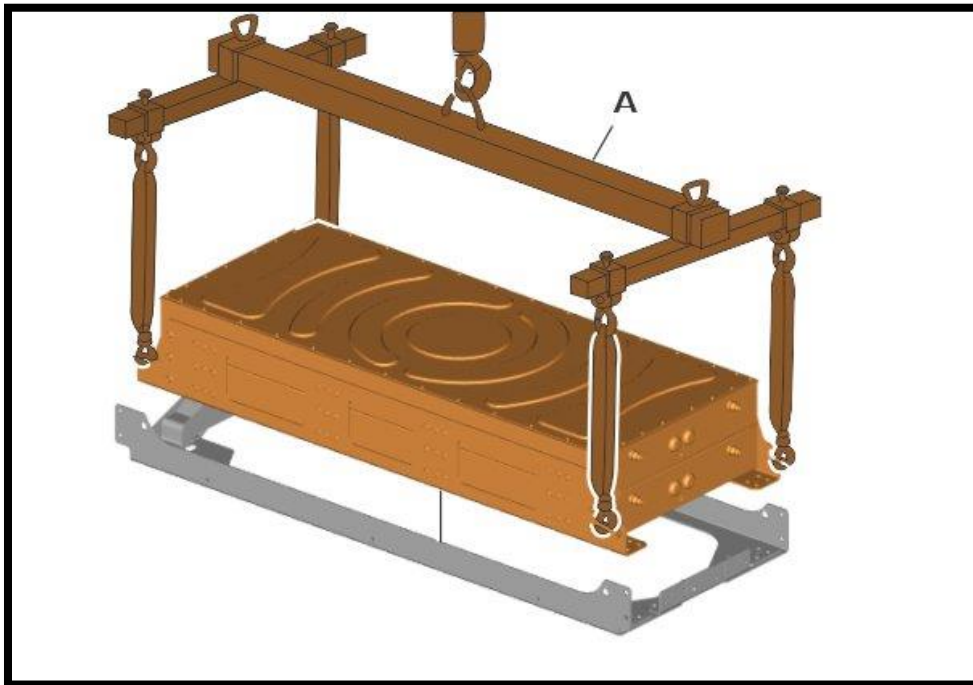

101. Install replacement battery.

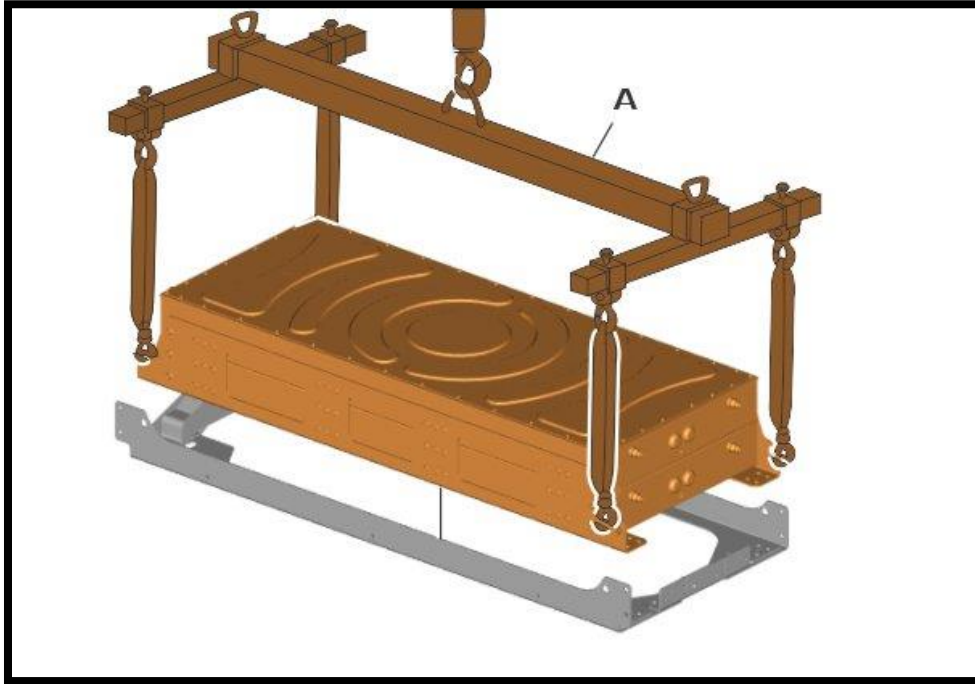

102. Install screws and torque.

Tightening torque	
Bracket, screw	M12
	100 Nm
	(74 lb·ft)

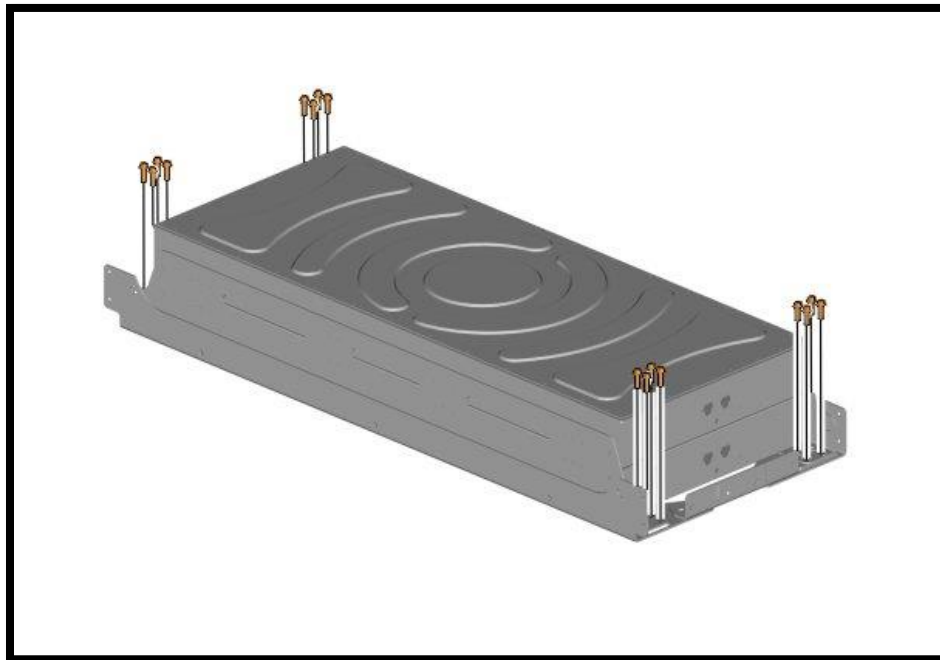

103. Complete steps 98 to 102 on both removed gantry battery packs.

104. Install the ESS.

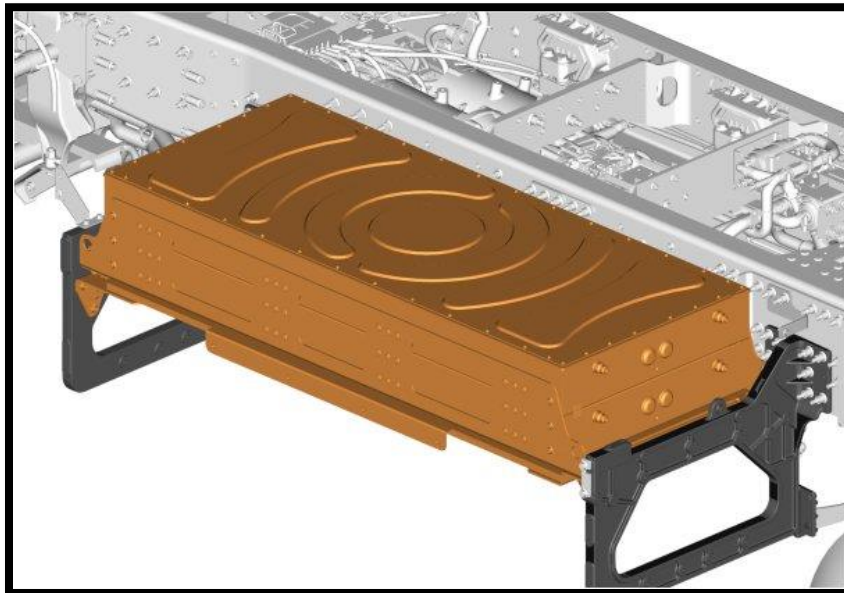

105. Install the screws and the nuts.

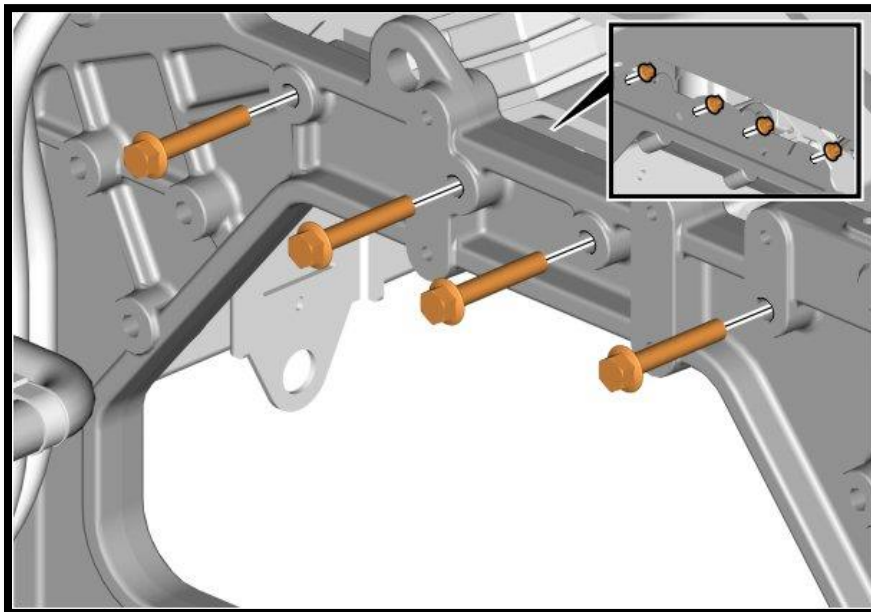

106. Install the screws.

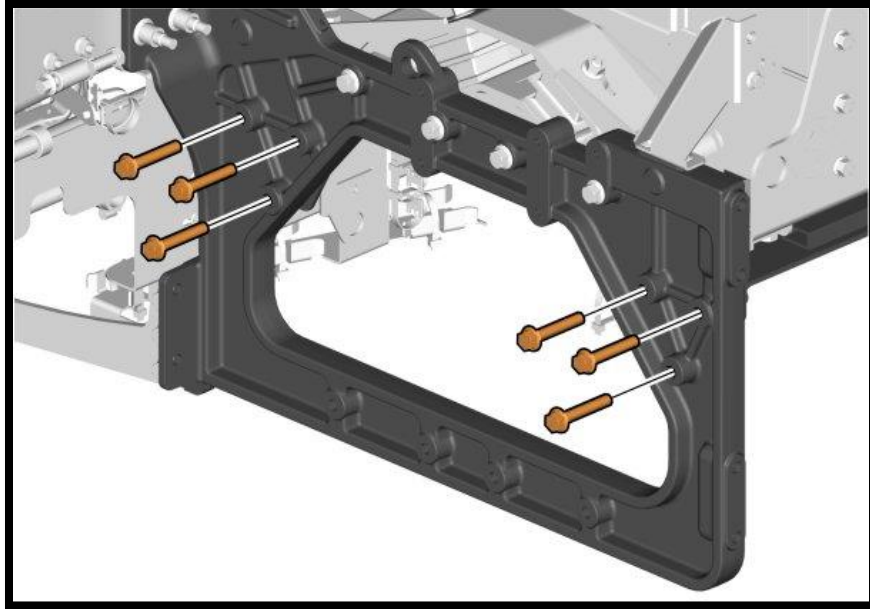

107. Install the screws and the nuts.

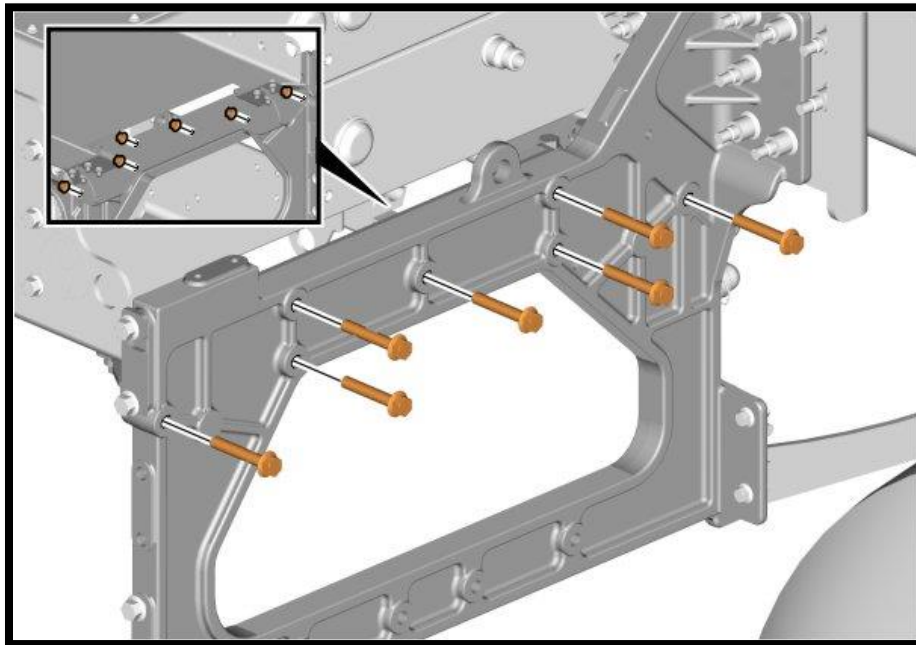

108. Install the nuts.

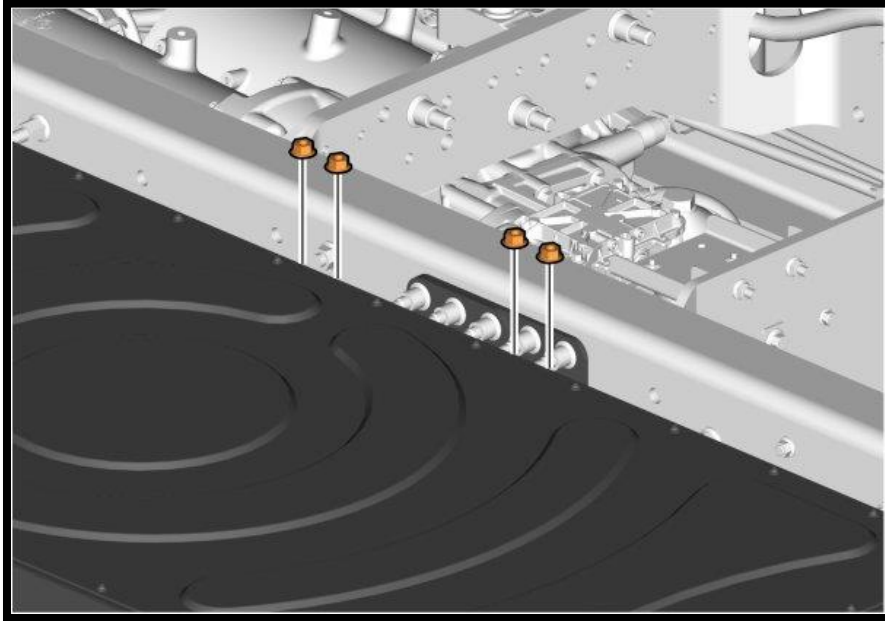

109. Remove the supports.

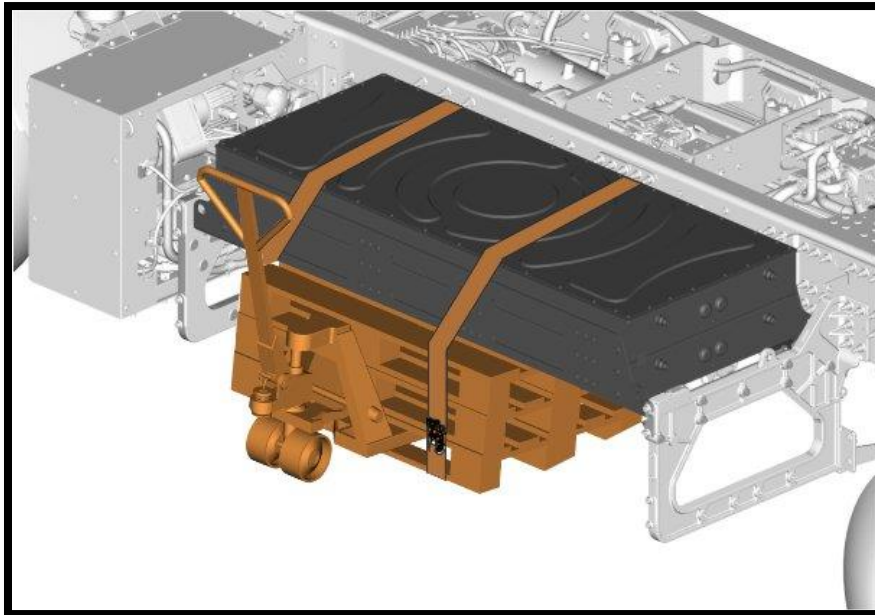



110. Install the hoses.

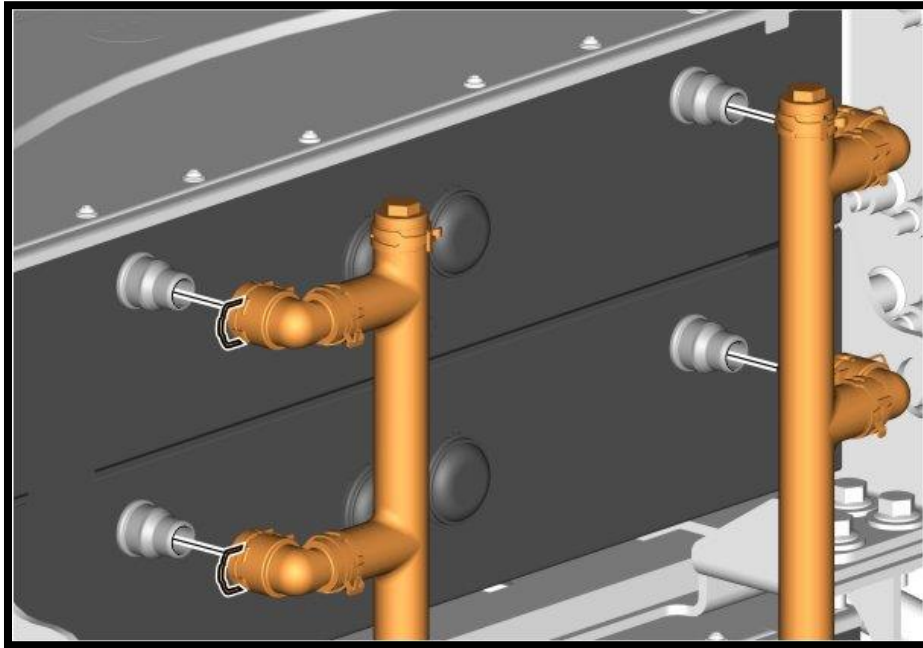

111. Install the cable.

112. Install the screw.

113. Torque the screw.

Tightening torque	
ESS, ground cable, screw	30 ±5 Nm (22 ±4 lb <sub>r</sub> ft)

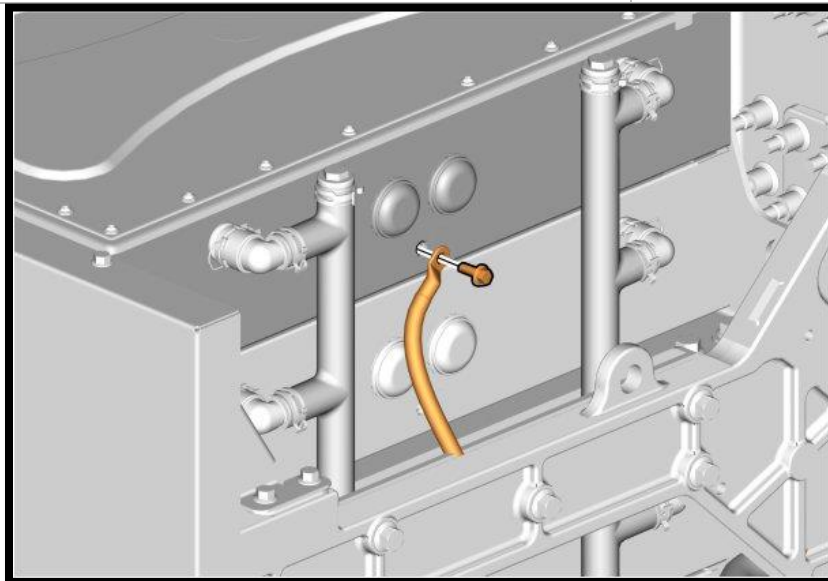

114. Install the ESS.

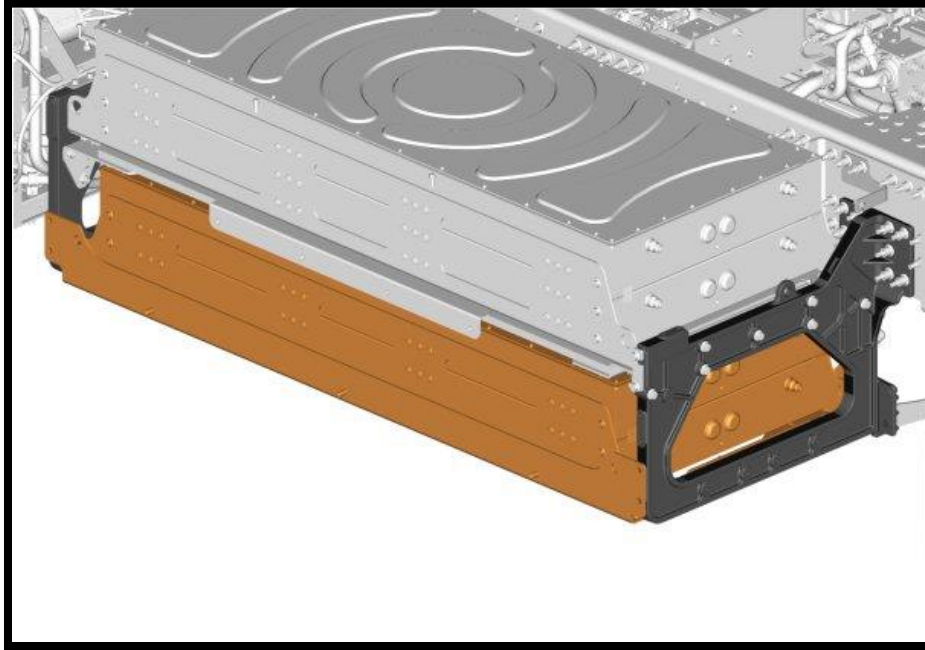

115. Install the screws and the nuts.

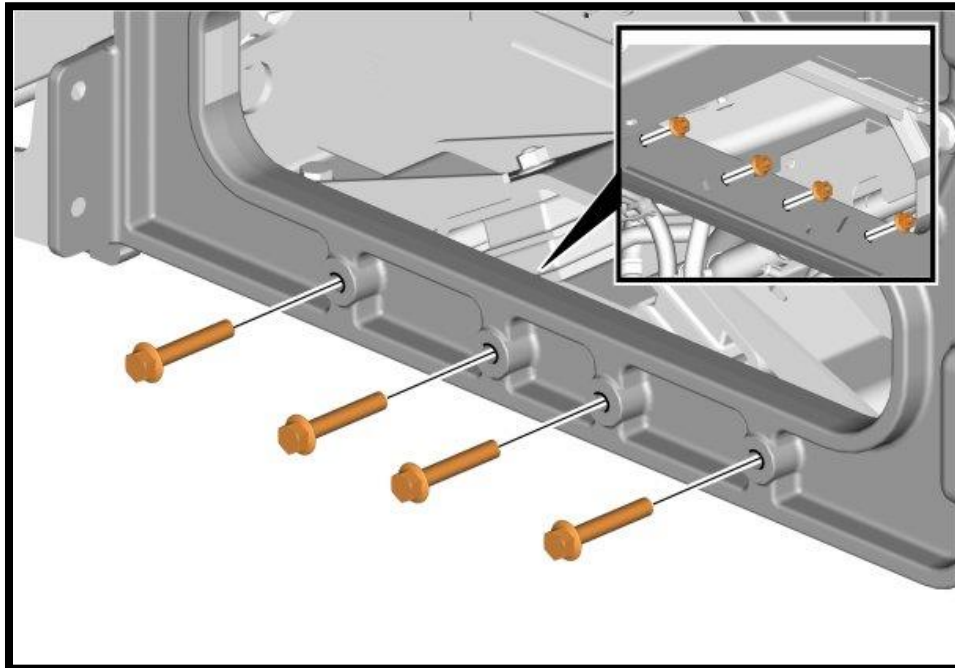

116. Install the screws and the nuts.

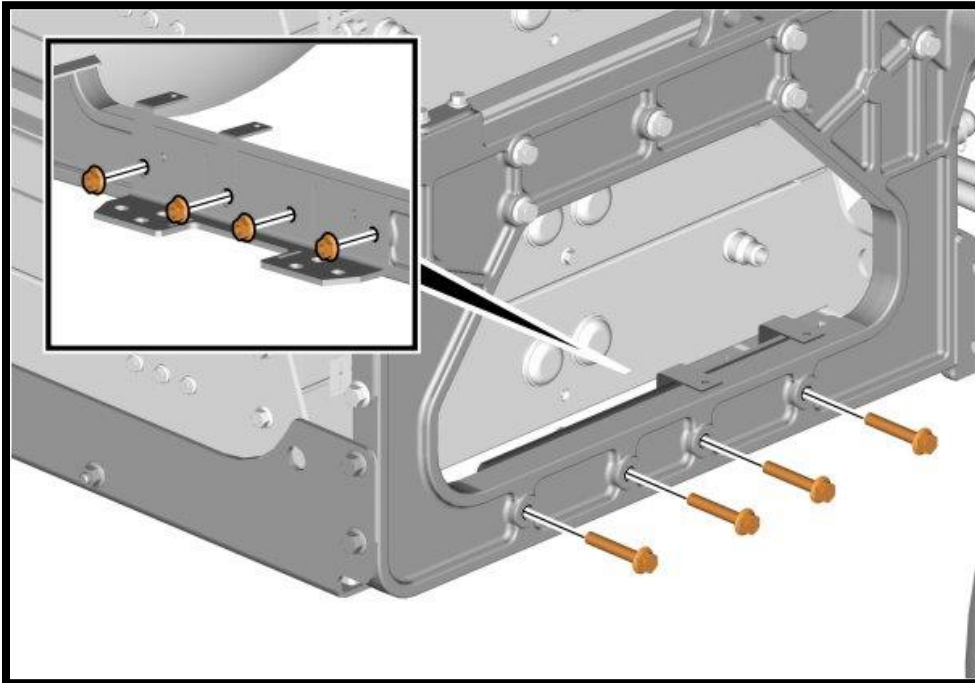

117. Install the screws.

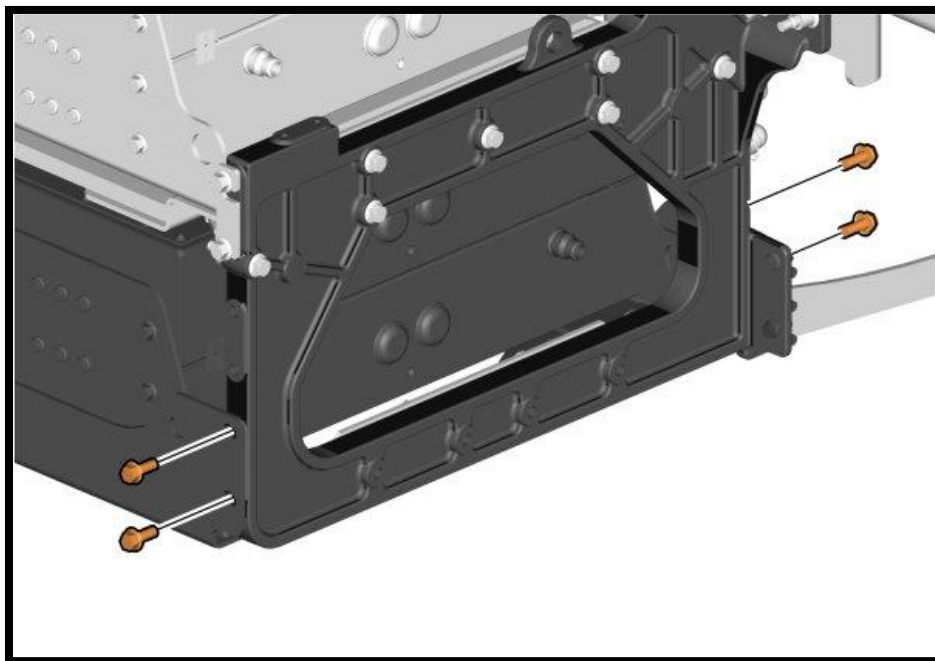

118. Perform the same operation on the other side.
119. Install the screws.

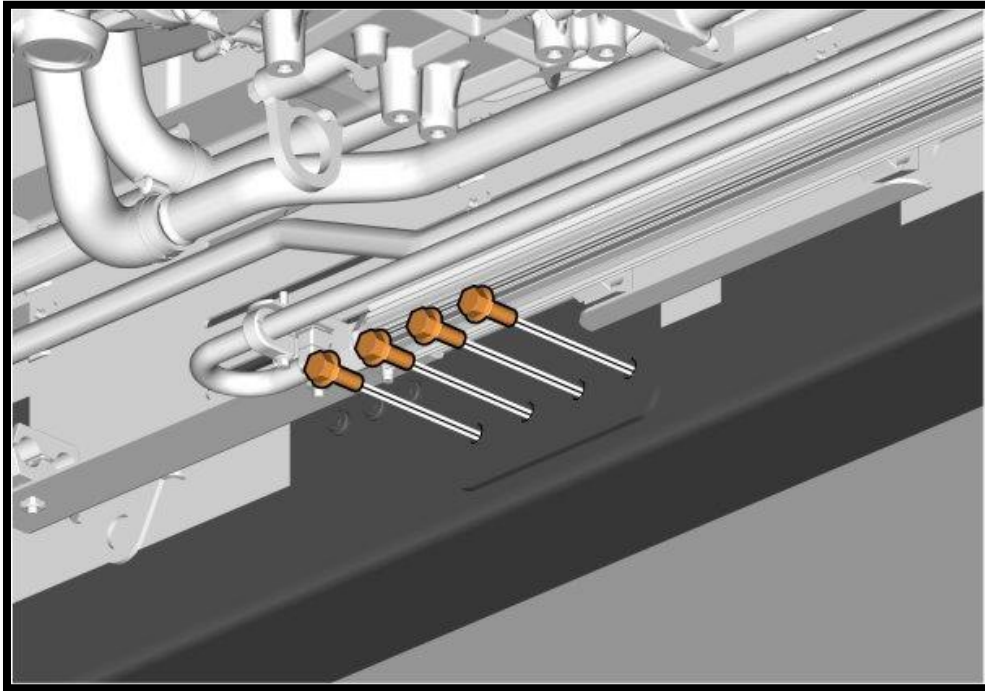

120. Remove the support.

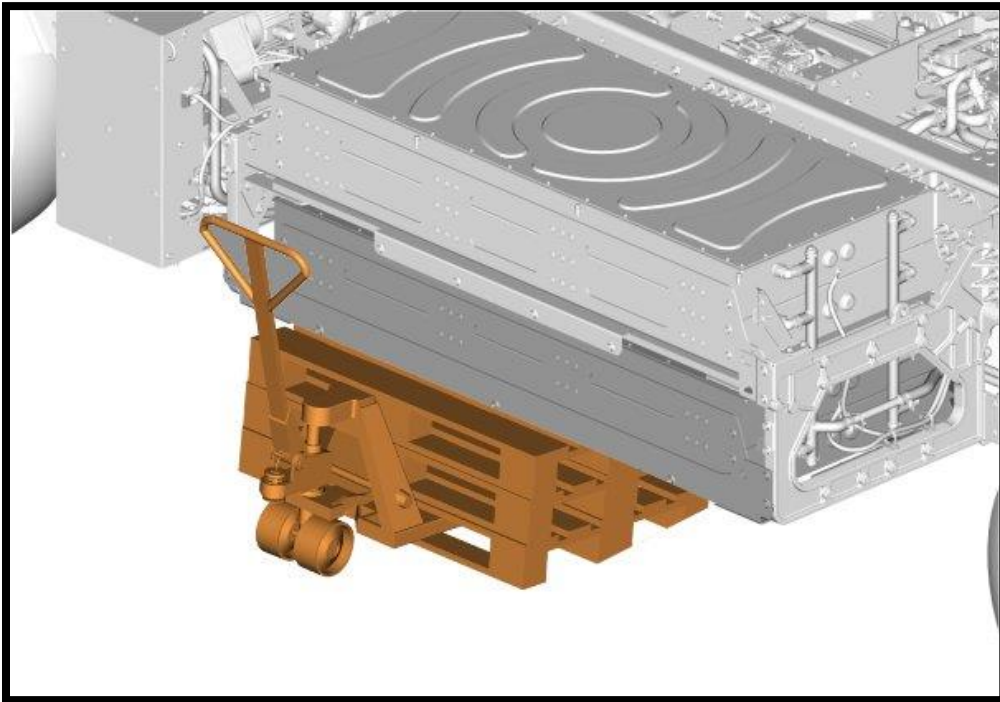

121. Install the hoses.

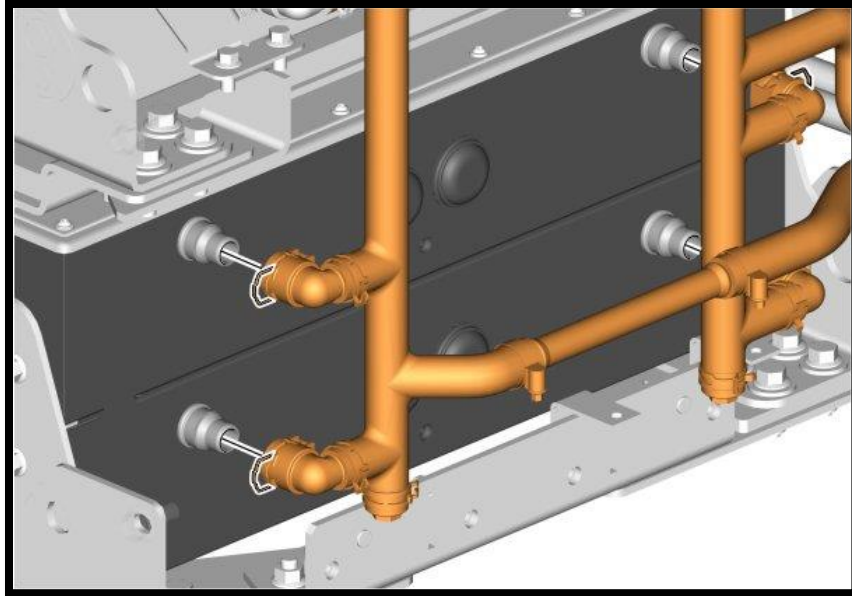

122. Install the cable.

123. Install the screw.

124. Torque the screw.

Tightening torque	
ESS, ground cable, screw	30 ±5 Nm (22 ±4 lb <sub>r</sub> -ft)

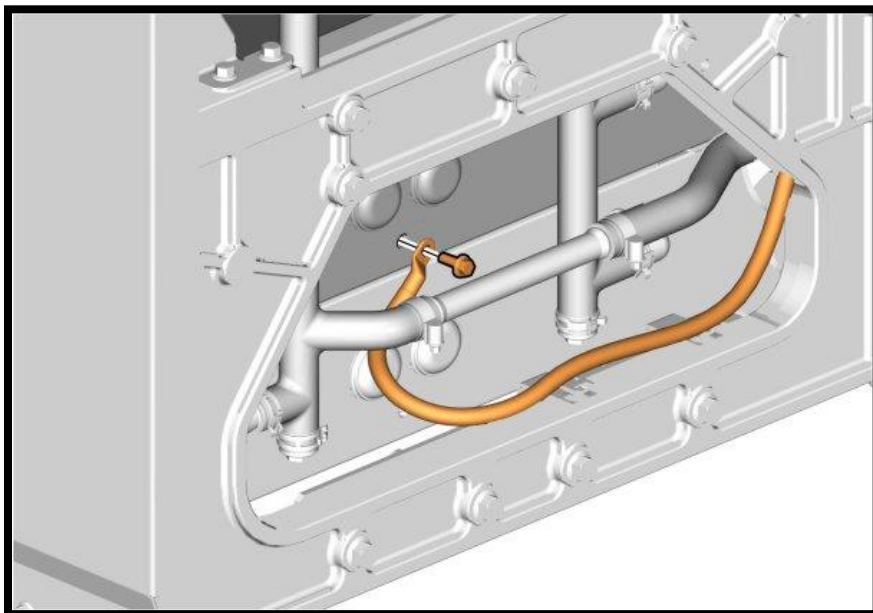

125. Install the cable ties.

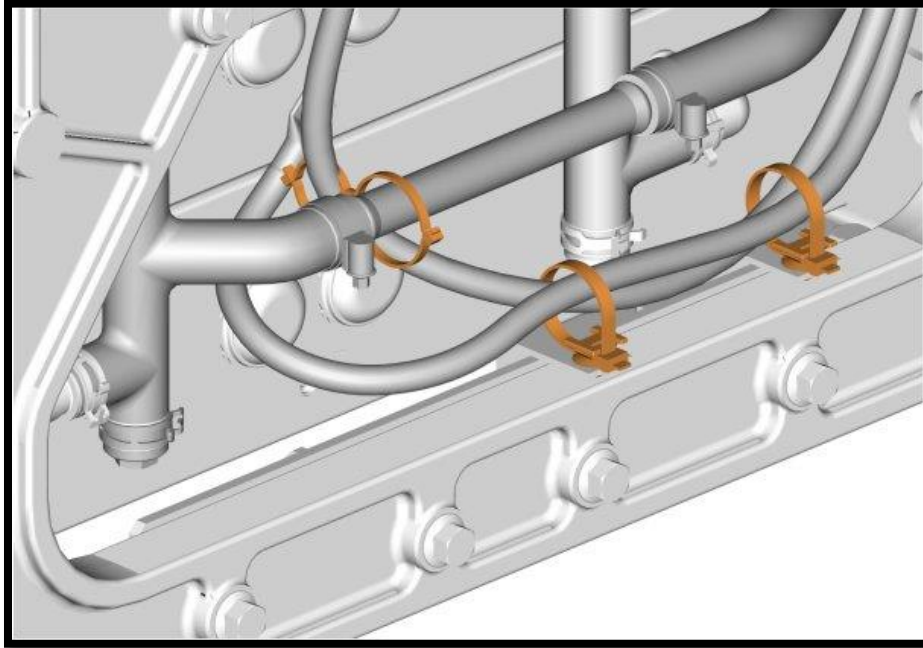

126. Install the protection.

127. Install the screws and the ESS frame.



128. Install new ESS.

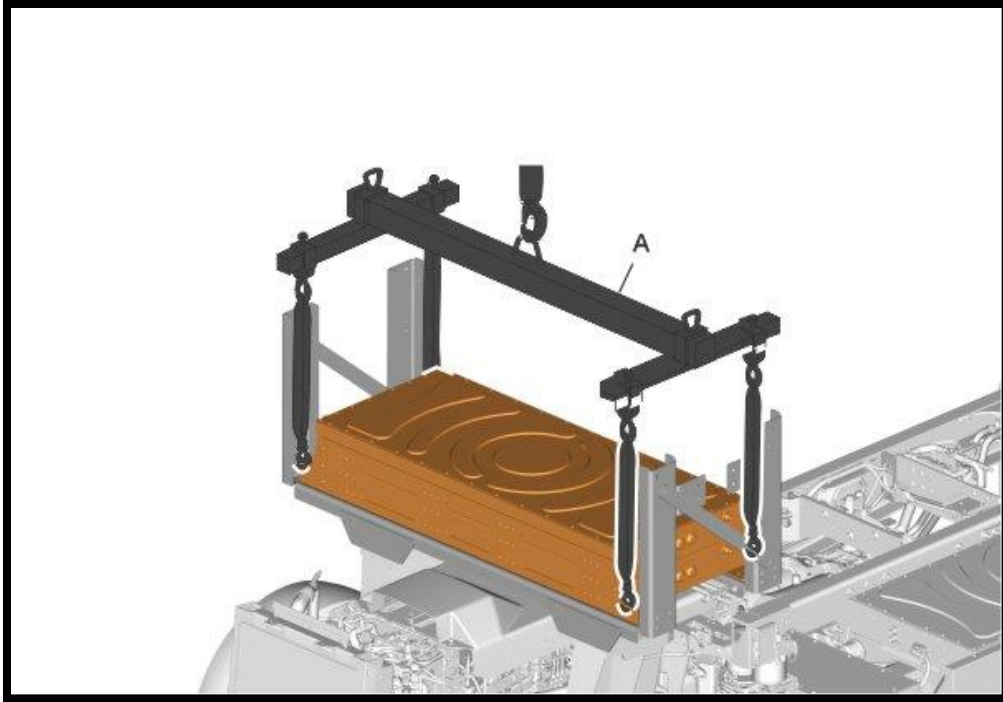

129. Remove lifting tool.

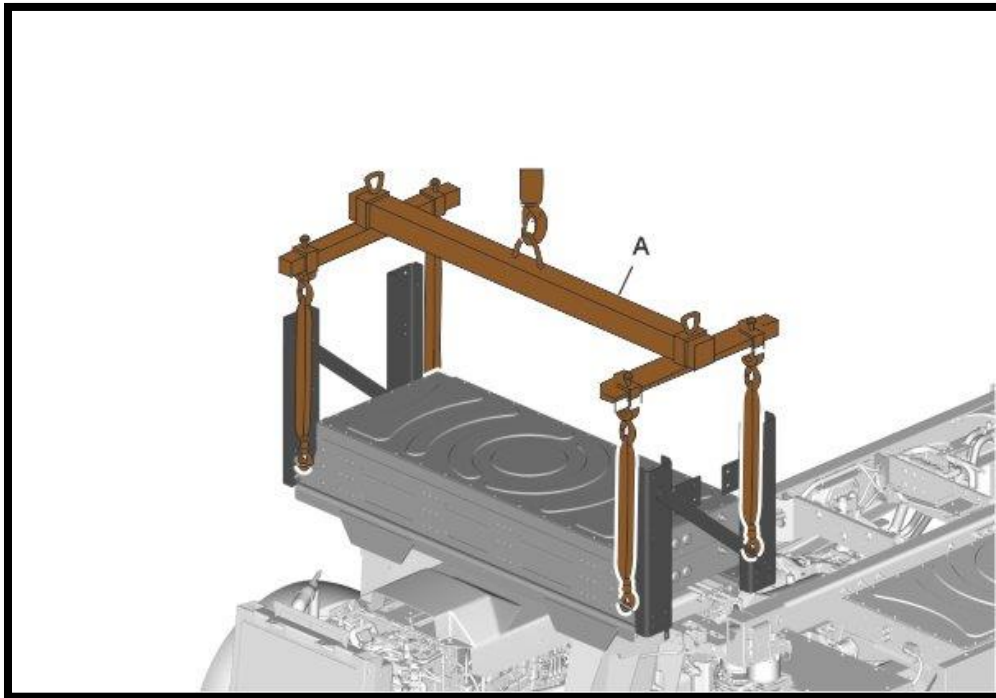

130. Install screws and nuts.

131. Torque screws.

Tightening torque	
Bracket, screw	M12
	100 Nm (74 lb <sub>r</sub> ·ft)

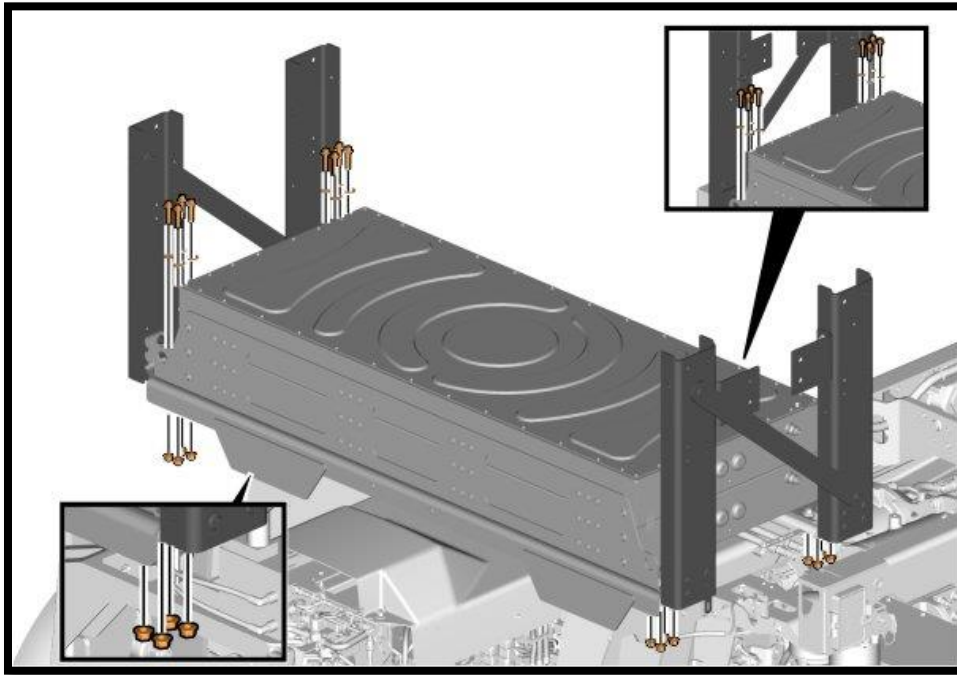

132. Perform the same operation on the other side.



133. Install assembly.

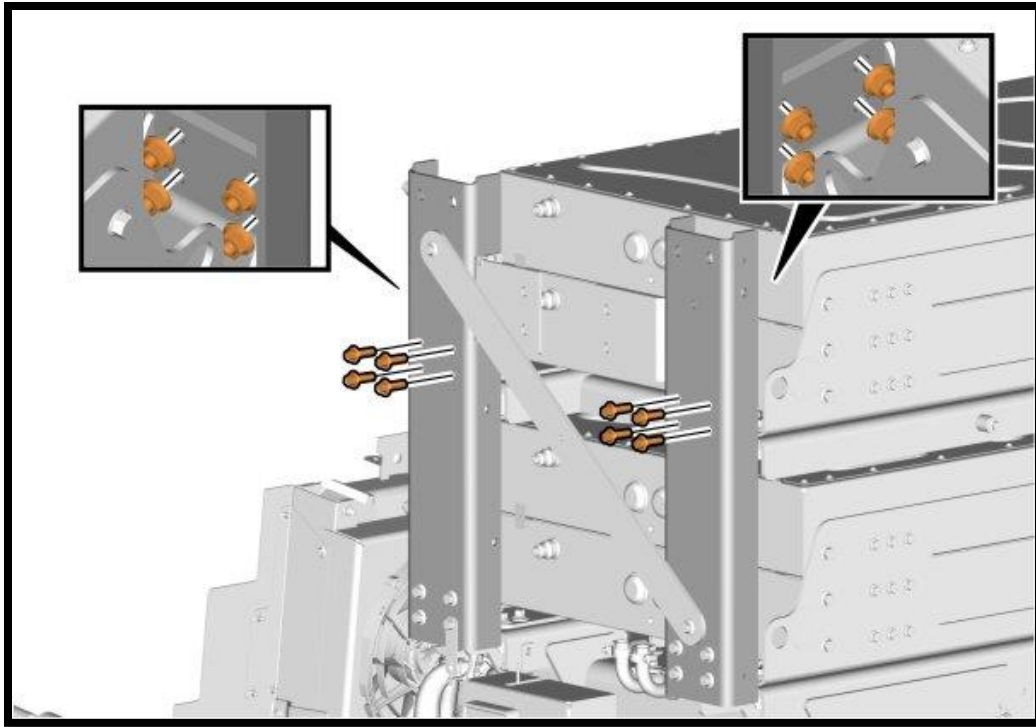

134. Install the screws and nuts.

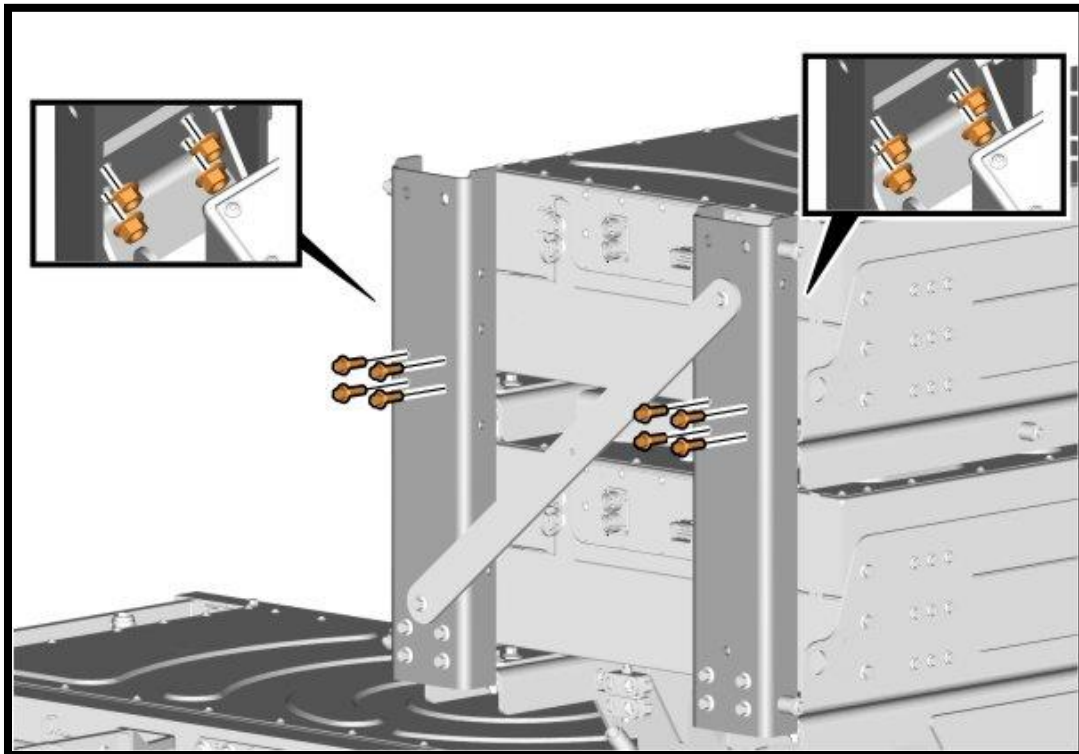

135. Perform the same operation on the other side.

136. Install the ESS.

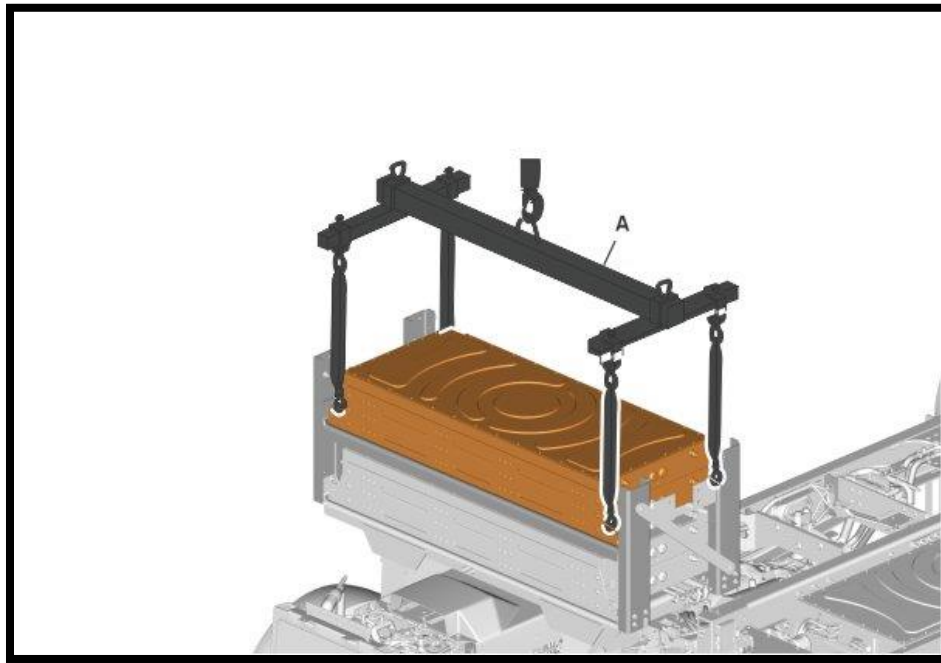

137. Remove the lifting tool.

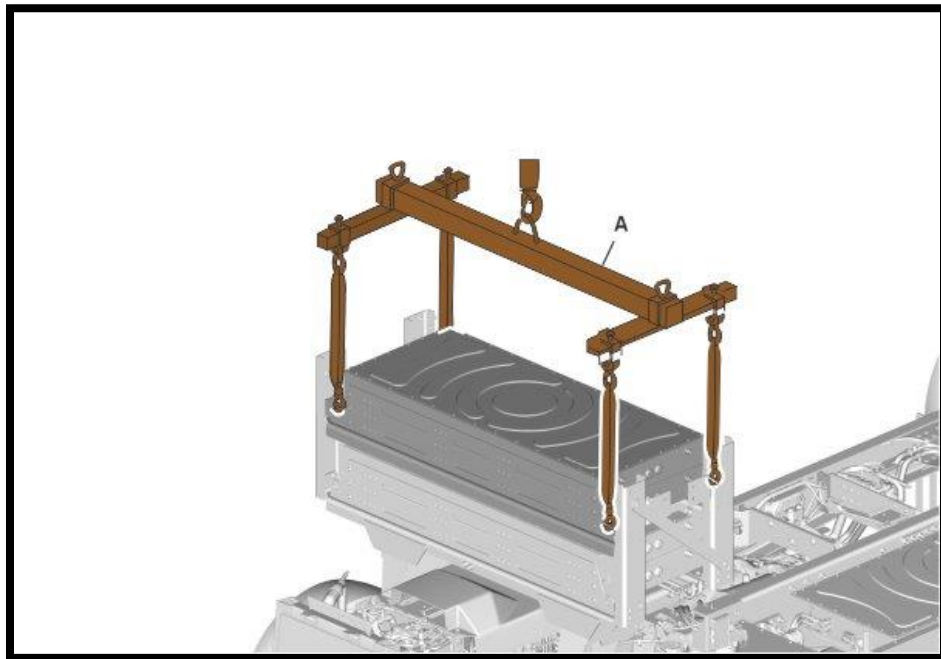

138. Install the screws.

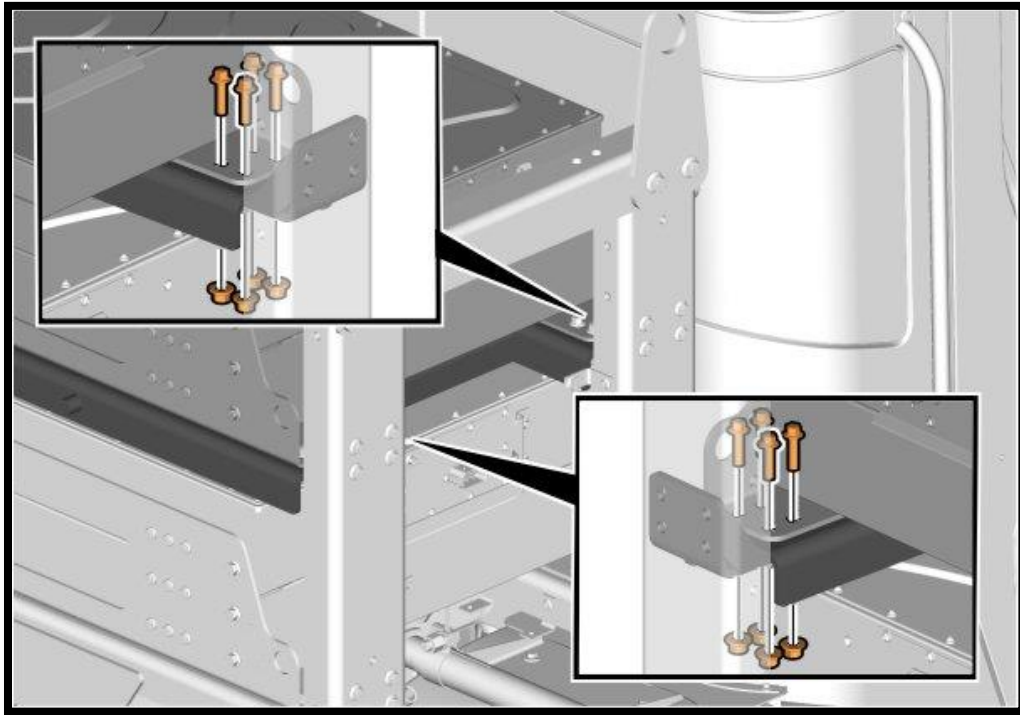

139. Perform the same operation on the other side.

140. Install the lower hoses.

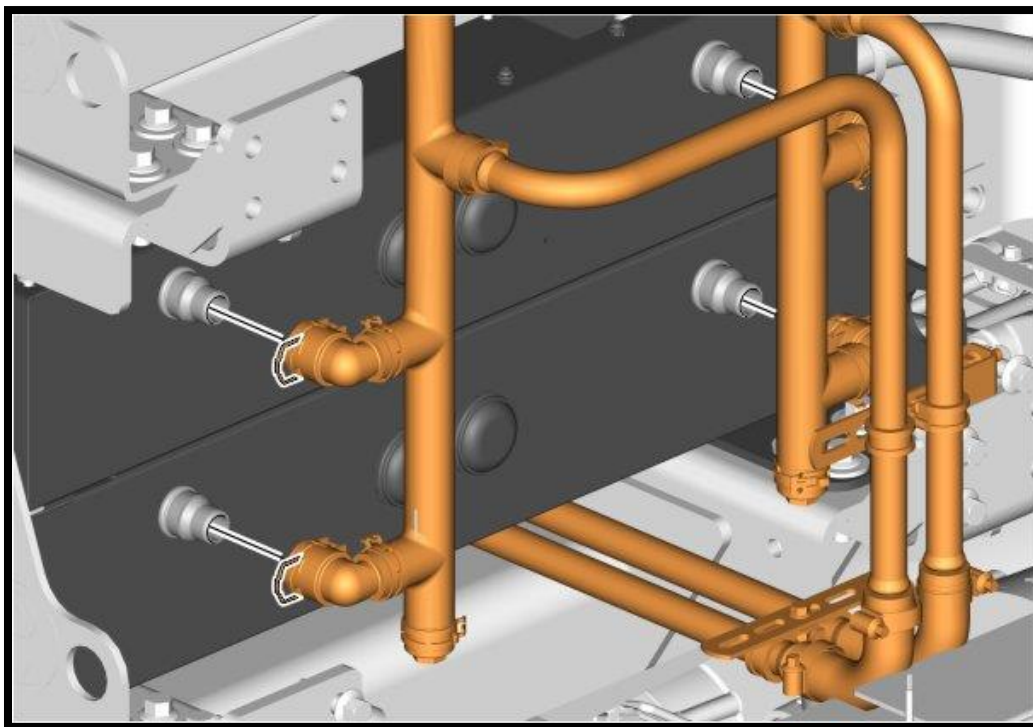

141. Install the upper hoses.

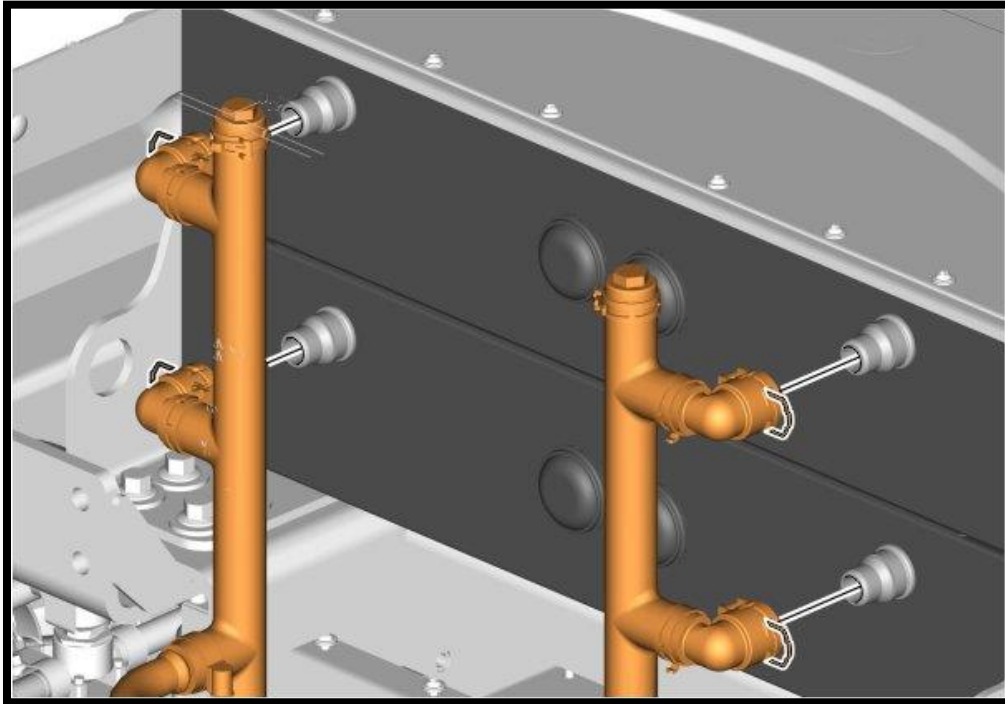

142. Install both upper and lower cable and their screws.

143. Torque the screws.

Tightening torque	
ESS, ground cable, screw	30 ±5 Nm (22 ±4 lb <sub>r</sub> ·ft)

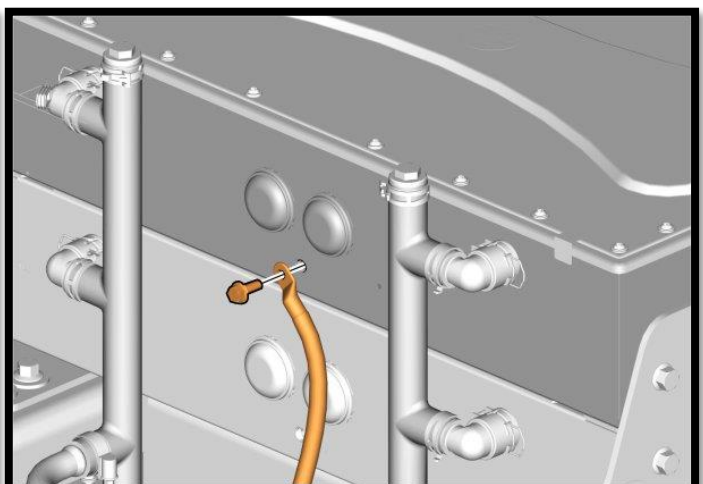
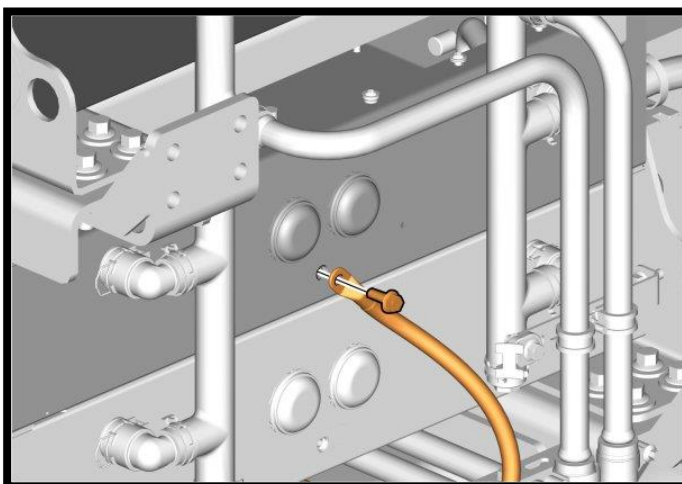

144. Install the hose

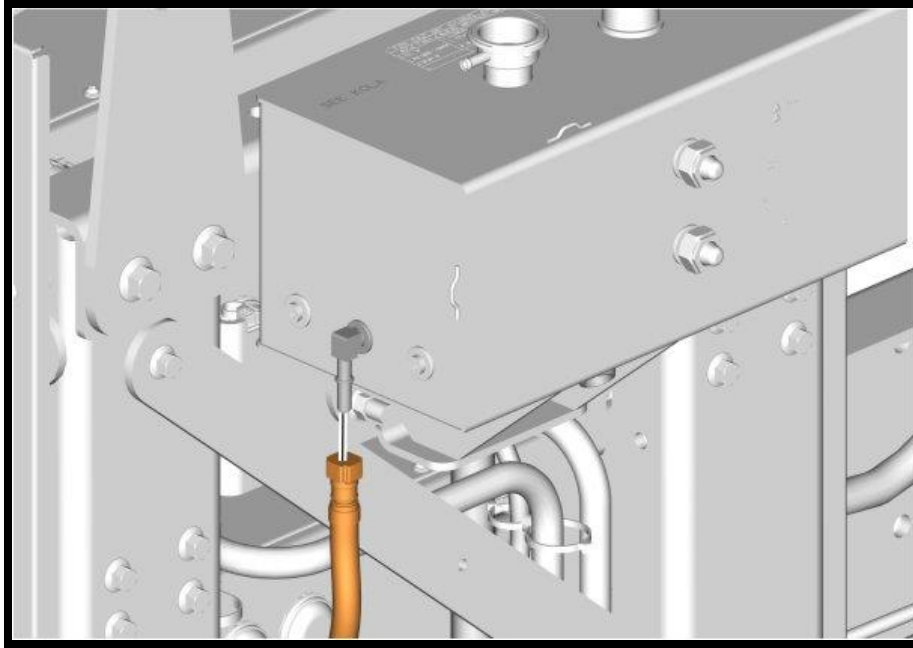

145. Install the hose.

146. Connect the connector.

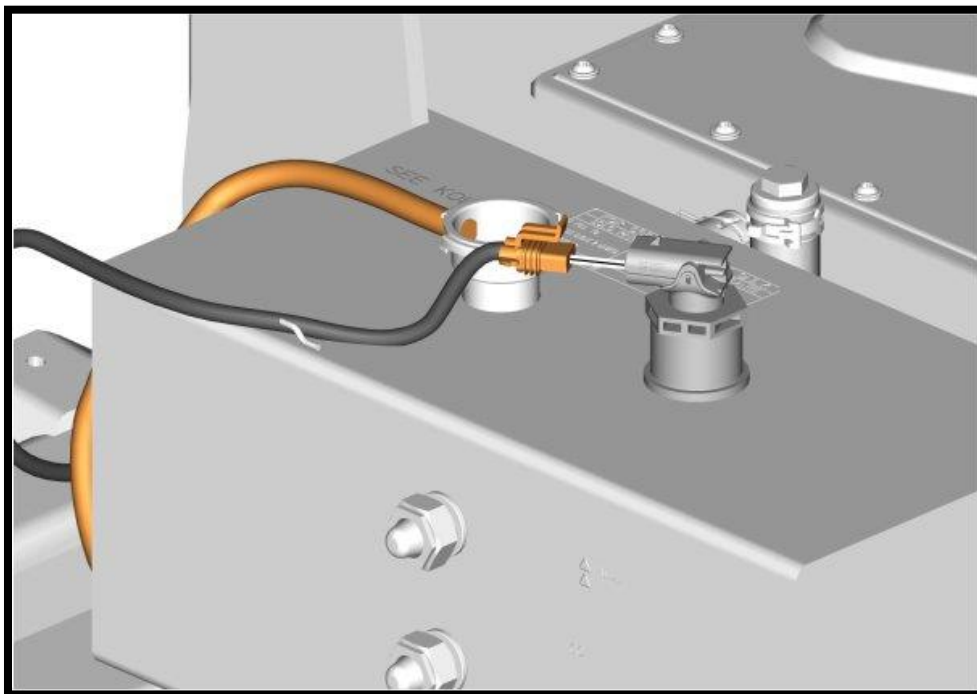

147. Install the cable ties.

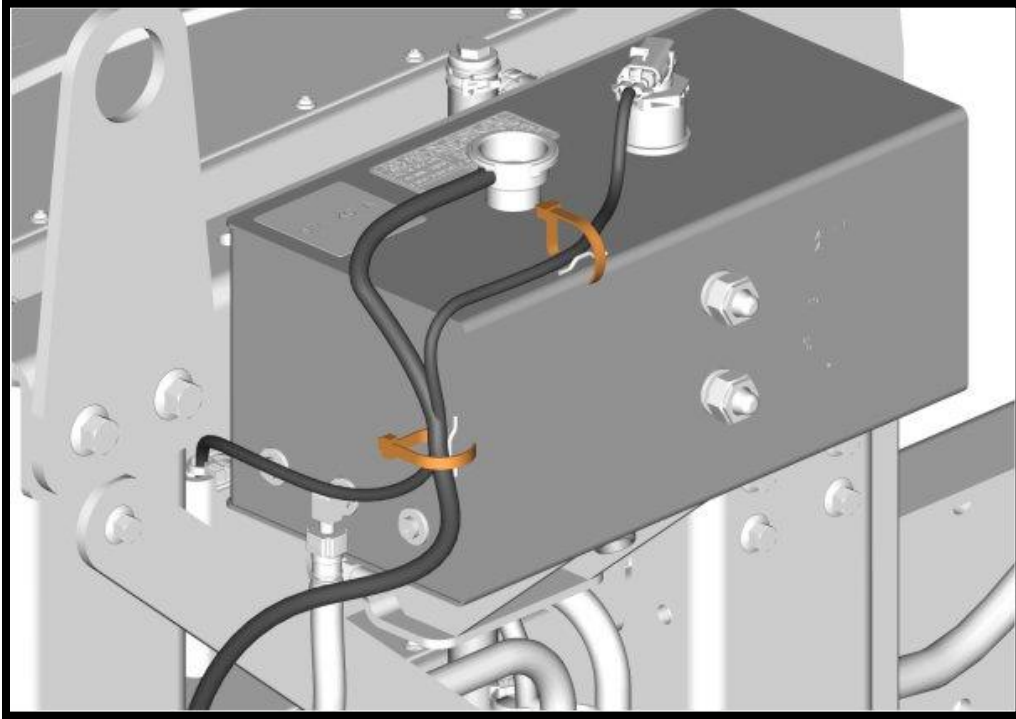

148. Install the hose.

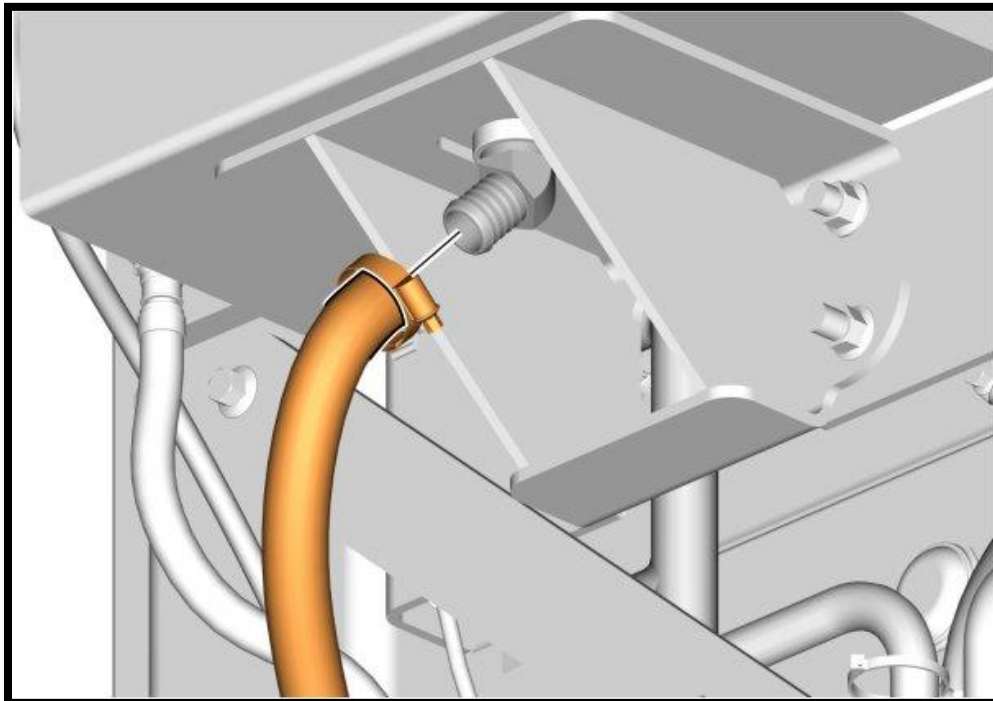

149. Tighten the clamp.

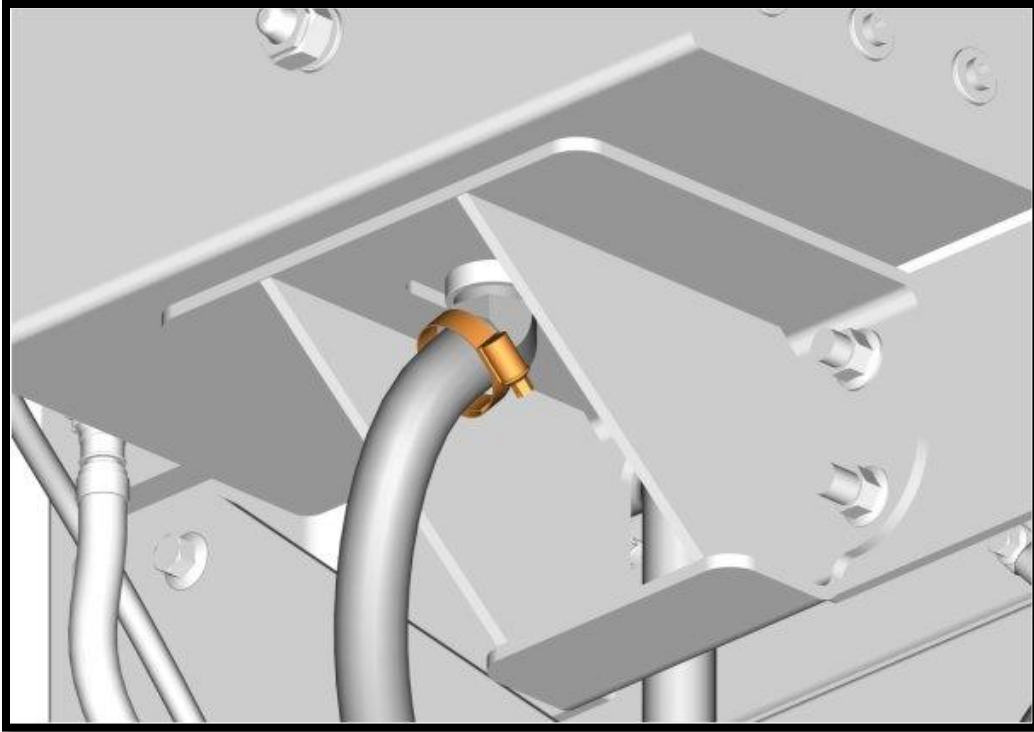

150. Install the braces.

151. Install the screws and nuts.

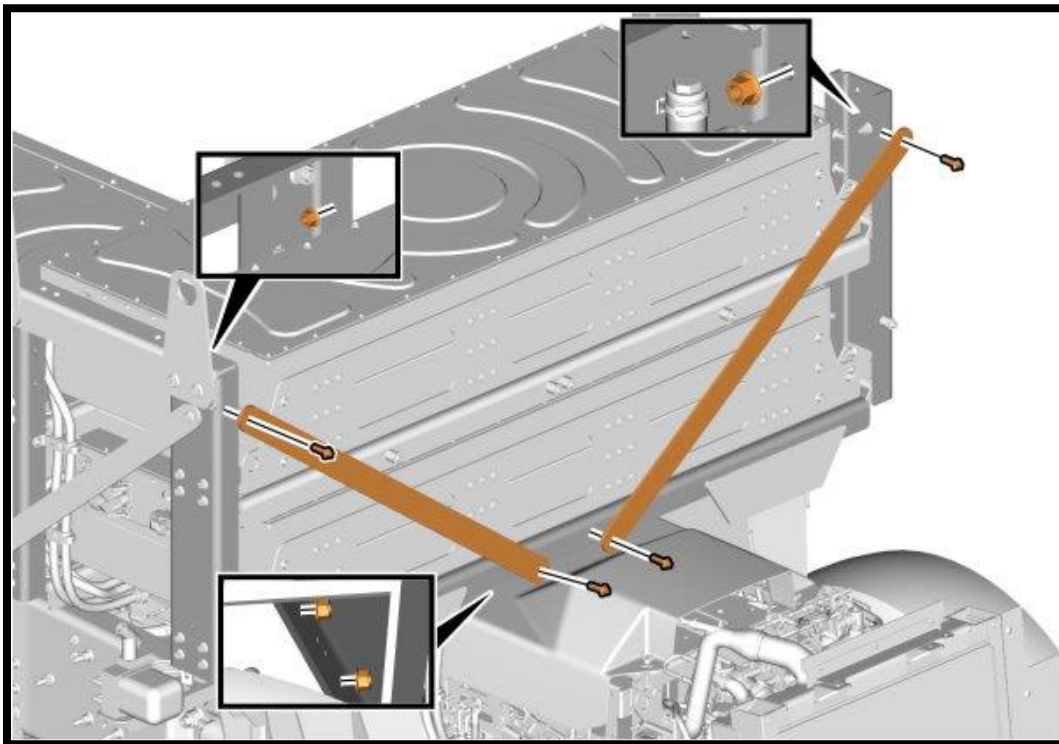

- 152. Install the braces.
- 153. Install the screws and nuts.

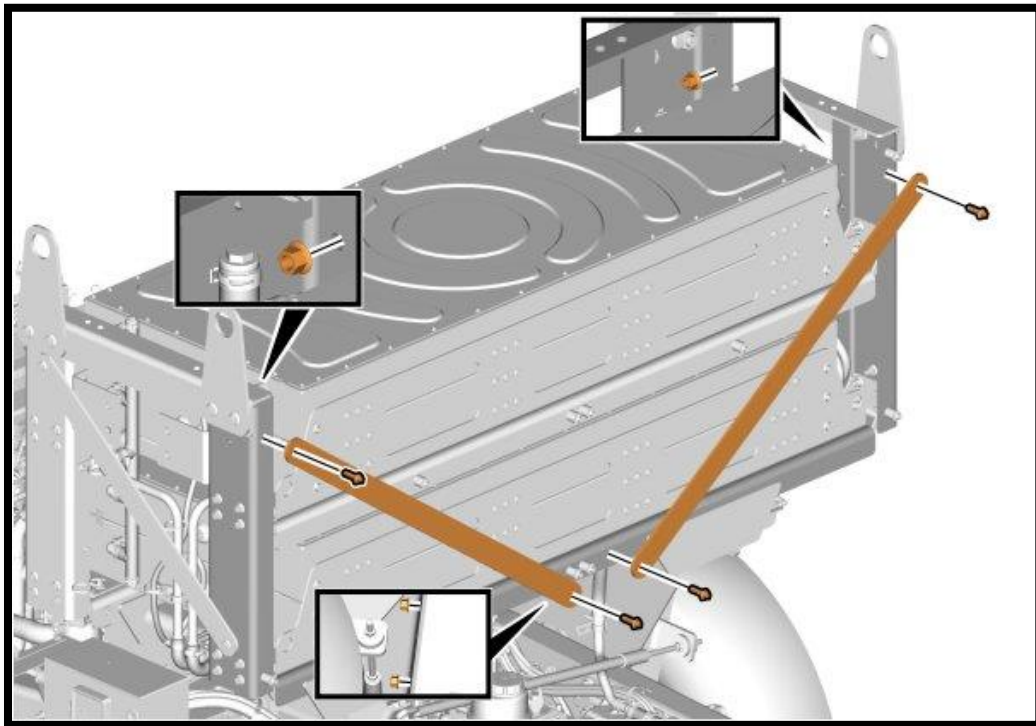

- 158. Install the shield
- 159. Install the screws.

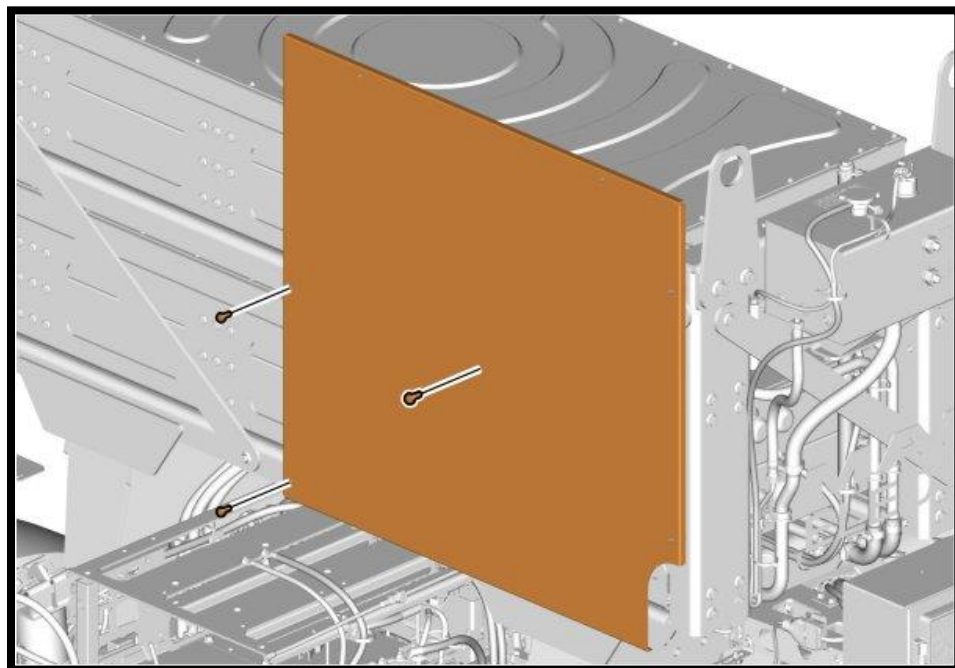



160. Install the shield

161. Install the screws.

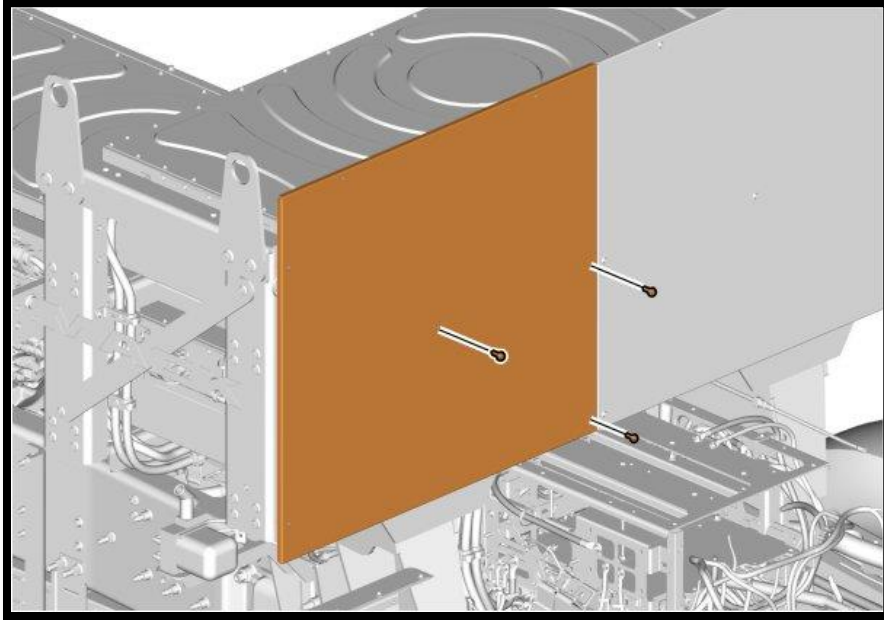

162. Install the shield

163. Install the screws.

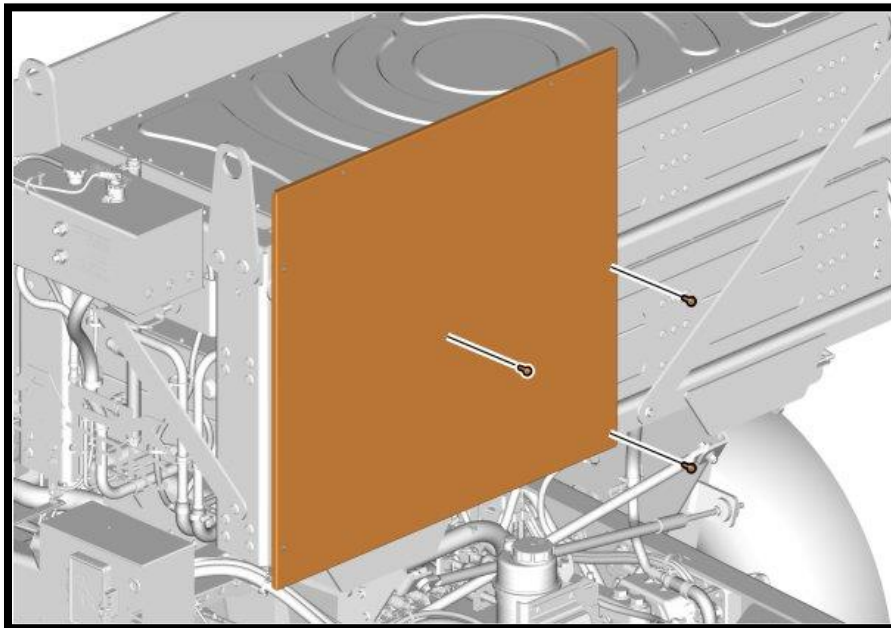

- 164. Install the shield
- 165. Install the screws.

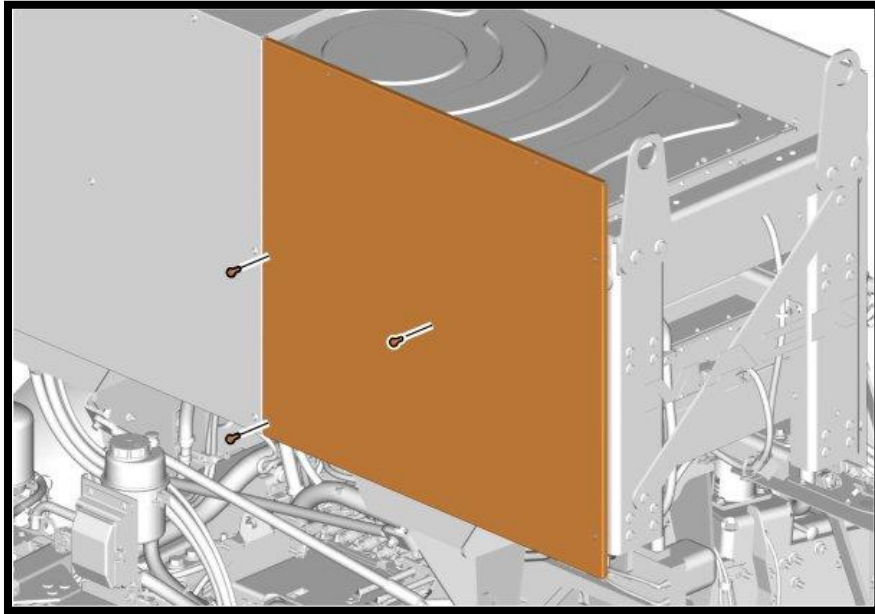

- 166. Install the shield
- 167. Install the screws.

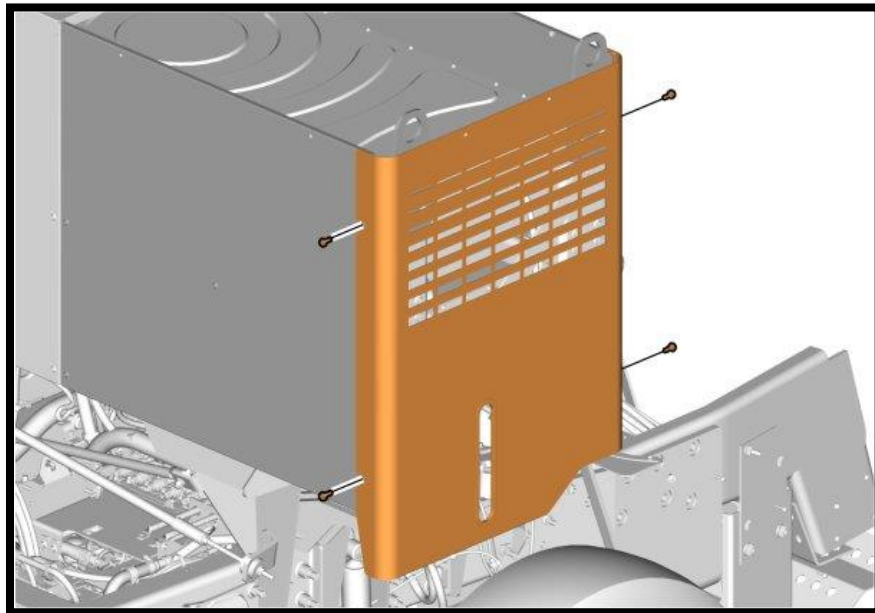

- 168. Install the shield
- 169. Install the screws.

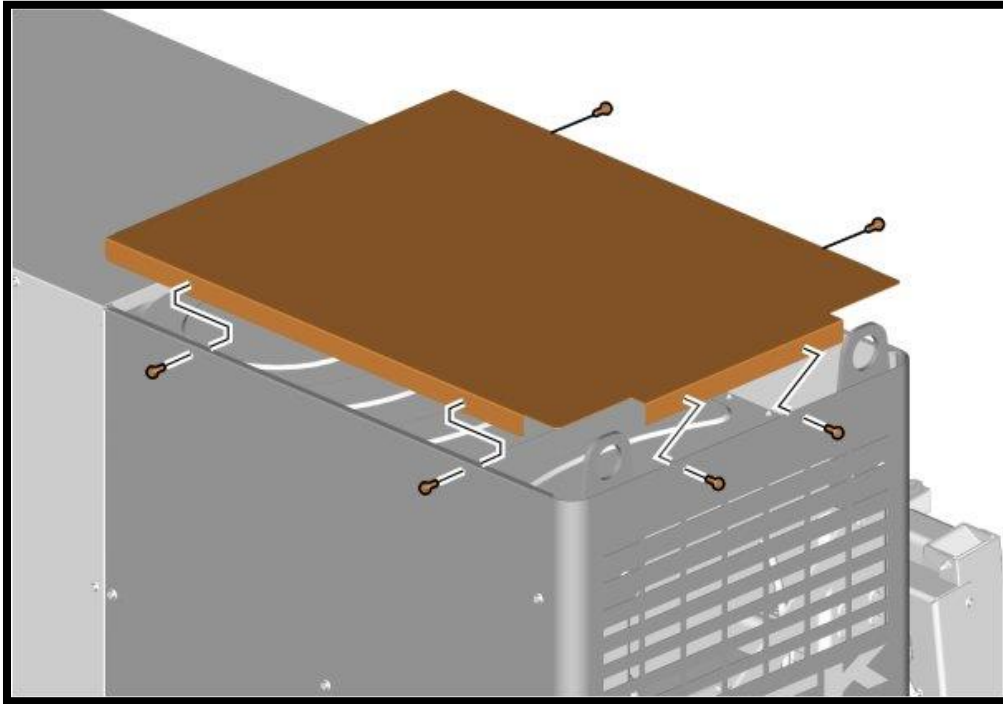

- 158. Install cable ties.

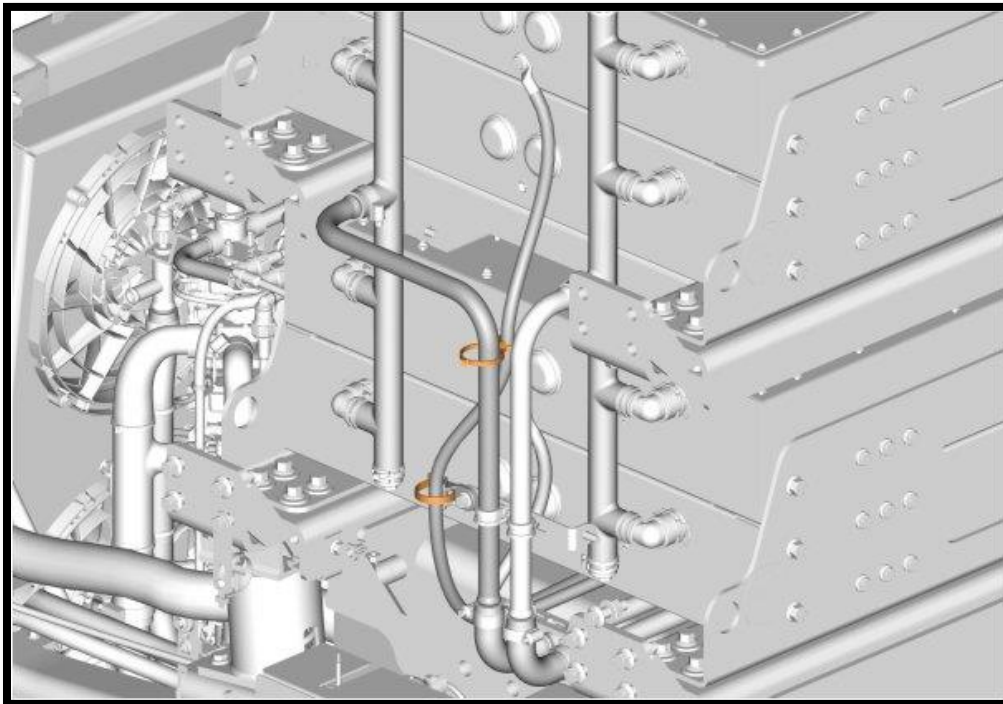

- 159. Install the shield
- 160. Install the screws.

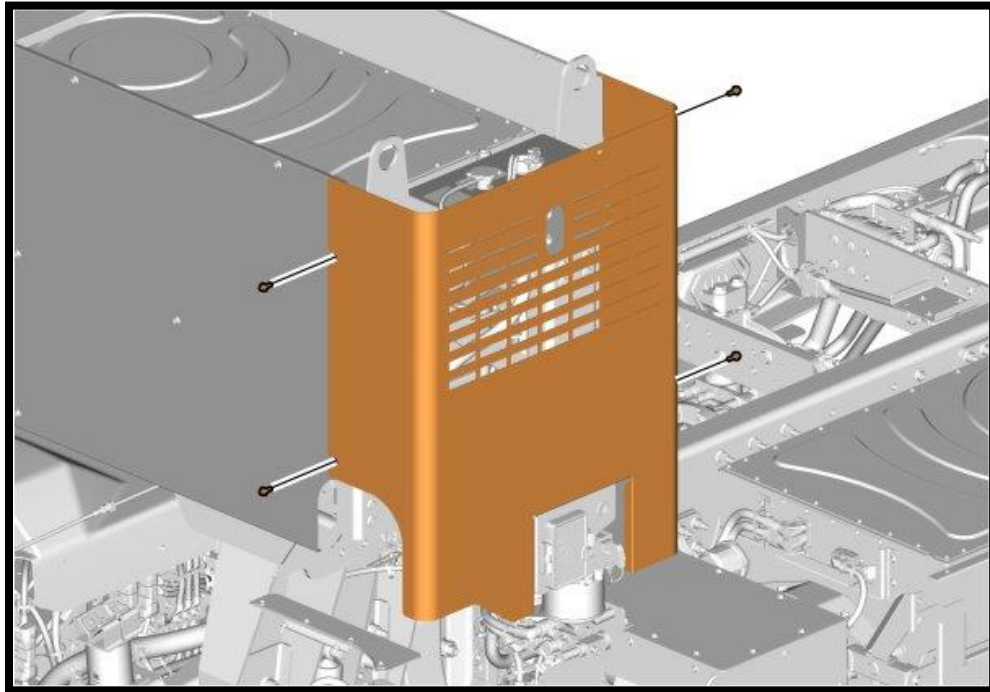

- 158. Unlock the negative terminal along with the fuses.

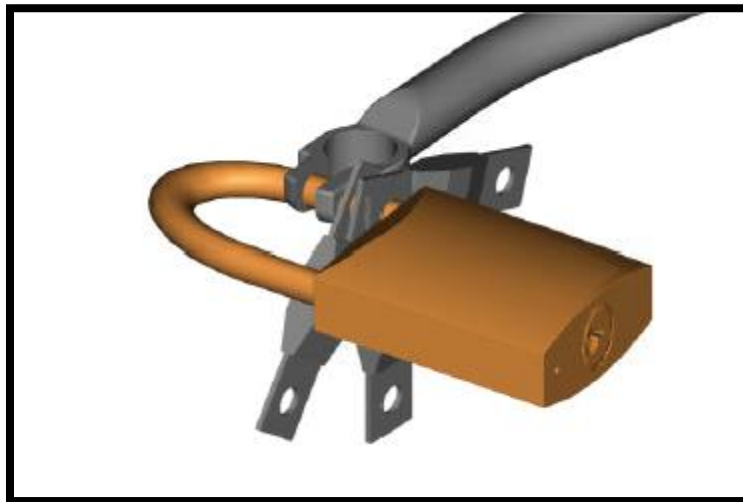

159. Remove the plug.

Required material	
PLUG	975827

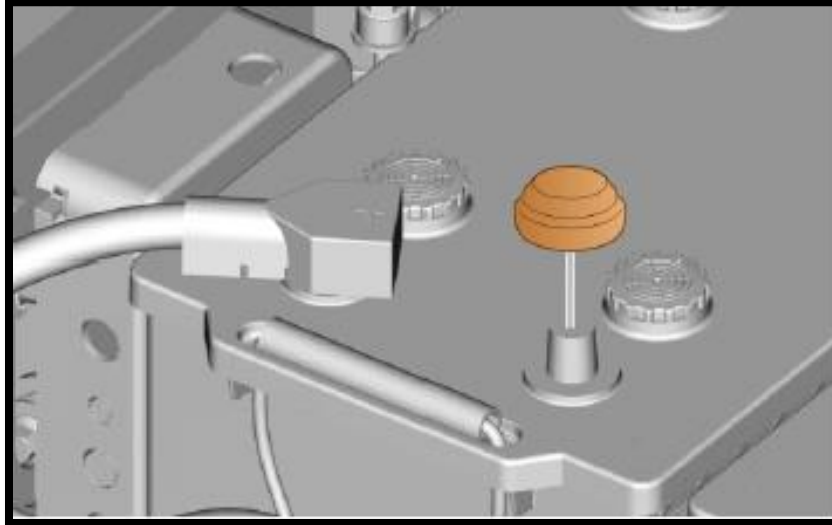

158. Connect the cable to the negative terminal. Torque tighten the nut.

Tightening torque	
Battery terminal, nut	20 $\pm$ 2 Nm (15 $\pm$ 1 lb <sub>f</sub> ft)

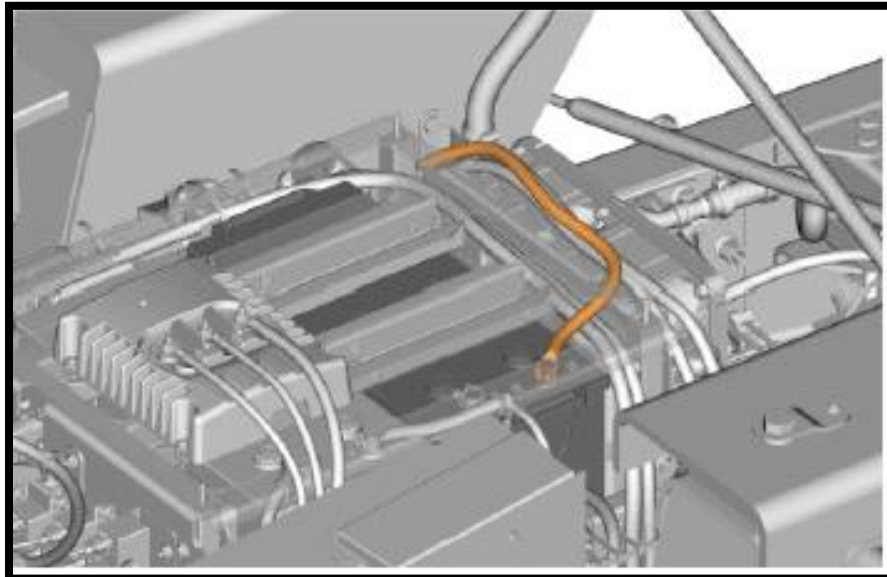

159. Install the fuses. Install the nuts. Torque tighten the nuts.

Tightening torque	
Fuse, nut	15 ±3 Nm (11 ±2 lb <sub>r</sub> ft)

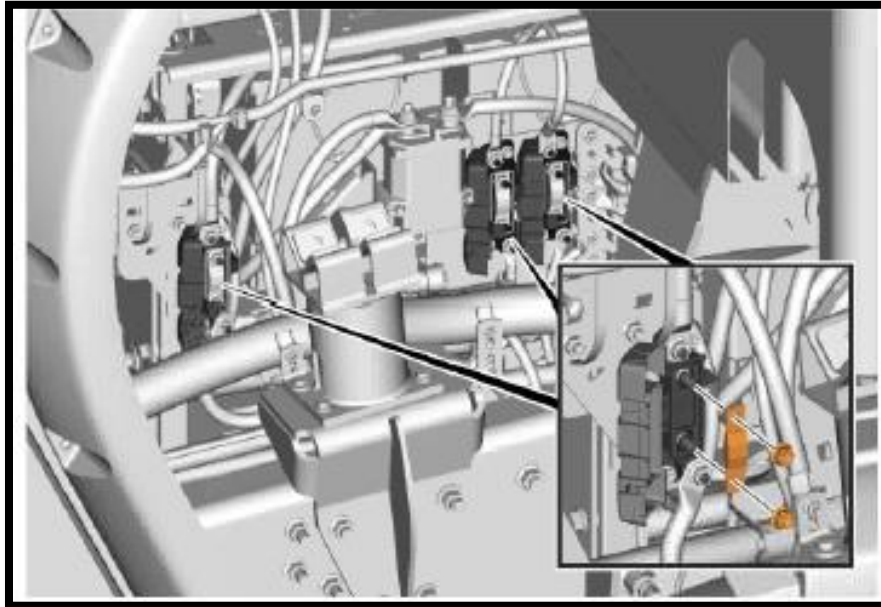

160. Install the covers. Lock the clips.

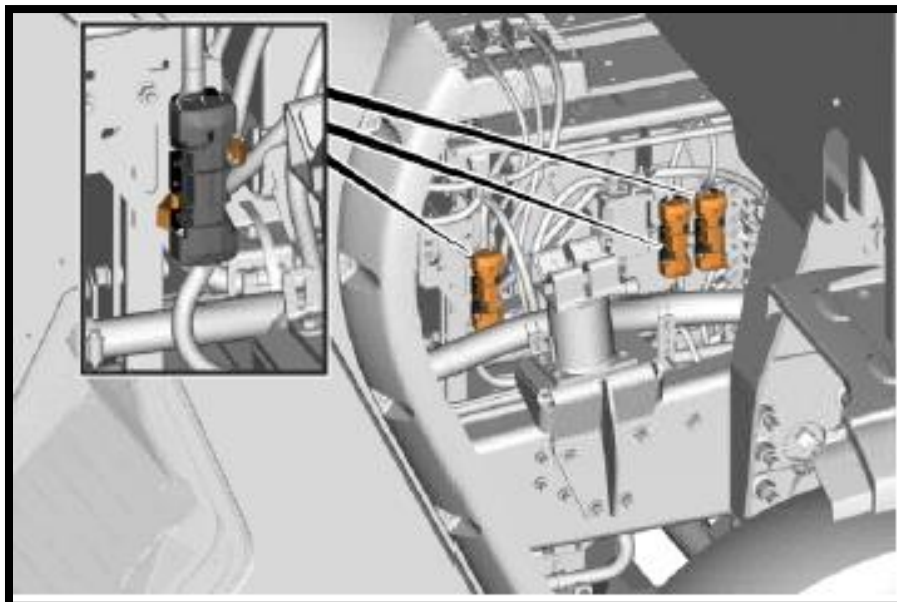

161. Connect the low voltage ESS connectors.

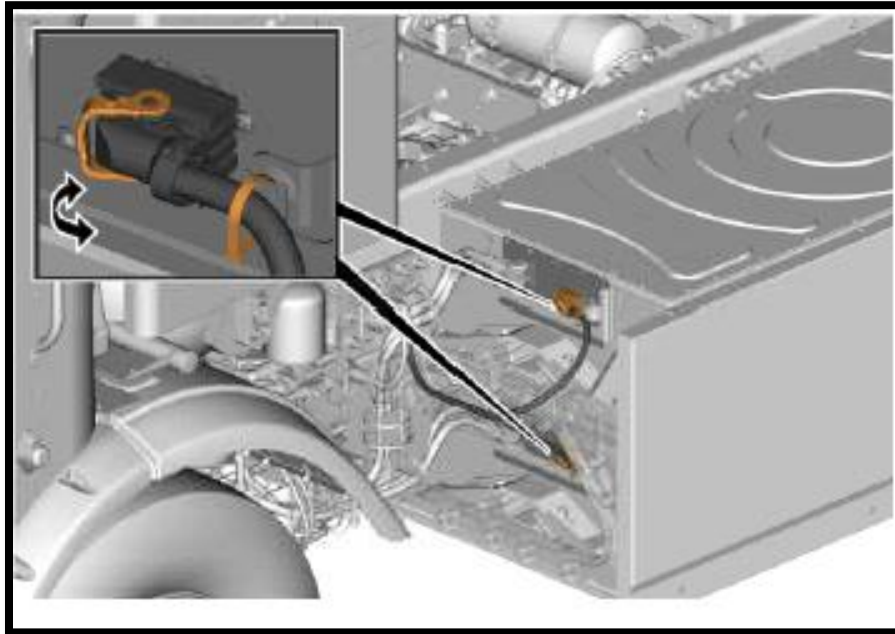

162. Connect the low voltage ESS connectors.

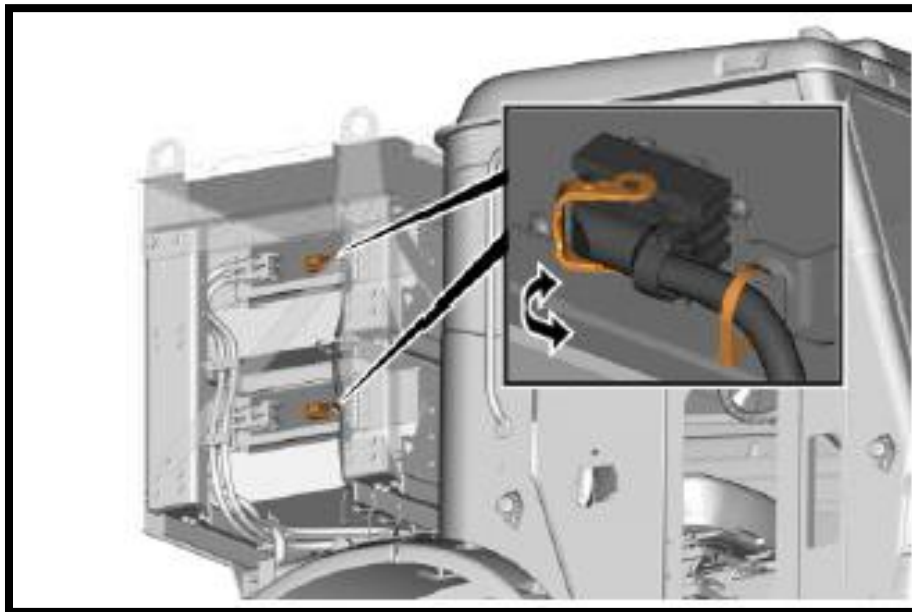

163. Remove the safety pin from the slot (B) and install in slot (A). Set the chassis switch to position (2).

**Switch, position**

Position	Status
1	OFF
2	ON

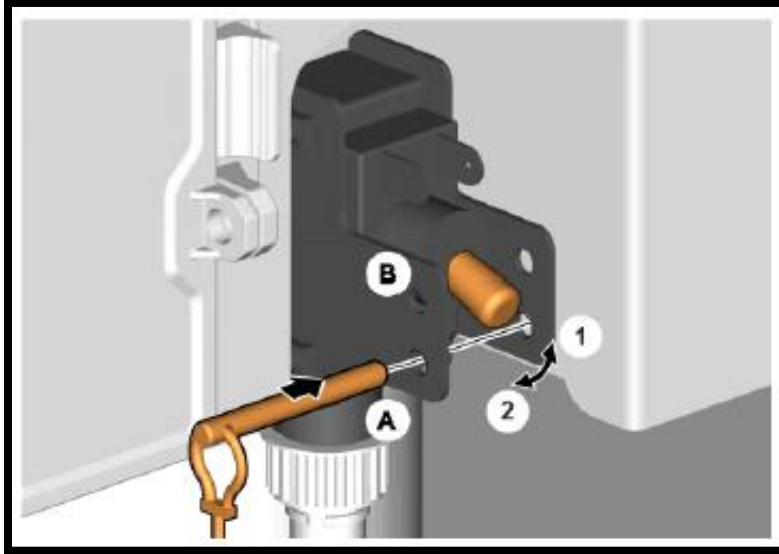

158. Disconnect the rear coolant pump.

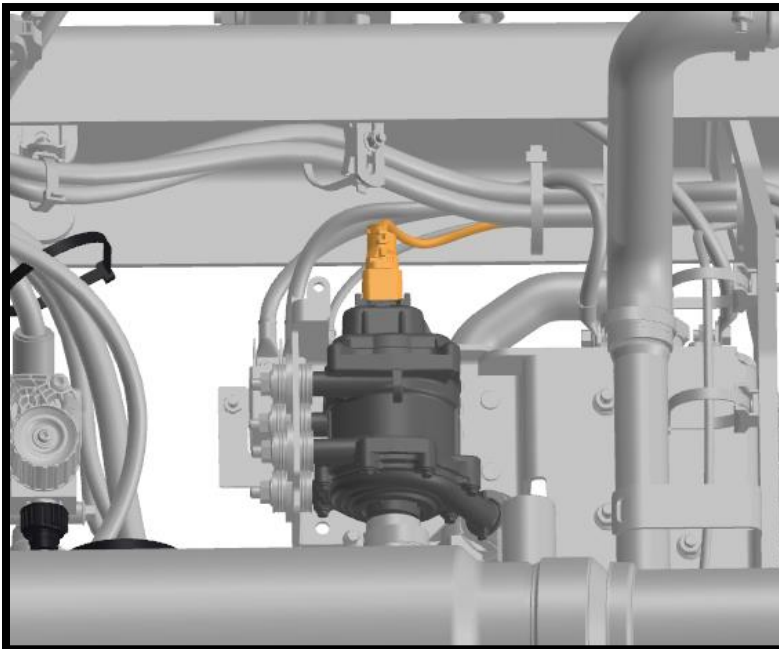



159. Disconnect the cooling box connector.

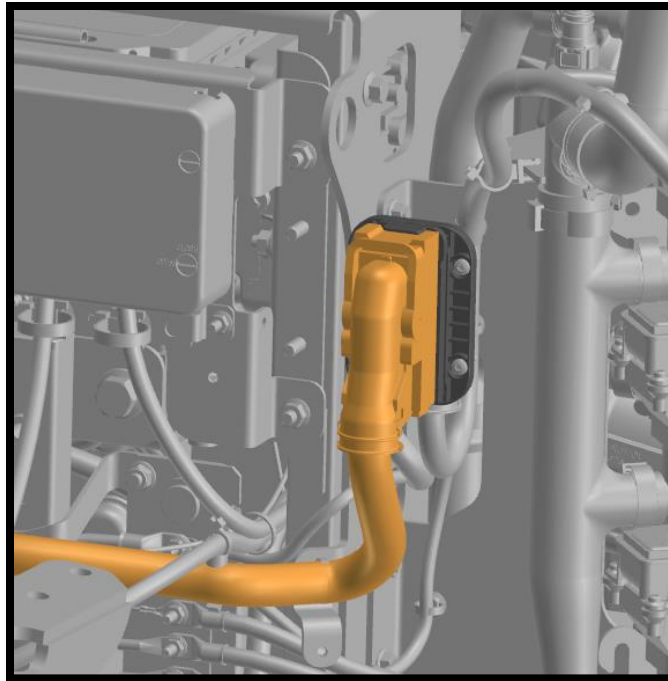

160. On MPB side of the cooling box interface connector, jump **Pin 56 to Pin 54** and **Pin 55 to Pin 53** using two short pieces of wire.

WIRE	PIN1		PIN2
EP4LB	56	JUMP TO	54
EP4HB	55	JUMP TO	53

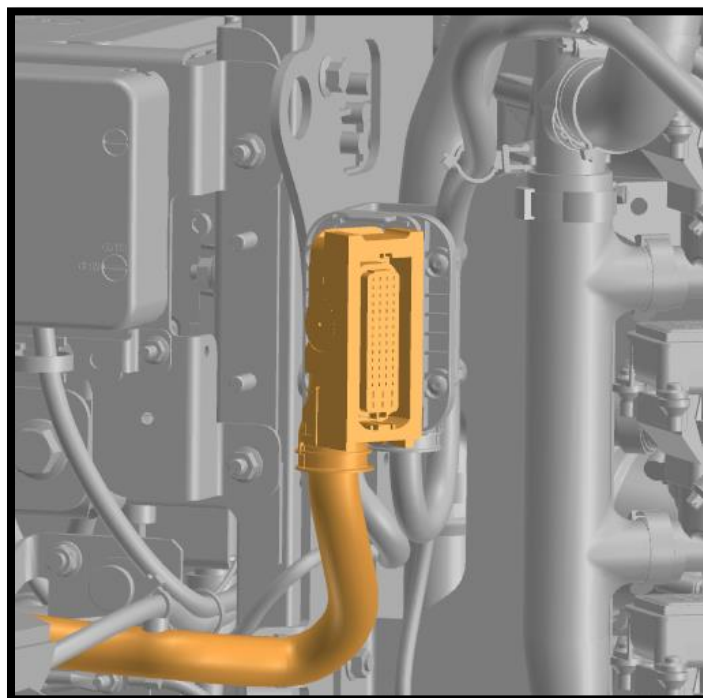

161. Fill the coolant extractor.

Required material	
COOLANT EXTRACTOR/INJECTOR	85112740
➡ Coolant	



158. Position a draining container. Remove the plug.



159. Install the tool

<b>Required material</b>	
COOLANT EXTRACTOR/INJECTOR	85112740

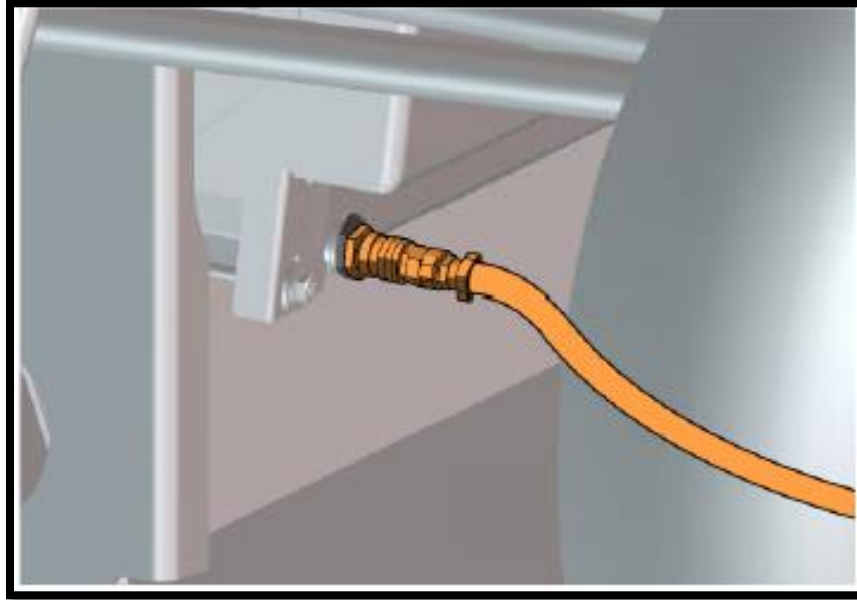

158. Loosen the bleeder screws.

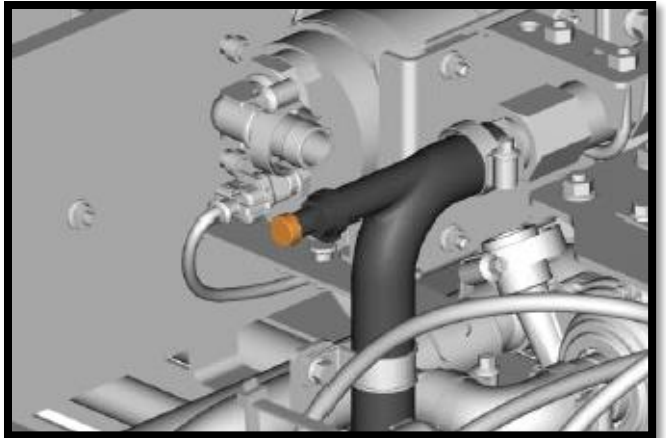
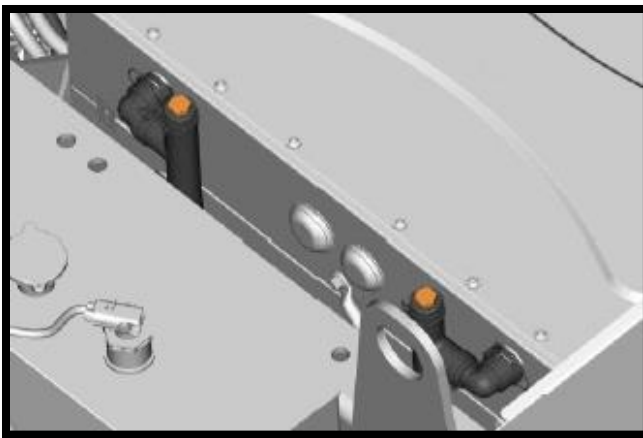
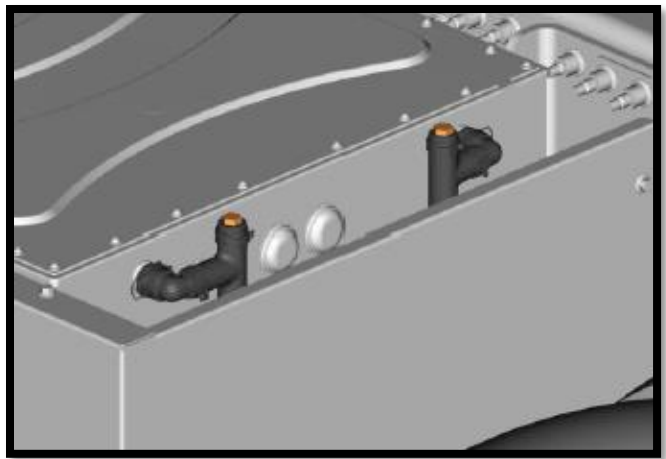
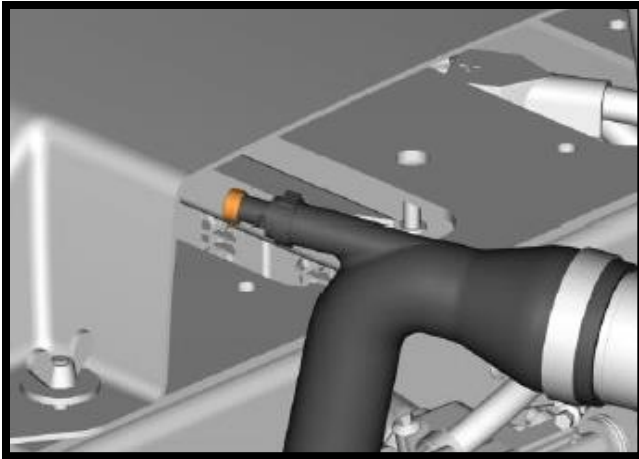

159. Set the 3-way valves to position 2.

Position	Status
1	Closed
2	Half Open
3	Fully open

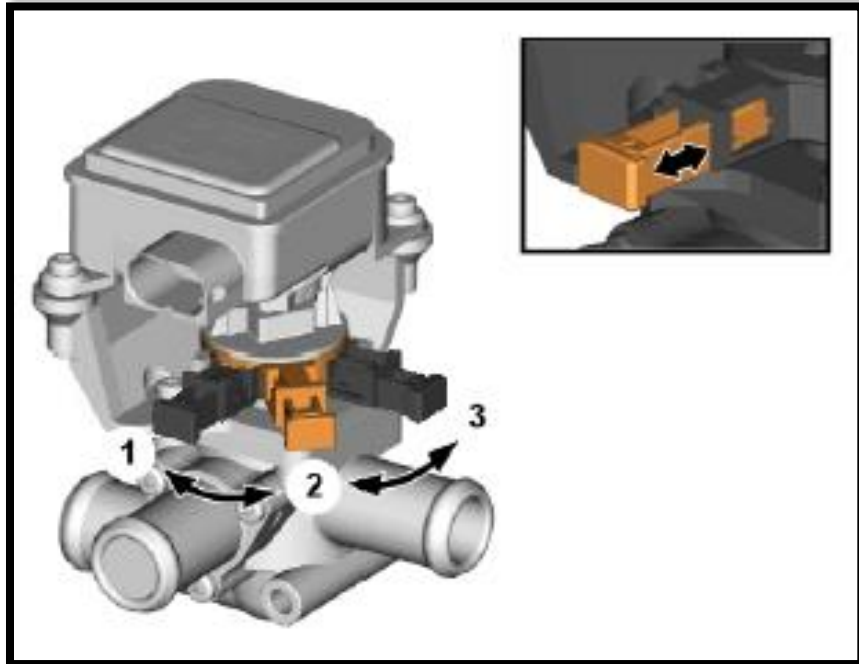

158. Connect the diagnostic tool. Check for internal ESS isolation faults.



159. Navigate to 3711-08-03-02 Wiggle Wire test.

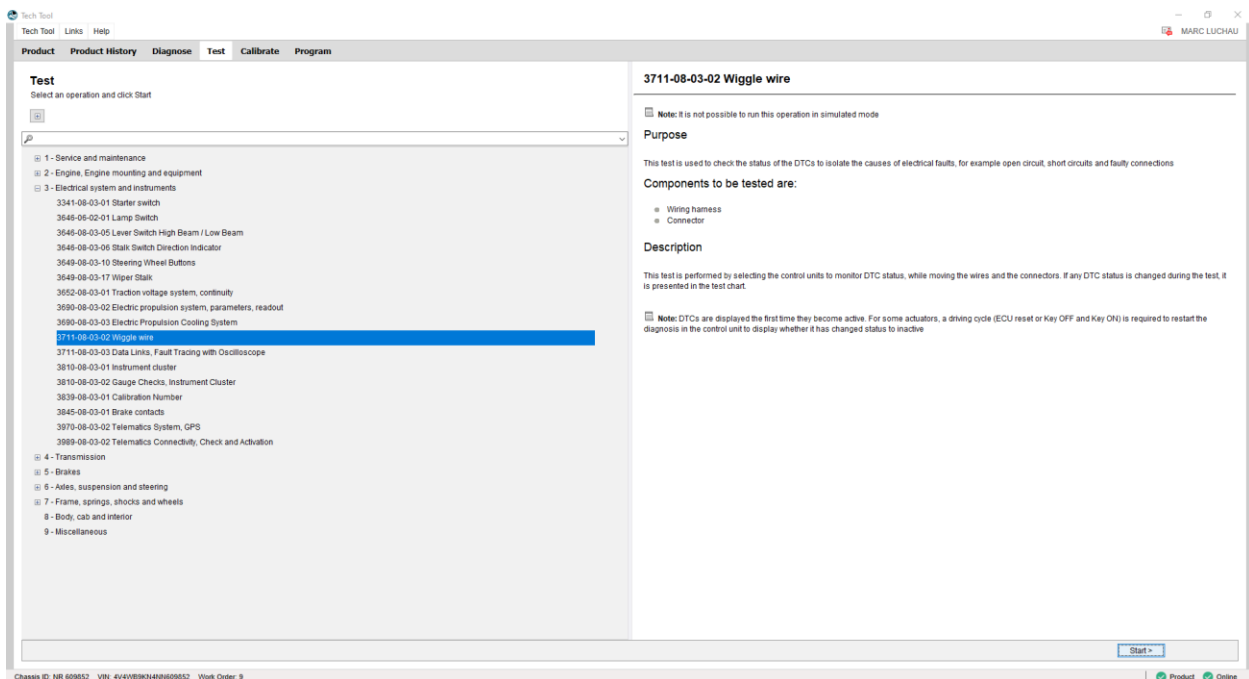

160. Select ESCM from ECU list.

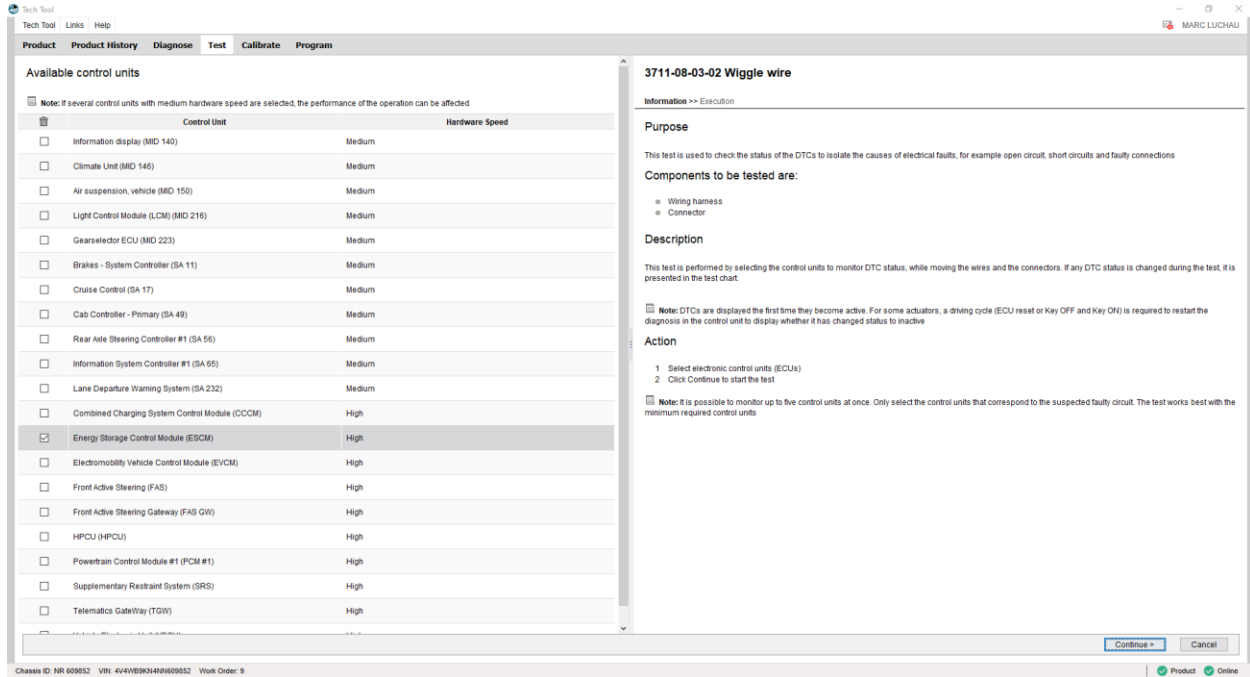

161. Press play. Codes will be present due to the partial commission state.

Monitor the test for these codes during initial coolant fill:

- Battery 1 circuit resistance below threshold P1025-1A
- Battery 2 circuit resistance below threshold P1026-1A
- Battery 3 circuit resistance below threshold P1027-1A
- Battery 4 circuit resistance below threshold P1028-1A

**Required material**

☛ Coolant



**Note**

Fill gradually to obtain good degassing.



**Note**

Coolant will flow from the bottom up, starting from the lowest position.

**IF ESS isolation faults are set during fill, stop work, exit the building, and contact the fire department.**

162. Tighten the bleeder screws.



**Note**

Close the screws as soon as the coolant flows.

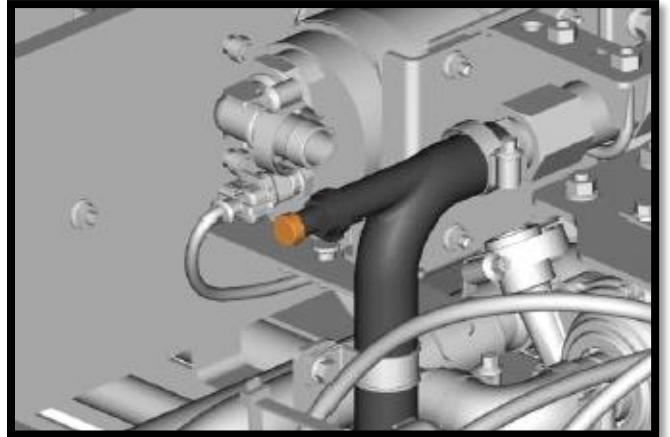
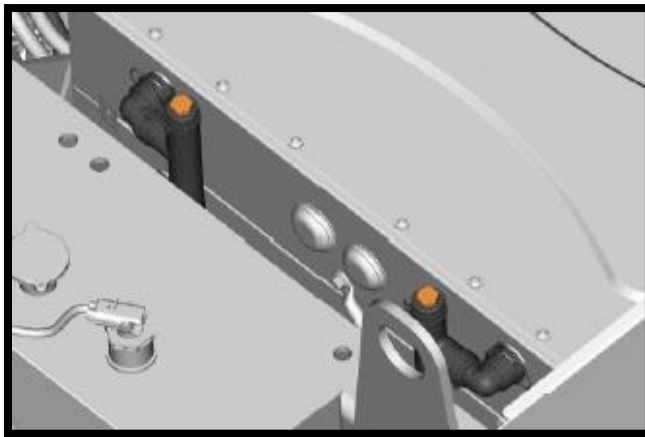
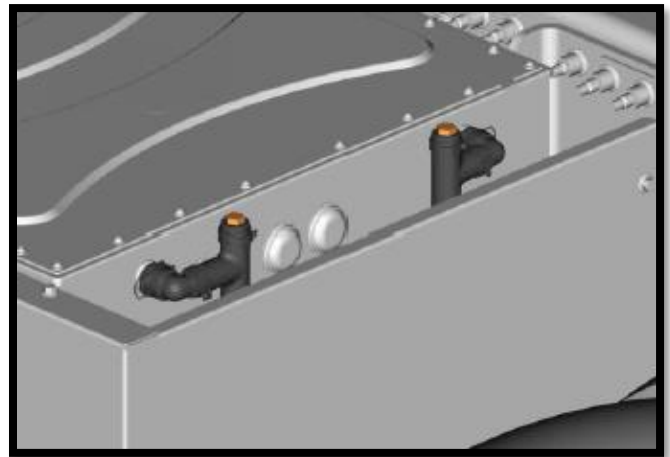
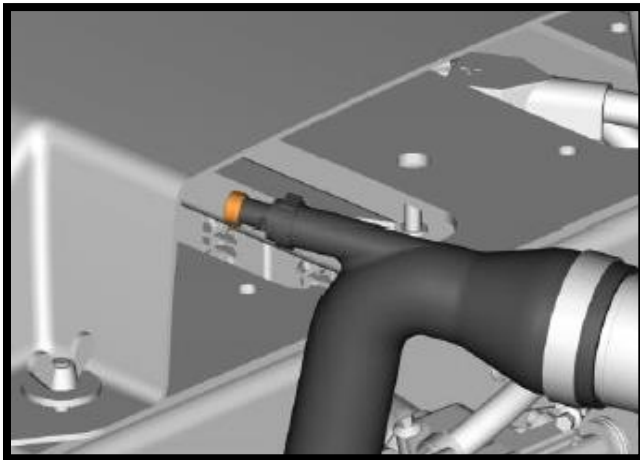



163. Reconnect the coolant pumps. Remove the jumper and connect the connector.

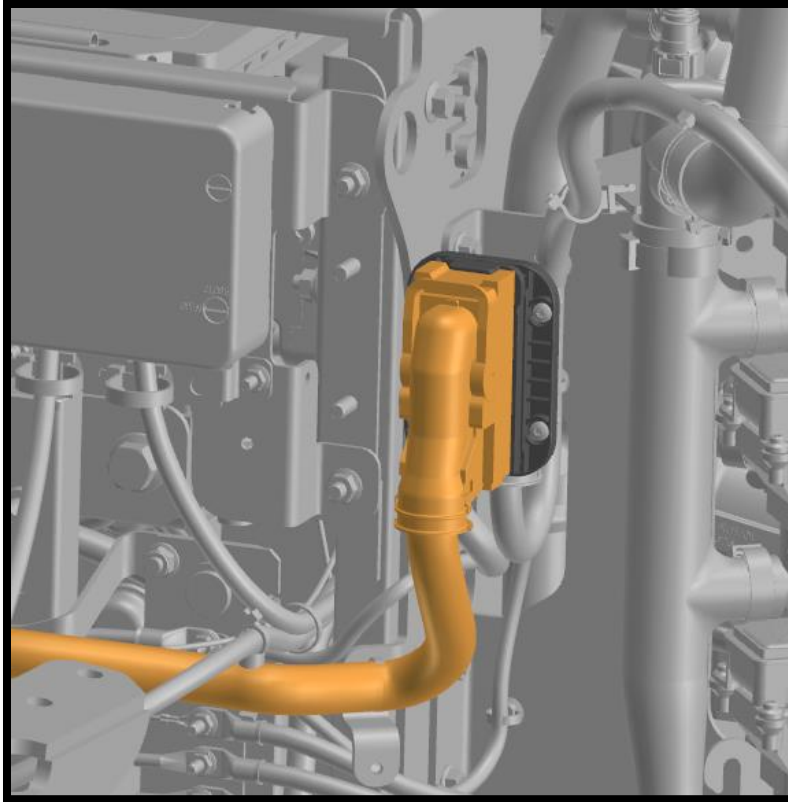

164. Connect the rear coolant pump.

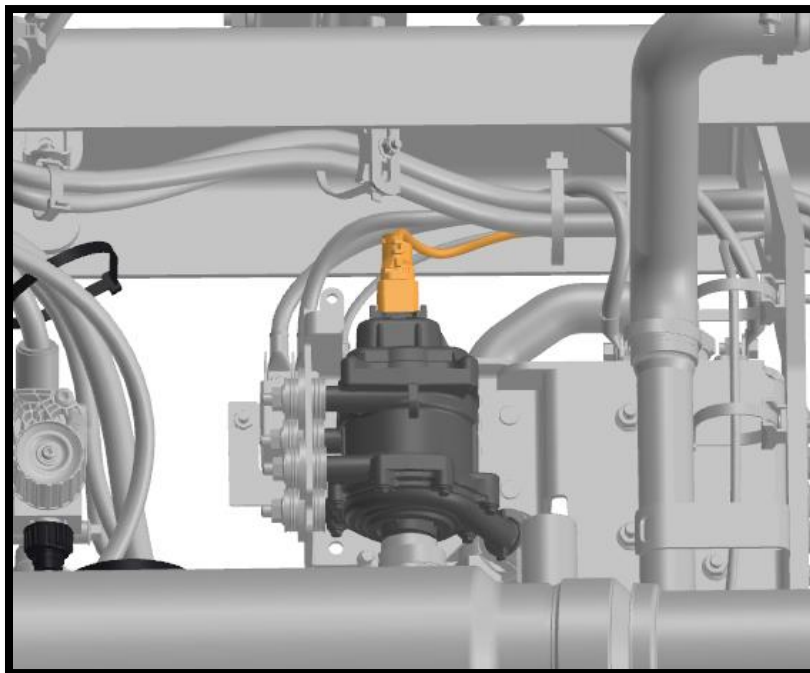

158. Set the 3-way valves to position 1.

Position	Status
1	Closed
2	Half Open
3	Fully open

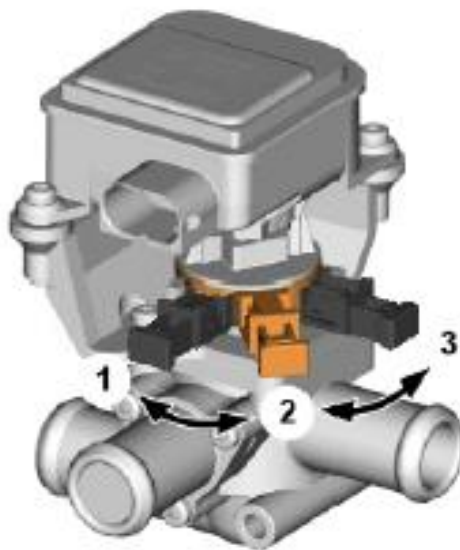
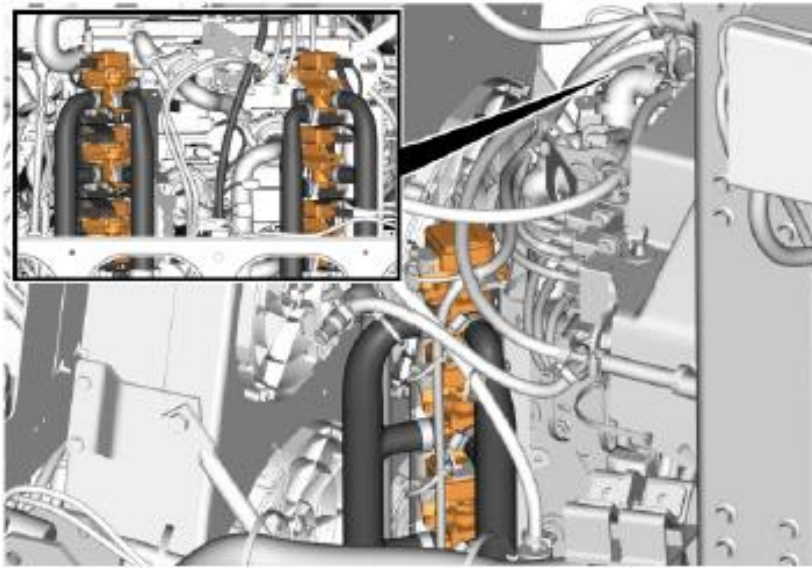

159. Perform “Electric driveline cooling system, bleeding” in PTT.

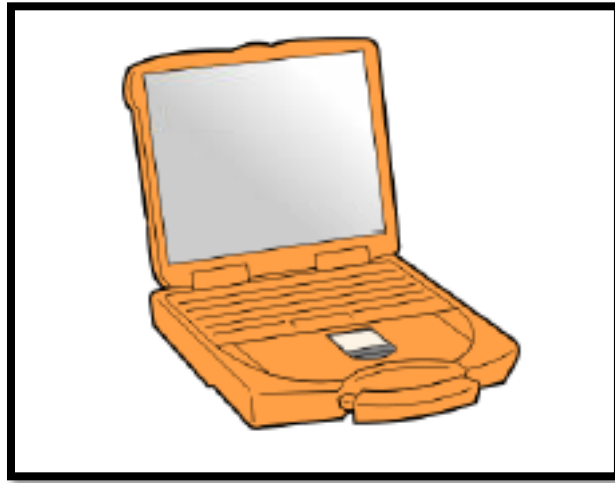

160. Loosen the bleeder screw.

161. Tighten the bleeder screw as soon as coolant flows.

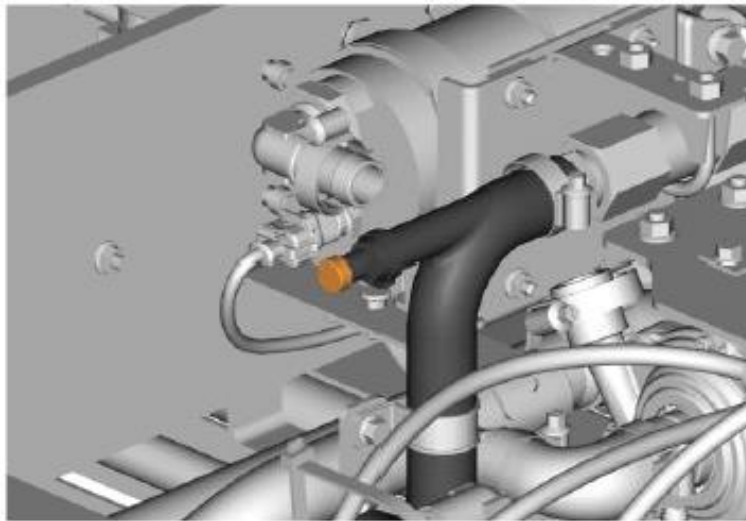

162. Loosen the bleeder screw.

163. Tighten the bleeder screw as soon as coolant flows.

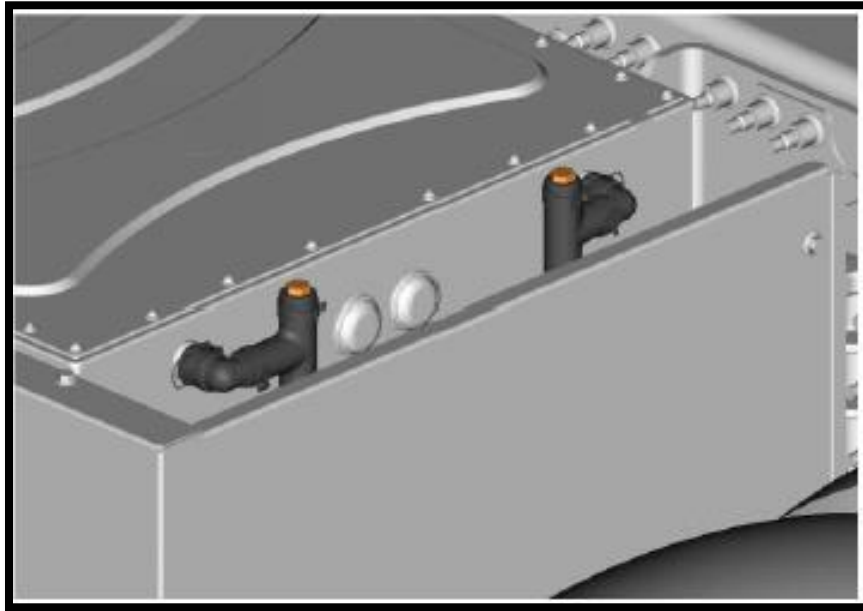

164. Loosen the bleeder screw.

165. Tighten the bleeder screw as soon as coolant flows.

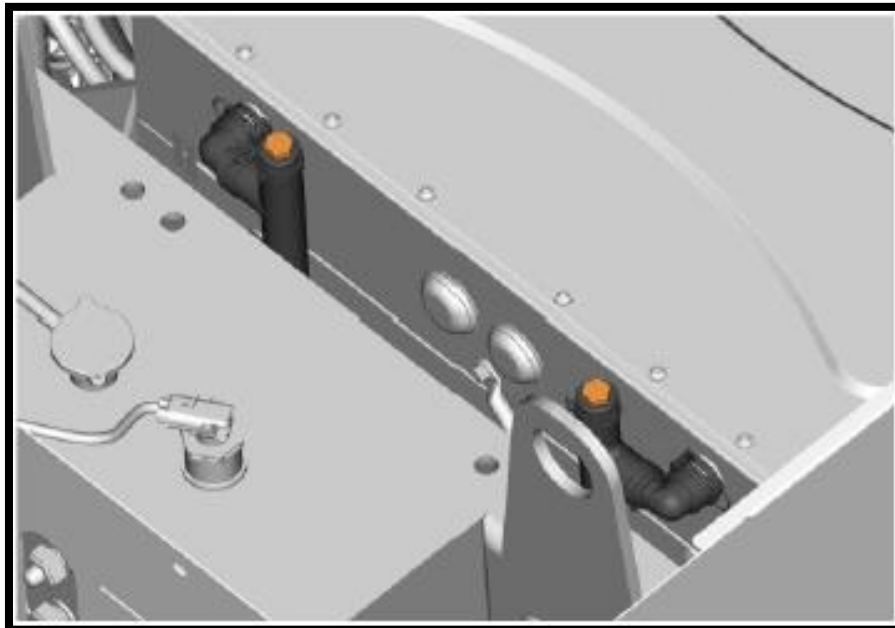

166. Loosen the bleeder screw.
167. Tighten the bleeder screw as soon as coolant flows.

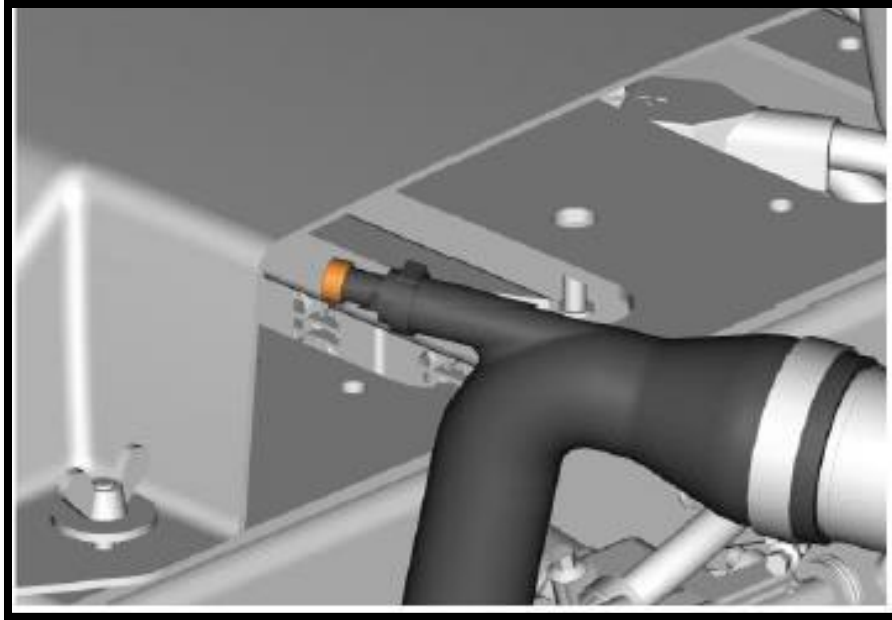

168. Check the coolant level. Adjust as necessary

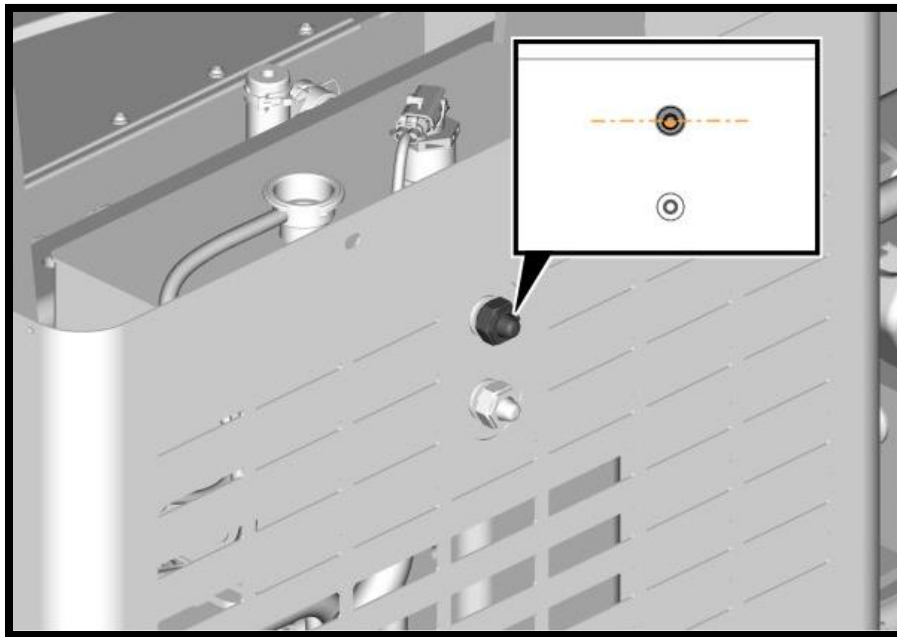

169. Remove the safety pin from the slot (A) and install in slot (B). Set the chassis switch to position (1)

**Switch, position**

Position	Status
1	OFF
2	ON

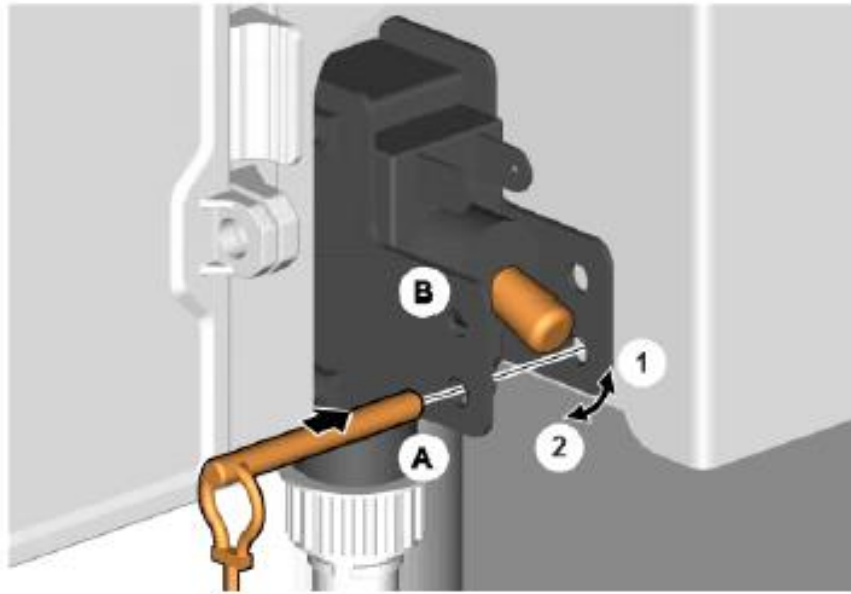

158. Disconnect the low voltage ESS connectors.

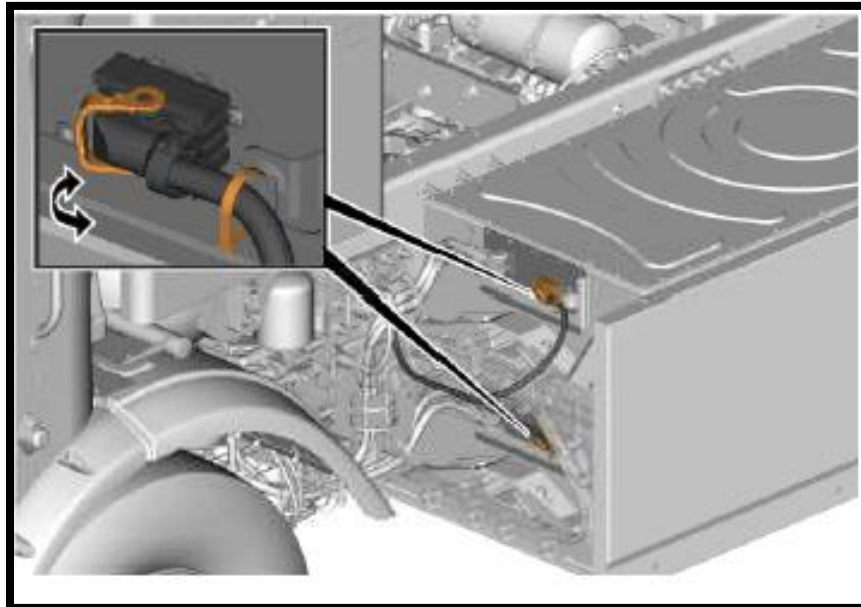

159. Disconnect the low voltage ESS connectors.

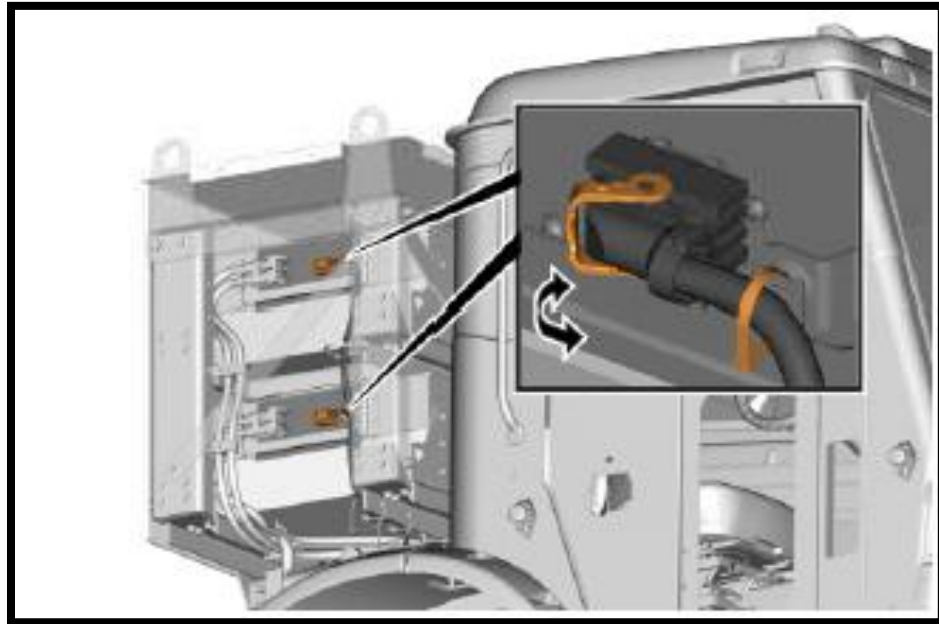

160. Remove the covers.

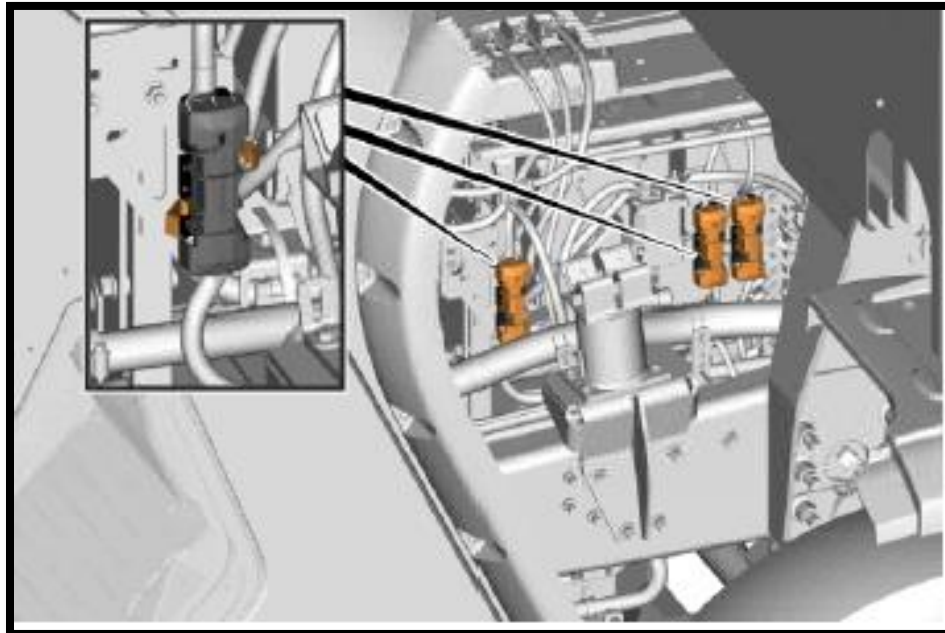

161. Remove the fuses.

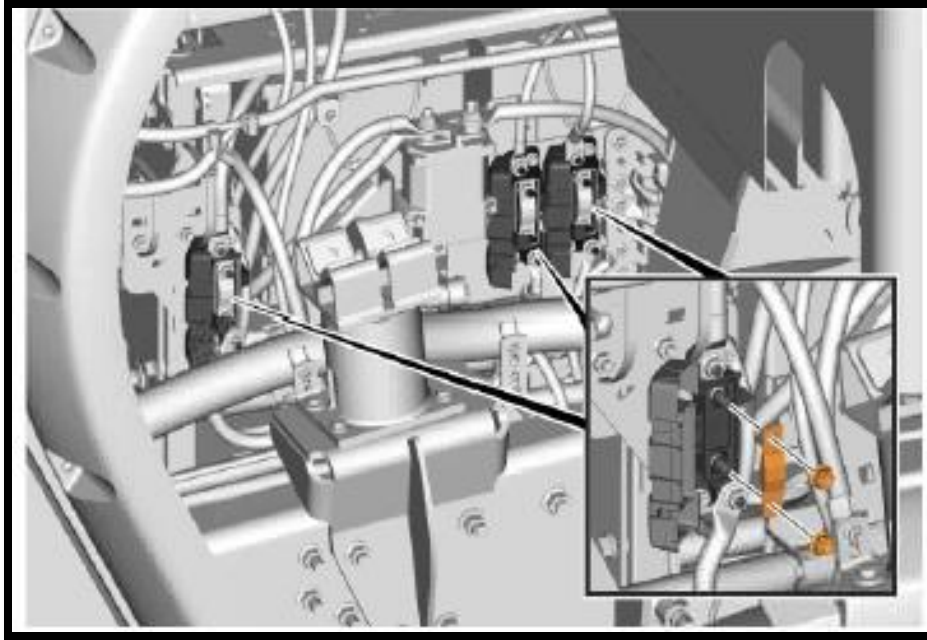

162. Disconnect the cable to the negative terminal.

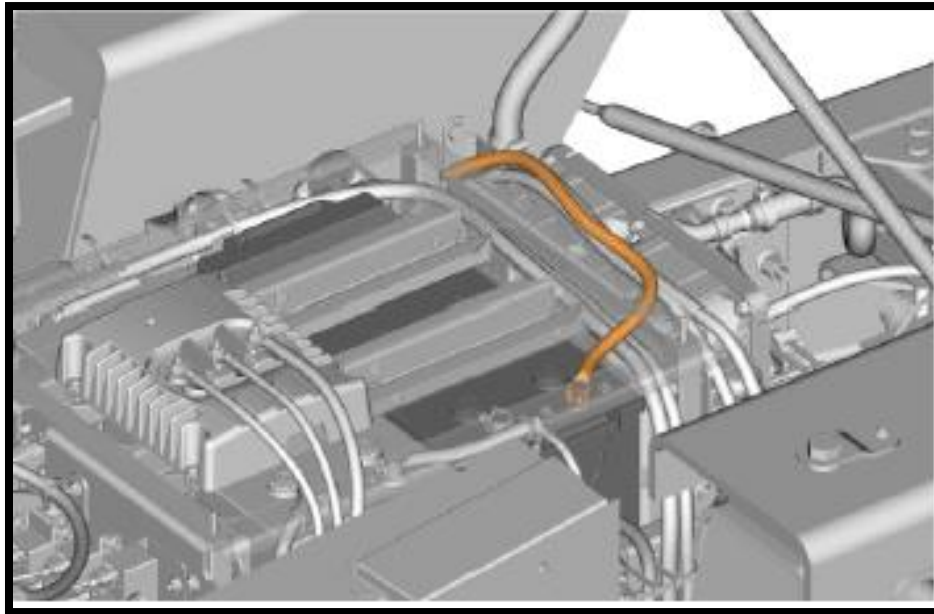



163. Unlock the negative terminal along with the fuses.

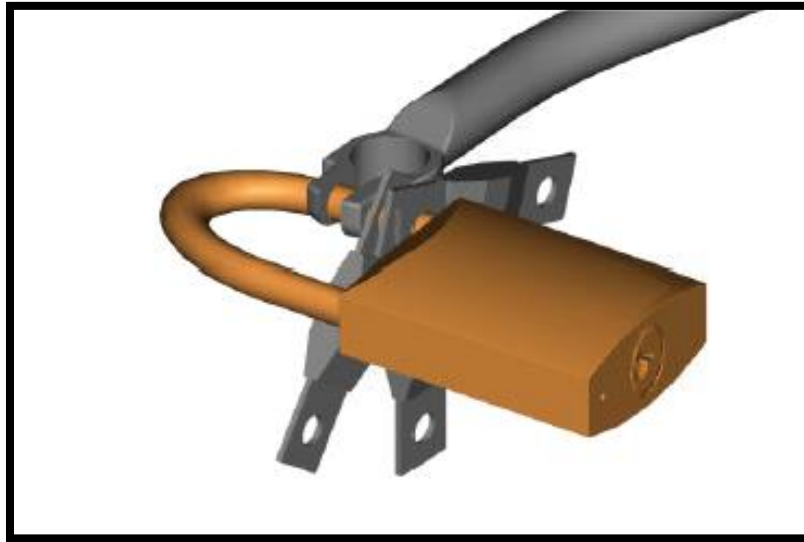

164. Install the plug.

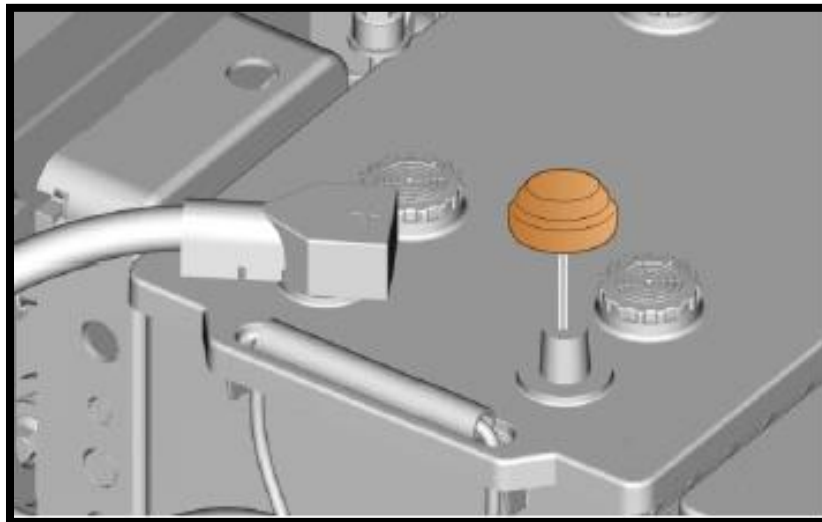



165. Follow Impact Operation 3100-09-01-03 Traction Voltage System Commissioning.
166. Print and fill out worksheet at the end of this document and have it uploaded to the warranty case.
167. Return truck to service.

## Battery Return Process

To return removed Akasol ESS battery pack. The following RMA process will need to be completed.

- All batteries need to be packaged in the same packaging that the replacement battery was delivered in, unless the battery has been deemed defective in which case, please refer to Battery Storage and Transport in Impact.
- Please remove or cover the replacement battery serial number from the packaging and clearly record return battery serial number on the outside of the packaging.
- One RMA sheet must be filled per return trailer load (**NOT** per truck). Please fill out RMA sheet using excel (do **NOT** print and fill out). Follow example sheet below to complete the RMA.
- A return trailer load can vary in size from 6 to 24 depending on your locations repair quantity and type of battery crate being used. For return trailer loading instructions please see chart below.
- Once RMA sheet is complete, please send an email to the following addresses [ELI@evansdist.com](mailto:ELI@evansdist.com), [tbeauchesne@borgwarner.com](mailto:tbeauchesne@borgwarner.com), and CC [campaign@volvo.com](mailto:campaign@volvo.com) to schedule a battery return pickup. Please include the following in the email.
  - Attach RMA sheet.
  - Dealer name and address.
  - Number of batteries being returned.
  - Point of contact.
  - Pick-up days and hours.
- If you do not receive a response, please send an email to [campaign@volvo.com](mailto:campaign@volvo.com).



Battery Crate Types	
TYPE ONE	TYPE TWO
<ul style="list-style-type: none"><li>• <b>Can</b> be stacked</li><li>• 24 per trailer load max</li><li>• Can be mis-matched with type two but can only be stacked with like type.</li></ul> 	<ul style="list-style-type: none"><li>• <b>CANNOT</b> be stacked</li><li>• <b>18</b> per trailer load max</li><li>• Can be mis-matched with type one on load but can <b>NEVER</b> be stacked (<b>Top or Bottom</b>).</li></ul> 

**REIMBURSEMENT**

**Important Note**

Please make sure the Recall worksheet has been filled out and is uploaded to the warranty claim. Failure to do so will result in a rejected claim.

This repair is covered by an authorized safety recall. Reimbursement is obtained through the normal claim handling process.

	UHP Reimbursement
Claim Type (used only when uploading from the Dealer Business System)	40
Recall Status	
Vehicle repaired per instructions	1-Modified per instructions
<b>Main Labor Code</b>	
3121-03-03-02 Replace Batteries- All	8.0
<b>Labor Codes</b>	
3100-09-01-04 Traction Voltage Decommissioning	1.0
3100-09-01-03 Traction Voltage Commissioning	1.3
1720-16-09-01 Replacement Testing 0.1x15	1.5
Causal Part	24203806
Authorization Number	C0310

Note: Dealers are to perform this Safety Recall Campaign on all subject vehicles at no charge to the vehicle owner regardless of mileage, age of vehicle or ownership (original purchaser or subsequent purchasers). Whenever vehicles are subject to a Safety Recall are brought to your dealership for service, or taken into your dealership vehicle inventory, it is strongly recommended that every effort be made to perform the recall correction before the vehicle is sold or released to the owner.

**Print, fill out, and upload to Warranty Claim when completed.**

**SC0447 Recall Worksheet**

Date \_\_\_\_\_

Dealer \_\_\_\_\_

Technician \_\_\_\_\_

VIN# \_\_\_\_\_

Miles \_\_\_\_\_

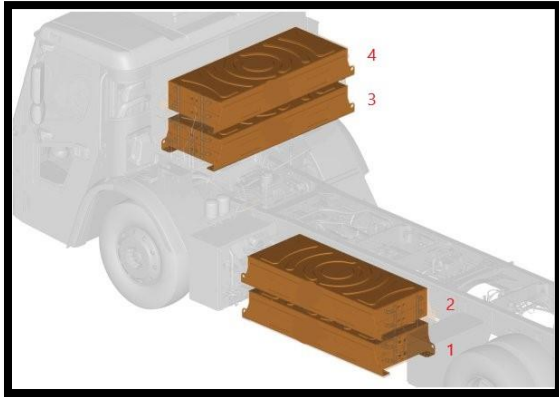

Battery 1 (A)	Bottom Frame
Battery 2 (B)	Top Frame
Battery 3 (C)	Bottom Back of Cab
Battery 4 (D)	Top Back of Cab

	Removed ESS Serial Number	Replacement ESS Serial Number
ESS #1		
ESS #2		
ESS #3		
ESS #4		