

June 16, 2023

Version 1

## Safety Recall: 2018–23 Odyssey Install FAKRA Service Cables at MOST Bus Network

### AFFECTED VEHICLES

Year	Model	Trim Level	VIN Range
2018–2023	Odyssey	ALL except LX	Check iN for VIN Eligibility

### BACKGROUND

A coaxial cable terminal was not manufactured to proper specifications. An improperly manufactured terminal may lead to poor communication in the MOST bus network which can potentially affect the quality of audio sound and/or potentially cause the rearview camera to work intermittently or go blank when the vehicle is in the reverse gear.

### CUSTOMER NOTIFICATION

Owners of affected vehicles will be sent a notification of this safety recall.

Do an iN VIN status inquiry to verify eligibility.

Some vehicles affected by this campaign may be in your new or used vehicle inventory.

Failure to repair a vehicle subject to a recall or campaign may subject your dealership to claims or lawsuits from the customer or anyone else harmed as a result of such. To see if a vehicle in inventory is affected by this safety recall, do a VIN status inquiry before selling it.

**NOTE: ALL VEHICLES AFFECTED** on this action must be repaired independent if the vehicle was repaired previously using the following Service Bulletins:

- *20-049, 2021 Odyssey: Popping or Crackling from the Speakers; No Sound from the Audio System; Network Loss Message and/or Display Issues*
- *21-013, Warranty Extension: 2018–20 Odyssey MOST Bus Network Connectors*

### CORRECTIVE ACTION

Install the FAKRA splice repair service cables, and splice boxes.

**CUSTOMER INFORMATION:** The information in this bulletin is intended for use only by skilled technicians who have the proper tools, equipment, and training to correctly and safely maintain your vehicle. These procedures should not be attempted by “do-it-yourselfers,” and you should not assume this bulletin applies to your vehicle, or that your vehicle has the condition described. To determine whether this information applies, contact an authorized Honda automobile dealer.

## PARTS INFORMATION

Part Name	Part Number	Quantity
Splice Box	39817-THR-305	7 Splice boxes (14 halves)
FAKRA Splice repair service cable (Green)	39165-THR-AB0	3
FAKRA Splice repair service cable (Red)	39165-THR-AA0	3
FAKRA Splice repair service cable (Blue)	39165-THR-AC0	1

## TOOL INFORMATION

Tool Name	Tool Number	Quantity
Straight FAKRA Puller	07AAC-THRA200	1
Cargo Cap Screw Socket	07AAA-SEPA100	1
Digital Borescope	BK5600DUAL55	1

## WARRANTY CLAIM INFORMATION

Operation Number	Description	Flat Rate Time	Defect Code	Symptom Code	Template ID	Failed Part Number
0101T3	<b>2018–2023 Odyssey:</b> Access the gauge control module, Infotainment Control Unit, in-line connector, and stereo amplifier or tuner- amplifier unit, then replace the affected FAKRA connectors with FAKRA splice repair service cables, and splice boxes.	1.4 hr	6MX00	EEL00	A23046A	39540-THR-A87

Skill Level: Repair Technician

## FAKRA CONNECTOR HOUSING DISASSEMBLY/FAKRA SPLICE REPAIR SERVICE CABLE ASSEMBLY PROCEDURE

1. Follow the below procedure to gain access to the appropriate listed vehicle components to apply the FALKRA splice repair service cables and splice boxes.
2. The connectors will either be the original FAKRA housing or the WPC FAKRA service housing.

### NOTE:

- There may be multiple components that require the affected FAKRA connectors to be removed.
- Use either the straight FAKRA puller or the 90° FAKRA A/B Puller to remove the connector from a component.

### Original Farka Housing Removal Procedure

1. Use a small screwdriver, remove the secondary lock, then release the tab as shown.

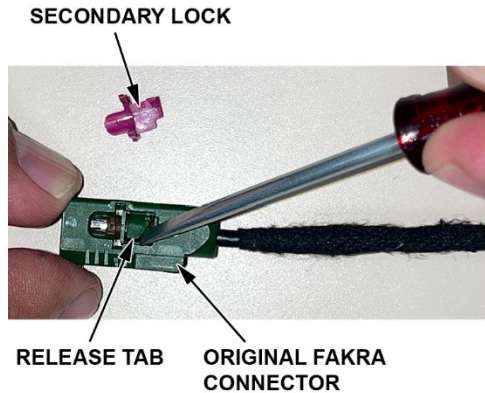

2. Pull to remove the housing form the vehicle harness. Then, **discard** the housing and lock.

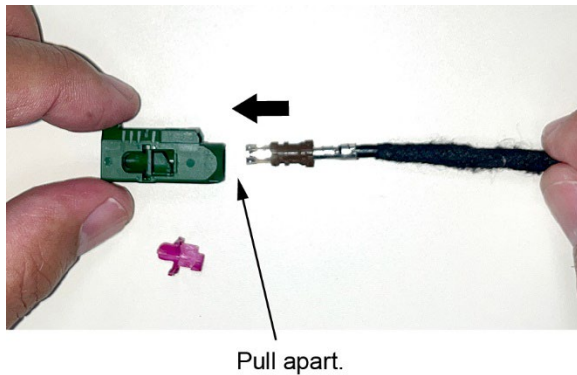

### WPC FAKRA Service Housing Removal Procedure

1. Release the two locking tabs on the WPC FAKRA Service Housing and remove the housing from the terminal.

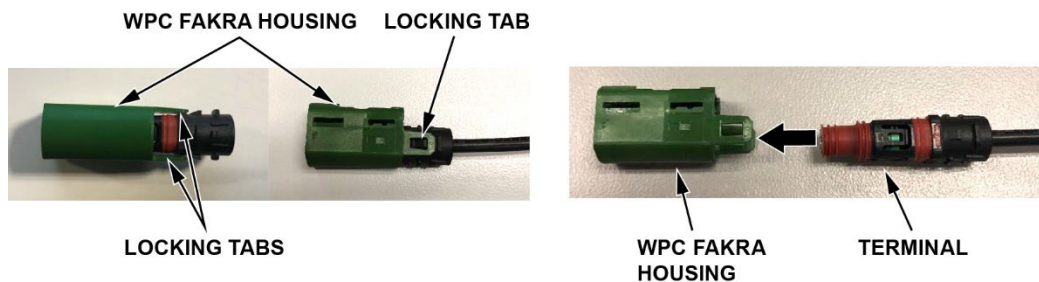

2. Release the lock tab and remove the terminal from the vehicle harness.



TERMINAL RELEASE TAB

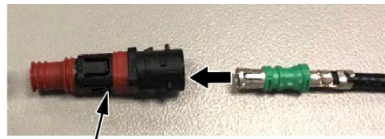

TERMINAL

### FAKRA Splice Repair Service Cable Assembly

1. Install the appropriate FAKRA splice repair service cables and splice boxes as shown in the steps that follow:

NOTE:

- The splice box arrow must always point in the direction of either the red flag label or red sleeve on the FAKRA splice repair service cable.
- If the splice box is installed **incorrectly**, the repair will fail; MOST ring failure conditions will still occur.

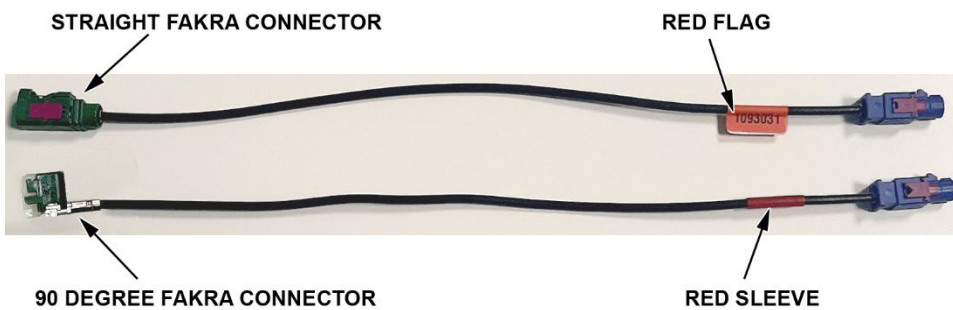

2. Use a small screwdriver to remove the secondary lock and then, release the tab.

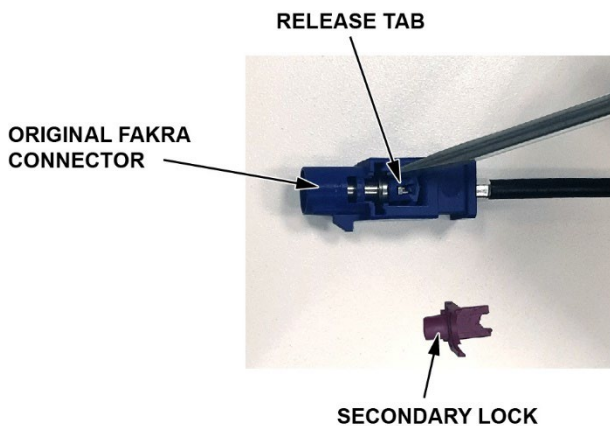

3. Pull to remove the housing from the cable and then discard the housing and secondary lock tab from the FAKRA splice repair service cable.

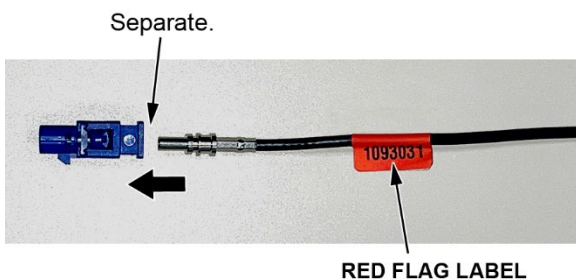

4. Connect the appropriate color FAKRA splice repair service cable to the vehicle harness.

NOTE: Always disassemble the connectors one at a time to avoid swapping the green and red wires.

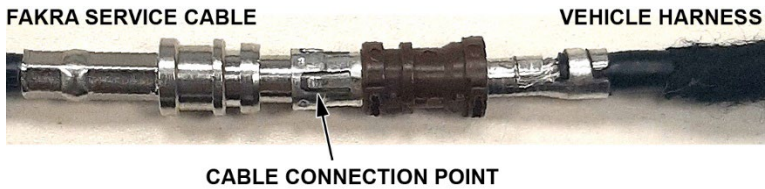

5. Attach the splice box halves to the cable connection as shown.

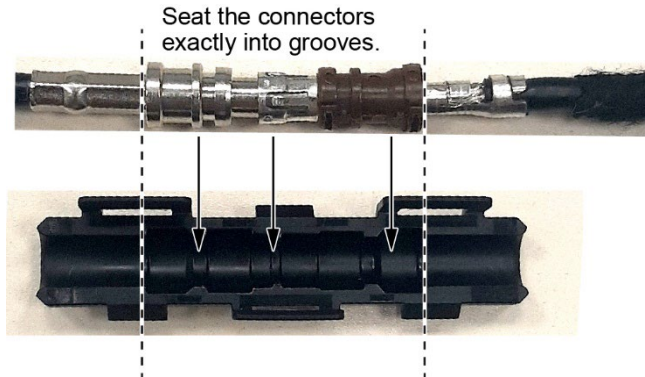

6. When mating the two splice box halves, **make sure** that all **6 lock tabs** are fully engaged. You may hear a click when installing the two halves.

NOTE:

- The splice box arrow must always point in the direction of the red flag label or red sleeve on the FAKRA splice repair service cable.
- If any of the lock tabs break during installation, the splice box half(s) must be replaced.
- If the splice box is installed **incorrectly**, the repair will fail; MOST ring failure conditions will still occur.

**CORRECT** ✓

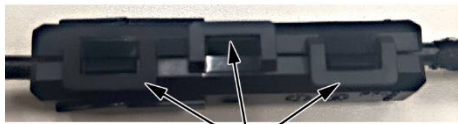

**INCORRECT** ✗

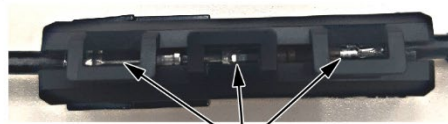

7. Make sure the arrow on the splice box **faces** towards the tag.

**CORRECT** ✓



**INCORRECT** ✗





8. Once the FAKRA splice repair service cables and splice boxes have been attached to the cable connection, tape the splice boxes and FAKRA service cables to the appropriate component harness.



Keep smooth curves with a radius bend greater than 25 mm.

**CORRECT** ✓



Keep smooth curves with a radius bend greater than 25 mm.



**INCORRECT** ✗

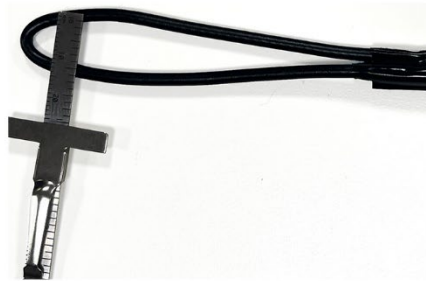

## REPAIR PROCEDURE

### Odyssey – TRIM REMOVAL PROCEDURE

1. Remove side cover.



DASHBOARD  
SIDE COVER

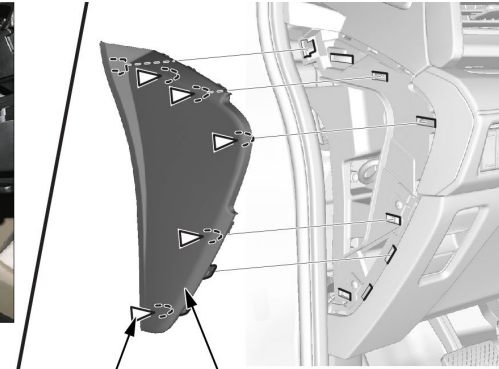

CLIPS (5)  
DASHBOARD  
SIDE COVER

2. Remove the two screws.



SCREWS

3. Remove the lower vent covers.



LOWER  
VENT  
COVER

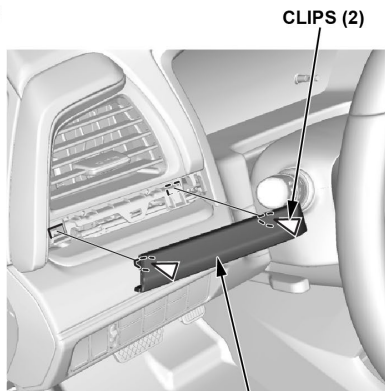

CLIPS (2)  
LOWER VENT COVER

4. Remove the lower dash panel.



LOWER DASH PANEL

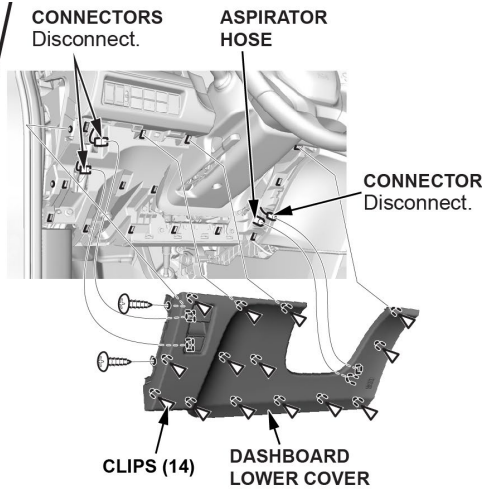

5. Loosen the upper column cover.



UPPER COLUMN COVER

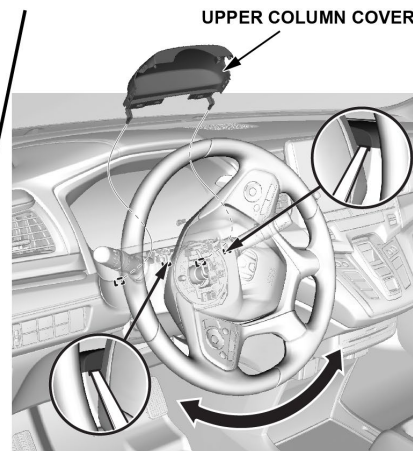

6. Disengage the clips around the meter bezel. Then remove the meter bezel and upper column cover as one piece.



DASHBOARD  
METER VISOR

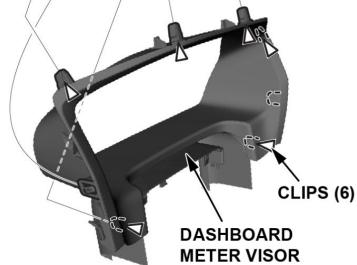
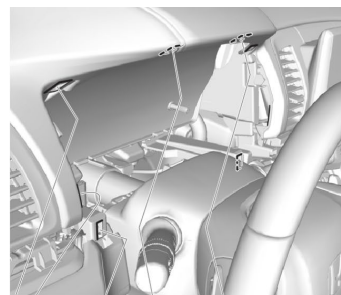



7. Remove the three screws holding the gauge control module.

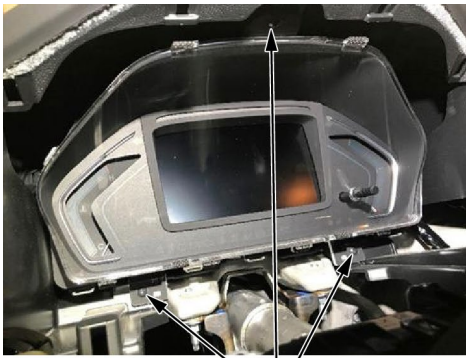

SCREWS

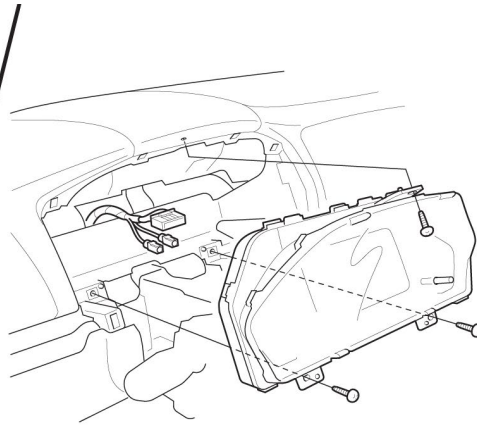

8. Remove the driver's side lower console panel.



DRIVER LOWER  
CONSOLE PANEL

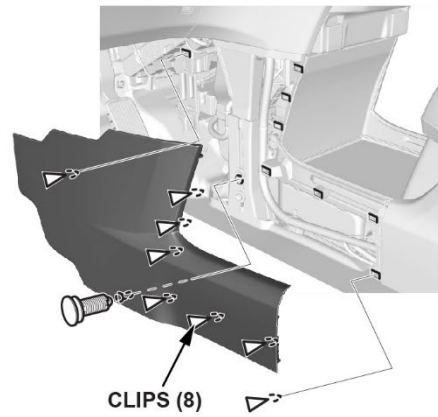

CLIPS (8)

9. Remove the driver's side kick panel.



DRIVER'S SIDE  
KICK PANEL

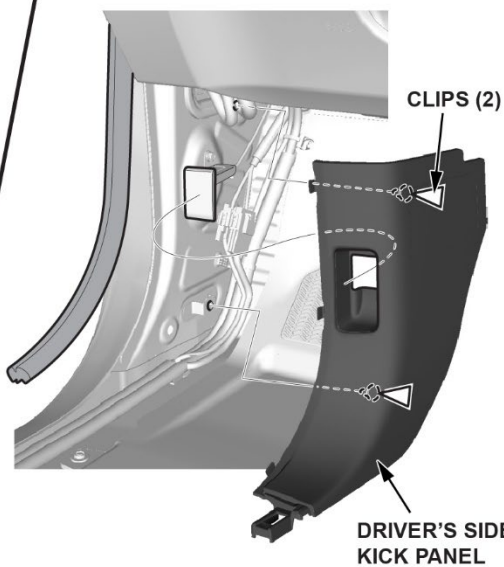

CLIPS (2)

DRIVER'S SIDE  
KICK PANEL

10. Remove the cover above the center display unit.



11. Remove the center dash trim.



12. Remove the passenger side lower panel.

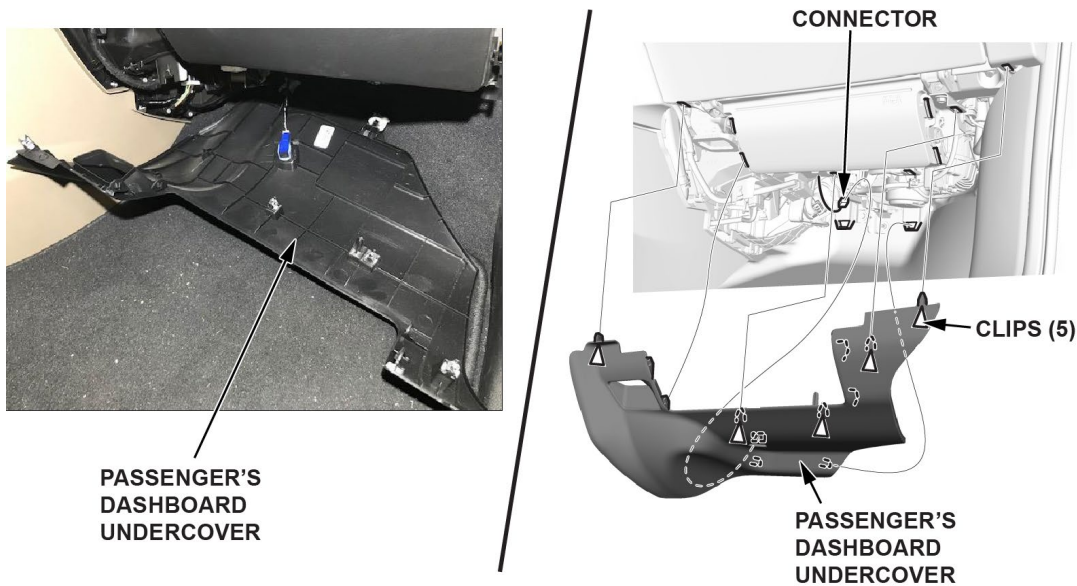

13. Remove the passenger lower console panel.

**PASSENGER'S SIDE**

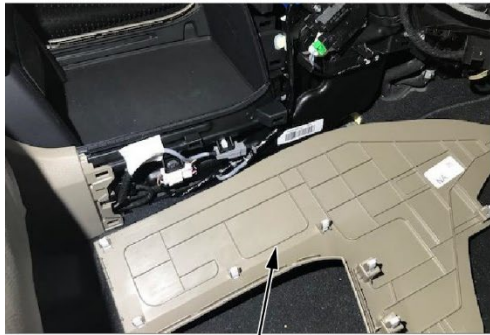

**PASSENGER LOWER  
CONSOLE PANEL**

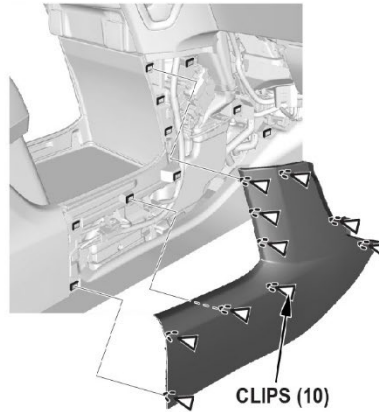

14. Remove the rubber liner and pull back the lower console cover.



**RUBBER  
LINER**

15. Remove the dashboard center lower cover and bolt as well as any connectors.

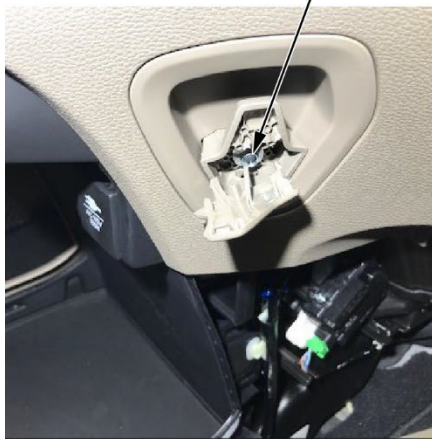

**BOLT**

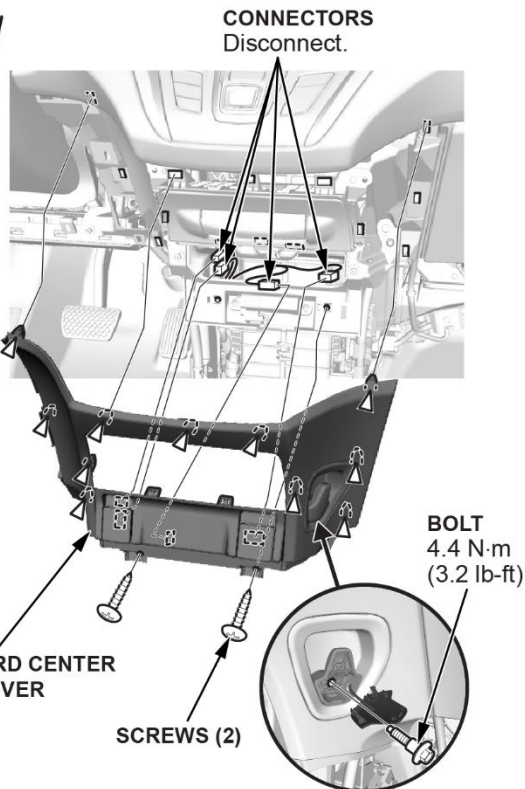

**CONNECTORS  
Disconnect.**

**BOLT  
4.4 N-m  
(3.2 lb-ft)**

**DASHBOARD CENTER  
LOWER COVER**

**SCREWS (2)**



16. On the DVD player or center pocket, remove the two upper bolts; loosen the two lower bolts.

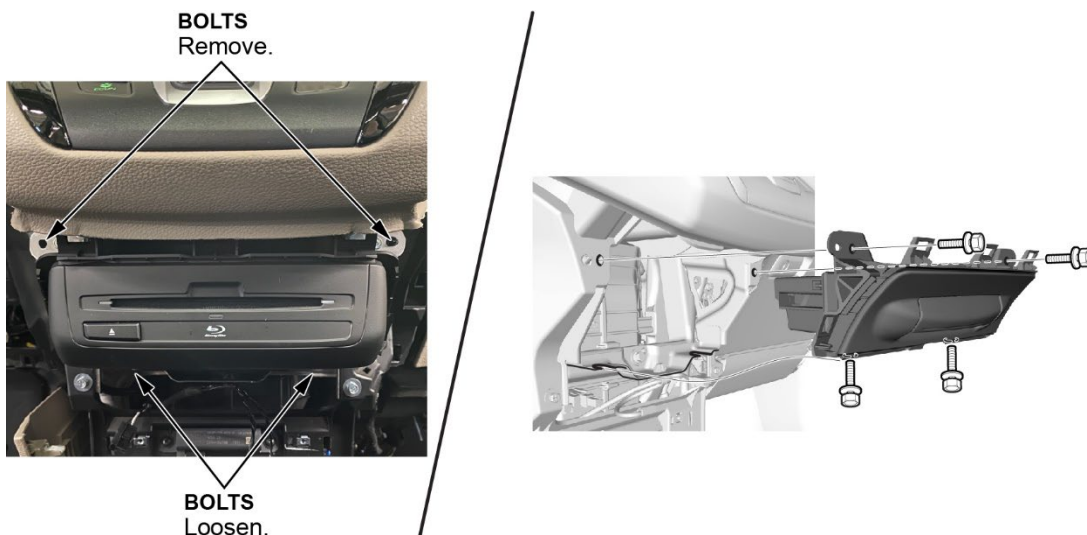

17. Remove the DVD player or center pocket to gain access to the two 8 mm bolts holding the Infotainment Control Unit.



18. Remove the screws.

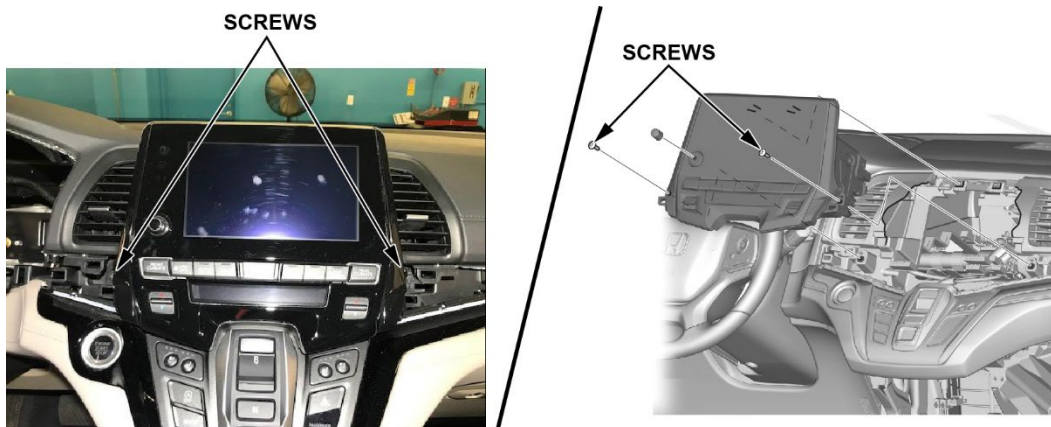



19. Remove the two screws from the dashboard center pocket, then pull back the panel.



**SCREWS**



**DASHBOARD CENTER POCKET**

20. While looking upward from underneath (where the DVD player, CD player, or center pocket was located) loosen the two 8 mm bolts holding the infotainment unit, then remove the unit.



**BOLTS**

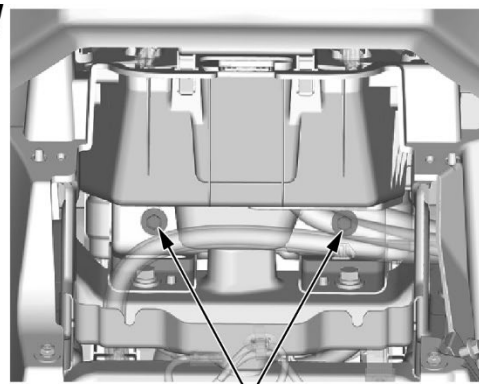

**BOLTS**  
4.4 N·m  
(3.2 lb-ft)

21. In the rear cargo area, remove the rear trim panel. On the right rear quarter panel, remove the hook bolts. If needed, use Cargo Cap Screw Socket (T/N 07AAA-SEPA100) to loosen the bolts.

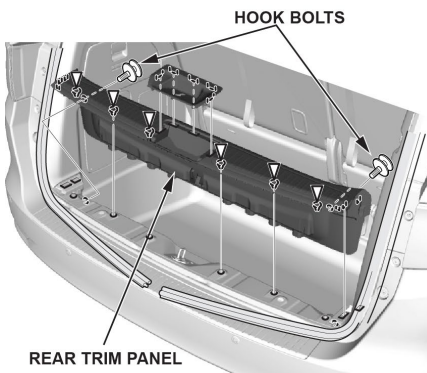

**HOOK BOLTS**

**REAR TRIM PANEL**

If necessary, use Special Tool 07AAA-SEPA100 to loosen the hook bolts.

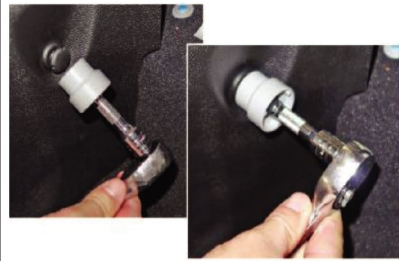

22. Remove the lower passenger sliding door trim.



LOWER PASSENGER  
SLIDING DOOR TRIM

23. Remove the covers then remove the two screws from the passenger side inner rear quarter panel.

NOTE:

- Only the driver side rear quarter panel from the service manual is **shown below**.
- All callouts on the service manual image **apply** to the passenger side rear quarter panel.



SCREWS  
PASSENGER SIDE  
INNER REAR  
QUARTER PANEL

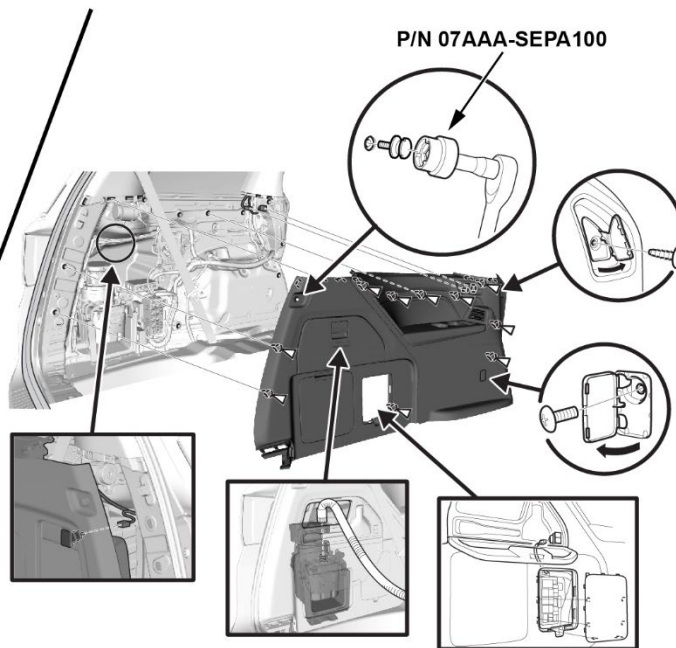

24. Remove the right quarter inner panel and the connectors.

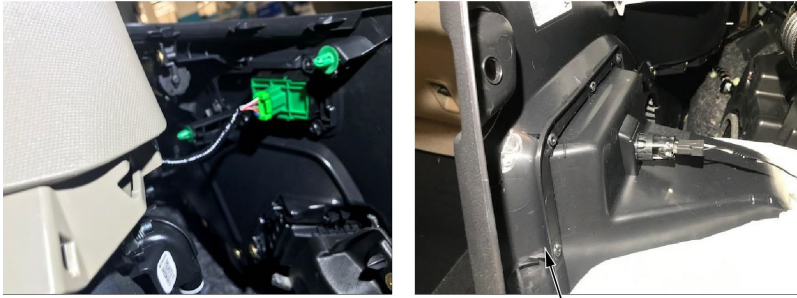

RIGHT QUARTER INNER PANEL

25. Follow the steps below to install the FAKRA splice repair service cables and splice boxes at **each** component location.

**NOTE:** See the **FAKRA CONNECTOR HOUSING DISASSEMBLY/FAKRA SPLICE REPAIR SERVICE CABLE ASSEMBLY PROCEDURE SECTION** above for cable and splice box installation instructions.

## ODYSSEY – GAUGE CONTROL MODULE REPAIR PROCEDURE

1. Turn the gauge control module to access the rear connectors.

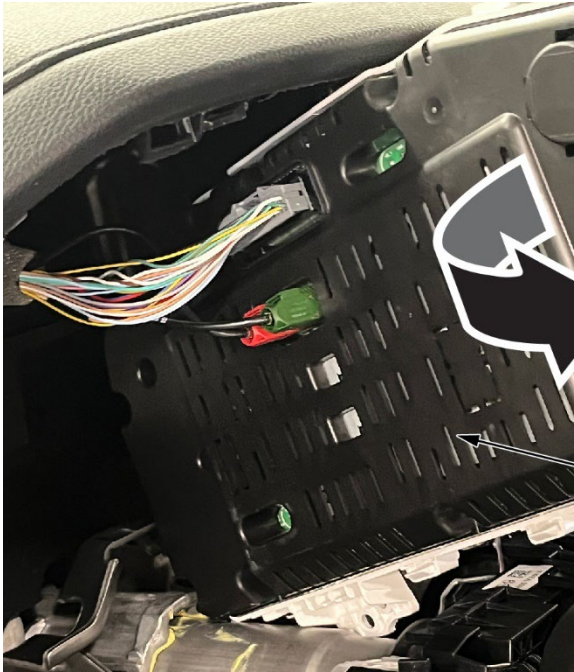

**MODULE**  
Turn over.

2. Disconnect the FAKRA connectors and any other related connectors at the gauge control module.

**NOTE:** Disassemble the connectors one at a time to avoid swapping the green and red wires.

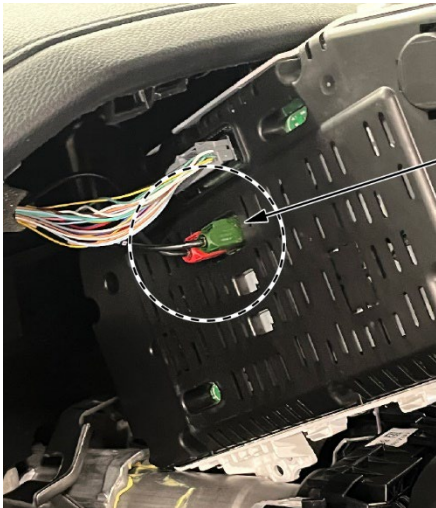

**FAKRA CONNECTORS**  
Disconnect.



3. Install the matching color FAKRA splice repair service cables and splice boxes.

NOTE:

- See the above section **FAKRA CONNECTOR HOUSING DISASSEMBLY/FAKRA SPLICE REPAIR SERVICE CABLE ASSEMBLY PROCEDURE SECTION** for detailed instructions.
- **The splice box arrow must always point in the direction of the red flag label or red sleeve on the FAKRA splice repair service cable.**
- If any of the lock tabs break during installation, the splice box halve(s) must be replaced.
- If the splice box is installed **incorrectly**, the repair **will fail**; MOST Ring failure conditions will still occur.

4. Tape both splice boxes and cables to the gauge control module harness.

Attach fakra service cables and splice boxes to the appropriate component harness with tape to prevent any rattles.



Keep smooth curves with a radius bend greater than 25 mm.

5. Reconnect the FAKRA connectors and any other related connectors to the gauge control module.
6. Position the gauge control module into its position but **do not** install the mounting screws yet.

7. Using the digital borescope (T/N BK5600DUAL55) or a commercially available borescope with multiple view angles, inspect the cable routing at the back of the gauge control module as shown below to make sure the cables are routed straight and not sideloaded. Adjust gauge control module harness as needed to achieve proper cable routing.



**CORRECT** ✓

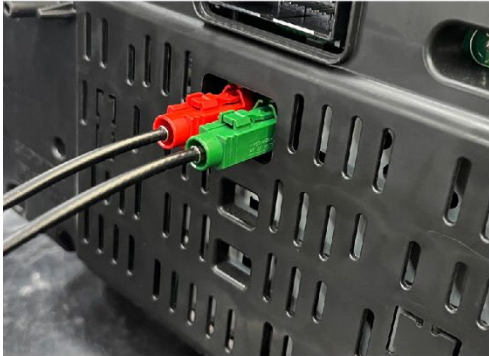

**INCORRECT** ✗

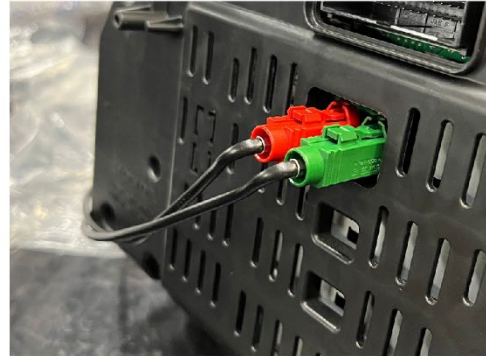

8. Once you have confirmed the cable routing is correct, install the control module mounting screws.

## ODYSSEY – INFOTAINMENT CONTROL UNIT REPAIR PROCEDURE

1. Disconnect the red and green FAKRA connectors and any other related connectors at the Infotainment Control Unit.

NOTE: Disassemble the connectors one at a time to avoid swapping the green and red wires.

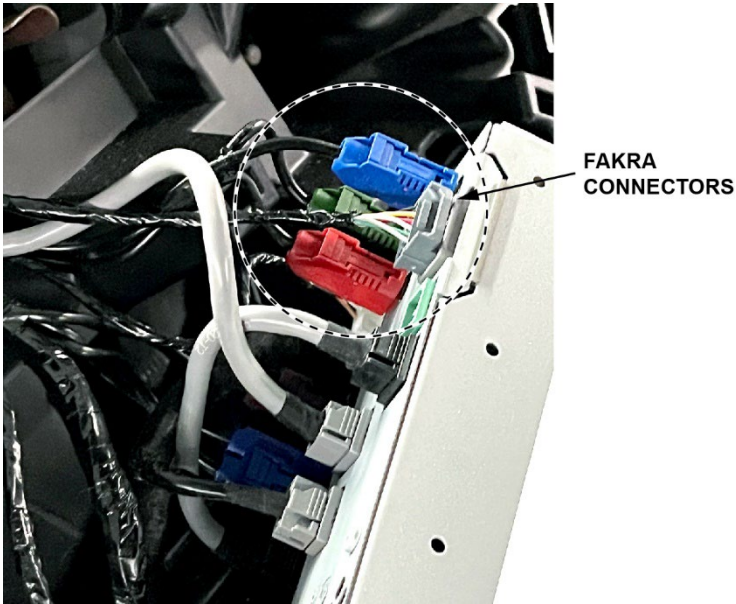

2. Install the matching color FAKRA splice repair service cables and splice boxes.

NOTE:

- See the above section **FAKRA CONNECTOR HOUSING DISASSEMBLY/FAKRA SPLICE REPAIR SERVICE CABLE ASSEMBLY PROCEDURE SECTION** for detailed instructions.
- **The splice box arrow must always point in the direction of the red flag label or red sleeve on the FAKRA splice repair service cable.**
- If any of the lock tabs break during installation, the splice box halve(s) must be replaced.
- If the splice box is installed **incorrectly**, the repair **will fail**; MOST Ring failure conditions will still occur.

3. Tape both splice boxes and cables to the Infotainment Control Unit Harness.

Keep smooth curves with radius bend greater than 25 mm.



Attach the fakra service cables and splice boxes to the appropriate component harness with tape to prevent any rattles.

4. Reconnect the FAKRA connectors and any other related connectors to the Infotainment unit.
5. Position the Infotainment Control Unit into its mounting position.



6. Using the digital borescope (T/N BK5600DUAL55) or a commercially available borescope with multiple view angles, inspect the cable routing at the back of the gauge control module as shown below to make sure the cables are routed straight and not sideloaded. Adjust gauge control module harness as needed to achieve proper cable routing.



**CORRECT** ✓

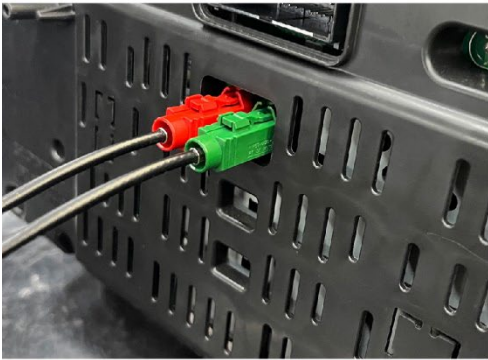

**INCORRECT** ✗

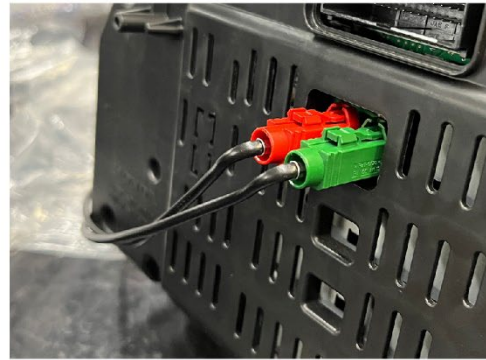

7. Once you have confirmed the cables routing is correct, install the Infotainment Control Unit mounting screws.

## ODYSSEY – IN-LINE CONNECTOR REPAIR PROCEDURE

1. Disconnect the blue FAKRA connector at the driver's kick panel.



FAKRA  
CONNECTOR

2. Install the matching color FAKRA splice repair service cable and splice box.

### NOTE:

- See the above section **FAKRA CONNECTOR HOUSING DISASSEMBLY/FAKRA SPLICE REPAIR SERVICE CABLE ASSEMBLY PROCEDURE SECTION** for detailed instructions.
  - **The splice box arrow must always point in the direction of the red flag label or red sleeve on the FAKRA splice repair service cable.**
  - If any of the lock tabs break during installation, the splice box halve(s) must be replaced.
  - If the splice box is installed **incorrectly**, the repair **will fail**; MOST Ring failure conditions will still occur.
3. Tape both the splice box and cable to the in-line unit harness.
  4. Reconnect the blue in-line FAKRA connector.

## ODYSSEY – AMPLIFIER/TUNER-AMPLIFIER REPAIR PROCEDURE

1. Disconnect the red and green FAKRA connectors at the amplifier.



2. Install the matching color FAKRA splice repair service cables and splice boxes.

### NOTE:

- See the above section **FAKRA CONNECTOR HOUSING DISASSEMBLY/FAKRA SPLICE REPAIR SERVICE CABLE ASSEMBLY PROCEDURE SECTION** for detailed instructions.
- **The splice box arrow must always point in the direction of the red flag label or red sleeve on the FAKRA splice repair service cable.**
- If any of the lock tabs break during installation, the splice box halve(s) must be replaced.
- If the splice box is installed **incorrectly**, the repair **will fail**; MOST Ring failure conditions will still occur.

3. Tape both splice boxes and cables to the amplifier, or tuner-amplifier harness.

Attach the fakra service cables and splice boxes to the appropriate component harness with tape to prevent any rattles.

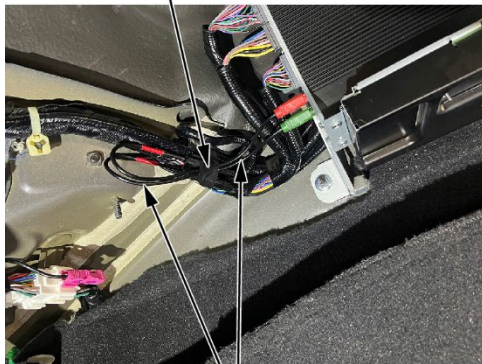

4. Reconnect the FAKRA connectors and any other related connectors to the amplifier (Elite) or tuner-amplifier (EX, EX-L, Touring).

## ODYSSEY – REPAIR VERIFICATION PROCEDURE

1. Install all of the removed parts in the reverse order of removal.

### NOTE:

- When reinstalling vehicle components, make sure the harness is routed correctly. A **misrouted harness** can put pressure on the wires and connectors, causing connection issues.
  - **Do not pull** on the components or MOST cables while the FAKRA connectors are connected to help prevent communication issues.
2. Start the vehicle and verify the gauge control module, Infotainment Control Unit operates normal, push the power button OFF, open and close the driver's door and restart the vehicle. Reverify the gauge control module, Infotainment Control Unit operates normal. If all systems operate normal, repair is complete.
  3. If the gauge control module or infotainment unit do not operate as intended after application, reinspect the FAKRA splice repair service cables, splice box connections, and routing. Make sure the splice box arrow is pointing to the red flag label or red sleeve on the FAKRA Splice box service cable.

NOTE: If all FAKRA Splice repair service cables, splice box connections and routing are correct follow normal troubleshooting procedures per System Information Search on iN.

END