



SIB 52 13 23

2023-07-05

RECALL 23V-414: FRONT SEAT RAILS

This Service Information Bulletin (Revision 1) replaces SI B52 13 23 **dated June 2023**.

What's New:

- Recall number 23V-414 added to SIB title
- Cause, correction, procedure, claim, and parts information added
- Attachments updated with Recall number

<input checked="" type="checkbox"/>	THIS REPAIR IS MOBILE FRIENDLY
-------------------------------------	--------------------------------

MODEL

E-Series	Model Description	Production Date
G70	7 Series Sedan	November 30, 2022 – January 18, 2023

AFFECTED VEHICLES

Vehicles which require this campaign to be completed will show it as “Open” when checked either in AIR, AWP, Campaign Summary or Warranty Vehicle Inquiry.

Please make sure you check your dealer inventory as soon as possible. As of June 3, 2023, you can see a list of affected vehicles in Inventory Campaign Details (ICD) under ROSS.

SITUATION

BMW AG is conducting a Voluntary Safety Recall (effective June 2, 2023) on certain Model Year 2023 BMW 7 Series vehicles that were produced between November 30, 2022, and January 18, 2023.

The front seat rail (driver and/or passenger) may not have been produced according to specifications by the supplier. This could affect the structural integrity of the seat frame and, in certain crashes, could increase the risk of injury.

The Recall Notice and Q&A have been attached for further information.

CAUSE

One batch of seat frames may have insufficient welding on the right-side seat rail. The weld could break and impair the restraint function of the seat in the event of a crash/accident. This could occur at the rear of the right-side seat rail as shown below.

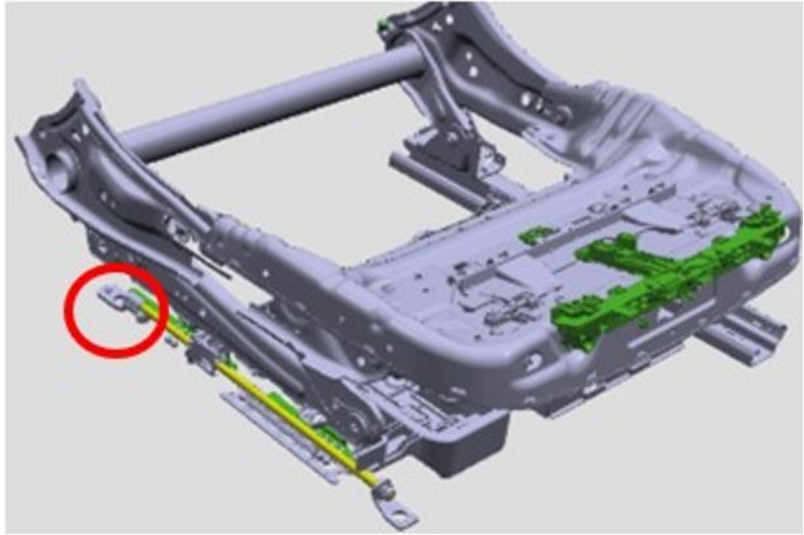

CORRECTION

Check the seat length adjustment of both front seats' right rails and replace damaged seat rails if found.

We anticipate a small number of seat frames to be affected and all frames manufactured within batch number **00017**.

PROCEDURE

Check the seat length adjustment on both front seats.



Inspect the right rear of both front seat rails for insufficient welding.

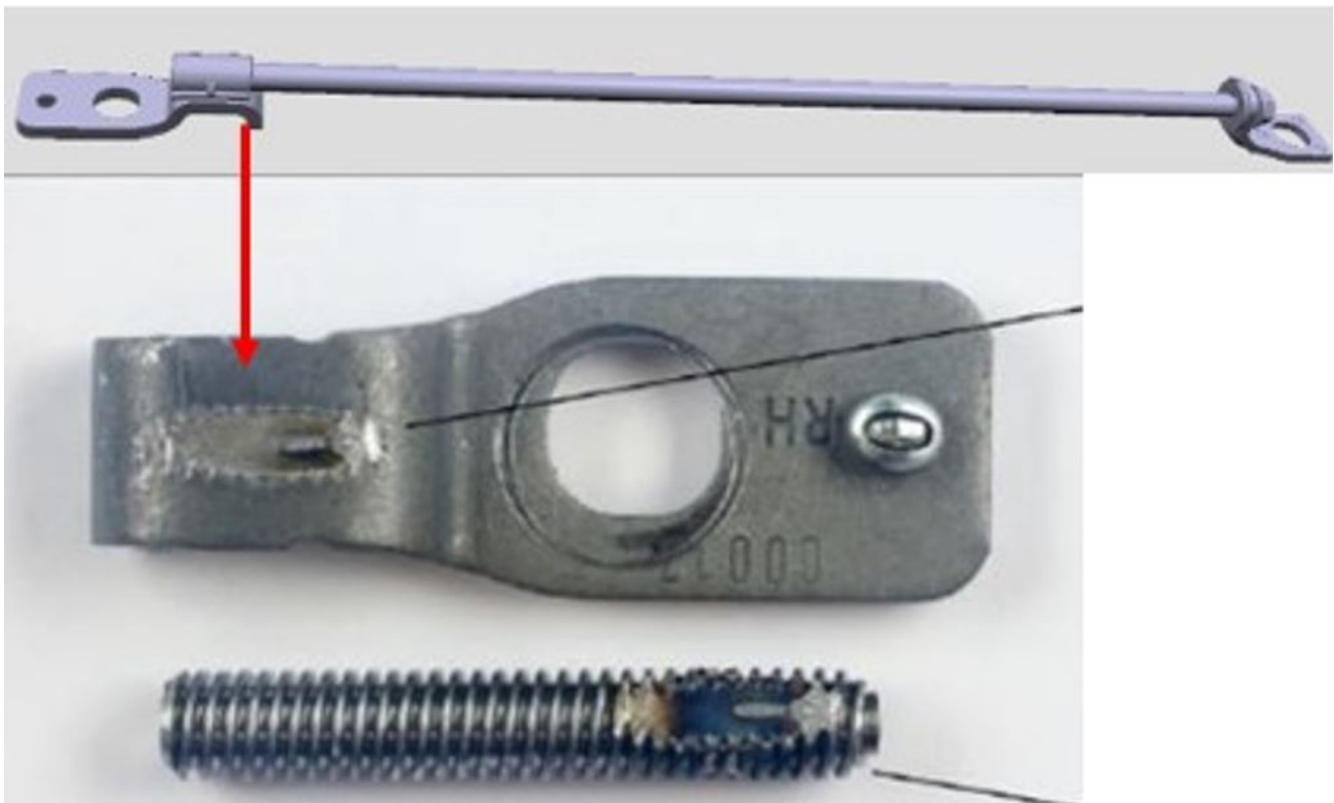

Inspect the seat rail closely and read the batch number. If the mounting bolt is in the way of reading the batch number, it can be removed but must be replaced even if the seat rail is not being replaced.

If the batch number is **00017** then replace the seat rail and all seat mounting bolts. All other batch numbers should be inspected but should not need to be replaced.



PARTS INFORMATION

When applicable, only use and invoice the part numbers listed below that apply.

Please only order parts if damage was detected during the inspection, as the expected exchange rate is
Copyright ©2023 BMW of North America, Inc.

Part Number	Description	Quantity
52 10 5 A47 D15	Seat length adjustment (left seat)	1 if required
52 10 5 A47 D16	Seat length adjustment (right seat)	1 if required
52 10 5 A47 D38	Mounting kit length adjustment	1 if required
07 14 9 321 690	Cylinder screw	1-8 max all If required
72 11 5 A5A 464	Torx screw	1-2 If required

CLAIM INFORMATION

Reimbursement for this Recall will be via normal claim entry utilizing the applicable work package information below and when required, the part numbers above that apply.

Repair Code:	0052130200	---
---------------------	-------------------	-----

Completion before the first vehicle delivery to a customer or the vehicle is already in the workshop

Work Pkg	Labor Operation	Description (Plus work)	Labor Allowance
# 1	00 74 804	Check the right seat length adjustment on both front seats (No repair is necessary)	3 FRU
Or:			
# 2	00 74 805	Check the right seat length adjustment on both front seats, replace one seat length unit	17 FRU
Or:			
# 3	00 74 806	Check the right seat length adjustment on both front seats; replace both seat length units	32 FRU

Or:

The vehicle arrives at your center and this Recall shows open (No other Main work will be performed or claimed during this workshop visit)

Work Pkg	Labor Operation	Description (Main work)	Labor Allowance
# 4	00 74 172	Check the right seat length adjustment on both front seats (No repair is necessary)	5 FRU
Or:			
# 5	00 74 173	Check the right seat length adjustment on both front seats, replace one seat length unit	19 FRU
Or:			
# 6	00 74 174	Check the right seat length adjustment on both front seats; replace both seat length units	33 FRU; 34 FRU (i7 xDrive60)

Only one of the flat rate labor operation codes listed above can be used for claim submission and reimbursement. Also, only one Main work flat rate labor operation code can be claimed per workshop visit.

Claim Repair Comments

Only reference the SIB number and the work package (Pkg) number performed in the RO technician notes and the claim comments (For example: B52 13 23 WP 1), unless otherwise required by State law.

Alternative Mobility Solution (AMS) for Vehicle Owners (RO and Claim Comments Required)

Copyright ©2023 BMW of North America, Inc.

This Recall repair qualifies for Alternative Mobility Solution (AMS) expense reimbursement, claim this item under the Defect Code noted above as follows:

- Sublet Code 2 - Itemize the AMS sublet amount on the repair order and in the claim comment section.

Please refer to [SI B01 29 16](#) for additional information.

Reimbursement of Prior Customer-Pay Repairs (TREAD Act)

Based on the issue and the age of the Affected Vehicles being addressed by this Safety Recall Campaign, a reimbursement request for a qualifying prior customer-pay repair is not likely.

However, if you do receive a reimbursement request from a customer for a prior repair that may qualify, please contact the Warranty department (include a legible copy of the invoice) through IDS by selecting Coverage, Policy, Coding Questions and Mileage Corrections. The Warranty department will review and respond to your inquiry accordingly.

FEEDBACK REGARDING THIS BULLETIN

Technical Feedback	To submit feedback for the technical topic of this bulletin: Submit your feedback in the rating box at the top of this bulletin
Warranty Feedback	To submit feedback for the CLAIMS section of this bulletin: Submit an IDS ticket to the Warranty Department, or use the chat available in the Warranty Documentation Portal
Parts Feedback	To submit feedback for the PARTS section of this bulletin: Submit an IDS ticket to the Parts Department

Supporting Materials

[picture_as_pdf 23V-414-G70-FrontSeat-FAQ-\(02Jun2023\).pdf](#)
[picture_as_pdf B521323 Recall Notice.pdf](#)

SAFETY RECALL NOTICE

To: All Center Operators, Sales Managers, Service Managers, Parts Managers and Warranty Processors

RE: Recall 23V-414: Front Seat Rails – B52 13 23

BMW AG is conducting a Voluntary Safety Recall (effective June 2, 2023) on certain Model Year 2023 BMW vehicles that were produced between November 30, 2022, and January 18, 2023.

Please be reminded that it is a violation of federal law (The Safety Act) for you to sell, lease or deliver any new motor vehicle covered by this notification until the recall repair has been performed. This means that Centers may not legally deliver new motor vehicles to consumers until they are fixed or use/sell replacement equipment/parts subject to this recall. Note also that substantial civil penalties apply to violations of the Safety Act.

Also, you should not sell, lease or deliver any Certified Pre-Owned or used vehicles subject to a safety recall until the repair is completed.

Please follow any special instructions that we provide to you for the return or disposition of recall parts.

We appreciate all your assistance with this Recall.

**Safety Recall
23V-414
Front Seat
Model Year 2023
BMW 7 Series
Issue Date: 06/02/2023**

- Q1. Which BMW Group models in the US are potentially affected by this Safety Recall?**
Certain Model Year 2023 BMW 7 Series in the US are potentially affected.
- Q2. What is the specific issue?**
The front seat (driver and/or passenger) may not have been produced according to specifications by the supplier. This could affect the structural integrity of the seat frame and, in certain crashes, could increase the risk of injury.
- Q3. Why are other models / vehicles not included in this Safety Recall?**
Other models have front seat frames produced to specifications by the supplier.
- Q4. Can I continue to drive my vehicle?**
Yes. However, when you are notified by BMW of this Safety Recall, please contact an authorized BMW center to schedule an appointment as soon as possible. For the latest updates to this Safety Recall, please visit bmwusa.com/recall. **If you are not the only driver of this vehicle, please advise all other drivers of this important information.**
- Q5. How did BMW Group become aware of the issue?**
BMW Group became aware of the issue through its quality control procedures.
- Q6. How will I be informed of this Safety Recall?**
Owners of potentially affected vehicles will be notified via First Class mail and requested to schedule an appointment with an authorized BMW center to have the remedy performed.
- To ensure BMW has the most up-to-date contact and vehicle information, owners should register their vehicle at www.bmwusa.com/myBMW. Registration is free and will give them access to other information specific for their BMW vehicle. Alternatively, owners can visit bmwusa.com/recall and click on “**Manage recall notices and contact information**”.
- Q7. How will my vehicle be remedied?**
Potentially affected vehicles will have the driver and/or front passenger seat frame inspected and, if necessary, replaced for free which should take several hours.
- Q8. Do I have to wait for BMW to contact me to have the remedy performed?**
Yes. We are in the process of implementing this Safety Recall campaign to ensure that the necessary parts are at the BMW centers. For the latest updates to this Safety Recall, please visit bmwusa.com/recall.