



Remedy available for
 2021 - 2023 (WL) Jeep Grand Cherokee L
 2022 - 2023 (WL) Jeep Grand Cherokee

Template Version 1.0

Revision	Edition	Detail
0	May 2023	Initial Version.

SYMPTOM DESCRIPTION

About 89,370 of the above vehicles may have been built with an incorrectly assembled steering column intermediate shaft which may potentially disconnect from the U-joint. Driver may notice play in steering and/or noise when turning prior to the intermediate shaft disconnecting. A disconnected intermediate shaft may result in a loss of steering control which can cause a vehicle crash without prior warning.

SCOPE

NOTE: Some vehicles above may have been identified as not involved in this recall and therefore have been excluded from this recall.

IMPORTANT: Some of the involved vehicles may be in dealer new vehicle inventory. Federal law requires you to complete this recall service on these vehicles before retail delivery. Dealers should also consider this requirement to apply to used vehicle inventory and should perform this recall on vehicles in for service. Involved vehicles can be determined by using the VIP inquiry process.

REPAIR TO BE PERFORMED

Inspect and, if necessary, replace the intermediate shaft and assembly parts.

ALTERNATE TRANSPORTATION

Dealers should attempt to minimize customer inconvenience by placing the owner in a loaner vehicle if inspection determines that repair is required, and the vehicle must be held overnight

COMPLETION REPORTING / REIMBURSEMENT

Claims for vehicles that have been serviced must be submitted on the DealerCONNECT Claim Entry Screen located on the Service tab. Claims paid will be used by FCA to record recall service completions and provide dealer payments.

Use the following labor operation numbers and time allowances:

Labor Description	Number	Hrs
Inspect I-Shaft U-Joint (3.6L, 5.7L, and 2.0L RHD Models Only)	19-58-A1-80	0.2
Inspect I-Shaft U-Joint (2.0L PHEV and 2.0L LHD Models Only)	19-58-A1-81	0.3
Inspect and Replace U-Joint Pinch Bolt and/or Spacer Clip (3.6L LHD or 5.7L LHD Models Only)	19-58-A1-82	0.5
Inspect and Replace U-Joint Pinch Bolt and/or Spacer Clip (3.6L RHD, 2.0L LHD, 2.0 PHEV LHD and RHD Models Only)	19-58-A1-83	0.8
Inspect and Replace U-Joint Pinch Bolt and/or Spacer Clip (2.0L RHD Models Only)	19-58-A1-84	0.2

Related Operations

Labor Description	Number	Hrs
Replace U-Joint (3.6L, 5.7L, and 2.0L RHD Models Only)	19-58-A1-51	0.2
Replace U-Joint (2.0L LHD and 2.0L PHEV Models Only)	19-58-A1-52	0.2
Replace Intermediate Shaft (3.6L LHD, 5.7L LHD, 2.0L RHD Models Only)	19-58-A1-53	0.2
Replace Intermediate Shaft (3.6L RHD, 2.0L LHD, and 2.0L PHEV Models Only)	19-58-A1-54	0.9
PHEV Powerdown	19-58-A1-55	0.5

Add the cost of the replaced parts plus applicable dealer allowance to your claim.

NOTE: See the Warranty Administration Manual, Recall Claim Processing Section, for complete recall claim processing instructions.

Strictly respect STELLANTIS Group safety, cleanliness, and environmental instructions for any vehicle service. Document exclusively reserved for dealer information. Internal distribution to be ensured by dealer. Reproduction forbidden without the written agreement of STELLANTIS Group. (C) 2023 STELLANTIS Group. All Rights Reserved (tdb)

SAFETY RECALL

NORTH AMERICA

Intermediate Shaft



Reference: 58A / NHTSA 23V-352

FCA US LLC

PARTS INFORMATION

No parts are required for inspection process.

NOTE: Parts can only be ordered through campaignteam@stellantis.com. Please provide the results of the inspection by answering questions below, and provide VIN, Right or Left hand drive, and Dealer Code. The Supply Chain team will order the required part(s) and ship to your dealership.

- Bolt not flush and removed for inspection - Yes/No
- Bolt threads damaged - Yes/No
- White clip missing - Yes/No
- Shaft stop not flush to clip - Yes/No

PARTS RETURN

No parts return required for this campaign.

Render any replaced parts unusable and discard.

SPECIAL TOOLS

No special tools are required to perform the inspection procedure.

These special tools are only required for PHEV repair procedure however not for the inspection.

Number	Description
126-1587	Fluke Meter, Multi
2077100080	High Voltage Test Adapter
2035100082	Covers, HEV Battery Terminal

DEALER NOTIFICATION

To view this notification on DealerCONNECT, select "Global Recall System" on the Service tab, then click on the description of this notification.

OWNER NOTIFICATION / SERVICE SCHEDULING

All involved vehicle owners known to FCA are being notified of the service requirement by first class mail. They are requested to schedule appointments for this service with their dealers. A generic copy of the owner letter is attached.

Strictly respect STELLANTIS Group safety, cleanliness, and environmental instructions for any vehicle service.

Document exclusively reserved for dealer information. Internal distribution to be ensured by dealer.

Reproduction forbidden without the written agreement of STELLANTIS Group. (C) 2023 STELLANTIS Group. All Rights Reserved

(tdb)

SAFETY RECALL

NORTH AMERICA

Intermediate Shaft



Reference: 58A / NHTSA 23V-352

FCA US LLC

VEHICLE LISTS, GLOBAL RECALL SYSTEM, VIP AND DEALER FOLLOW UP

All involved vehicles have been entered into the DealerCONNECT Global Recall System (GRS) and Vehicle Information Plus (VIP) for dealer inquiry as needed.

GRS provides involved dealers with an updated VIN list of their incomplete vehicles. The owner's name, address and phone number are listed if known. Completed vehicles are removed from GRS within several days of repair claim submission.

To use this system, click on the "**Service**" tab and then click on "**Global Recall System**." Your dealer's VIN list for each recall displayed can be sorted by: those vehicles that were unsold at recall launch, those with a phone number, city, zip code, or VIN sequence.

Dealers must perform this repair on all unsold vehicles before retail delivery. Dealers should also use the VIN list to follow up with all owners to schedule appointments for this repair.

Recall VIN lists may contain confidential, restricted owner name and address information that was obtained from the Department of Motor Vehicles of various states. Use of this information is permitted for this recall only and is strictly prohibited from all other use.

ADDITIONAL INFORMATION

If you have any questions or need assistance in completing this action, please contact your Service and Parts District Manager.

Customer Services / Field Operations
FCA US LLC.

SERVICE PROCEDURE

NOTE: The following inspection and repair procedures may be different based on engine type and if vehicle is Right Hand Drive (RHD) or Left Hand Drive (LHD) so please follow the directions carefully.

A. Inspection Procedure

1. Position the vehicle on a suitable lift.
2. Open the engine compartment hood.
3. For vehicles equipped with the following:
 - **2.0L PHEV Engine (Sales Code ECX) with RHD or LHD steering.**
 - **2.0L Turbo Engine (Sales Code EC1) with LHD steering.**

Front wheel assembly removal will be necessary on the same side of the vehicle as the steering column in order to complete the inspection process.

NOTE: Engine and Steering combinations other than those listed above will not require this step.

- a) Raise and support the vehicle.
- b) Remove the front wheel assembly from the same side of the vehicle as the steering column.
- c) Inspection access to the steering U-joint coupling through opening as shown (Figure 1).

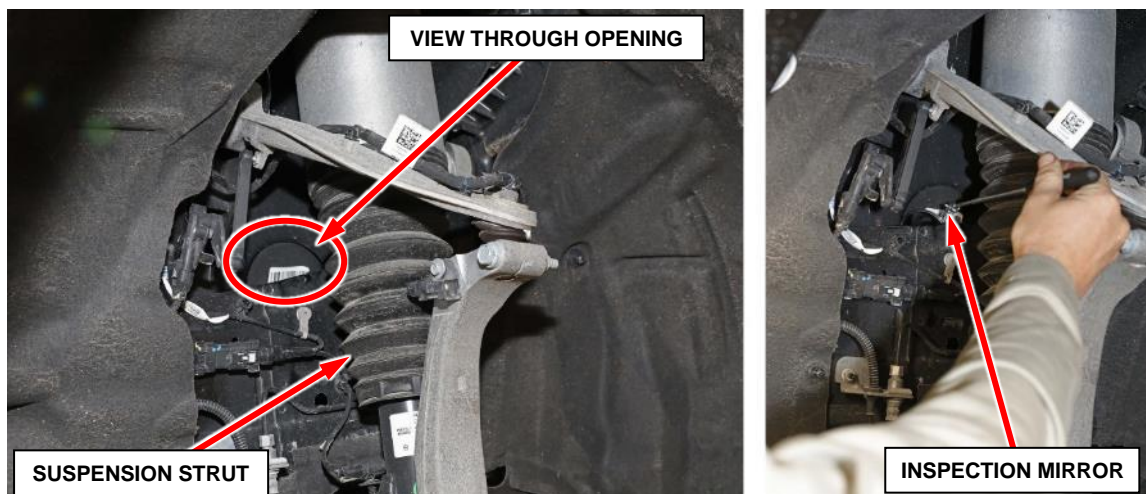

Figure 1 – Inspection Access Location

SAFETY RECALL

NORTH AMERICA

Intermediate Shaft



Reference: 58A / NHTSA 23V-352

FCA US LLC

Inspection may be performed from under hood in engine compartment for vehicles equipped with the following (Figure 2):

- 3.6L Engine (Sales Code ERC) with RHD or LHD steering.
- 5.7L Engine (Sales Code EZH) with LHD steering.
- 2.0L Turbo Engine (Sales Code EC1) with RHD steering.

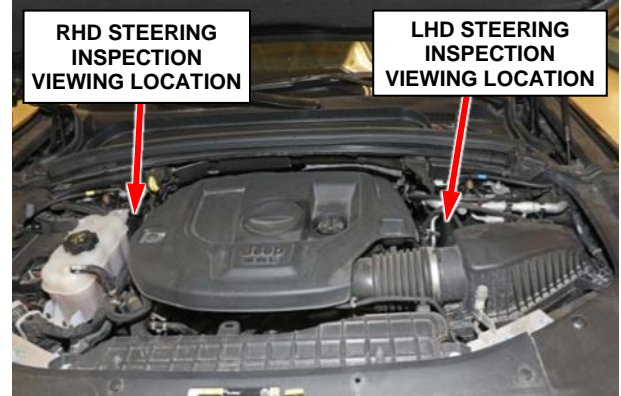

Figure 2 – Inspection Access Location

NOTE: Use a flashlight and mirror and rotate the steering column as necessary for best viewing angle during the following inspection procedure steps.

NOTE: Best viewing angle for inspection may vary depending on vehicle configuration. I-shaft U-joint should be visible from under hood in engine compartment unless previous step directed wheel removal then inspect through wheelhouse opening just in front of suspension strut.

4. Visually locate the steering column intermediate shaft to U-joint interface connection for inspection (Figure 3).

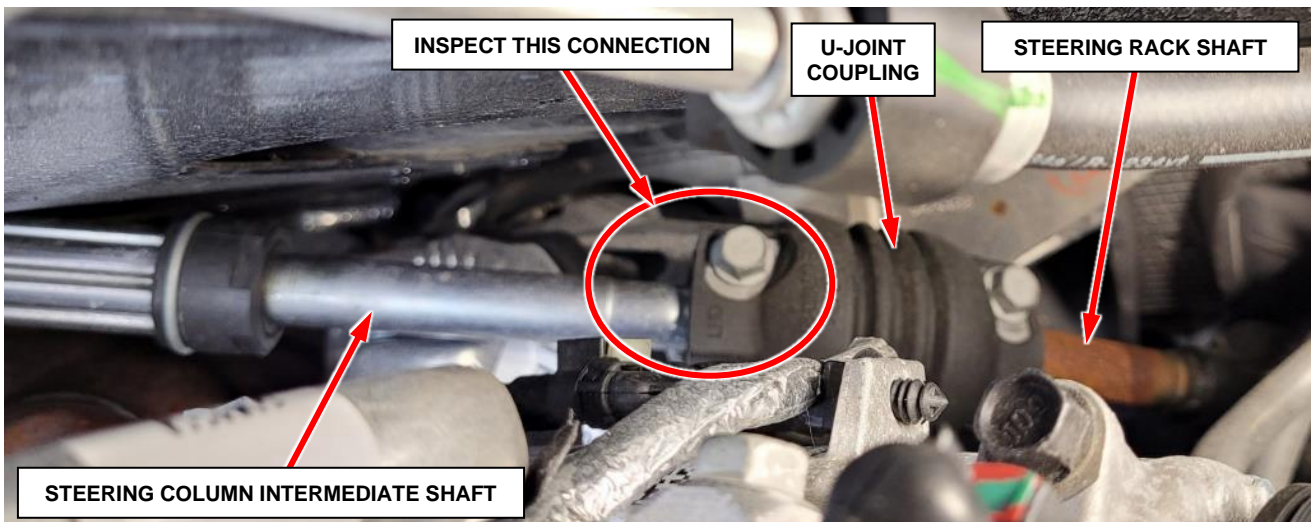
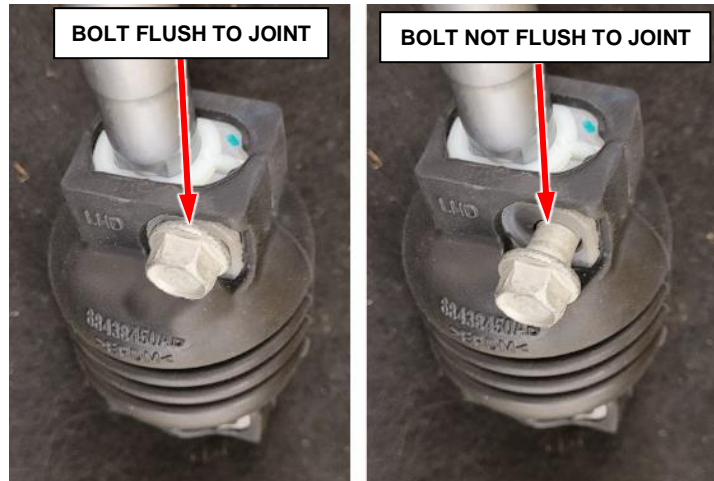

Figure 3 – Locate Suspect Steering Connection

5. Perform the following inspections (a-c) of the U-joint coupling upper connection:

- a) Does the U-joint coupling upper bolt appear to be fully tightened flush against the U-joint coupling or not fully tightened? (Figure 4).



Bolt Fully Flush **Bolt NOT Fully Flush**

Figure 4 – Inspect Bolt Flushness with U-Joint Connection

- b) Is the white spacer clip present or missing? (Figure 5).

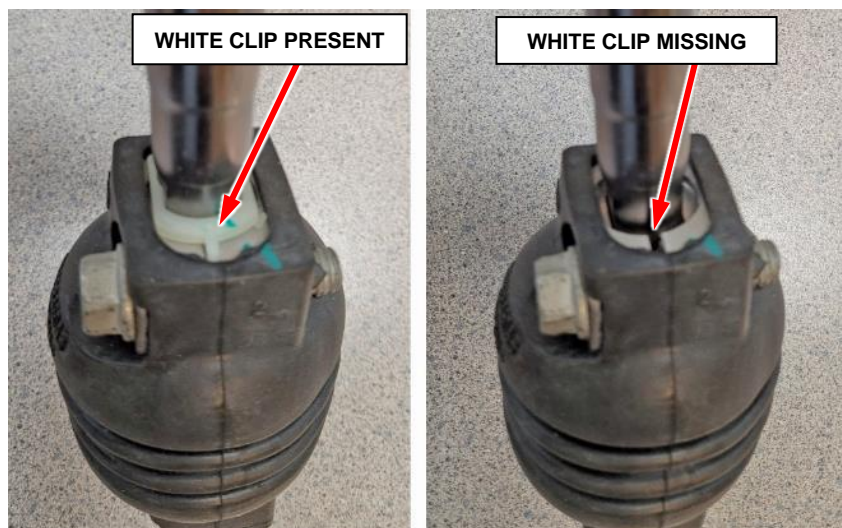

White Clip Present **White Clip MISSING**

Figure 5 – Inspect for White Clip at U-Joint Connection

SAFETY RECALL

NORTH AMERICA

Intermediate Shaft



Reference: 58A / NHTSA 23V-352

FCA US LLC

- c) Is the intermediate shaft fully inserted into the U-joint coupler with I-shaft stop lip touching the white plastic clip or not fully inserted? (Figure 6).

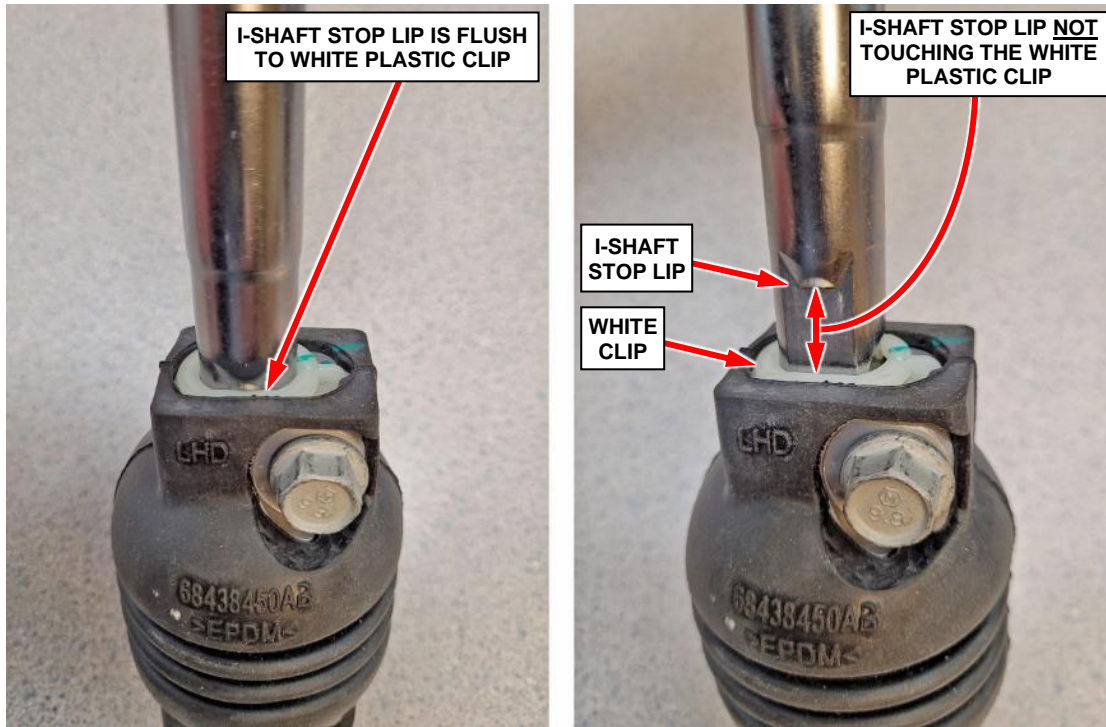

Shaft Inserted to Clip

Shaft NOT Fully Inserted to Clip

Figure 6 – Inspect Intermediate Shaft Fully Inserted Into U-Joint Coupler

6. Do **ANY** of the identified conditions (a-c) exist:
- a) Bolt is NOT fully tightened flush to U-joint coupling.
 - b) White plastic clip is MISSING.
 - c) Intermediate shaft is NOT fully inserted into the U-joint coupling.

YES >>> One or more of the above conditions (a-c) exist, proceed to the **Repair Procedure**.

NO >>> Install any components removed during inspection and return vehicle to customer or inventory.

- If wheel was removed to perform inspection, tighten the lug nuts to 176 N·m (130 Ft-Lbs).

SAFETY RECALL

NORTH AMERICA

Intermediate Shaft



Reference: 58A / NHTSA 23V-352

FCA US LLC

B. Repair Procedure

CAUTION: Anytime the Steering Column Control Module (SCCM) is mounted on the steering column the steering shaft must be kept from turning or else SCCM damage will occur. Some vehicles do not have an internal lock mechanism, so the steering column shaft must be preventing from rotating through use of a suitable tool.

1. Secure the steering wheel to prevent it from turning.
2. For Plugin Hybrid Electric Vehicles (PHEV) Engine (Sales Code ECX) perform a High Voltage Power Down:

NOTE: If vehicle is NOT a PHEV Step 2 may be skipped.

WARNING: Before performing any diagnostic or service procedure, you must thoroughly read and follow all applicable high voltage safety procedures.

- a) Prepare the work area and familiarize yourself with all HIGH-VOLTAGE SAFETY PROCEDURES related to personal safety and vehicle safety associated with working on a Plug-In Hybrid Electric Vehicle (PHEV) (Within Service Library, Refer to 12 - Electrified Powertrain System/High Voltage Battery/Standard Procedure).
- b) Inspect all orange high voltage cables, and high voltage components labeled with the high voltage symbol for physical damage. If damage is present, extra caution must be taken to avoid contact with unprotected high voltage. Do not insert probes, tools, objects or fluids into damaged high voltage cables or components.
- c) Disconnect any charging equipment. Do not plug in the EVSE Recharge Coupler when working on the vehicle.
- d) Verify that the Keyless Go button (1) is indicating that the ignition is in the OFF position. If not, press the button to toggle to OFF mode (Figure 7).
- e) Remove the cargo floor cover (1) (Figure 8).



Figure 7 – Keyless Go Button



Figure 8 – Cargo Floor Cover

SAFETY RECALL

NORTH AMERICA

Intermediate Shaft



Reference: 58A / NHTSA 23V-352

FCA US LLC

- f) Remove the fastener (1) then remove the High Voltage Test and Service Module (HVTSM) cover (2) (Figure 9).

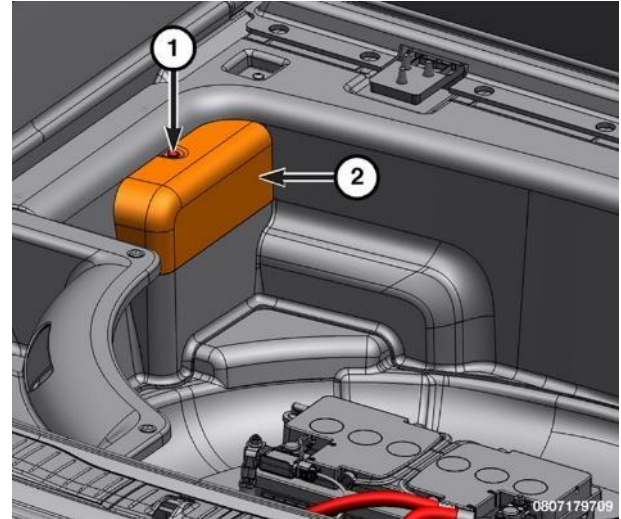

Figure 9 – HVTSM Cover

- g) Use of an insulation tester such as the Fluke Meter, Multi 126-1587 is recommended for PHEV circuit testing (Figure 10). Perform the multi-meter functionality tests per the manufacturer's directions. If at any point during the procedure, the multi-meter settings are changed, or the probes are repositioned in the meter, verification with a known good power source must be repeated. **Always observe these precautions prior to taking a high voltage measurement:**



Figure 10 – PHEV Circuit Testing

- Use known good test leads.
- Verify the multi-meter leads are rated "CAT III 1,000V". This should be printed on the multi-meter leads.
- Install the multi-meter leads in the BLACK and RED sockets on the right side of the Fluke 1587 (VΩ (RED) and COM (BLACK)).
- Test the multi-meter operation by measuring the voltage across the 12-volt Battery.
- Switch the FLUKE 1587 to the DC Volts selection and press the RANGE button until the 1000V range is selected - just one digit (a zero) is displayed.

SAFETY RECALL

NORTH AMERICA

Intermediate Shaft



Reference: 58A / NHTSA 23V-352

FCA US LLC

h) This next step is being performed to confirm that we can measure voltage present through the wiring to the test point connector. Remove the HVIL cover from the orange test point connector and connect the High Voltage Test Adapter 2077100080 into the orange test point connector. There are two test adaptors in the kit. The difference is explained below:

- Test adaptor with **orange insulation** - This adaptor comes with the HVIL loop in the connector.
- Test adaptor with **blue insulation** - This adaptor does not have the HVIL loop in the connector.

Connect the **Orange** test adapter with the HVIL loop to the orange test point connector. The Orange high voltage test connector is used to measure the voltage on the HV cables after the HV battery contactors to confirm power down. These circuits are sense circuits connected through very large resistors inside the high voltage battery to the high voltage bus cables after the contactors. **These circuits are safe even when high voltage is present on the circuits due to the large resistors reducing these circuits to milliamperes** (Figure 11).

i) Insert the red and black test adapter probes into the right multi-meter ports matching the colors (Figure 12).

- Press the ignition ON.
- With the scan tool, erase all DTCs.
- Press the ignition OFF.
- Remove the scan tool from the DLC.
- Close all the doors.
- Perform sleep cycle. (Wait until the cluster display goes blank).
- Press the ignition ON.

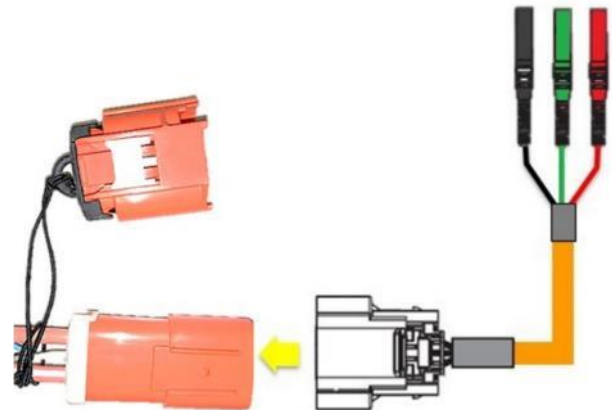

Figure 11 – High Voltage Test Adapter



Figure 12 – PHEV Circuit Testing

SAFETY RECALL

NORTH AMERICA

Intermediate Shaft



Reference: 58A / NHTSA 23V-352

FCA US LLC

- j) Select the volt meter to DC volts, range the meter to whole numbers (no decimal points) and read the battery pack voltage (Figure 12).
- If the volt meter shows over 300 volts, the HV system is powered up and the HV sense circuits from the Battery Pack are not open to the Orange HV test point. Continue to the next step to power down the HV battery.
 - If the voltage is reading 0 volts, **Assume that the HV Battery Pack is powered up and the HV sense circuits are open from the battery pack to the Orange HV test point connector. Disconnect the green High Voltage Disabling and Lockout (HVDL) connector, check the HV sense circuits for opens, repair or replace as necessary and retest. If the sense circuits test good the HV Battery Pack requires replacement. The battery pack should be handled the same as a pack with welded contactors. Reference the HV BATTERY SERVICING WITH WELDED CONTACTOR(S) procedure at the top of the HV PHEV BATTERY REMOVAL AND INSTALLATION procedure for safely removing a high voltage battery that will not power down (Within Service Library, Refer to 12 - Electrified Powertrain System/High Voltage Battery/BATTERY/Removal and Installation).**
- k) Press the Keyless Go button to toggle to OFF mode. To ensure that the HV system stays powered down, move the keys at least 20 feet away from the vehicle.

NOTE: The Green connector is the HVDL connector. The HV battery internal HVIL loop circuit passes through this connector, out to the orange high voltage disconnect test connector cover, and back through the HVDL connector again (Figure 13).

- l) To open the High Voltage Disabling and Lockout (HVDL) connector, lift the red CPA lock tab on the black portion of the green HVDL connector. Using a small screwdriver or probe, lift the lock arm as shown and lift the black portion of the device until the padlock hole is completely exposed. When the center safety lockout loop of the connector is raised, a hole for a safety lock is exposed.

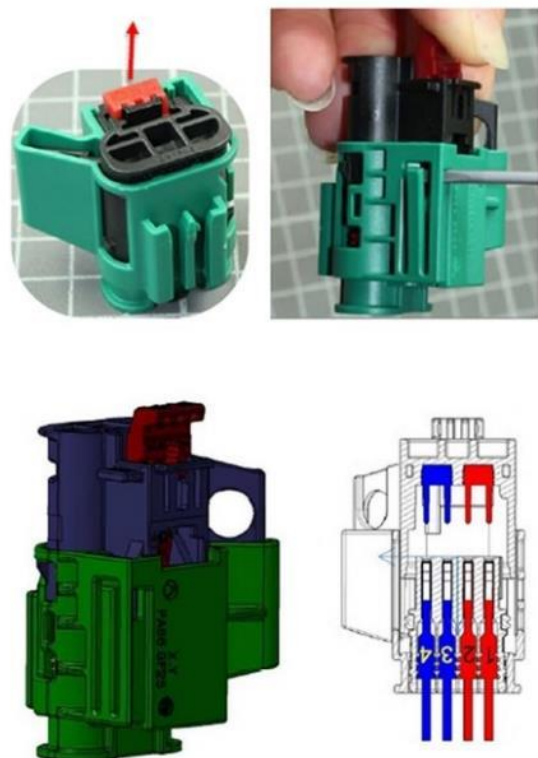

Figure 13 – HVDL Connector

SAFETY RECALL

NORTH AMERICA

Intermediate Shaft



Reference: 58A / NHTSA 23V-352

FCA US LLC

m) The voltage reading on the multi-meter should change to 0 volts with the green HVDL connector open. (Some residual voltage may be present, up to 2.0 volts may be normal) (Figure 14).

- 1) Next, remove the black test harness lead from the black multi-meter socket and connect a good lead between chassis ground and the black multi-meter socket and monitor the voltage. Meter should read 0 volts. This is testing for voltage from a stuck contactor on the HV battery + cable at the test point connector.
- 2) Lastly, switch the red and black leads at the multi-meter and monitor the voltage. Meter should read 0 volts. This is testing for voltage from a stuck contactor on the HV battery – cable at the test point connector.



Figure 14 – PHEV Circuit Testing

- If the voltage measured is below 2.0 volts for each measurement, the HV battery is powered down and it is safe to work on the high voltage components with the exception of the high voltage battery internal components. Continue to the next step to power down of the 12-volt system. This will prevent any possibility of the HV battery being powered up.
- If the voltage is greater than 50 volts, an internal condition exists within the high voltage battery such as stuck contactors, that are preventing it from being powered down. This should be accompanied by contactor stuck DTCs. Do not attempt to carry out testing on any of the vehicle's high voltage components or wiring. The HV Battery Pack requires replacement. Reference the HV BATTERY SERVICING WITH WELDED CONTACTOR(S) procedure at the top of the HV PHEV BATTERY REMOVAL AND INSTALLATION procedure for safely removing a high voltage battery that will not power down (Within Service Library, Refer to 12 - Electrified Powertrain System/High Voltage Battery/BATTERY/Removal and Installation).
- If the voltage is between 2.0 volts and 50 volts, the HV system is safe to work on, however there is a problem that should be diagnosed. Put on PPE safety equipment and disconnect each of the following HV modules one at a time and check the voltage at the test points. If the voltage drops to 2.0 volts or less, the faulted module has been found. Reconnect each module before continuing to the next.
 - Integrated Dual Charger Module (IDCM)
 - Electronic A/C Compressor (EAC)
 - Battery Coolant Heater
 - HV Coolant Heater
 - Power Inverter Module (PIM)

SAFETY RECALL

NORTH AMERICA

Intermediate Shaft



Reference: 58A / NHTSA 23V-352

FCA US LLC

- n) Insert a wire tag, holding pin or padlock into the service lockout loop to be certain that the connector (1) remains open. The HV system is now powered down. The 12-volt system should be powered down also to make certain that the HV battery cannot be powered back up. Continue to the next step to complete the power down procedure (Figure 15).



Figure 15 – Service Lockout Loop

- o) Remove the 12-volt cable (1) from the front lug (2) of the fuse array on the front PDC. Immediately cover the exposed end with an insulating cap from the Covers, HEV Battery Terminal 2035100082. If a cover is not available, a finger from an old insulated safety glove can be cut out and used to cover the terminal. This will remove the power source that supplies the contactors inside the high voltage battery but not completely power down the 12-volt system. If there is a 12-volt cable connected to rear lug (number 6), remove and cover it as well (Figure 16).

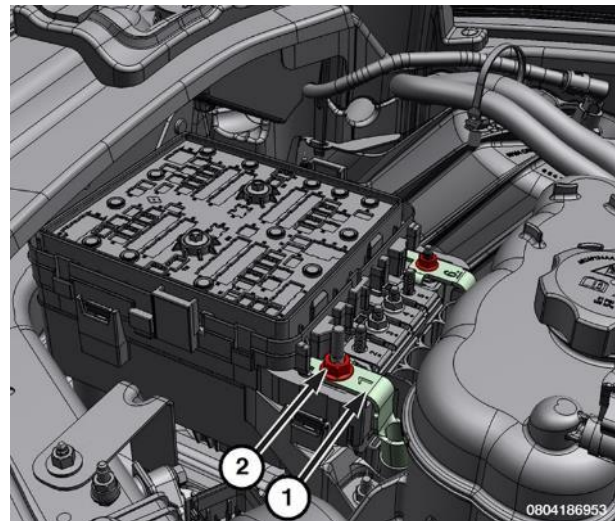

Figure 16 – 12-Volt Cable at PDC

SAFETY RECALL

NORTH AMERICA

Intermediate Shaft



Reference: 58A / NHTSA 23V-352

FCA US LLC

- p) To completely power down the 12-volt system, remove the rear access panel (1) to expose the rear PDC (Figure 17).

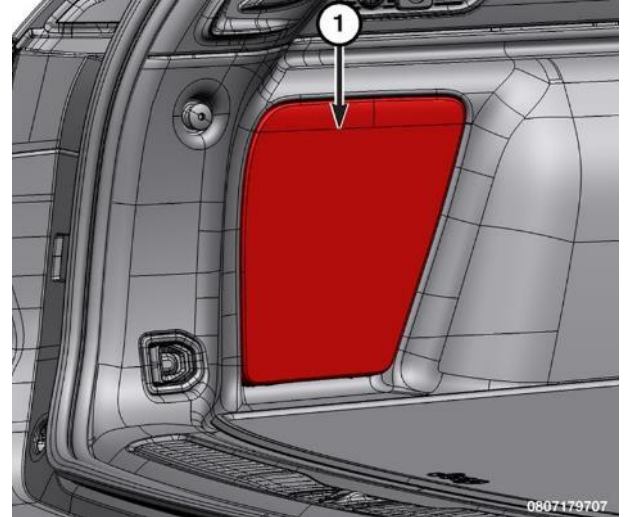

Figure 17 – Rear PDC Access Panel

- q) Remove the 12-volt fastener (1) and cable (2) from the rear PDC and cover the exposed end with an insulating cap from the Covers, HEV Battery Terminal 2035100082. If a cover is not available, a finger from an old insulated safety glove can be cut out and used to cover the terminal. The 12-volt system should be powered down completely (Figure 18).

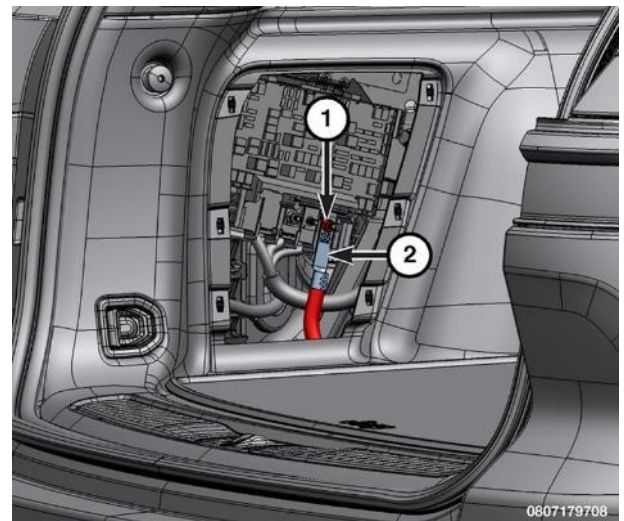

Figure 18 – 12-Volt Cable at Rear PDC

3. For vehicles equipped with the following:
- **2.0L PHEV Engine (Sales Code ECX) with RHD or LHD steering.**
 - **2.0L Turbo Engine (Sales Code EC1) with LHD steering.**
 - **3.6L (Sales Code ERC) RHD steering.**

Belly pan removal will be necessary to access the U-joint coupling (Figure 19).

NOTE: Engine and Steering combinations other than those listed above will not require this step.

- a) Raise and support the vehicle.
- b) Remove the belly pan fasteners and belly pan.



Figure 19 – Belly Pan

4. For vehicles equipped with the following:
- **3.6L (Sales Code ERC) with LHD steering.**
 - **5.7L Engine (Sales Code EZH) with LHD steering.**

Engine cover and air cleaner housing assembly removal will be necessary to access the U-joint coupling (Figure 20).

NOTE: Engine and Steering combinations other than those listed above will not require this step.

- a) Disconnect and isolate the battery negative cable.
- b) Remove the engine cover.
- c) Remove the air cleaner resonator.
- d) Remove the air cleaner housing assembly.



Figure 20 – Engine Cover and Air Cleaner Housing Assembly

SAFETY RECALL

NORTH AMERICA

Intermediate Shaft



Reference: 58A / NHTSA 23V-352

FCA US LLC

5. Remove the upper steering column shaft U-joint coupling pinch bolt and examine the bolt threads for any damage then **DISCARD** the bolt (Figure 21).

- **Bolt Threads Damaged:** The U-Joint coupling will require replacement. Contact campaign team as directed in the parts section to order the appropriate parts then continue to **Step 6** of repair procedure.
- **Bolt Threads NOT Damaged:** U-Joint coupling may be reused. U-joint coupling replacement step may be skipped. Contact campaign team as directed in the parts section to order the appropriate parts then continue to **Step 7** of the repair procedure.



Figure 21 – Inspect Bolt Threads

6. U-joint coupling replacement is **ONLY** necessary if bolt thread in previous step were damaged. If bolt threads were **NOT** damaged, skip this step for U-joint coupling replacement (Figure 22).

U-joint coupling replacement procedure:

- a) Grasp the I-shaft near the U-joint coupling then slide the I-shaft back into itself releasing it from the U-joint coupling (Figure 23).
- b) Remove and **DISCARD** the lower steering column shaft coupling pinch bolt (1) (Figure 22).
- c) Remove and **DISCARD** the U-joint coupling from the steering gear shaft.
- d) Obtain a **NEW** U-joint coupling and install it to the steering gear shaft.
- e) Obtain a **NEW** pinch bolt and install it in the U-joint coupling lower hole (1) then tighten the bolt to 45 N·m (33 Ft. Lbs.) (Figure 22).
- f) Slide the I-shaft back into the U-joint coupling inserting the I-shaft fully into the U-joint coupling as far as it will go. The white plastic clip will act as a stop (Figure 23).
- g) Proceed to the next step of the repair procedure.

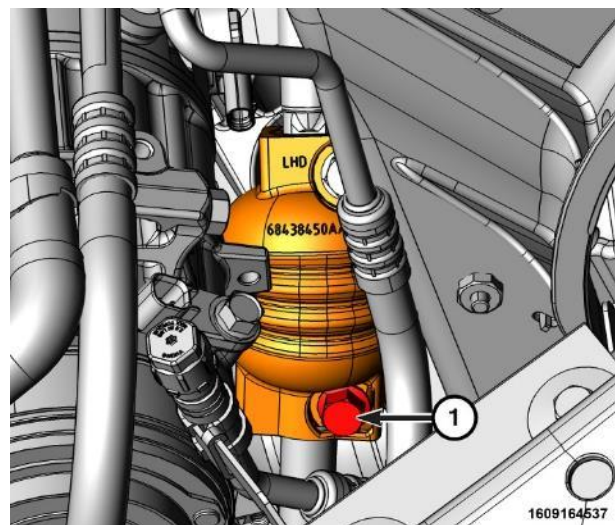

Figure 22 – U-Joint Coupling

SAFETY RECALL

NORTH AMERICA

Intermediate Shaft



Reference: 58A / NHTSA 23V-352

FCA US LLC

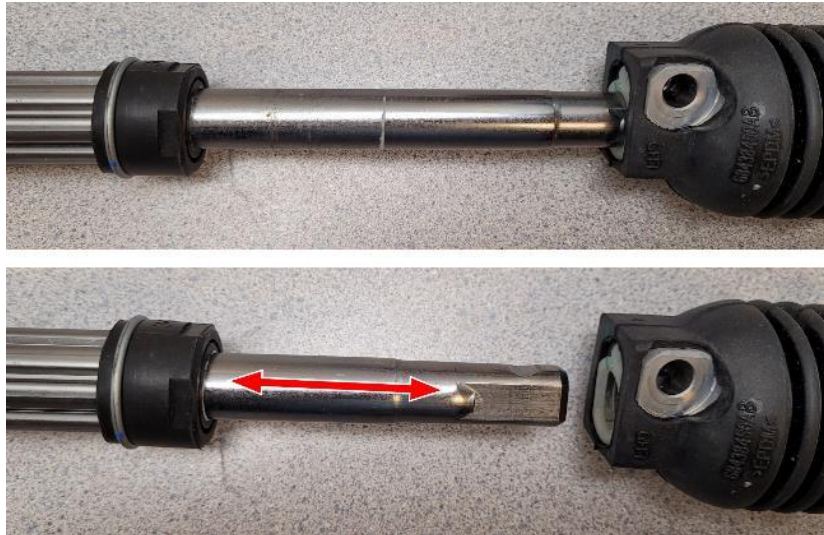

Figure 23 – Slide Intermediate Shaft In - Out for Service

7. Is the white plastic clip present or missing from the U-joint coupling? (Figure 24)

- **White Plastic Clip Present:** Continue to next step of repair procedure.
- **White Plastic Clip Missing:** Obtain a **NEW** white plastic clip and follow these instructions.

Install the **NEW** white plastic clip to U-joint coupling:

- Grasp the I-shaft near the U-joint coupling then slide the I-shaft back into itself releasing it from the U-joint coupling (Figure 23).
- Install the white plastic clip to the U-joint coupling (Figure 24).
- Slide the I-shaft back into the U-joint coupling inserting the I-shaft fully into the U-joint coupling as far as it will go. The white plastic clip will act as a stop (Figure 23).
- Proceed to the next step of the repair procedure.

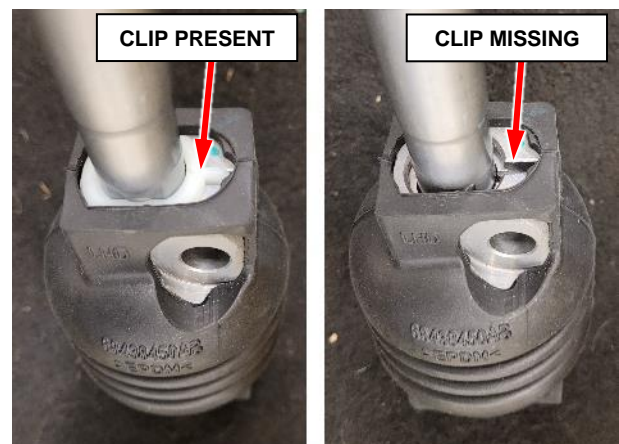

Figure 24 – White Plastic Clip

SAFETY RECALL

NORTH AMERICA

Intermediate Shaft



Reference: 58A / NHTSA 23V-352

FCA US LLC

8. The I-shaft needs to be fully inserted into the U-joint coupling until the stop lip on the I-shaft contacts the white plastic clip (Figure 25). If the I-shaft stop lip is not contacting the white plastic clip, grasp the I-shaft near the U-joint coupling then attempt to insert the I-shaft fully into the U-joint until the stop lip contacts the white plastic clip. Can the shaft be fully inserted?

- **I-Shaft Stop Lip Contacts White Plastic Clip:**
Continue to **Step 10** of repair procedure.
- **I-Shaft Stop Lip NOT Contacting White Plastic Clip and CANNOT Be Inserted Further:**
Intermediate shaft is oversize. Obtain a **NEW** intermediate shaft then follow these instructions.

For vehicles equipped with the following:

- 2.0L PHEV Engine (Sales Code ECX) with RHD or LHD steering.
- 2.0L Turbo Engine (Sales Code EC1) with LHD steering.
- 3.6L (Sales Code ERC) RHD steering.

Remove the upper cowl extension silencer as follows:

NOTE: Engine and Steering combinations other than those listed above will NOT require cowl extension silencer removal. All others may proceed directly to Step 9 for replacement of intermediate shaft.

- a) Disconnect and isolate the battery negative cable if not done previously.

NOTE: PHEV vehicles should already be powered down.

- b) Lift the cap (1) and remove the wiper arm fastener (Figure 26).
- c) Put the arm in the service up position, then use a slight fore/aft rocking action to loosen the wiper arm from the pivot shaft and remove the wiper arm. If required, use appropriate tool to remove the wiper arm from the pivot shaft.

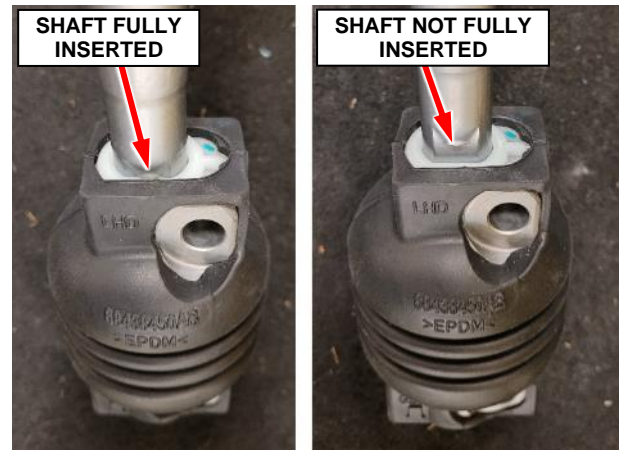

Fully Inserted

Not Fully Inserted

Figure 25 – Intermediate Shaft Insertion Into U-Joint Coupling

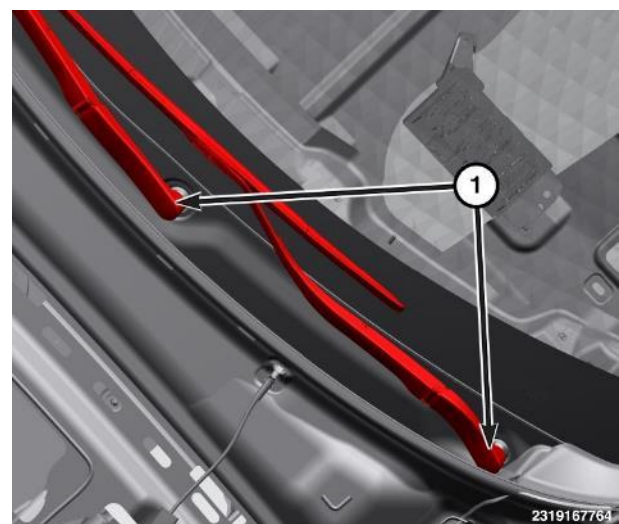

Figure 26 – Wiper Arms

SAFETY RECALL

NORTH AMERICA

Intermediate Shaft



Reference: 58A / NHTSA 23V-352

FCA US LLC

- d) Using a trim stick, release the clips from under the rear edge of the front fender (3) and the cowl trim (2) (Figure 27).
- e) Separate the cowl end caps (1) (Figure 27).

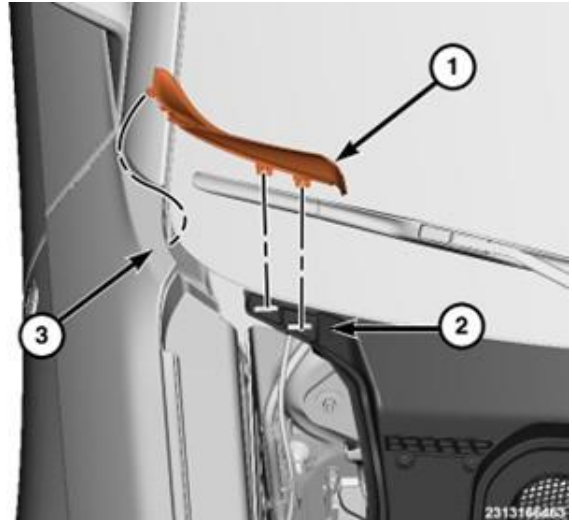

Figure 27 – Cowl Trim

- f) Release the push-pin fasteners (1) and remove the corner foam seals (Figure 28).

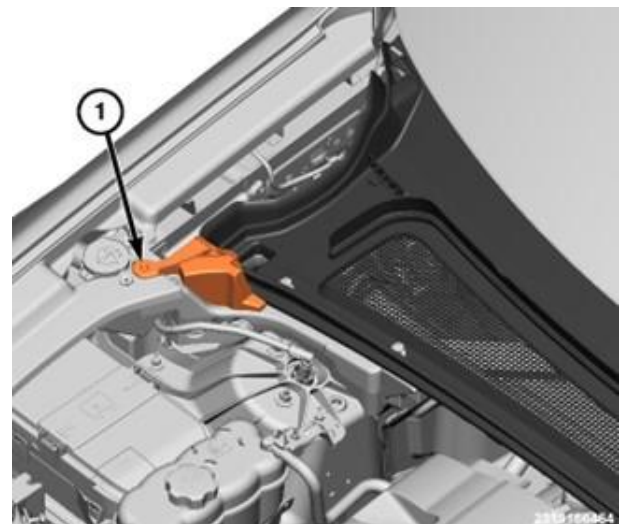

Figure 28 – Foam Seal

SAFETY RECALL

NORTH AMERICA

Intermediate Shaft



Reference: 58A / NHTSA 23V-352

FCA US LLC

CAUTION: Use care when working with the retaining channel on the bottom of the windshield. If the retaining channel is damaged the windshield retainer will require replacement.

- g) Remove the push-pin fasteners (1) (Figure 29).
- h) Lift the front of the cowl panel cover and carefully pull it forward releasing it from the windshield retainer channel.
- i) Remove the cowl panel cover from the vehicle.

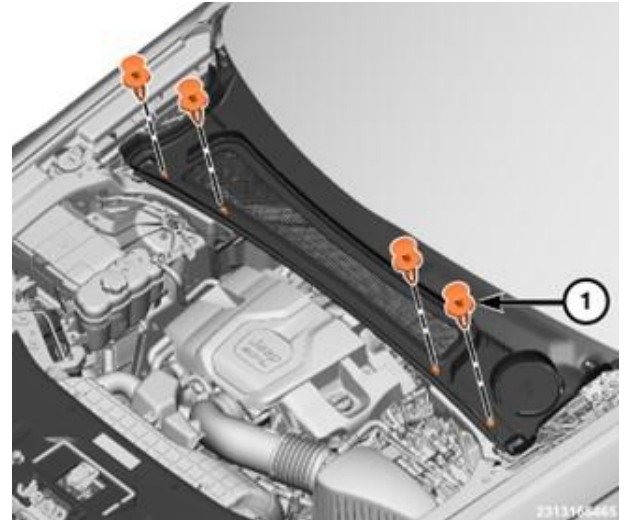

Figure 29 – Cowl Panel

- j) Remove the fasteners (1) that secure the front wiper linkage module to the cowl plenum (Figure 30).
- k) Disconnect the wire harness connector from the connector receptacle for the front wiper motor.
- l) Remove the front wiper linkage module from the cowl plenum as a unit.

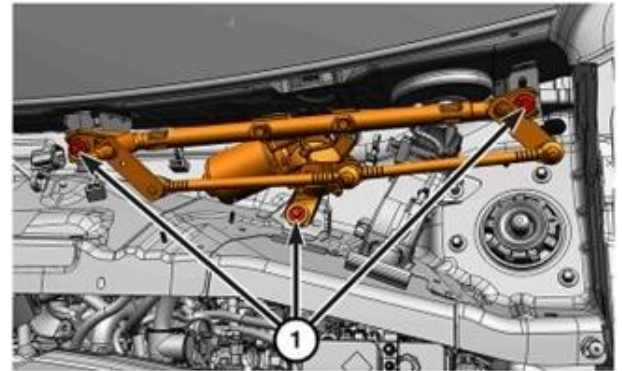

Figure 30 – Wiper Linkage Assembly

SAFETY RECALL

NORTH AMERICA

Intermediate Shaft



Reference: 58A / NHTSA 23V-352

FCA US LLC

- m) Remove the fasteners (1) and remove the foam seals (2) from each side (Figure 31).

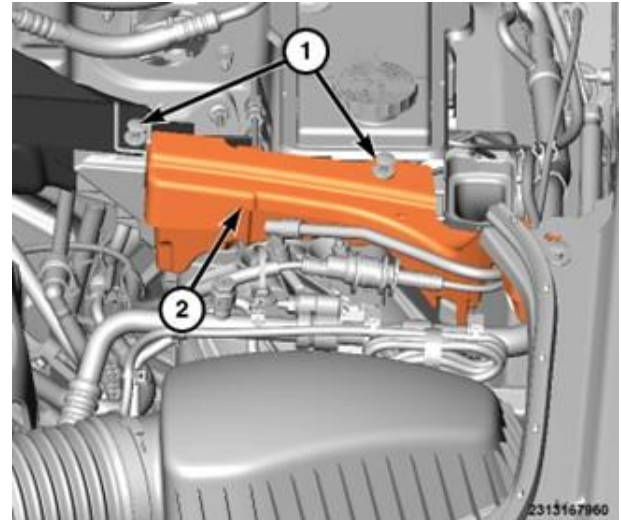

Figure 31 – Foam Seal

- n) Remove the shock tower brace nuts (2) and the bolts (1) (Figure 32).
- o) Remove the upper cowl extension silencer fasteners (3) (Figure 32).
- p) Remove the upper cowl extension silencer and the shock tower brace as an assembly (4) (Figure 32).

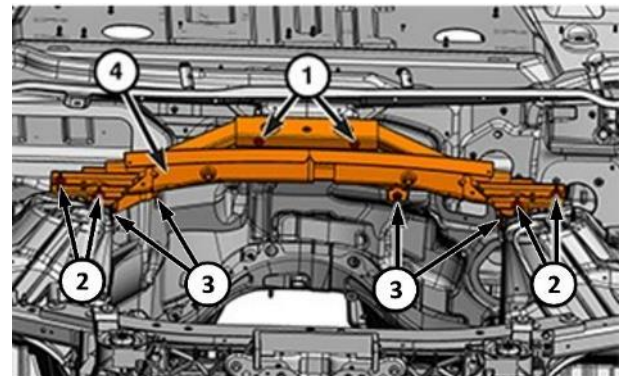

Figure 32 – Upper Cowl Extension

- q) Proceed to the next step of the repair procedure.

SAFETY RECALL

NORTH AMERICA

Intermediate Shaft



Reference: 58A / NHTSA 23V-352

FCA US LLC

9. Intermediate shaft replacement is **ONLY** necessary if I-shaft cannot be fully inserted into the U-joint coupling as determined in previous step of this procedure. If I-shaft can be fully inserted into the U-joint coupling, skip this step for I-shaft replacement.

Intermediate shaft replacement steps as follows:

- a. Remove and **DISCARD** the intermediate shaft pinch bolt (1) (Figure 33).
- b. Remove and **DISCARD** the intermediate shaft.
- c. Obtain and install a **NEW** intermediate shaft using a **NEW** pinch bolt tightened to 45 N·m (33 Ft. Lbs.).

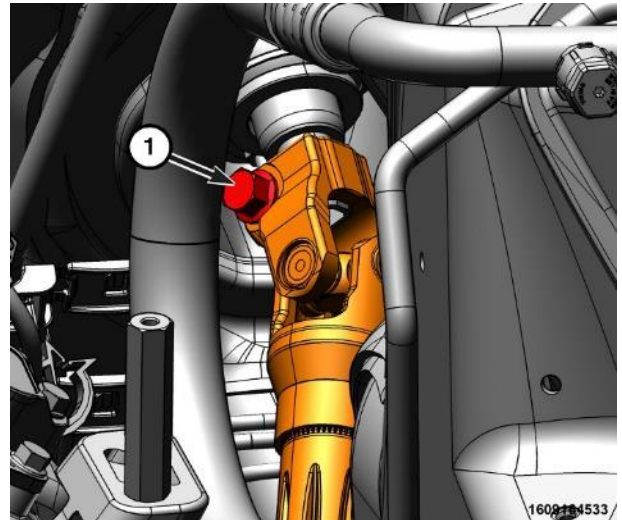

Figure 33 – Intermediate Shaft

Only for those vehicles which cowl extension silencer was removed to access the intermediate shaft, reassemble cowl extension silencer in reverse order of removal. Otherwise proceed to the next step of the repair procedure.

Cowl extension silencer installation steps are as follows:

- a. Cowl extension silencer fasteners (3) M6 tighten to 8 N·m (71 In. Lbs.) (Figure 32).
- b. Shock tower brace bolts M6 (1) tighten to 8 N·m (71 In. Lbs.) (Figure 32).
- c. Shock tower brace nuts M6 (2) tighten to 7 N·m (62 In. Lbs.) (Figure 32).
- d. Foam seal (2) and fastener (1) (Figure 31).
- e. Wiper Linkage Module Bolts (1) tighten to 5 N·m (44 In. Lbs.) (Figure 30).
- f. Cowl Panel and fasteners (1) (Figure 29).
- g. Foam seal and push-pin fastener (1) (Figure 28).
- h. Cowl trim (1) (Figure 27).
- i. Wiper arms and nuts (1) tighten to 23 N·m (17 Ft. Lbs.) (Figure 26).
- j. Proceed to the next step of the repair procedure.

SAFETY RECALL

NORTH AMERICA

Intermediate Shaft



Reference: 58A / NHTSA 23V-352

FCA US LLC

10. Ensure the I-Shaft is fully inserted into the U-joint coupling so that stop is resting against the white plastic clip (Figure 34).
11. Obtain a **NEW** pinch bolt and install it to the U-joint coupling upper hole (1) then tighten the bolt to 45 N·m (33 Ft. Lbs.) (Figure 34).

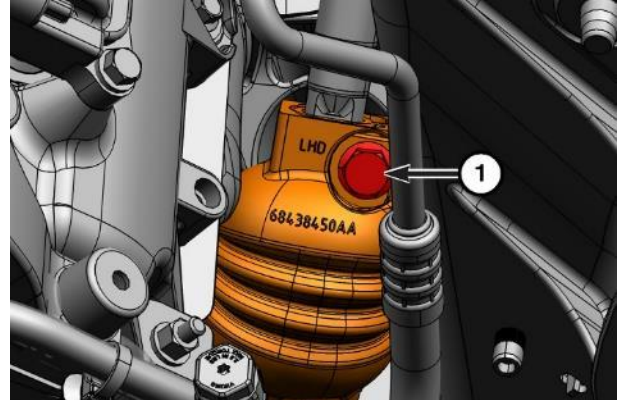

Figure 34 – U-Joint Coupling Upper Bolt

12. For vehicles which engine cover and air cleaner housing assembly was removed (Figure 20):
 - a) Install the air cleaner housing assembly.
 - b) Install the air cleaner resonator.
 - c) Install the engine cover.
13. For vehicles which belly pan was removed. Install the belly pan and belly pan fasteners (Figure 19).
14. For vehicles which the front wheel assembly was removed. Install the wheel assembly and tighten the lug nuts to 176 N·m (130 Ft-Lbs).
15. For non-PHEV vehicles which the battery negative cable was disconnected, it may be reconnected now.

SAFETY RECALL

NORTH AMERICA

Intermediate Shaft



Reference: 58A / NHTSA 23V-352

FCA US LLC

16. For PHEV vehicles which were powered down, follow the power up procedure:

- a) Remove the high voltage test adapter from the orange high voltage disconnect test connector.
- b) Remove the lockout device from the service lockout loop of the green High Voltage Disabling and Lockout (HVDL) connector at the High Voltage Test and Service Module (HVTSM) (Figure 35).
- c) Using a small screwdriver or probe, release the green locking lever and depress the black jumper fully back into the socket (Figure 35).
- d) Depress the red CPA lock (Figure 35).
- e) Replace the cover on the orange test point connector of the HVTSM (Figure 35).
- f) Install the cover over the HVTSM and secure the fastener (Figure 9).
- g) Install the cargo floor cover (Figure 8).
- h) Remove the cap and connect the 12-volt cable to the rear PDC. Tighten the cable nut to 8 N·m (71 In. Lbs.) (Figure 18).
- i) Install the rear PDC access cover (Figure 17).
- j) Remove the cap and connect the 12-volt cable to the front lug of the fuse array on the front PDC. Tighten the cable nut to 15 N·m (11 Ft. Lbs.) (Figure 16).
- k) Install the PDC cover.
- l) Test the vehicle functionality:
 - Retrieve the key fob
 - With the vehicle in PARK, a driver in the seat, and the brake pedal depressed, press the Keyless Go button.

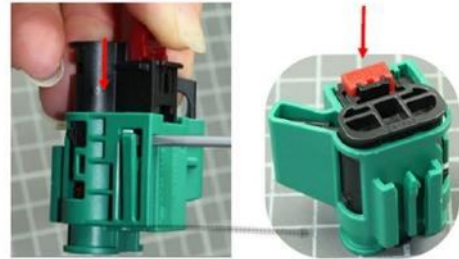

Figure 35 – HVDL

If the vehicle enters RUN mode without error, power-up has been successful. If the message "Service High Voltage System" appears on the dash cluster display, recheck the seating of both connectors of the HVTSM after keying-off, and then try again. If the error persists, power down the high voltage system and begin diagnostics.

17. Lower the vehicle and close engine compartment hood.

18. Return the vehicle to customer or inventory.

This notice applies to your vehicle,

[Model Year and Model]

VIN XXXXXXXXXXXXXXXXXXXX

58A/NHTSA 23V- 352

LOGO

VEHICLE PICTURE

YOUR SCHEDULING OPTIONS

- 1. RECOMMENDED OPTION**
Call your authorized Chrysler / Dodge / Jeep® / RAM Dealership
- 2. Call the FCA Recall Assistance Center at 1-800-853-1403. An agent can confirm part availability and help schedule an appointment**
- 3. Visit recalls.mopar.com, scan the QR code below, or download the Mopar Owner's Companion App.**

QR Code

Get access to recall notifications, locate your nearest dealer, and more through this website or Mopar Owner's Companion App. You will be asked to provide your Vehicle Identification Number (VIN) to protect and verify your identity. The last eight characters of your VIN are provided above.

DEALERSHIP INSTRUCTIONS

Please reference Safety Recall 58A.

IMPORTANT SAFETY RECALL

Intermediate Shaft

Dear [Name],

This notice is sent to you in accordance with the National Traffic and Motor Vehicle Safety Act.

FCA US LLC has decided that a defect, which relates to motor vehicle safety, exists in certain [2021 through 2023 model year (WL) Jeep Grand Cherokee and Grand Cherokee L] vehicles.

It is extremely important to take steps now to repair your vehicle to ensure the safety of you and your passengers.

WHY DOES MY VEHICLE NEED REPAIRS?

Your vehicle ^[1] may have been built with an incorrectly assembled steering column intermediate shaft which may potentially disconnect from the U-joint. The driver may notice play in steering and/or noise when turning prior to the intermediate shaft disconnecting. **A disconnected intermediate shaft may result in a loss of steering control which can cause a vehicle crash without prior warning.**

HOW DO I RESOLVE THIS IMPORTANT SAFETY ISSUE?

FCA US will repair your vehicle ^[2] free of charge (parts and labor). To do this, your dealer will inspect and, if necessary, replace the intermediate shaft and assembly parts. The estimated time is about 30 minutes for inspection or longer to complete if component replacement is necessary. In addition, your dealer will require your vehicle for proper check-in, preparation, and check-out during your visit, which may require more time. Your time is important to us, so we recommend that you schedule a service appointment to minimize your inconvenience. Please bring this letter with you to your dealership.

**TO SCHEDULE YOUR FREE REPAIR,
CALL YOUR CHRYSLER, DODGE, JEEP OR RAM DEALER TODAY**

WHAT IF I ALREADY PAID TO HAVE THIS REPAIR COMPLETED?

If you have already experienced this specific condition and have paid to have it repaired, you may visit www.fcarecallreimbursement.com to submit your reimbursement request online. ^[3] Once we receive and verify the required documents, reimbursement will be sent to you within 60 days. If you have had previous repairs performed and/or already received reimbursement, you may still need to have the recall repair performed.

We apologize for any inconvenience, but are sincerely concerned about your safety. Thank you for your attention to this important matter.

Customer Assistance/Field Operations
FCA US LLC



Mr. Mrs. Customer
1234 Main Street
Hometown, MI 48371

[1] If you no longer own this vehicle, please help us update our records. Call the FCA Recall Assistance Center at 1-800-853-1403 to update your information.

[2] If your dealer fails or is unable to remedy this defect without charge and within a reasonable time, you may submit a written complaint to the Administrator, National Highway Traffic Safety Administration, 1200 New Jersey Ave., S.E., Washington, DC 20590, or you can call the toll-free Vehicle Safety Hotline at 1-888-327-4236 (TTY 1-800-424-9153), or go to safercar.gov.

[3] You can also mail in your original receipts and proof of payment to the following address for reimbursement consideration: FCA Customer Assistance, P.O. Box 21-8004, Auburn Hills, MI 48321-8007, Attention: Recall Reimbursement.

Note to lessors receiving this recall notice: Federal regulation requires that you forward this recall notice to the lessee within 10 days.