



Technical Service Bulletin

GROUP	NUMBER
RECALL	23-01-053G
DATE	MODEL(S)
JUNE 2023	GV60 (JW1)

SUBJECT:	REAR INTEGRATED DRIVE AXLE (IDA) SHAFT REPLACEMENT (RECALL CAMPAIGN 014G)
-----------------	--

★ IMPORTANT

Vehicle repairs related to safety recalls are critically important and must be performed properly in accordance with TSB procedures. Review this bulletin in its entirety prior to beginning any repair work.

As required by federal law, dealers must not deliver new vehicles for sale or for lease to customers until all open recalls have been performed. Dealers must also perform all open recalls on used vehicles, demo, and rental vehicles prior to placing them into customer use and whenever an affected vehicle is in the shop for any maintenance or repair.

Access the "Vehicle Information" screen via WEBDCS to identify open recalls.

Description: Certain GV60 (JW1) vehicles are equipped with all-wheel drive powertrain systems containing rear driveshafts that could potentially fracture due to abnormal stress incurred by improper jig alignment during manufacturing. A fractured driveshaft could result in a sudden reduction of motive power, increasing the risk of a crash. This bulletin describes the procedure to replace the rear driveshafts with a revised part.



Applicable Vehicles (Certain):

- 2023MY GV60 (JW1) produced from 06/15/2022 – 02/10/2023

i Information

This recall campaign for GV60 (JW1) can only be performed by EV certified Genesis retailers.

**SUBJECT: REAR INTEGRATED DRIVE AXLE (IDA) SHAFT REPLACEMENT
(RECALL CAMPAIGN 014G)**

Table of Contents

Parts Information: 2

Special Service Tools (SST):..... 3

Warranty Information:..... 3

Service Procedure:..... 4

Guided Video Information 4

Rear IDA (Integrated Drive Axle) Removal 4

Joint Removal 8

Joint Installation on New Shaft..... 11



IDA Installation into Vehicle 19

Parts Information:

Part Number	Part Description	Photo	Remarks
498L7-CU000QQH	Shaft Kit, Left Side		1. Shaft 2. Small diameter band (2EA) 3. Large diameter band (2EA) 4. Boot (2EA) 5. Snap ring (2EA) 6. Grease (2EA) 7. Circlip (Only included in right side kit.)
498R7-CU000QQH	Shaft Kit, Right Side		
Left			Shaft Length Left: 20.1in (51.1cm) Right: 21.4in (54.3cm)
Right			

**SUBJECT: REAR INTEGRATED DRIVE AXLE (IDA) SHAFT REPLACEMENT
(RECALL CAMPAIGN 014G)**

Special Service Tools (SST):

Part Number	Part Description	Photo
0K495-C5000	Ear Type Boot Band Installer Tool (for small diameter band)	
09495-G1100	IDA Type [Low Profile] Boot Band Installer Tool (for large diameter band)	

- One of each tool was distributed to each EV certified Genesis Retailer at the start of the recall.
- For retailers that become EV certified after June 12, 2023 or if assistance is needed with these tools, please contact the Genesis Special Service Tools Team at Genesistools@gma.com.

Warranty Information:

Model	Op. Code	Operation	Op. Time	Causal Part	Nature Code	Cause Code
GV60 (JW1)	31D040R2	REAR SHAFT REPLACEMENT (BOTH SIDES)	2.1 M/H	498L7-CU000QQH	Q55	ZZ7

NOTE 1: Submit claim on Claim Entry Screen as “Campaign” type.

NOTE 2: If a part is found in need of replacement while performing this recall and the affected part is still under warranty, submit a separate claim using the same repair order. If the affected part is out of warranty, submit a Prior Approval request for goodwill consideration prior to performing the work.

NOTE 3: Op times include VIN, Mileage and Part (if applicable) validation. **All claims submitted that have incomplete, illegible, or missing documentation are subject to debit.**

NOTE 4: The incident parts are subject to callback through the normal Warranty Technical Center (WTC) parts return process. **Claim is subject to debit if the part is not returned.**

STUI



As outlined in the Digital Documentation Policy, all claims require VIN and Mileage validation through VCI connection or photo capture AND photo capture of the repair Part according to the steps in the TSB. **All claims submitted that have incomplete, illegible, or missing documentation are subject to debit.**

Service Procedure:

Guided Video Information

Refer to the link below for guided video information:

<https://vimeo.com/830705341/2df3ba7a49>

Rear IDA (Integrated Drive Axle) Removal

1. Raise the vehicle and ensure it is securely supported.



Information

When lifting a vehicle using a lift, be careful not to damage the lower parts of the vehicle (floor under cover, battery).
Refer to General Information → Lift and Support Points → General Information in the shop manual.

2. Refer to the shop manual to remove the rear wheels, rear brake calipers, rear brake discs, wheel speed sensors and bracket, and rear under cover.
 - Suspension System → Tires/Wheels → Wheel

i Information

Use the GDS “Brake Pad Change Mode” function to release the parking brake to remove the rear calipers.

Brake System → Brake System → Parking Brake System → Electronic Parking Brake (EPB) → Adjustment

Disconnect the 12v battery negative (-) terminal and the EPB actuator connector after completing the function.

- Brake System → Brake System → Rear Brake Caliper

NOTICE

Do not hang the brake caliper from the brake hose.

- Brake System → Brake System → Rear Disc Brake
- Brake System → ESC → Rear Wheel Speed Sensor
- Motor and Reduction Gear System → Rear Motor and Reduction Gear System → Rear Under Cover

**SUBJECT: REAR INTEGRATED DRIVE AXLE (IDA) SHAFT REPLACEMENT
(RECALL CAMPAIGN 014G)**

3. Separate the rear upper arm front from the rear carrier after removing the bolt and nut (A) on both sides of the vehicle.

Rear Arm to Carrier Tightening Torque

lb-ft	123
N.m	167

NOTICE

- Use a transmission jack to lift the rear carrier to prevent the bolt and nut from damage when removing and installing.
- Ensure the bolts are reinstalled without binding to properly torque the nut.

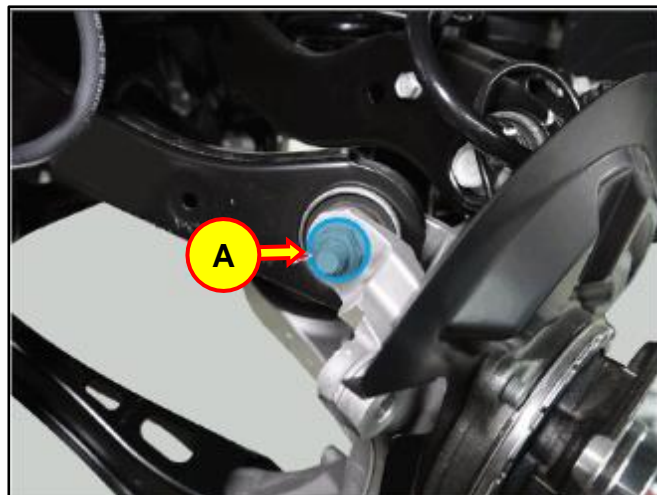

4. Remove the rear carrier mounting bolts (B) on both sides of the vehicle.

Rear Carrier Tightening Torque

lb-ft	148
N.m	173

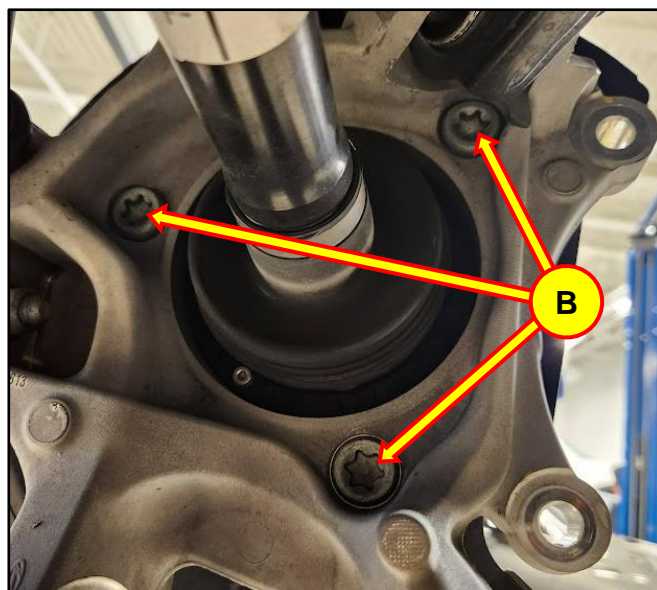

5. Remove both IDAs and place on a work bench.

Left Side IDA

Insert a pry bar between the IDA inner joint cup (C) and the bearing support bracket (D), then carefully pry the joint cup to separate it from the bearing.

Right Side IDA

Insert a pry bar between the IDA inner joint cup (C) and the reduction gear case (E), then carefully pry the joint cup to separate it from the reduction gear.

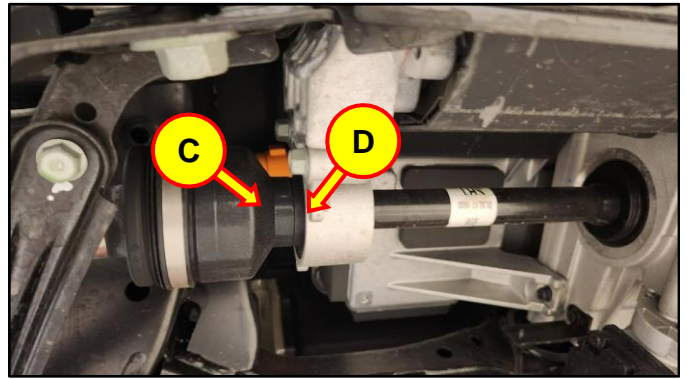

Left Side

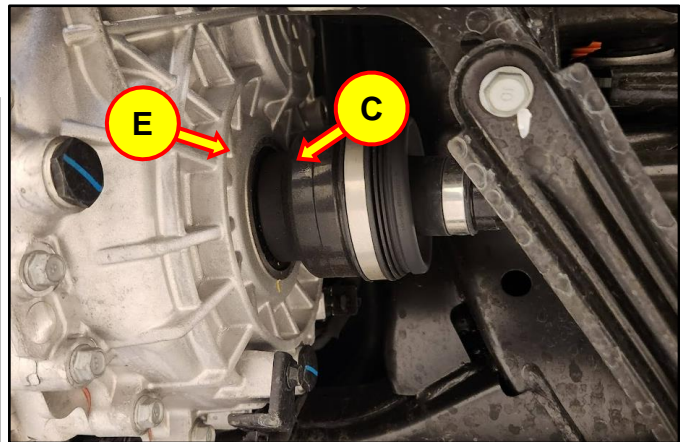

Right Side

NOTICE

- Do not pull the wheel side axle joint (F), or shaft when removing IDA. Damage to the inside of the reduction gear or IDA joint may occur.
- Pull from the inner joint cup (C) to remove it from the bearing or reduction gear case.
- When carrying the IDA, hold the shaft or both joints.
- Do not insert the pry bar too deep, as this may damage the oil seal.
- Do not use excessive force to remove the IDA.
- After removing the IDA, cover the hole of the reduction gear to prevent contamination.
- Remove the circlip (G) on the inner side spline of the right IDA. Use the new circlip provided in the kit during reassembly.

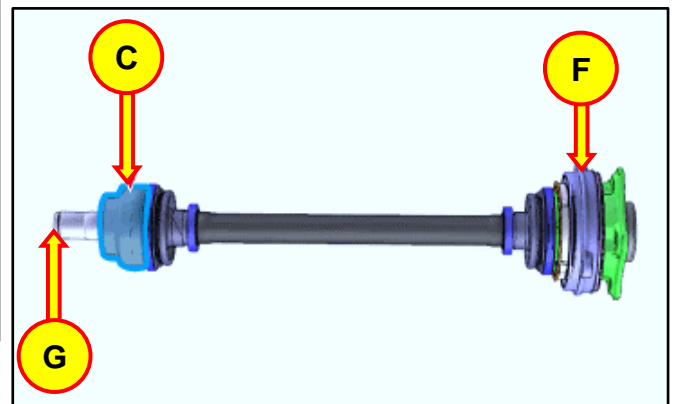

Joint Removal

1. The wheel side (A) and inner side (B) joint cup sub-assemblies will be reused during reassembly of the new axle.

Use the new shaft, boots, bands, snap rings, and circlip supplied in the kit.



2. Starting from either end of the IDA, remove the small and large boot bands by using a flat-blade screwdriver and pry the bands at the locations shown (C), (D), and (E).

i Information

To help pry the bands apart, insert the flat-blade screwdriver into the band as shown and then hit the handle end of the driver with a mallet.

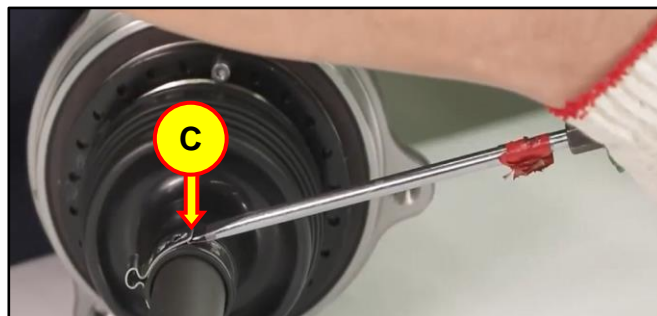

Small Diameter Band

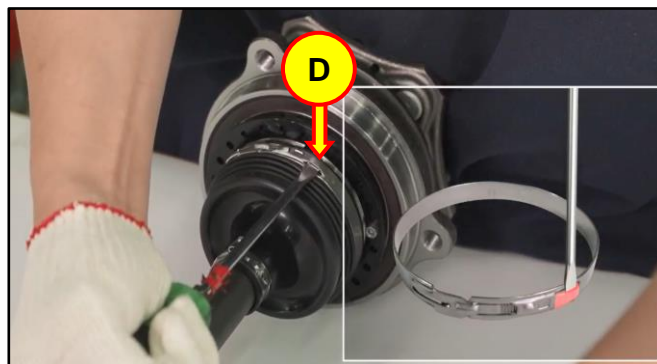

Large Diameter Band



Large Diameter Band

3. Slide the boot off of the joint and down the shaft.
4. Then use a clean cloth to remove as much grease as possible from within the joint to locate and remove the snap ring.
5. Using a rubber mallet, gently tap the joint downward to place the snap ring (F) against the groove.

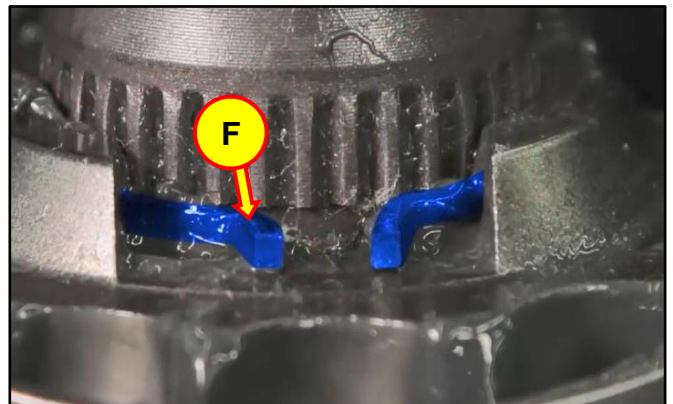
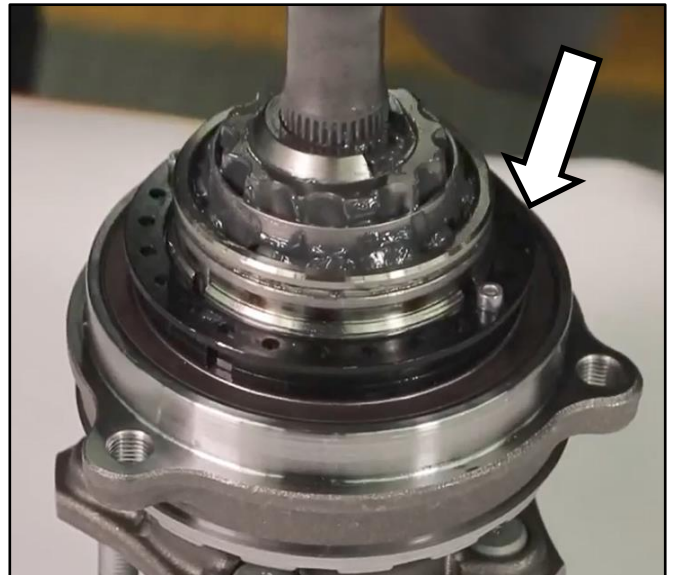
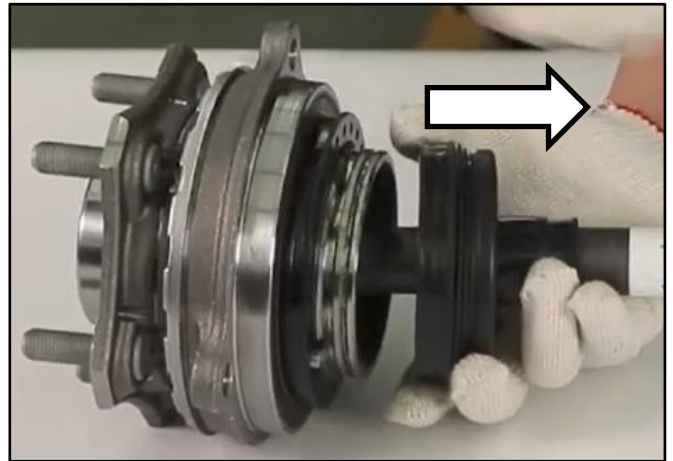

6. Use snap ring pliers to open the snap ring (F). If the snap ring is in position in the groove, the snap ring will stay open. Then pull or gently tap the joint until the shaft (G) is out of the joint.

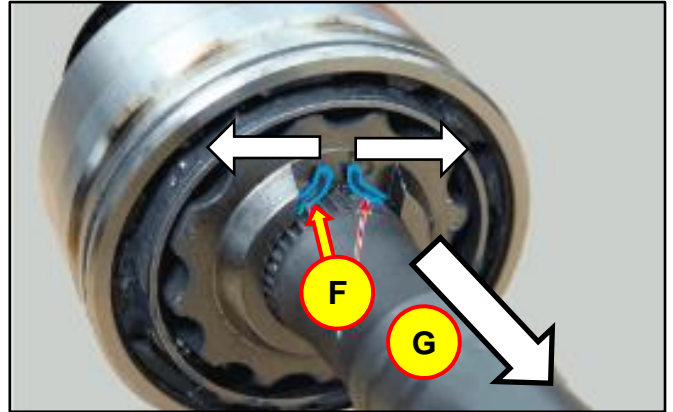

7. Remove the snap ring from within the joint. Do not reuse the snap ring.
8. Set the joint aside in a clean area to reuse on the new axle.
9. Perform steps 2 through 8 to remove the other joint on the other end of the shaft.

Keep the left (driver) and right (passenger) side joints separated to ensure the joints are installed on the correct shaft.

10. Repeat the joint removal procedure on the other IDA shaft.

Joint Installation on New Shaft

1. Do not mix the joints between the left (driver) and right (passenger) side IDA.

**Information****Shaft Length**

Left: 20.1in (51.1cm)

Right: 21.4in (54.3cm)

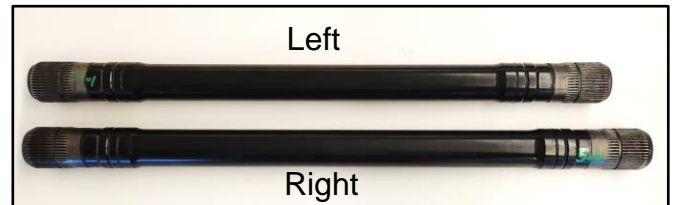

2. Slide the new small and large diameter boot bands (A) on the new shaft.

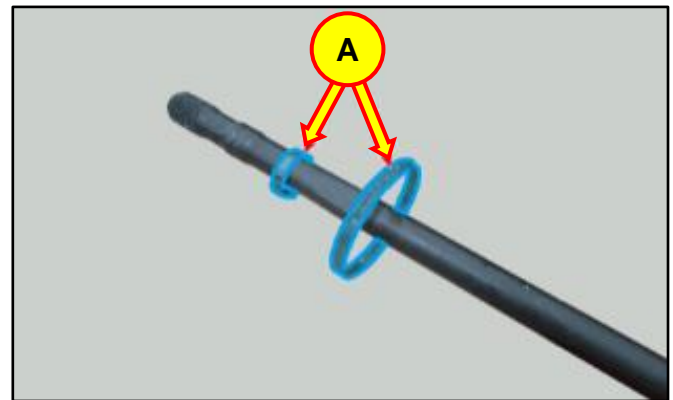

3. Slide a new boot (B) on the shaft.
Keep the interior of the boot clean.



4. Place a new snap ring (C) inside the joint.

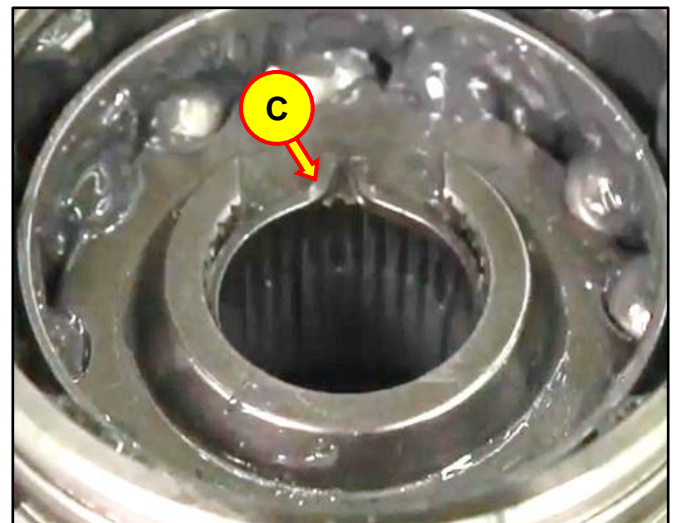

5. Insert the axle splines into the joint until the shaft is secured by the snap ring.

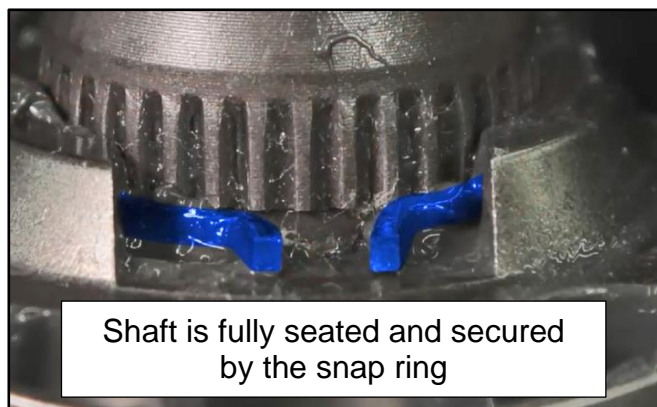

6. Use one grease packet for each joint/boot.

NOTICE

The IDA requires the use of the supplied grease. Do not add or use any other type of grease.

2/3rds for the joint | 1/3rd for the boot



- 7. Apply approximately one-third of the grease inside the boot.



- 8. Apply the remaining two-thirds of the grease in the joint.



- 9. Install the boot onto the joint.



10. Ensure the molded ridge (D) in small end of the boot slides on to the groove that is closest to the spline end (E) when installing the boot onto the joint.

If the boot is installed correctly, the other groove (F) will be visible.

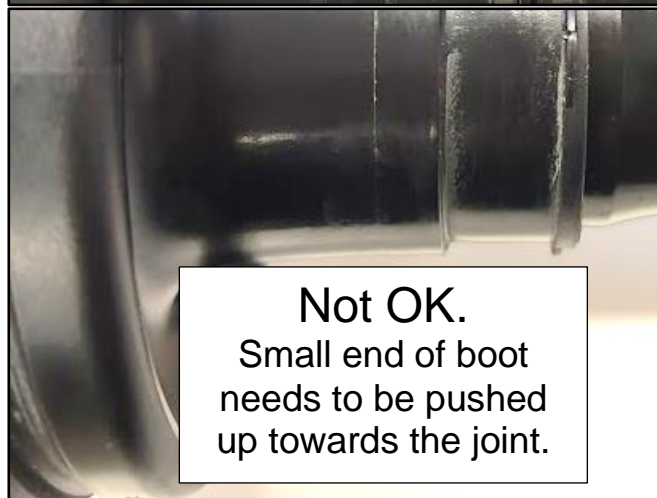
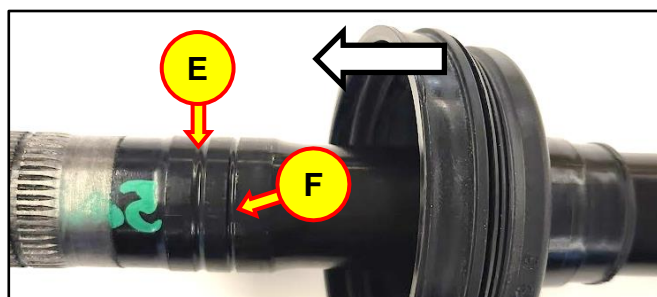

SUBJECT: REAR INTEGRATED DRIVE AXLE (IDA) SHAFT REPLACEMENT (RECALL CAMPAIGN 014G)

- 11. Clean the excess grease from the shaft and boots.
- 12. Place the small and large diameter bands into their respective positions.



- 13. Use the correct tool to clamp each band type.

Small Diameter Band	Larger Diameter Band
<p>Ear type Band Tool (SST: 0K495-C5000)</p>	<p>IDA type (Low profile) Tool (SST: 09495-G1100)</p>

i Information

If it is difficult to open and close the tool smoothly, loosen the three bolts that are circled.

**NOTICE**

- Do not close the tool handles all the way in one motion to clamp the bands on the boot.
- Close the handles slowly and in small increments.
- Check that the bands are clamped to the specifications in steps 14 and 15.
- Over tightening the bands can damage the boot and not provide the proper sealing causing the boots to leak. Conversely, if the bands are under tightened, the boots will leak.



14. Tighten the ears of the small diameter band until it reaches the specified gap (G) of 0.1mm – 2.1mm (0.004in – 0.082in).

Close the handles of the tool slowly and in small increments to reach the specified gap.

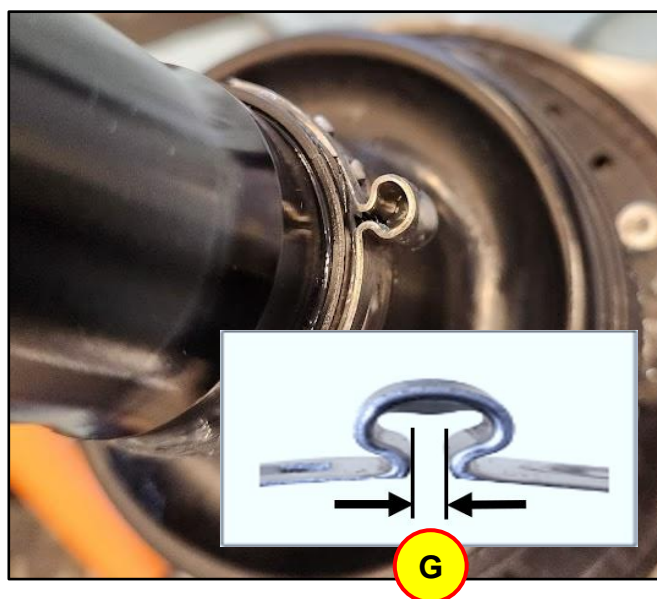

15. Tighten the larger diameter band by hand until only one tooth is visible on the band.

Then use the tool to tighten until the teeth are no longer visible.

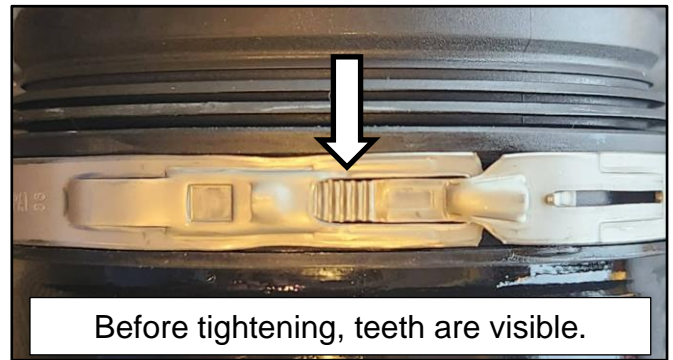

**SUBJECT: REAR INTEGRATED DRIVE AXLE (IDA) SHAFT REPLACEMENT
(RECALL CAMPAIGN 014G)**

16. Repeat the above process to install the other joint to complete the new shaft assembly.
17. Install the joints on the other new shaft following the same procedures above to complete the 2nd new shaft assembly.

18.

STUI



Using STUI, take separate clear photos of the new left (driver) and right (passenger) side assembled IDAs along with the removed shaft, with the shaft's label (H) visible, the last 6 digits of the VIN, IDA side (driver or passenger), and the date of repair on a piece of paper. See examples shown below.

Two photos will be taken, one for the left side and one for the right side.

Upload the photos to STUI.

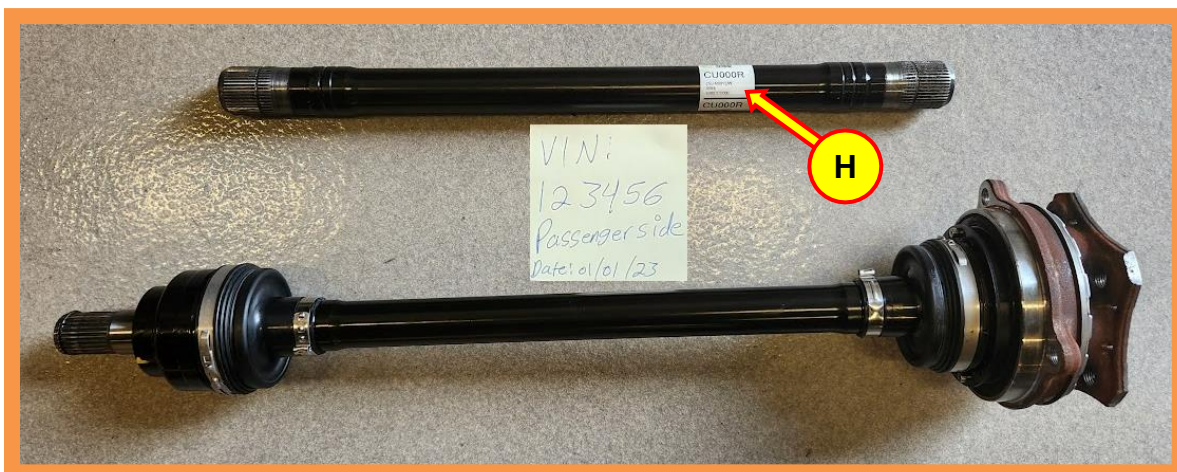

IDA Installation into Vehicle

1. Installation of the newly assembled IDAs is reverse of removal.

**Information**

Install a new circlip (A) to the right side inner spline end before inserting the IDA into the reduction gear.



2. Reinstall other removed parts in the reverse order of removal.
3. The service procedure is now complete.