

SAFETY RECALL – NORTH AMERICA
High Pressure Fuel Pump



Reference: 01A / NHTSA 23V-263

FCA US LLC



Remedy available for
 2021-2023 JL Wrangler and JT Gladiator



Remedy NOT available for
 2022-2023 DT Ram 1500 Pickup

Template Version 1.8

Revision	Edition	Detail
1	October 2023	Revision 1 – Terminology added to “Repair To Be Performed”, Parts Information Updated for clarity.

SUBJECT

The High-Pressure Fuel Pump (HPFP) on about 18,970 of the above vehicles may fail prematurely. A HPFP failure may introduce internally failed component debris into the fuel system potentially causing fuel starvation. Vehicle occupants may notice a Malfunction Indicator Lamp illuminating, a fuel leak, abnormal engine noise, or a change in drive quality. Fuel starvation may result in an unexpected loss of motive power, which can cause vehicle crash without prior warning.

SCOPE

This recall applies only to the above vehicles equipped with a 3.0L engine (sales code EXH or EXJ).

NOTE: Some vehicles above may have been identified as not involved in this recall and therefore have been excluded from this recall.

IMPORTANT: Some of the involved vehicles may be in dealer new vehicle inventory. Federal law requires you to complete this recall service on these vehicles before retail delivery. Dealers should also consider this requirement to apply to used vehicle inventory and should perform this recall on vehicles in for service. Involved vehicles can be determined by using the VIP inquiry process.

REPAIR TO BE PERFORMED

Vehicles delivered to the dealer in good running condition should complete HPFP replacement only (non-contaminated system).

If the vehicle is brought to the dealer not running, the technician will follow the current diagnostic procedure to determine if there was an HPFP failure. If HPFP

failure was determined, replacement of both the HPFP and fuel pump module is required, including fuel system cleaning (contaminated system).

ALTERNATE TRANSPORTATION

Dealers should attempt to minimize customer inconvenience by placing the owner in a loaner vehicle if inspection determines that complete fuel system cleaning and replacement is required, and the vehicle must be held overnight.

COMPLETION REPORTING AND REIMBURSEMENT

Claims for vehicles that have been serviced must be submitted on the DealerCONNECT Claim Entry Screen located on the Service tab. Claims paid will be used by FCA to record recall service completions and provide dealer payments.

Use the following labor operation numbers and time allowances:

Labor Description	Number	Hrs
Replace High Pressure Fuel Pump (JL and JT Only)	14-01-A1-84	1.7
Replace High Pressure Fuel Pump, Fuel Rails, Fuel Lines, Fuel Injectors, Fuel Filter, In Tank Fuel Pump, and Flush Lines (JL and JT Only)	14-01-A1-85	6.6

Labor Description	Number	Allowance
Floor Plan Reimbursement	95-95-95-97	Calculate See Below

Strictly respect STELLANTIS Group safety, cleanliness, and environmental instructions for any intervention. Document exclusively reserved for dealer information. Internal distribution to be ensured by dealer. Reproduction forbidden without the written agreement of STELLANTIS Group. . (djt)

SAFETY RECALL – NORTH AMERICA
High Pressure Fuel Pump



Reference: 01A / NHTSA 23V-263

FCA US LLC

Floor Plan Reimbursement represents the vehicle’s average daily allowance (see table below) multiplied by the number of days the vehicle was in dealer inventory and not available for sale. This reimbursement is limited to the number of days from the date of the stop sale to the date that the remedy was made available. Note: If the vehicle was received by your dealership (KZX date) AFTER the stop sale date, you will use the KZX date instead of the stop sale date. For this Recall, the stop sale was initiated on **04/20/2023** and the remedy was made available on **10/03/2023**, therefore, the number of days cannot exceed **166** days.

Vehicle	Average Daily Allowance
2021-2023 (JL) Jeep Wrangler	██████
2021-2023(JT) Jeep Gladiator	██████

Add the cost of the recall parts package plus applicable dealer allowance to your claim.

In addition, enter “MATL” in the Part Number section of your claim with the applicable Material Allowance where appropriate.

NOTE: See the Warranty Administration Manual, Recall Claim Processing Section, for complete recall claim processing instructions.

PARTS INFORMATION

Part No.	Qty.	Part Name
ORDER THESE PARTS FOR ALL VEHICLES		
CSSMZ461AA	1	HP Fuel Pump (JL/JT/DT) (Contaminated and Non-Contaminated Vehicle)
CSGNZ961AA		HP Fuel Pump Campaign Kit (JL/JT/DT) (Contaminated and Non-Contaminated Vehicle)
	1	EGR Tube (Gasket)
	1	Rubber Gasket - Upper EGR Tube
04275086AE	1	Authorized Modification Label (Contaminated and Non-Contaminated Vehicle)
CSFP01A1AA		SEE ORDERING INFORMATION BELOW THIS TABLE. (Contaminated and Non-Contaminated Vehicle)
	1	Owner’s Manual Addendum
	1	Tip Card
	1	Fuel Door Decal

Process Steps to Order Campaign kit CSFP01A1AA:

1. Access the “**DealerCONNECT**” website.
2. Select the “**Marketing**” link in the header of DealerCONNECT.
3. Locate the “**Product Information**” section heading on the Marketing page.
4. Select the “**Literature and Merchandising Materials**” link in the product information section.
5. Locate the “**MOPAR**” section heading on the Literature and Merchandising Materials page.
6. Select the “**Recall Labels / Cards**” link listed in the MOPAR section.
7. Select **Item > Update Cart > Submit Order**.

SAFETY RECALL – NORTH AMERICA
High Pressure Fuel Pump



Reference: 01A / NHTSA 23V-263

FCA US LLC

ONLY ORDER THESE PARTS FOR NON-CONTAMINATED VEHICLES (NO HPFP FAILURE)		
CSGNZ965AA		HPFP Campaign Kit (JL/JT) (Non - Contaminated vehicles only)
	1	Tube - Fuel Feed to Pump (Pump to Right Rail)
	1	Tube - Fuel Feed to Pump (Pump to Left Rail)
	1	Tube - Fuel Injector Supply

ONLY ORDER THESE PARTS FOR CONTAMINATED VEHICLES (WITH HPFP FAILURE)		
CSGNZ966AA		Fuel Pump & Level Unit (JL/JT) (Contaminated vehicles only)
	1	Fuel Pump and Level Unit (O-Ring)
	1	Fuel Pump/Level Unit (Pkg Part)
68490022AA	6	Fuel Injector (JL/JT/DT) (Contaminated vehicles only)
68148333AA	6	Seal - Fuel Injector (JL/JT/DT) (Contaminated vehicles only)
68148329AB	1	Fuel Rail – Right (JL/JT/DT) (Contaminated vehicles only)
68490028AA	1	Fuel Rail – Left (JL/JT/DT) (Contaminated vehicles only)
68436631AA	1	Filter Kit (Fuel Water Separator) (JL/JT/DT) (Contaminated vehicles only)
68493361AA	1	O-Ring (Upper Turbo Inlet Elbow/EGR Cooler Elbow to LP EGR Valve) (JL/JT/DT) (Contaminated vehicles only)
68487031AA	1	O-Ring (Turbo Upper Air Intake Elbow/EGR Cooler Elbow to Turbo Air Intake Elbow) (JL/JT/DT) (Contaminated vehicles only)
68524869AA	1	TUBE KIT - FUEL SUPPLY (6 Tubes injector to rail, 2 tubes rail to pump, 1 tube rail to rail) (JL/JT) (Contaminated vehicles only)

PARTS RETURN

No parts return required for this campaign.

Strictly respect STELLANTIS Group safety, cleanliness, and environmental instructions for any intervention.
 Document exclusively reserved for dealer information. Internal distribution to be ensured by dealer.
 Reproduction forbidden without the written agreement of STELLANTIS Group.

(DJT)

SAFETY RECALL – NORTH AMERICA
High Pressure Fuel Pump



Reference: 01A / NHTSA 23V-263

FCA US LLC

SPECIAL TOOLS

Number	Description	Picture
NPN	wiTECH MicroPod II/MDP	
NPN	Laptop Computer	
NPN	wiTECH Software	
VM.10345	Tool, High Pressure Pump Installation	
1023	Puller (Originally Shipped In Kit Number(s) 8678)	
APS35IB	Blue Point Spanner Wrench or equivalent	
2025400090	Remover-Installer, Fuel Rail Bolt	
VM.10358A	Remover, Fuel Injector	
9717	Brush, Injector Bore (Originally Shipped In Kit Number(s) 9910)	
8978A	Decay Tool, Fuel	
9340	SAE Fuel Pump Lock Ring Wrench (Originally Shipped In Kit Number(s) 9327, 9327CC, 9397, 9575.	

DEALER NOTIFICATION

To view this notification on DealerCONNECT, select “Global Recall System” on the Service tab, then click on the description of this notification.

OWNER NOTIFICATION AND SERVICE SCHEDULING

All involved vehicle owners known to FCA are being notified of the service requirement by first class mail. They are requested to schedule appointments for this service with their dealers. A generic copy of the owner letter is attached.

SERVICE PROCEDURE

A. JL Vehicles

For vehicles with a contaminated fuel system, use the procedure below.

Remove

VEHICLE LISTS, GLOBAL RECALL SYSTEM, VIP AND DEALER FOLLOW UP

All involved vehicles have been entered into the DealerCONNECT Global Recall System (GRS) and Vehicle Information Plus (VIP) for dealer inquiry as needed.

GRS provides involved dealers with an updated VIN list of their incomplete vehicles. The owner’s name, address and phone number are listed if known. Completed vehicles are removed from GRS within several days of repair claim submission.

To use this system, click on the “**Service**” tab and then click on “**Global Recall System**.” Your dealer’s VIN list for each recall displayed can be sorted by: those vehicles that were unsold at recall launch, those with a phone number, city, zip code, or VIN sequence.

Dealers must perform this repair on all unsold vehicles before retail delivery. Dealers should also use the VIN list to follow up with all owners to schedule appointments for this repair.

Recall VIN lists may contain confidential, restricted owner name and address information that was obtained from the Department of Motor Vehicles of various states. Use of this information is permitted for this recall only and is strictly prohibited from all other use.

ADDITIONAL INFORMATION

If you have any questions or need assistance in completing this action, please contact your Service and Parts District Manager.

Customer Services / Field Operations
 FCA US LLC.

Strictly respect STELLANTIS Group safety, cleanliness, and environmental instructions for any intervention.
 Document exclusively reserved for dealer information. Internal distribution to be ensured by dealer.
 Reproduction forbidden without the written agreement of STELLANTIS Group.

(DIT)

SAFETY RECALL – NORTH AMERICA
High Pressure Fuel Pump



Reference: 01A / NHTSA 23V-263

FCA US LLC

WARNING: High-pressure lines deliver diesel fuel under extreme pressure from the injection pump to the fuel injectors. This may be as high as 2000 bar (29,008 psi). Use extreme caution when inspecting for high-pressure fuel leaks. Fuel under this amount of pressure can penetrate skin causing personal injury or death. Inspect for high-pressure fuel leaks with a sheet of cardboard. Wear safety goggles and adequate protective clothing when servicing fuel system.

WARNING: Observe the following precautions when working on fuel systems: No sparks, open flames or smoking. Avoid inhaling and swallowing fuel. Avoid eye and skin contact with fuel. Pour fuels only into suitable and appropriately marked containers. Wear protective clothing. Failure to observe these precautions may result in fire, explosion, property damage, and serious or fatal injury.

WARNING: High-pressure lines deliver diesel fuel under extreme pressure from the injection pump to the fuel injectors. This may be as high as 2000 bar (29,008 psi). Use extreme caution when inspecting for high-pressure fuel leaks. Fuel under this amount of pressure can penetrate skin causing personal injury or death. Inspect for high-pressure fuel leaks with a sheet of cardboard. Wear safety goggles and adequate protective clothing when servicing fuel system.

WARNING: Observe the following precautions when working on fuel systems: No sparks, open flames or smoking. Risk of poisoning from inhaling and swallowing fuel. Risk of injury to eyes and skin from contact with fuel. Pour fuels only into suitable and appropriately marked containers. Wear protective clothing.

NOTE: When key is cycled to the off position, fuel system pressure automatically bleeds down.

NOTE: The fuel injection pump can be replaced without having to perform the entire base engine valve timing procedure. This procedure gives instruction on how to remove and install the new fuel injection pump without performing the base engine timing. Do not rotate the pump shaft after removing from the vehicle. The alignment of the pump shaft must be measured and recorded using a commercially available degree wheel after the pump is removed and before transferring the pump gear over to the new pump. This is done to align the pump to the same position during installation. If the base engine valve timing must be performed as part of the repair, refer to Service Library 09 - Engine/Valve Timing/Standard Procedure.

Battery Disconnect

1. On this dual battery system the auxiliary battery ground cable connects to the main battery cable end (shown in generic graphic) and grounds through the main battery ground cable connection to the body, chassis or engine (depending on vehicle). Therefore, simply disconnecting and isolating the main battery negative cable clamp from the main battery post will not isolate the auxiliary from the vehicle's electrical system. The auxiliary battery will still be grounded through it's connection to the main battery negative cable end. If both battery negative cables are not isolated it will result in the vehicle electrical system and Power Distribution Center (PDC) still having battery connection which can cause vehicle wiring damage or deployment of air bags on re-connection (Figure 92). In Service Library, see 08 - Electrical / 8F - Engine Systems / Battery System / Standard Procedure / Battery Disconnect - Dual 12 Volt Battery System.

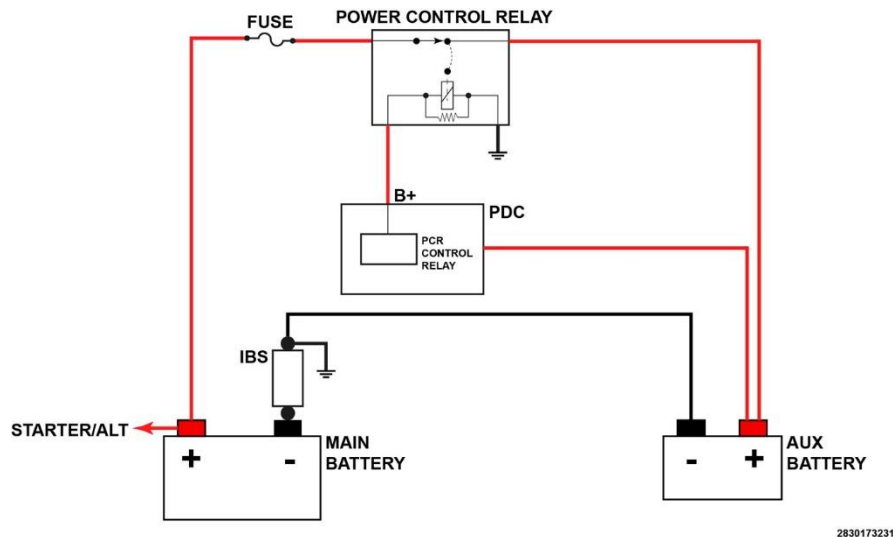

Figure 92 – Dual Battery System

2. Turn the ignition off. Wait five minutes to allow the main modules to go to sleep.
3. Disconnect and isolate the supplemental (auxiliary) battery negative cable from the main battery negative cable end. This will disconnect and isolate the auxiliary battery ground.
4. The main battery ground can be disconnected by removing the main battery negative cable from the negative battery cable end, or by disconnecting the IBS connector, loosening the negative battery clamp nut and removing the negative battery cable end from the battery post. Either method will disconnect the main battery. Both batteries should be disconnected from the vehicle electrical system.
5. Measure the voltage at the PDC positive battery cable connection to verify the vehicle electrical system is powered down.

NOTE: On some vehicles a small amount of voltage may be present (typically less than approximately 0.5 volts) due to capacitors in some modules still having voltage stored. Anything less than 1.0 volts should be safe.

Cooling Fan - Remove

6. Remove the push pins retainers (1) and upper radiator seal (2) (Figure 93).

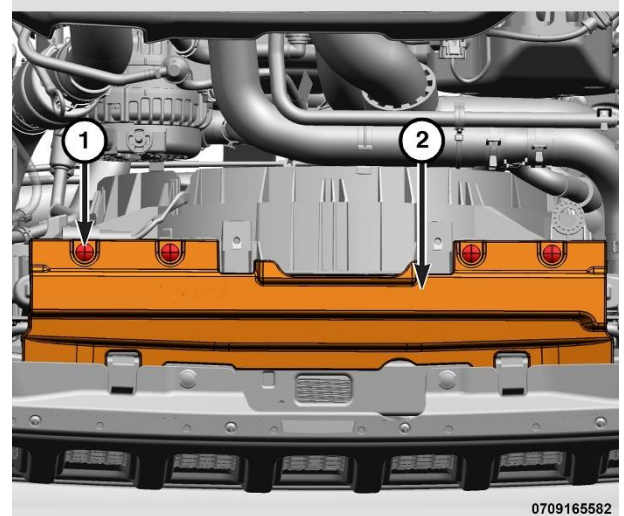

Figure 93 – Upper Radiator Seal

7. Disconnect the cooling fan wire harness connectors (1) and detach the wire harness connector from fan shroud (Figure 94).



Figure 94 – Fan Electrical Connector

SAFETY RECALL – NORTH AMERICA
High Pressure Fuel Pump



Reference: 01A / NHTSA 23V-263

FCA US LLC

8. Remove the left cooling fan bolt (1) (Figure 95).

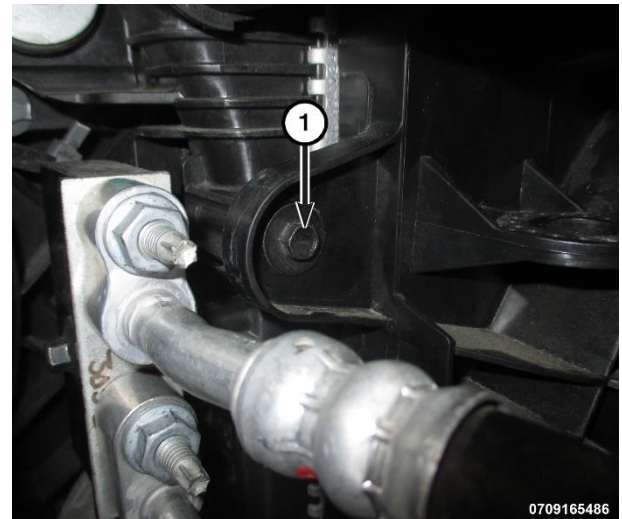

Figure 95 – Left Cooling Fan Bolt

9. Remove the right cooling fan bolt (1) (Figure 96).

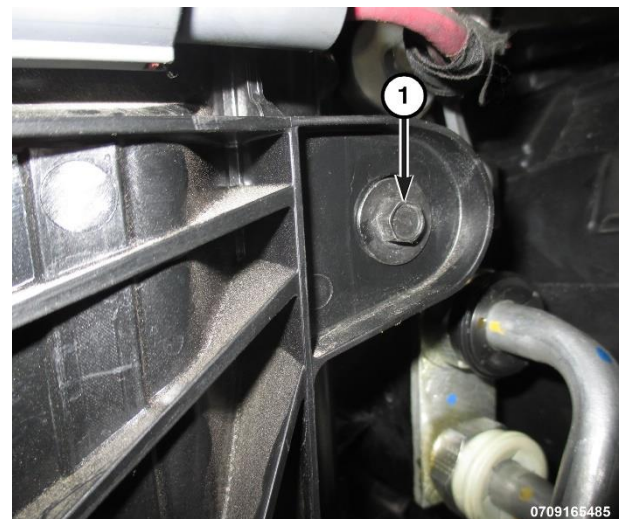

Figure 96 – Right Cooling Fan Bolt

Strictly respect STELLANTIS Group safety, cleanliness, and environmental instructions for any intervention.
Document exclusively reserved for dealer information. Internal distribution to be ensured by dealer.
Reproduction forbidden without the written agreement of STELLANTIS Group.

(DJT)

SAFETY RECALL – NORTH AMERICA
High Pressure Fuel Pump



Reference: 01A / NHTSA 23V-263

FCA US LLC

10. Insert a piece of cardboard between the cooling fan and the radiator.
11. Remove the cooling fan (1) by pulling upwards and away from the radiator (Figure 97).

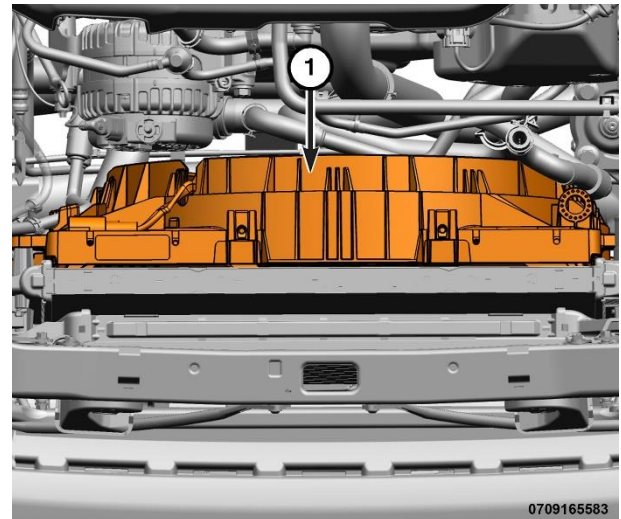

Figure 97 – Cooling Fan

12. Remove the engine cover (Figure 98).



Figure 98 – Engine Cover

PUMP COVER - Remove

13. Remove the clamp at the turbocharger air inlet elbow (1). Slide the CCV hose (2) off at the head. Disconnect the Mass Air Flow electrical connector (3) (Figure 99).
14. Remove the air cleaner body bolt then lift up and the air cleaner body and remove it and the clean air hose as an assembly.

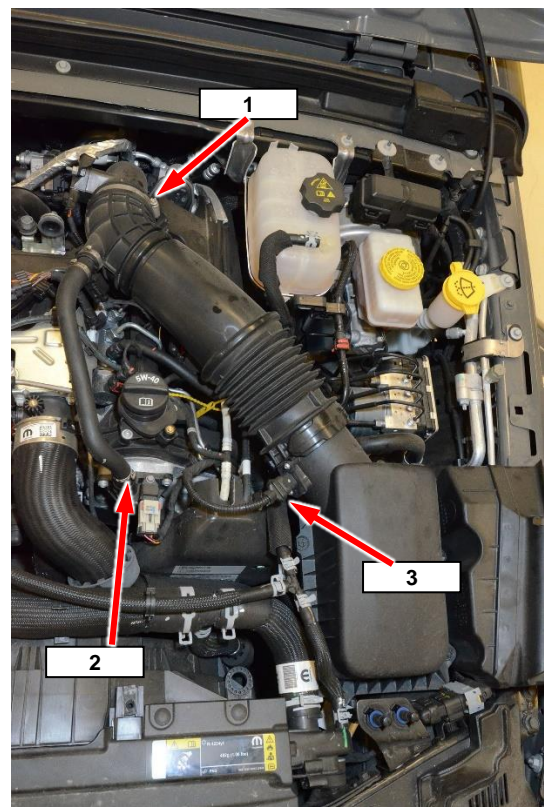

Figure 99 – Inlet Air Tube

SAFETY RECALL – NORTH AMERICA

High Pressure Fuel Pump



Reference: 01A / NHTSA 23V-263

FCA US LLC

15. Release the retaining lock (1) and disconnect the Charge Air Cooler (CAC) hose from the EGR air flow control valve (Figure 100).

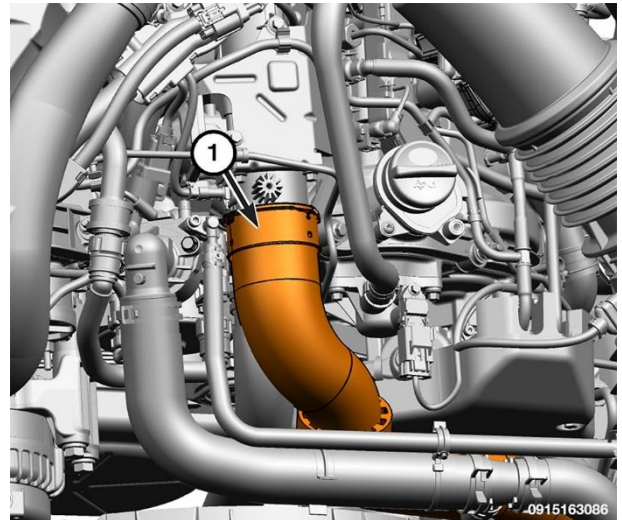

Figure 100 – CAC Hose from EGR Air Flow Control Valve

16. Loosen the left CAC hose clamp and disconnect the left CAC hose from the CAC and remove it (Figure 101).

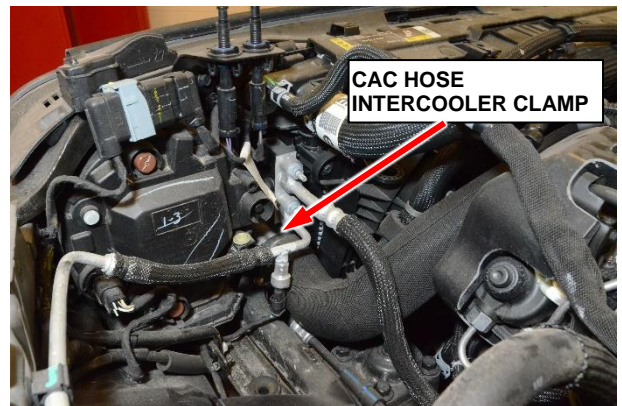

Figure 101 – CAC Hose from Intercooler

Strictly respect STELLANTIS Group safety, cleanliness, and environmental instructions for any intervention.
Document exclusively reserved for dealer information. Internal distribution to be ensured by dealer.
Reproduction forbidden without the written agreement of STELLANTIS Group.

(DJT)

SAFETY RECALL – NORTH AMERICA

High Pressure Fuel Pump



Reference: 01A / NHTSA 23V-263

FCA US LLC

17. Remove the fuel injection pump blocker plate bolts (2) and the fuel injection pump blocker plate (1) from the fuel injection pump (Figure 102).

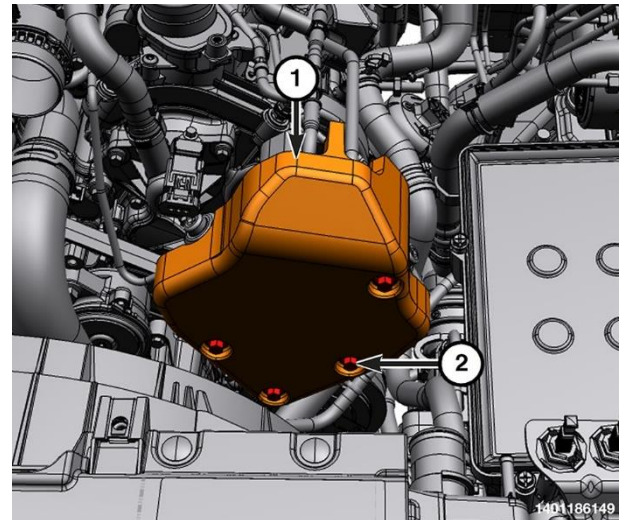

Figure 102 – Blocker Plate

18. Disconnect the low-pressure fuel supply/return lines (4) (Figure 103).
19. Disconnect the fuel quantity solenoid wire harness connector (2) (Figure 103).
20. Remove the fuel rail supply tubes (1 and 3) from the HPFP (Figure 103).

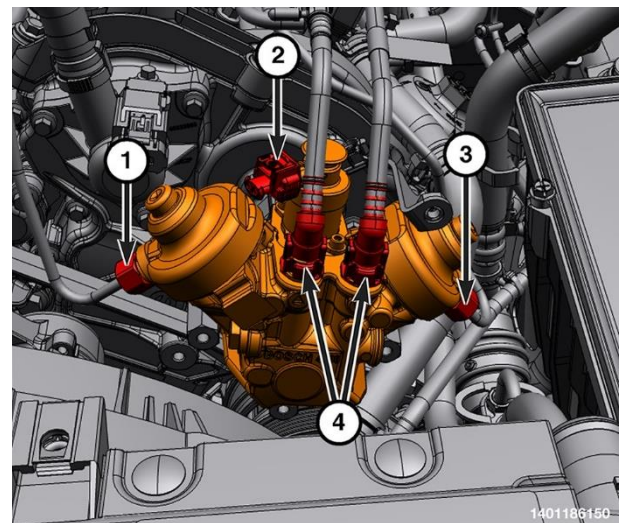

Figure 103 – Fuel Rail Supply Tubes

Strictly respect STELLANTIS Group safety, cleanliness, and environmental instructions for any intervention.
Document exclusively reserved for dealer information. Internal distribution to be ensured by dealer.
Reproduction forbidden without the written agreement of STELLANTIS Group.

(DJT)

RIGHT SIDE - Remove

21. Remove the Charge Air Cooler (CAC) hose bolt (2) (Figure 104).
22. Release the retaining clip (1) and disconnect the CAC hose from the turbocharger elbow and position aside.

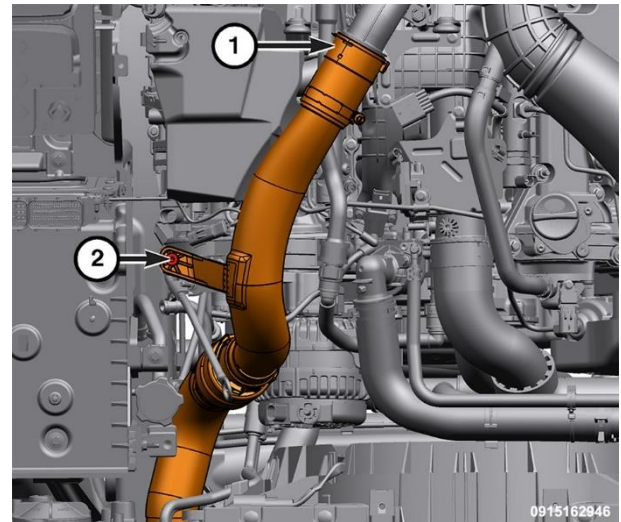

Figure 104 – CAC Hose

23. Loosen the fuel rail cover nut (3), detach the wire harness retainer (1) and remove the fuel rail cover (2) (Figure 105).

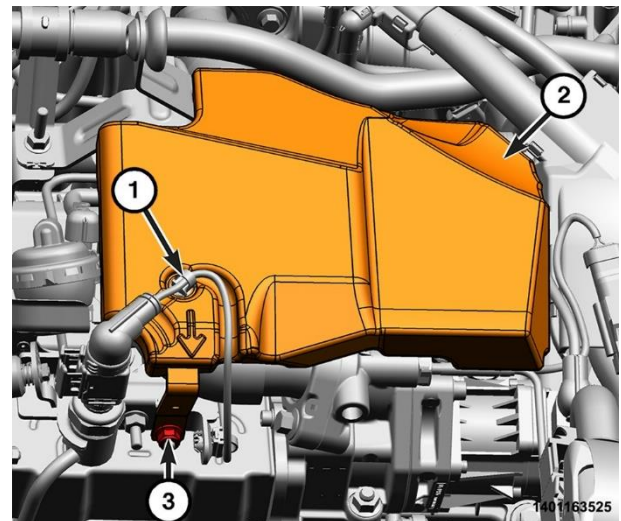

Figure 105 – Fuel Rail Cover

SAFETY RECALL – NORTH AMERICA
High Pressure Fuel Pump



Reference: 01A / NHTSA 23V-263

FCA US LLC

- 24. Remove fasteners from coolant hose support brackets at the front and rear of the engine (Figure 106 and 107).

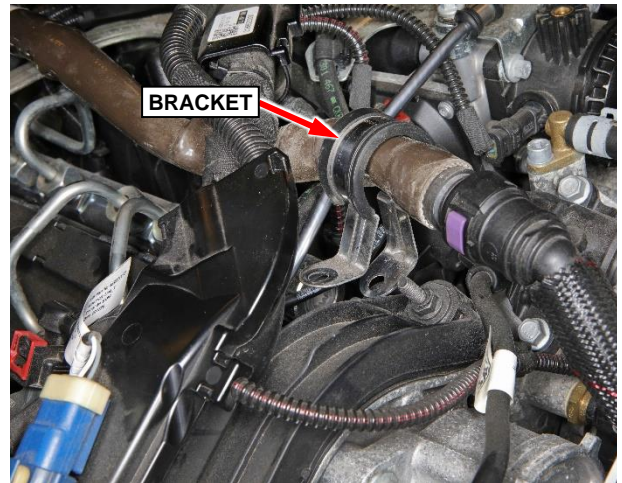

Figure 106 – Front Coolant Hose Bracket

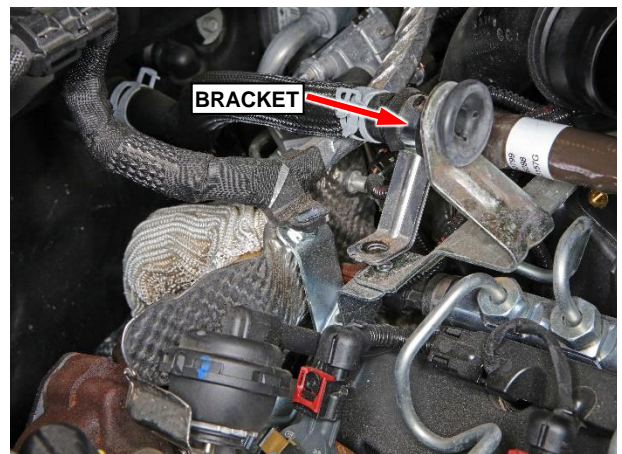

Figure 107 – Rear Coolant Hose Bracket

Strictly respect STELLANTIS Group safety, cleanliness, and environmental instructions for any intervention.
Document exclusively reserved for dealer information. Internal distribution to be ensured by dealer.
Reproduction forbidden without the written agreement of STELLANTIS Group.

(DJT)

SAFETY RECALL – NORTH AMERICA
High Pressure Fuel Pump



Reference: 01A / NHTSA 23V-263

FCA US LLC

- 25. Remove the upper Exhaust Gas Recirculation (EGR) tube bolts (1) (Figure 108).

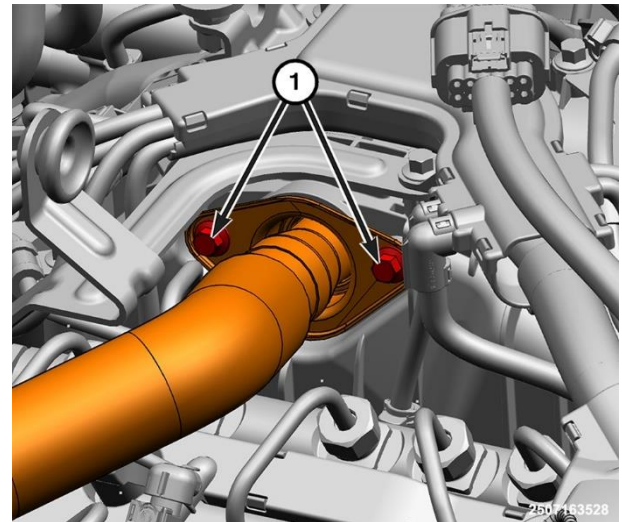

Figure 108 – Upper EGR Tube

- 26. Remove the lower EGR tube bolts (2) and the EGR tube (1) (Figure 109).
- 27. Remove and discard both gaskets.

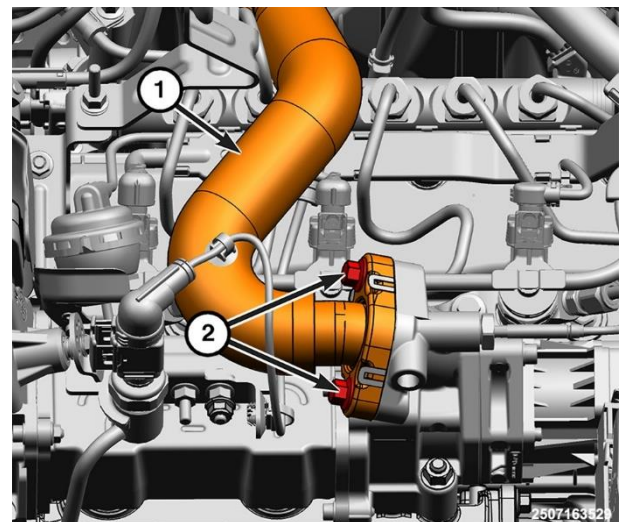

Figure 109 – Lower EGR Tube

Strictly respect STELLANTIS Group safety, cleanliness, and environmental instructions for any intervention.
Document exclusively reserved for dealer information. Internal distribution to be ensured by dealer.
Reproduction forbidden without the written agreement of STELLANTIS Group.

(DJT)

SAFETY RECALL – NORTH AMERICA

High Pressure Fuel Pump



Reference: 01A / NHTSA 23V-263

FCA US LLC

- 28. Lift up on locking tabs (1) to unlock the locks (2) on the right bank fuel return hoses on the tops of the injectors (Figure 110).
- 29. Remove the fuel return hoses (2) by wiggling hoses free from the fuel injector (Figure 110).

NOTE: Use a backing wrench on the fuel injector when unscrewing the union nut.

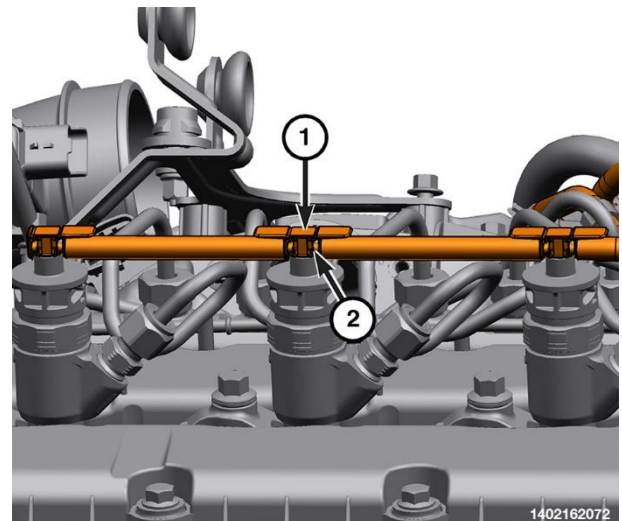

Figure 110 – Fuel Return Hoses

- 30. Unscrew the union nuts (7 and 9) and remove cylinder No. 1 fuel tube (8) and the discard fuel tube (Figure 111).
- 31. Unscrew the union nuts (4 and 6) and remove cylinder No. 2 fuel tube (5) and discard the fuel tube (Figure 111).
- 32. Unscrew the union nuts (1 and 3) and remove cylinder No. 3 fuel tube (2) and discard the fuel tube (Figure 111).

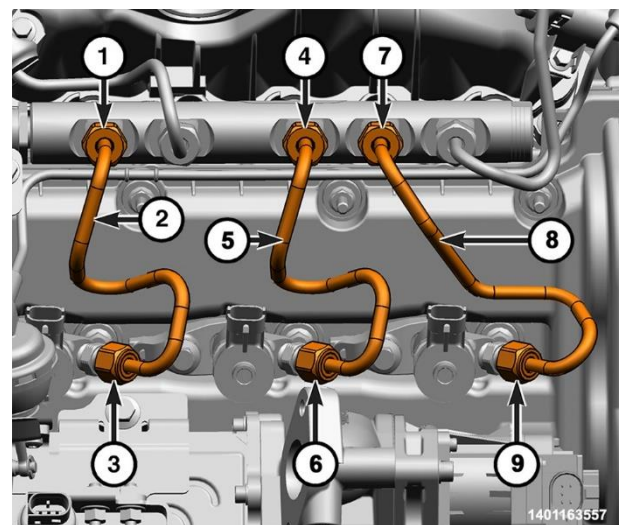

Figure 111 – Right Fuel Injector Tubes

Strictly respect STELLANTIS Group safety, cleanliness, and environmental instructions for any intervention.
Document exclusively reserved for dealer information. Internal distribution to be ensured by dealer.
Reproduction forbidden without the written agreement of STELLANTIS Group.

(DJT)

SAFETY RECALL – NORTH AMERICA

High Pressure Fuel Pump



Reference: 01A / NHTSA 23V-263

FCA US LLC

LEFT SIDE - Remove

33. Remove the vent hose (1) from the left fuel rail cover (Figure 112).

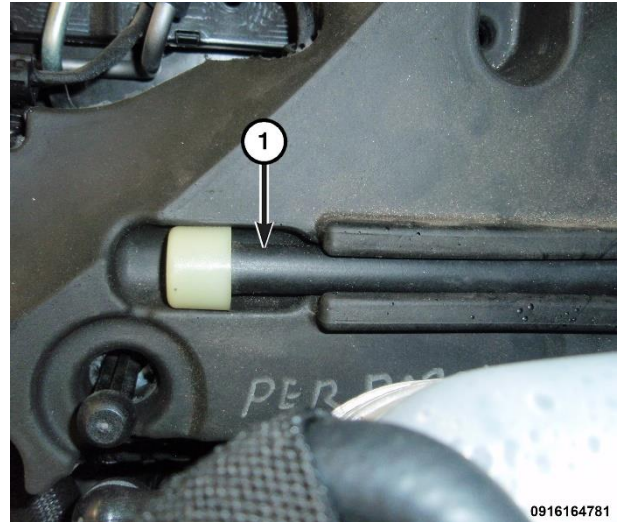

Figure 112 – Vent Hose

34. Remove the left fuel rail cover bolts (1) and the left fuel rail cover (2) (Figure 113).

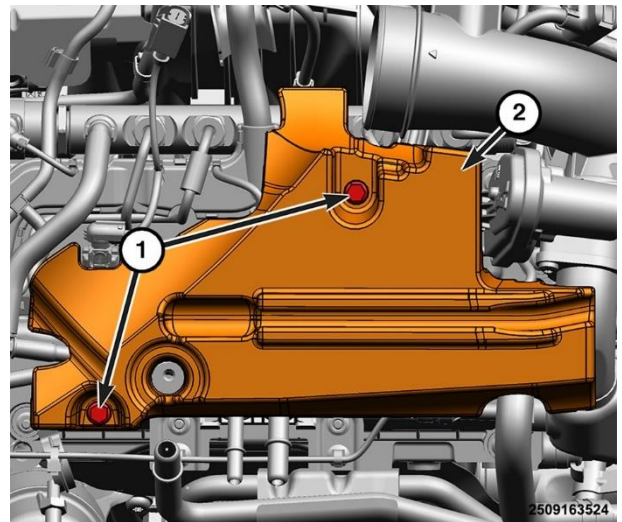

Figure 113– Fuel Rail Cover

Strictly respect STELLANTIS Group safety, cleanliness, and environmental instructions for any intervention.
Document exclusively reserved for dealer information. Internal distribution to be ensured by dealer.
Reproduction forbidden without the written agreement of STELLANTIS Group.

(DJT)

SAFETY RECALL – NORTH AMERICA

High Pressure Fuel Pump



Reference: 01A / NHTSA 23V-263

FCA US LLC

35. Lift up on locking tabs (1) to unlock the locks on the fuel return hoses on the tops of the injectors (Figure 114).
36. Disconnect the fuel return lines by wiggling the hoses free from the fuel injectors (Figure 114).

NOTE: Use a backing wrench on the fuel injector when unscrewing the union nut.

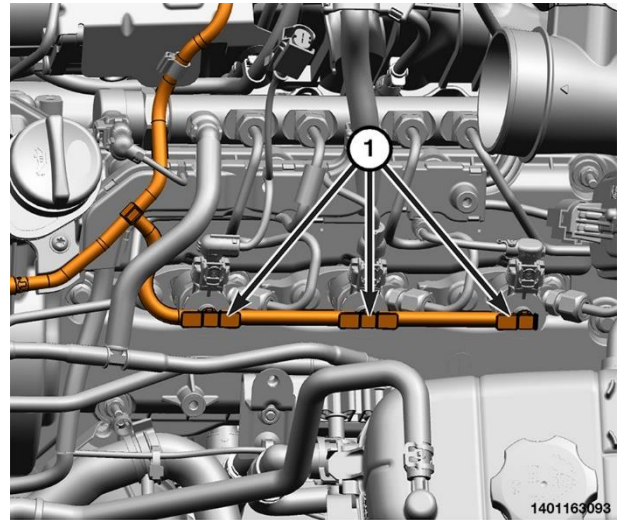

Figure 114 – Fuel Return Hoses

37. Unscrew the union nuts (1 and 3) and remove cylinder No. 4 fuel tube (2) and discard the fuel tube (Figure 115).
38. Unscrew the union nuts (4 and 6) and remove cylinder No. 5 fuel tube (5) and discard the fuel tube (Figure 115).
39. Unscrew the union nuts (7 and 9) and remove cylinder No. 6 tube (8) and discard the fuel tube (Figure 115).

Crossover Tube - Remove

40. Detach the vacuum line from the coolant bottle bracket.
41. Remove the coolant bottle bolts and position aside the coolant bottle.
42. Detach the brake booster vacuum hose from the bracket.

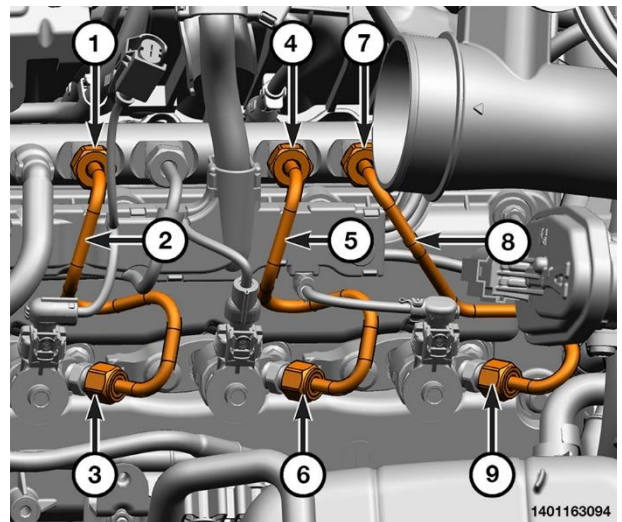

Figure 115 – Fuel Injector Tubes

SAFETY RECALL – NORTH AMERICA
High Pressure Fuel Pump



Reference: 01A / NHTSA 23V-263

FCA US LLC

- 43. Disconnect the differential pressure sensor wire harness connector (1) (Figure 116).

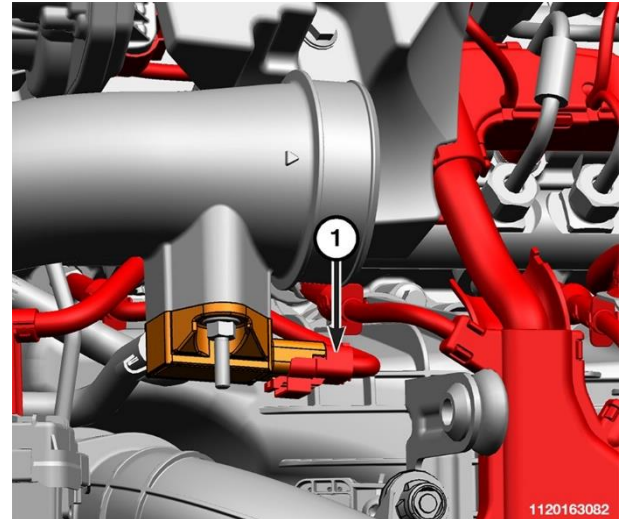

Figure 116 – Pressure Sensor Connector

- 44. Disconnect the differential pressure sensor hoses (1) (Figure 117).
- 45. Remove the differential pressure sensor nut (3) and the differential pressure sensor (2) (Figure 117).

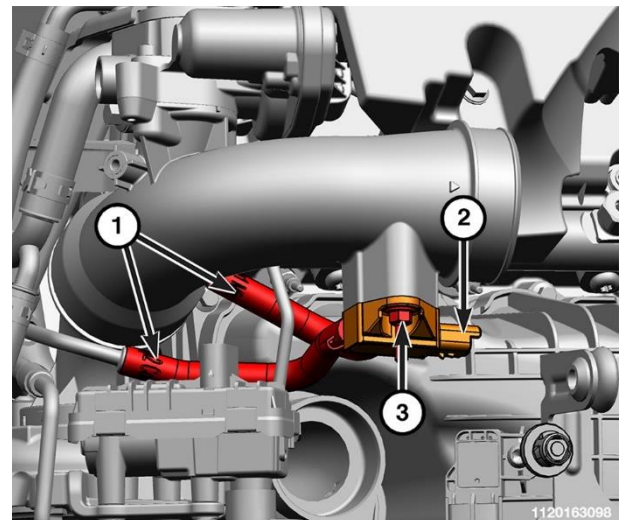

Figure 117 – Differential Pressure Sensor

Strictly respect STELLANTIS Group safety, cleanliness, and environmental instructions for any intervention.
Document exclusively reserved for dealer information. Internal distribution to be ensured by dealer.
Reproduction forbidden without the written agreement of STELLANTIS Group.

(DJT)

SAFETY RECALL – NORTH AMERICA

High Pressure Fuel Pump



Reference: 01A / NHTSA 23V-263

FCA US LLC

- 46. Remove the low pressure EGR valve to the upper turbocharger inlet elbow bolts and remove the upper turbocharger inlet elbow (Figure 118).
- 47. Remove and DISCARD the low pressure EGR valve gasket (1) (Figure 118).

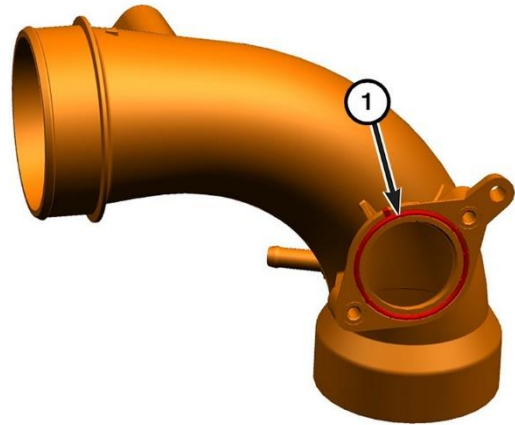

2507162264

Figure 118 – Upper Turbo Inlet Elbow Gasket

- 48. Remove and DISCARD the lower turbocharger inlet elbow gasket (1) (Figure 119).
- 49. Disconnect the boost pressure sensor wire harness connector.
- 50. Disconnect the swirl valve wire harness connector.
- 51. Disconnect the fuel pressure sensor wire harness connector.

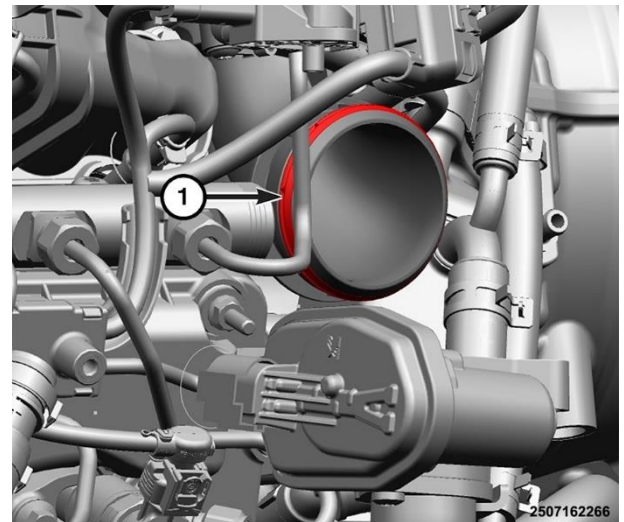

2507162266

Figure 119 – Lower Turbo Inlet Elbow Gasket

SAFETY RECALL – NORTH AMERICA
High Pressure Fuel Pump



Reference: 01A / NHTSA 23V-263

FCA US LLC

- 52. Remove the fuel crossover tube bolt (1) (Figure 120).

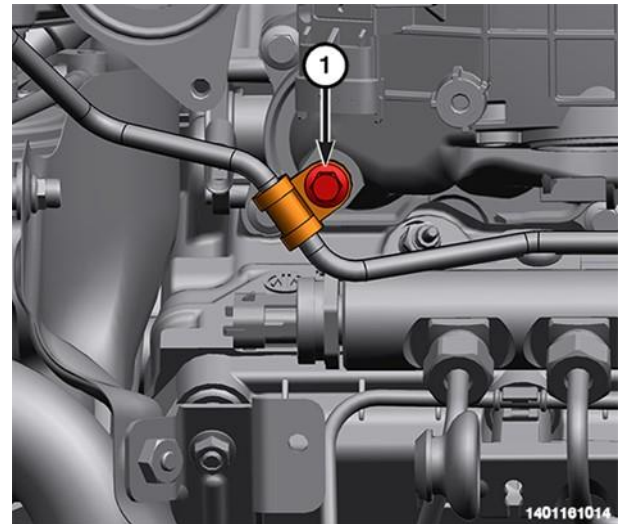

Figure 120 – Crossover Tube Bolt

- 53. Unscrew the union nuts (1 and 3) and remove the fuel crossover tube (2) and discard (Figure 121).

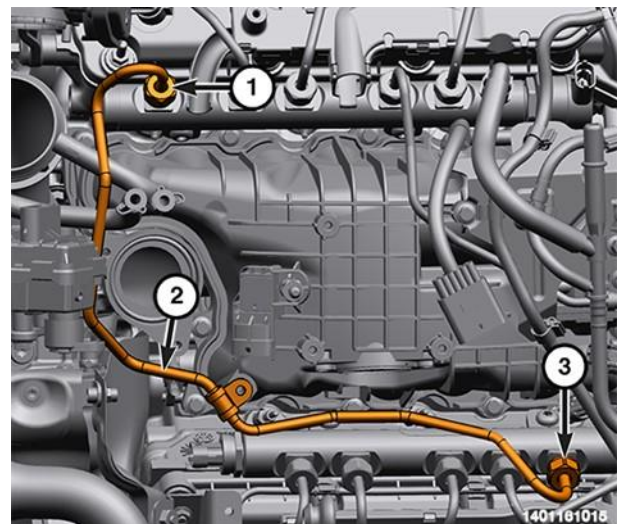

Figure 121 – Crossover Tube Bolt

Strictly respect STELLANTIS Group safety, cleanliness, and environmental instructions for any intervention.
Document exclusively reserved for dealer information. Internal distribution to be ensured by dealer.
Reproduction forbidden without the written agreement of STELLANTIS Group.

(DJT)

SAFETY RECALL – NORTH AMERICA

High Pressure Fuel Pump



Reference: 01A / NHTSA 23V-263

FCA US LLC

Left Fuel Rail Supply Tube - Remove

54. Remove the left fuel tube bracket nut (1) securing the fuel tube (Figure 122).
55. Unscrew the union nut (2) from the fuel rail and remove and discard the fuel tube (Figure 122).

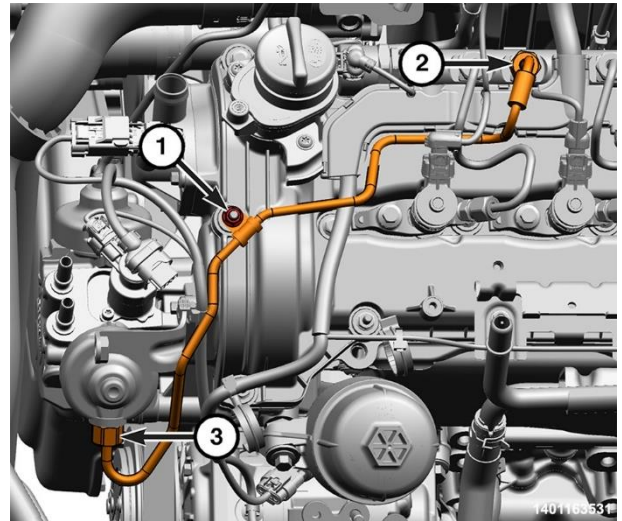

Figure 122 – Left High Pressure Fuel Tube Nut

Right Fuel Rail Supply Tube - Remove

56. Release the retaining clip (1) and disconnect the CAC hose from the EGR air flow control valve (Figure 123).

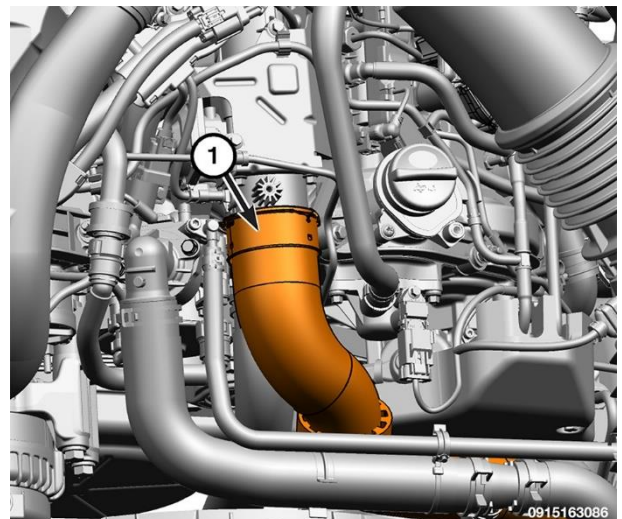

Figure 123 – CAC Hose Clip

Strictly respect STELLANTIS Group safety, cleanliness, and environmental instructions for any intervention.
Document exclusively reserved for dealer information. Internal distribution to be ensured by dealer.
Reproduction forbidden without the written agreement of STELLANTIS Group.

(DJT)

SAFETY RECALL – NORTH AMERICA

High Pressure Fuel Pump



Reference: 01A / NHTSA 23V-263

FCA US LLC

57. Remove the fuel tube bolt (2) securing the fuel tube (Figure 124).
58. Unscrew the union nut (1) and remove and discard the fuel tube (Figure 124).
59. Install protective caps over the openings.

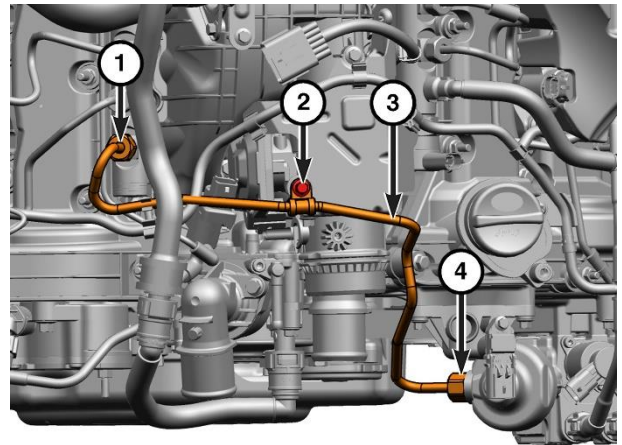

1401164943

Figure 124 – Right High-Pressure Fuel Tube Bolt

Fuel Injector Return Lines - Remove

60. Lift up on locking tabs at each injector to unlock the locks (1 and 3) (Figure 125).
61. Remove the fuel return lines by wiggling hose free from the fuel injectors (Figure 125).
62. Remove the fuel return line retainers (2) and detach the fuel injector return line from the main fuel return line (4) (Figure 125).

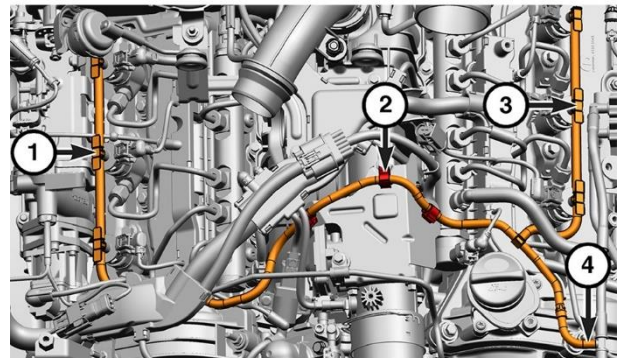

1401163083

Figure 125 – Injector Return Lines

Strictly respect STELLANTIS Group safety, cleanliness, and environmental instructions for any intervention.
Document exclusively reserved for dealer information. Internal distribution to be ensured by dealer.
Reproduction forbidden without the written agreement of STELLANTIS Group.

(DJT)

SAFETY RECALL – NORTH AMERICA

High Pressure Fuel Pump



Reference: 01A / NHTSA 23V-263

FCA US LLC

- 63. Detach the fuel return line retainers (1 and 2) (Figure 126).
- 64. Remove the fuel injector return line assembly (3) (Figure 126).

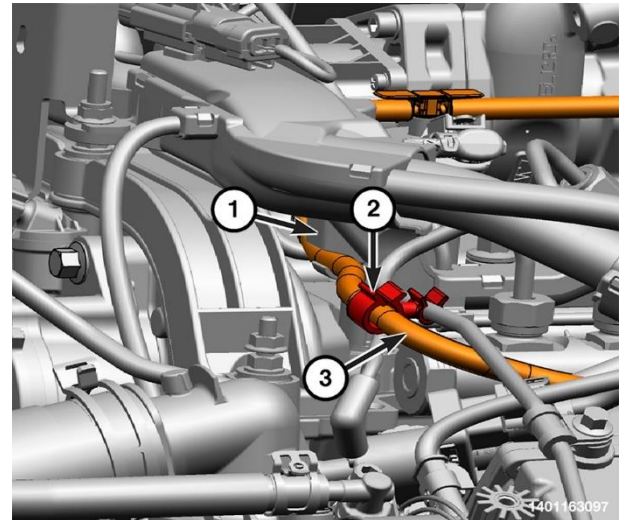

Figure 126 – Injector Return Line Retainers

Fuel Injector Rails - Remove

- 65. Disconnect the fuel pressure regulator wire harness connector (1) on the LEFT rail (Figure 127).

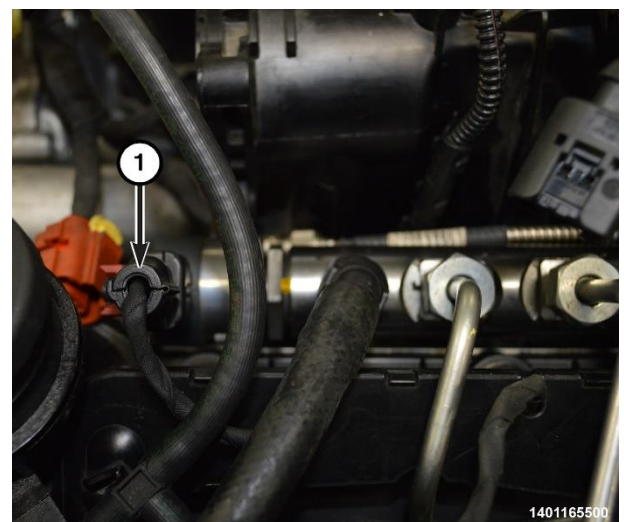

Figure 127 – Fuel Pressure Regulator Connector (Left Rail)

Strictly respect STELLANTIS Group safety, cleanliness, and environmental instructions for any intervention.
Document exclusively reserved for dealer information. Internal distribution to be ensured by dealer.
Reproduction forbidden without the written agreement of STELLANTIS Group.

(DJT)

SAFETY RECALL – NORTH AMERICA
High Pressure Fuel Pump



Reference: 01A / NHTSA 23V-263

FCA US LLC

66. Using the Remover-Installer, Fuel Rail Bolt 2025400090, remove the left fuel rail bolts (2) and the left fuel rail (1) (Figure 128).

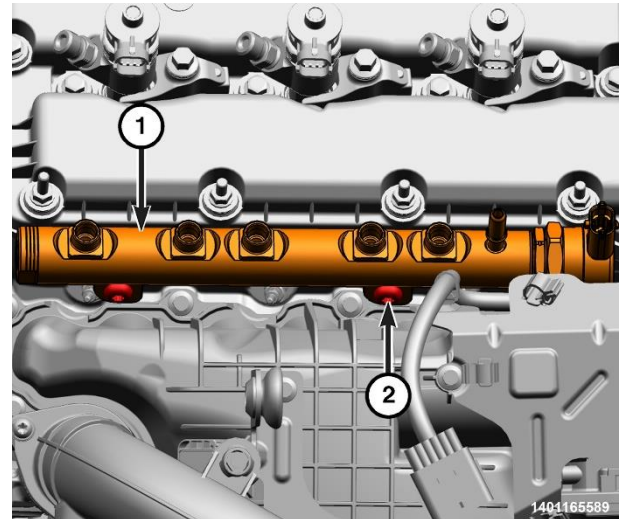
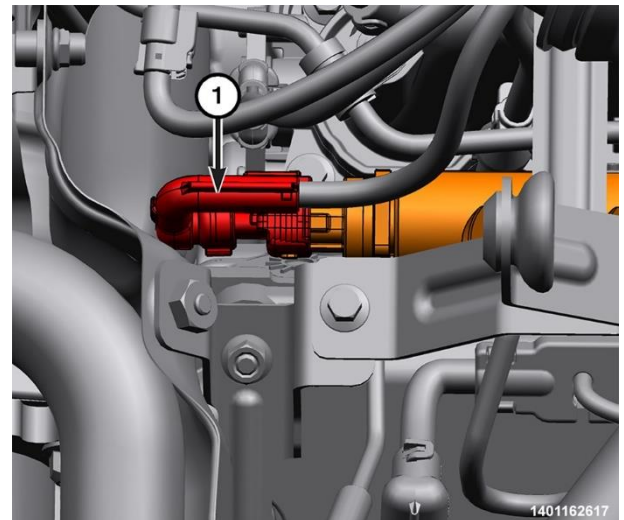

Figure 128 – Left Fuel Rail

67. Disconnect the fuel pressure sensor harness connector (1) on the RIGHT rail (Figure 129).



**Figure 129 – Fuel Pressure Sensor
Right Fuel Rail**

SAFETY RECALL – NORTH AMERICA

High Pressure Fuel Pump



Reference: 01A / NHTSA 23V-263

FCA US LLC

- 68. Using the Remover-Installer, Fuel Rail Bolt 2025400090, remove the right fuel rail bolts (2) and the right fuel rail (1) (Figure 130).

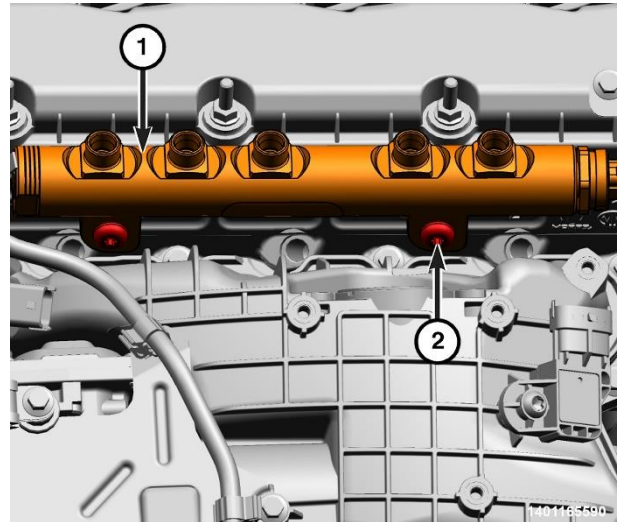

Figure 130 – Right Fuel Rail

Fuel Injectors - Remove

- 69. Disconnect the fuel injector wire harness connectors (1) (Figure 131).
- 70. Clean the area around the fuel injectors so that no debris falls into the injector bores.

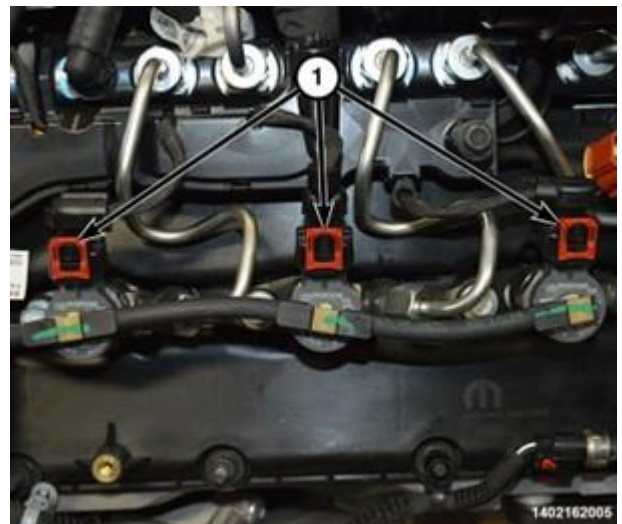

Figure 131 – Fuel Injector Wire Harness Connectors

Strictly respect STELLANTIS Group safety, cleanliness, and environmental instructions for any intervention.
Document exclusively reserved for dealer information. Internal distribution to be ensured by dealer.
Reproduction forbidden without the written agreement of STELLANTIS Group.

(DJT)

SAFETY RECALL – NORTH AMERICA
High Pressure Fuel Pump



Reference: 01A / NHTSA 23V-263

FCA US LLC

- 71. Remove the fuel injector clamp bolts (1) and the fuel injector clamps (2) (Figure 132).

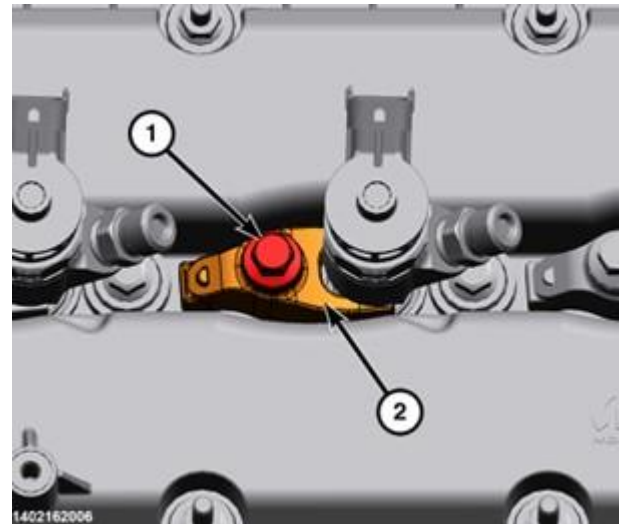

Figure 132 – Fuel Injector Clamps

- 72. Using your hand, pull the fuel injectors (1) straight up from the cylinder head for removal. Discard the lower sealing washer and place a protective cap over the injector bore (Figure 133).

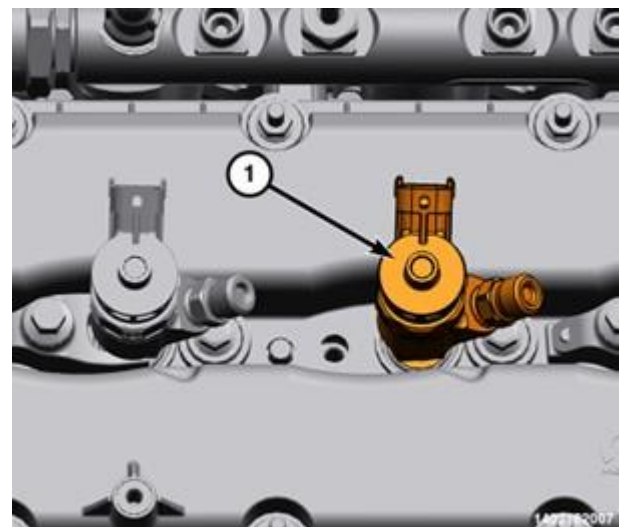

Figure 133 – Fuel Injectors

Strictly respect STELLANTIS Group safety, cleanliness, and environmental instructions for any intervention.
Document exclusively reserved for dealer information. Internal distribution to be ensured by dealer.
Reproduction forbidden without the written agreement of STELLANTIS Group.

(DJT)

SAFETY RECALL – NORTH AMERICA

High Pressure Fuel Pump



Reference: 01A / NHTSA 23V-263

FCA US LLC

73. If an injector can't be removed by hand, install the Remover, Fuel Injector VM.10358A (1) to remove the fuel injector. Discard lower sealing washer and place a protective cap over the injector bore (Figure 134).

NOTE: Check and **MAKE SURE** that the copper sealing washer did not remain in the cylinder head.

NOTE: Steps 74 - 75 necessary for fuel injector No. 3.



Figure 134 – Remover, Fuel Injector VM.10358A

74. Disconnect the EGR cooler vacuum bypass hose (1) (Figure 135).

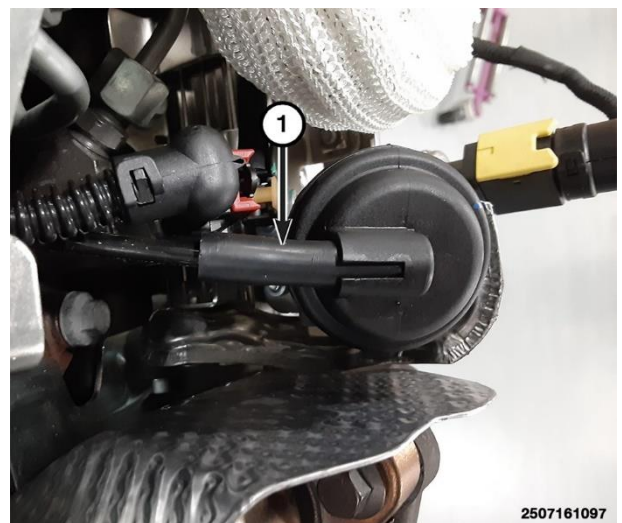

Figure 135 – EGR Cooler Vacuum Bypass Hose

75. Remove the vacuum actuator with heat shield screws (1) and position aside the vacuum actuator (Figure 136).

NOTE: When a NEW fuel injector is being installed, or if an existing injector is installed in any location other than its original location, the injector quantity adjustment procedure must be performed (Refer to 14 - Fuel System/Fuel Injection - Standard Procedure).

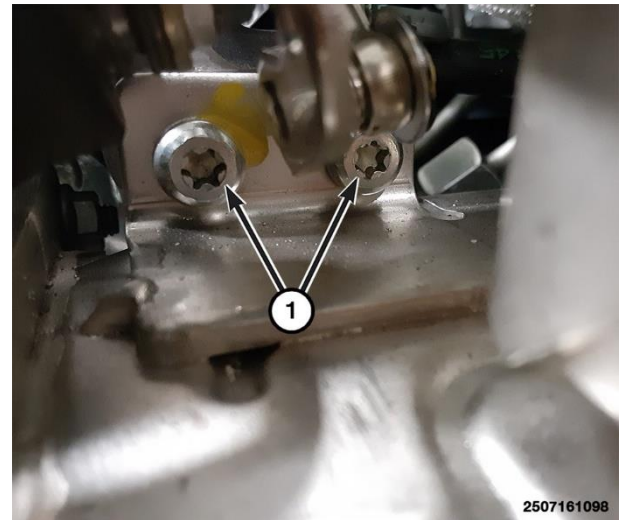

Figure 136 – Vacuum Actuator Screws

HIGH PRESSURE FUEL PUMP – Remove and Replace

NOTE: The fuel injection pump can be replaced without having to perform the entire base engine valve timing procedure. Do not rotate the pump shaft after removing from the vehicle. The alignment of the pump shaft must be measured and recorded using a commercially available degree wheel after the pump is removed and before transferring the pump gear over to the new pump. This is done to align the pump to the same position during installation. If the base engine valve timing must be performed as part of the repair (Refer to 09 - Engine/Valve Timing/Standard Procedure).

SAFETY RECALL – NORTH AMERICA

High Pressure Fuel Pump



Reference: 01A / NHTSA 23V-263

FCA US LLC

- 76. Remove the upper bolts (1) from the high-pressure pump (Figure 137).
- 77. Using Tool, High Pressure Pump Installation VM.10345 Install the studs in the upper locations.

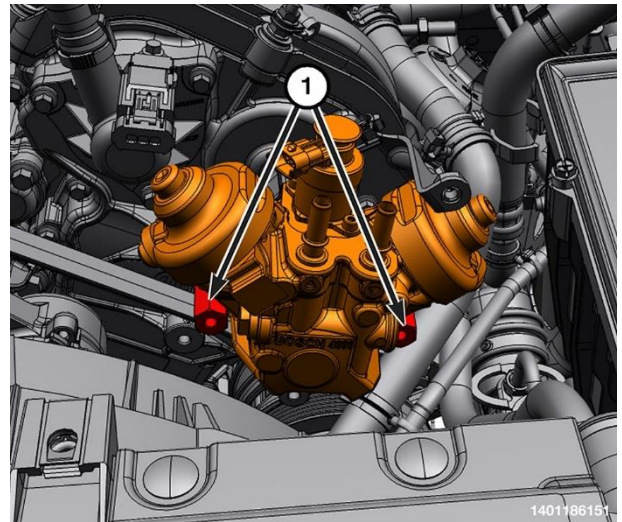

Figure 137 – HPFP Upper Bolts

- 78. Remove the lower bolt (1) from the HPFP (2) and remove it from the vehicle (Figure 138).

NOTE: The fuel injection pump needs to be timed using a commercially available degree wheel.

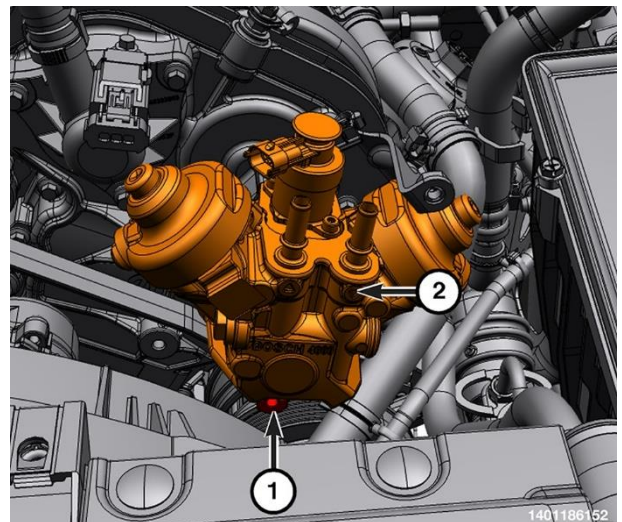

Figure 138 – HPFP Lower Bolt

Strictly respect STELLANTIS Group safety, cleanliness, and environmental instructions for any intervention.
Document exclusively reserved for dealer information. Internal distribution to be ensured by dealer.
Reproduction forbidden without the written agreement of STELLANTIS Group.

(DJT)

SAFETY RECALL – NORTH AMERICA

High Pressure Fuel Pump



Reference: 01A / NHTSA 23V-263

FCA US LLC

- 79. Install the degree wheel onto the pump and record the position of the hole in the gear on the degree wheel (Figure 139).
- 80. The use of Puller 1023 or a commercially available gear puller is required to remove the fuel injection pump gear (Figure 140).



Figure 139 – Degree Wheel

NOTE: The use of Puller 1023 or a commercially available gear puller is required to remove the fuel injection pump gear (2) (Figure 142).

CAUTION: Do Not Force the high-pressure pump into the right timing cover or attempt to seat it by drawing it in with the bolts. The pump gear must be properly aligned with the drive gear on the camshaft before the high-pressure pump will seat on the cylinder head mounting surface. Failure to properly align drive gears will damage the high-pressure pump or camshaft drive gear.

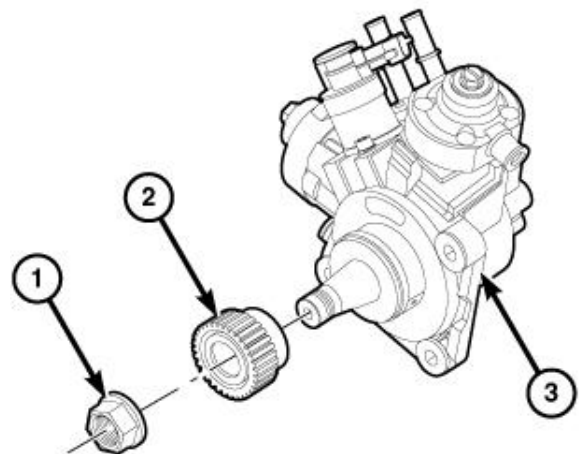

3361085

Figure140 – Gear Removal

Strictly respect STELLANTIS Group safety, cleanliness, and environmental instructions for any intervention.
Document exclusively reserved for dealer information. Internal distribution to be ensured by dealer.
Reproduction forbidden without the written agreement of STELLANTIS Group.

(DT)

SAFETY RECALL – NORTH AMERICA
High Pressure Fuel Pump



Reference: 01A / NHTSA 23V-263

FCA US LLC

- 81. Install a **NEW** O-ring seal (1) to the fuel injection pump (Figure 141).

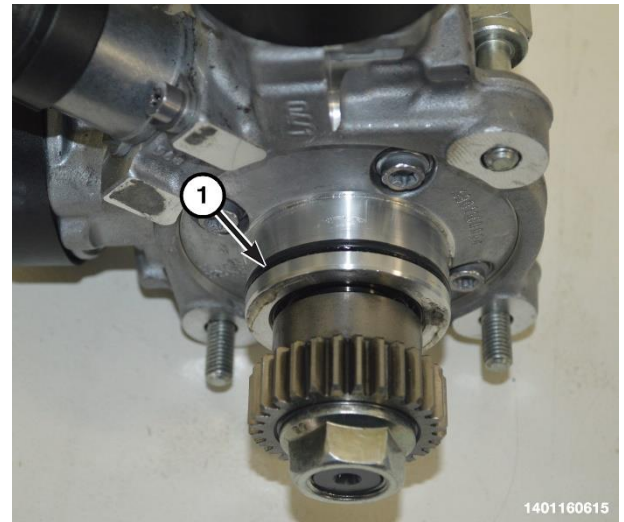

Figure 141 – O-ring Seal

- 82. Install the gear (2) and nut (1) onto the fuel injection pump (3) and tighten the nut (1) finger tight (Figure 142).

Note: NEVER use an impact to tighten the gear nut.

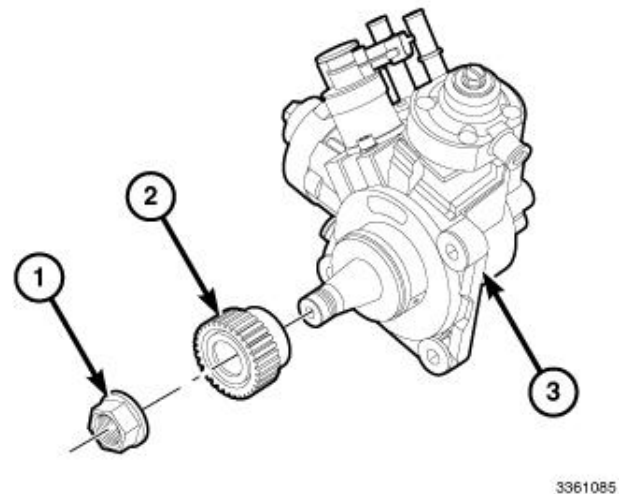

Figure 142 – Gear and Nut

SAFETY RECALL – NORTH AMERICA

High Pressure Fuel Pump



Reference: 01A / NHTSA 23V-263

FCA US LLC

- 83. Using a commercially available spanner wrench (2) such as Blue Point APS35IB or equivalent, tighten the nut (1) to 50 N·m (37 ft. lbs.) (Figure 143).

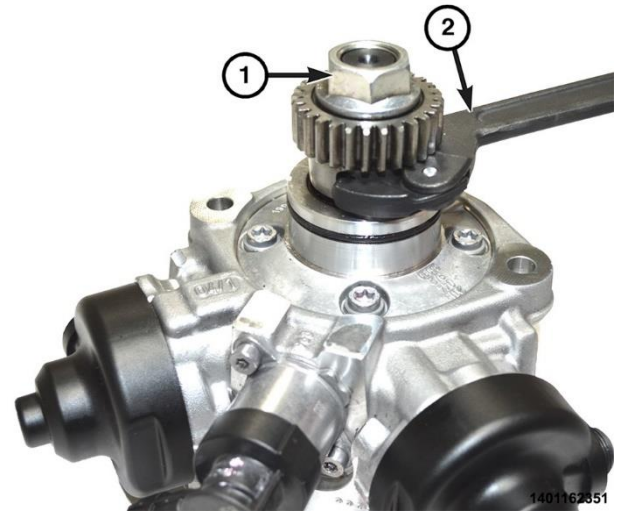

Figure 143 – Nut with Spanner Wrench

- 84. Install the degree wheel and rotate the pump shaft so that the hole aligns with the reference mark on the degree wheel referenced during the removal (Figure 144).
- 85. Install the fuel injection pump onto the Tool, High Pressure Pump Installation VM.10345 in the upper timing cover.
- 86. Install the lower fuel injection pump bolt (2) and hand tighten the bolt (1) (Figure 138).
- 87. Remove the Tool, High Pressure Pump Installation VM.10345 from the upper bolts location and install the bolts.
- 88. Tighten the bolts (1) that secure the fuel injection pump to 25 N·m (18 ft. lbs.) (Figures 138 and 137).



Figure 144 – Degree Wheel

Strictly respect STELLANTIS Group safety, cleanliness, and environmental instructions for any intervention.
Document exclusively reserved for dealer information. Internal distribution to be ensured by dealer.
Reproduction forbidden without the written agreement of STELLANTIS Group.

(DJT)

SAFETY RECALL – NORTH AMERICA
High Pressure Fuel Pump



Reference: 01A / NHTSA 23V-263

FCA US LLC

89. Remove the protective cap from the appropriate injector bore.

NOTE: Make sure the old copper sealing washer is not stuck in bore.

90. Clean the fuel injector bore (Refer to 09 - Engine/Fuel Injection/INJECTORS, Fuel/Cleaning).

91. Install a **NEW** fuel injector seal (1) in the cylinder head cover (Figure 145).

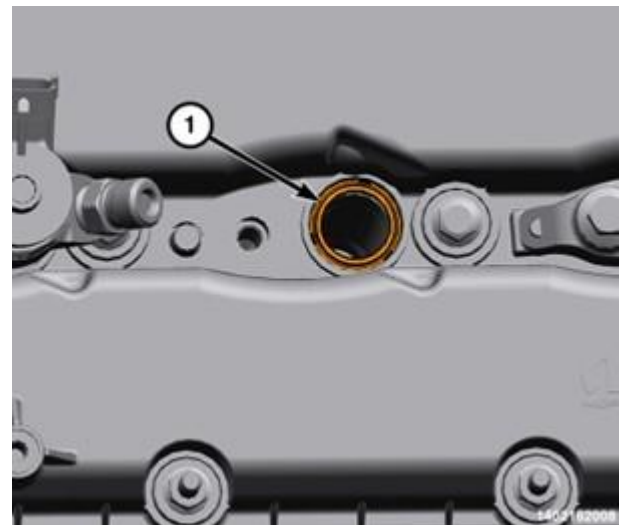

Figure 145 – Upper Sealing Washer

SAFETY RECALL – NORTH AMERICA
High Pressure Fuel Pump



Reference: 01A / NHTSA 23V-263

FCA US LLC

- 92. Install a **NEW** sealing washer (2) onto the fuel injector (1) (Figure 146).

NOTE: Do Not apply any lubricant to the fuel injector nozzle. Care must be taken not to restrict the discharge orifices in the nozzle.

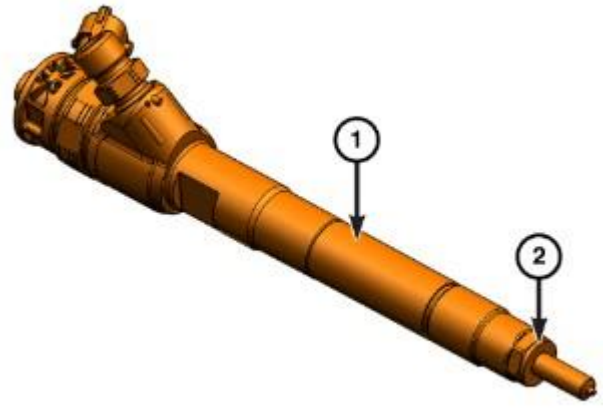

1402162016

Figure 146 – Lower Sealing Washer

- 93. Lubricate the **NEW** injector body with Nickel Anti-Seize Lubricant (Figure 147).



Figure 147 – Lubricate the Fuel Injector

SAFETY RECALL – NORTH AMERICA
High Pressure Fuel Pump



Reference: 01A / NHTSA 23V-263

FCA US LLC

- 94. Install the fuel injector (1) in the cylinder head (Figure 148).

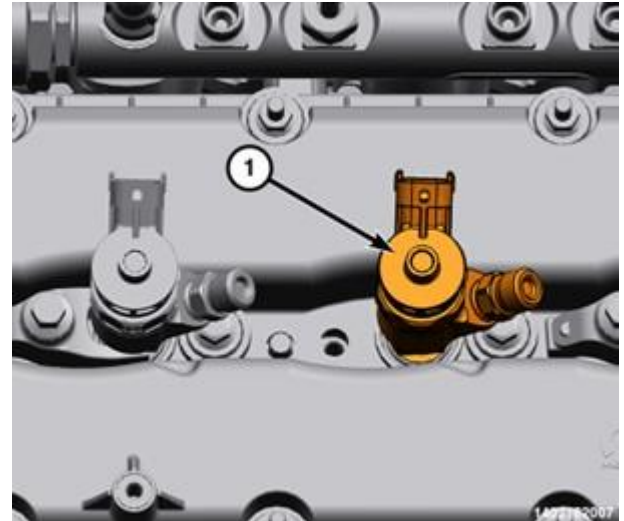

Figure 148 – Fuel Injector

- 95. Install the fuel injector clamp (2) and tighten the bolt (1) to 33 N·m (24 ft. lbs.). Repeat for all injectors (Figure 149).

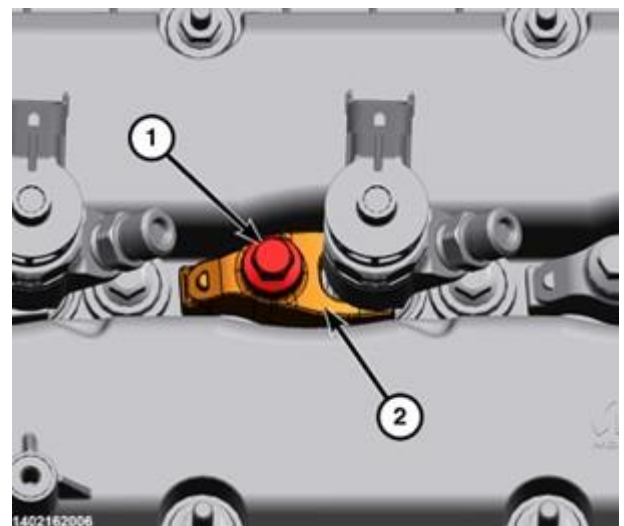

Figure 149– Fuel Injector Bolt and Clamp

Strictly respect STELLANTIS Group safety, cleanliness, and environmental instructions for any intervention.
Document exclusively reserved for dealer information. Internal distribution to be ensured by dealer.
Reproduction forbidden without the written agreement of STELLANTIS Group.

(DJT)

96. Install the **NEW** fuel rails. Using the Remover-Installer, Fuel Rail Bolt 2025400090 tighten the bolts to 25 N·m (18 ft. lbs.).
97. Connect the fuel pressure sensor harness connector on the RIGHT rail (Figure 129).
98. Install the vacuum actuator with heat shield screws (1) (Figure 136).
99. Install the EGR cooler vacuum bypass hose (1) (Figure 135).
100. Install the fuel injector wire harness connectors (1) (Figure 131).
101. Install the fuel pressure regulator wire harness connector on the LEFT rail (Figure 127).
102. Install low-pressure fuel return line to the hard lines and to the return side of the pump. Leave the fuel supply side disconnected from the pump at this time.
103. Connect the fuel quantity solenoid wire harness connector (2) (Figure 103).
104. Install a **NEW** fuel crossover tube (2) and tighten the union nuts (1, 3) to 11 N·m + 75° (8 ft. lbs. + 75°) (Figure 121).
105. Install the fuel crossover tube bolt (1) and tighten securely (Figure 120).
106. Connect the fuel pressure sensor wire harness connector.
107. Connect the swirl valve wire harness connector.
108. Connect the boost pressure sensor wire harness connector.
109. Install a **NEW** lower turbocharger inlet elbow gasket (Figure 119).
110. Install a **NEW** low pressure EGR valve gasket (Figure 118).
111. Install the upper turbocharger inlet elbow and the low pressure EGR valve to the upper turbocharger inlet elbow bolts and tighten to 11 N·m (8 ft. lbs.) (Figure 118).
112. Install the differential pressure sensor and securely tighten the differential pressure sensor nut (Figure 117).
113. Connect the differential pressure sensor hoses (1) (Figure 117).
114. Connect the differential pressure sensor wire harness connector (1) (Figure 116).
115. Attach the brake booster vacuum hose from the bracket.
116. Install the coolant bottle, bracket, and nuts, and tighten the nuts to 10 N·m (89 In. Lbs.).
117. Attach the vacuum line to the coolant bottle bracket.

NOTE: The fuel tubes are a one-time only use and must be replaced anytime they have been removed.

NOTE: Use a backing wrench on the fuel injector when tightening the union nut.

118. Install the **NEW** fuel rail supply tubes (1 and 3) at the HPFP and rails. Tighten both ends to 11 N·m + 75° (8 ft. lbs. + 75°) (Figures 103, 122 and 124).

119. Connect the CAC hose from the EGR air flow control valve and secure the retaining clip (1) (Figure 123).

120. Install the fuel tube bracket bolts and securely tighten.

121. Install the **NEW** right side fuel tubes (Figure 111):

- Remove the protective caps from cylinder No. 3 fuel injector and fuel rail.
- Install the **NEW** fuel tube to cylinder No. 3 and tighten the union nuts finger tight.
- Remove the protective caps from cylinder No. 2 fuel injector and fuel rail.
- Install the **NEW** fuel tube to cylinder No. 2 and tighten the union nuts finger tight.
- Remove the protective caps from cylinder No. 1 fuel injector and fuel rail.
- Install the **NEW** fuel tube to cylinder No. 1 and tighten the union nuts finger tight.
- Tighten the fuel rail union nuts to 11 N·m + 75° (8 ft. lbs. + 75°).
- Tighten the fuel injector union nuts to 11 N·m + 75° (8 ft. lbs. + 75°).

122. Install the **NEW** left side fuel tubes (Figure 115):

- Remove the protective caps from cylinder No. 6 fuel injector and fuel rail.
- Install the **NEW** fuel tube to cylinder No. 6 and tighten the union nuts finger tight.
- Remove the protective caps from cylinder No. 5 fuel injector and fuel rail.
- Install the **NEW** fuel tube to cylinder No. 5 and tighten the union nuts finger tight.
- Remove the protective caps from cylinder No. 4 fuel injector and fuel rail.
- Install the **NEW** fuel tube to cylinder No. 4 and tighten the union nuts finger tight.
- Tighten the fuel rail union nuts to 11 N·m + 75° (8 ft. lbs. + 75°).
- Tighten the fuel injector union nuts to 11 N·m + 75° (8 ft. lbs. + 75°).

NOTE: Do not use any type of lubrication when installing the fuel injector return hose.

123. Install the fuel injector return hose assembly. Install the fuel injector return hose and be sure it is fully seated. Push down on the lock tab to lock in place (Figures 125 and 126).

124. Install the left fuel rail cover (2) and the left fuel rail cover bolt (1) and tighten securely (Figure 113).

125. Install the vent hose (1) to the left fuel rail cover (Figure 112).

126. Install the lower EGR tube (1) and the EGR tube bolts (2) and tighten to 25 N·m (18 Ft. Lbs.) (Figure 109).

127. Install the upper Exhaust Gas Recirculation (EGR) tube bolts (1) and tighten to 11 N·m (8 Ft. Lbs.) (Figure 108).
128. Install fasteners to coolant hose support brackets at the front and rear of the engine and tighten securely (Figure 106 and 107).
129. Install the fuel rail cover (2), attach the wire harness retainer (1), and securely tighten the right fuel rail cover nut (3) (Figure 105).
130. Connect the CAC hose to the turbocharger elbow and fasten the retaining clip (Figure 104).
131. Install the Charge Air Cooler (CAC) hose bolt (2) and tighten to 11 N·m (8 Ft. Lbs.) (Figure 104).
132. Remove all fuel from the fuel tank. (Refer to 09 - Engine/Fuel System/Standard Procedure) Use an appropriate fuel container. Dispose of the contaminated fuel using the proper procedures.

CAUTION: Dispose of petroleum-based products in a manner consistent with all applicable Local, State, Federal, and Provincial regulations.

133. Remove the fuel tank (Refer to 09 - Engine/Fuel System/TANK, Fuel/Removal and Installation) .
134. Ensure the swirl pot indentation below the in-tank electric fuel pump inlet is completely drained of any contaminated fuel and thoroughly clean the fuel tank.
135. Completely drain the low-pressure fuel lines and flush with clean diesel fuel, then install a **NEW** fuel filter.
136. Install the fuel tank and fill with clean diesel fuel. Do not connect the low pressure return to the tank at this time.
137. Install the appropriate Fuel Line Adapters / Fitting from the Decay Tool, Fuel 8978A to the low-pressure feed pipe at the HPFP. Route the opposite end of this hose into a suitable container.
138. Using a diagnostic scan tool, activate the fuel pump to fully purge the low-pressure feed line from the tank to the HPFP.
139. Connect the low-pressure feed line to the HPFP.
140. Connect a clean hose to the low pressure return line fitting at the tank and place the other end in a suitable clean container.
141. Using a diagnostic scan tool, activate the fuel pump to fully purge the low-pressure fuel return from the HPFP to the tank.
142. Connect the low pressure return line at the tank.
143. Install the fuel tank (Refer to 09 - Engine/Fuel System/TANK, Fuel/Removal and Installation).
144. Connect the negative battery cable(s). In Service Library, see 08 - Electrical / 8F - Engine Systems / Battery System / Standard Procedure / Battery Disconnect - Dual 12 Volt Battery System.
145. Start the engine and check for leaks.

SAFETY RECALL – NORTH AMERICA
High Pressure Fuel Pump



Reference: 01A / NHTSA 23V-263

FCA US LLC

146. Install the fuel injection pump blocker plate and the fuel injection pump blocker plate bolts to the fuel injection pump and tighten to 25 N·m (18 Ft. Lbs.) (Figure 102).
147. Connect the left CAC hose to the CAC and tighten the left CAC hose clamp (Figure 101).
148. Connect the Charge Air Cooler (CAC) hose to the EGR air flow control valve and secure the retaining lock (1) (Figure 100).
149. Set the air cleaner body and the clean air hose as an assembly into place and press down to seat it on its retainer. Install the air cleaner body bolt and tighten to 5 N·m (44 In. Lbs.).
150. Install the clamp at the turbocharger air inlet elbow (1). Slide the PCV hose (2) on at the head. Connect the Mass Air Flow electrical connector (3) (Figure 99).
151. Install the engine cover and engine cover bolts and tighten to 4 N·m (35 In. Lbs.) (Figure 98).
152. Install the cooling fan by pushing downwards and toward the radiator to seat it in its retainers (Figure 97).
153. Remove the piece of cardboard between the cooling fan and the radiator.
154. Install the right and left cooling fan bolts and tighten them to 8 N·m (71 In. Lbs.) (Figures 95 and 96).
155. Connect the cooling fan wire harness connectors and attach the wire harness connector to fan shroud (Figure 94).
156. Install the push pin retainers and upper radiator seal (Figure 93).
157. Close the hood and return the vehicle to the customer.

For vehicles with a non-contaminated fuel system, use the procedure below.

B. JL/JT Vehicles

Replace HPFP – Non-Contaminated System

WARNING: High-pressure lines deliver diesel fuel under extreme pressure from the injection pump to the fuel injectors. This may be as high as 2000 bar (29,008 psi). Use extreme caution when inspecting for high-pressure fuel leaks. Fuel under this amount of pressure can penetrate skin causing personal injury or death. Inspect for high-pressure fuel leaks with a sheet of cardboard. Wear safety goggles and adequate protective clothing when servicing fuel system.

WARNING: Observe the following precautions when working on fuel systems: No sparks, open flames or smoking. Avoid inhaling and swallowing fuel. Avoid eye and skin contact with fuel. Pour fuels only into suitable and appropriately marked containers. Wear protective clothing. Failure to observe these precautions may result in fire, explosion, property damage, and serious or fatal injury.

WARNING: High-pressure lines deliver diesel fuel under extreme pressure from the injection pump to the fuel injectors. This may be as high as 2000 bar (29,008 psi). Use extreme caution when inspecting for high-pressure fuel leaks. Fuel under this amount of pressure can penetrate skin causing personal injury or death. Inspect for high-pressure fuel leaks with a sheet of cardboard. Wear safety goggles and adequate protective clothing when servicing fuel system.

WARNING: Observe the following precautions when working on fuel systems: No sparks, open flames or smoking. Risk of poisoning from inhaling and swallowing fuel. Risk of injury to eyes and skin from contact with fuel. Pour fuels only into suitable and appropriately marked containers. Wear protective clothing.

NOTE: When key is cycled to the off position, fuel system pressure automatically bleeds down.

NOTE: The fuel injection pump can be replaced without having to perform the entire base engine valve timing procedure. This procedure gives instruction on how to remove and install the new fuel injection pump without performing the base engine timing. Do not rotate the pump shaft after removing from the vehicle. The alignment of the pump shaft must be measured and recorded using a commercially available degree wheel after the pump is removed and before transferring the pump gear over to the new pump. This is done to align the pump to the same position during installation. If the base engine valve timing must be performed as part of the repair, refer to Service Library 09 - Engine/Valve Timing/Standard Procedure.

This procedure is for the removal and installation of the fuel injection pump only. The fuel injection pump can be replaced without needing to perform the entire base engine valve timing procedure. This procedure gives instruction on how to properly align the new fuel injection pump. If the base engine valve timing must be performed, (Refer to 09 - Engine/Valve Timing/Standard Procedure). The timing of the pump is crucial, and the gear must not be moved once the pump is removed from the timing cover.

Battery Disconnect

1. On this dual battery system, the auxiliary battery ground cable connects to the main battery cable end (shown in generic graphic) and grounds through the main battery ground cable connection to the body, chassis or engine (depending on vehicle). Therefore, simply disconnecting and isolating the main battery negative cable clamp from the main battery post will not isolate the auxiliary from the vehicle's electrical system. The auxiliary battery will still be grounded through its connection to the main battery negative cable end. If both battery negative cables are not isolated, it will result in the vehicle electrical system and Power Distribution Center (PDC) still having battery connection which can cause vehicle wiring damage or deployment of air bags on re-connection (Figure 175). In Service Library, see 08 - Electrical / 8F - Engine Systems / Battery System / Standard Procedure / Battery Disconnect - Dual 12 Volt Battery System.

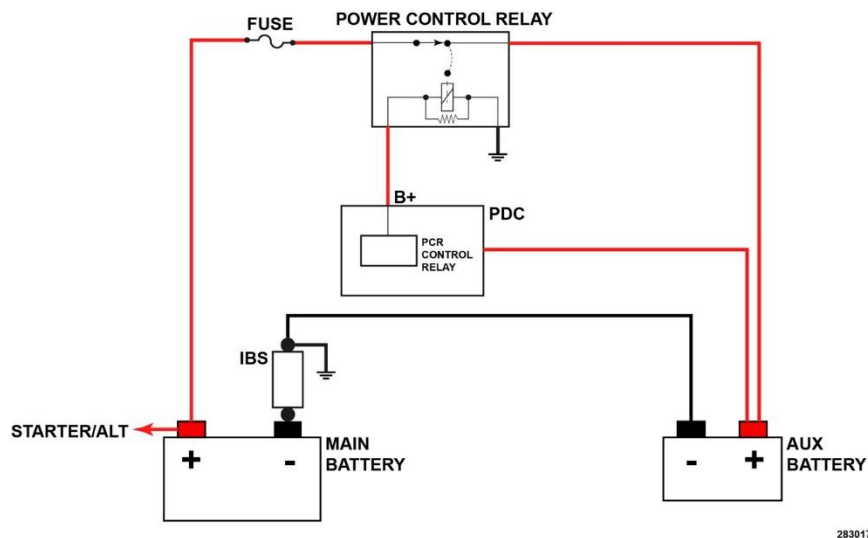

Figure 175 – Dual Battery System

2. Turn the ignition off. Wait five minutes to allow the main modules to go to sleep.
3. Disconnect and isolate the supplemental (auxiliary) battery negative cable from the main battery negative cable end. This will disconnect and isolate the auxiliary battery ground.
4. The main battery ground can be disconnected by removing the main battery negative cable from the negative battery cable end, or by disconnecting the IBS connector, loosening the negative battery clamp nut and removing the negative battery cable end from the battery post. Either method will disconnect the main battery. Both batteries should be disconnected from the vehicle electrical system.
5. Measure the voltage at the PDC positive battery cable connection to verify the vehicle electrical system is powered down.

NOTE: On some vehicles a small amount of voltage may be present (typically less than approximately 0.5 volts) due to capacitors in some modules still having voltage stored. Anything less than 1.0 volts should be safe.

Cooling Fan - Remove

6. Remove the push pins retainers (1) and upper radiator seal (2) (Figure 176).

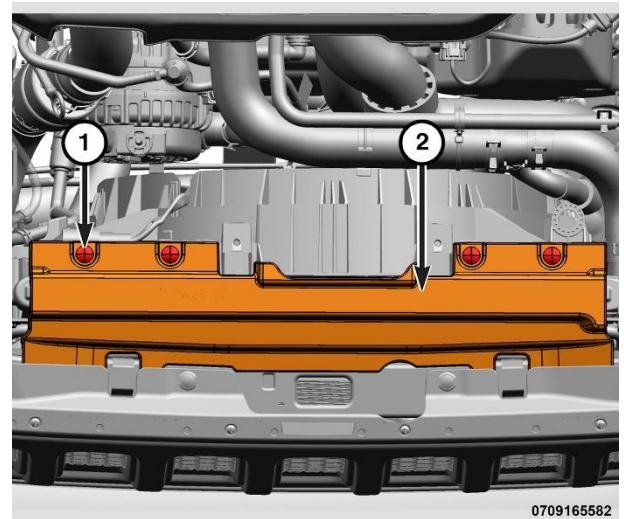

Figure 176 – Upper Radiator Seal

7. Disconnect the cooling fan wire harness connectors and detach the wire harness connector from fan shroud (1) (Figure 177).

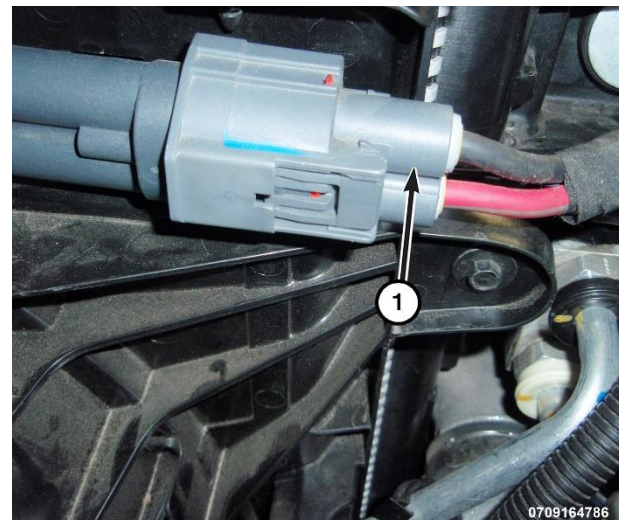

Figure 177 – Fan Electrical Connector

- 8. Remove the left cooling fan bolt (1) (Figure 178).

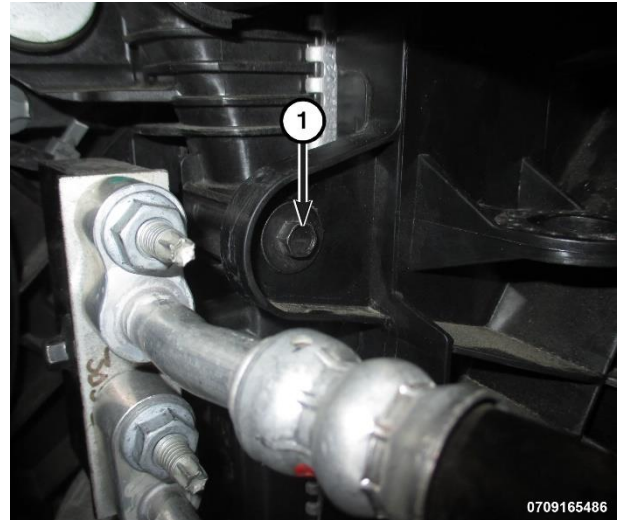

Figure 178 – Left Cooling Fan Bolt

- 9. Remove the right cooling fan bolt (1) (Figure 179).

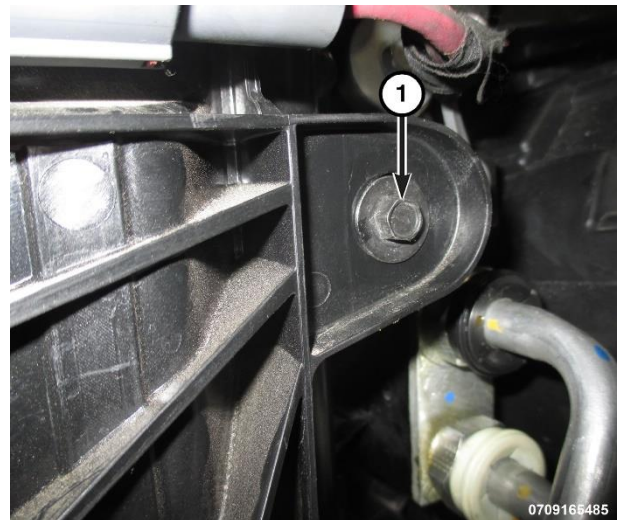

Figure 179 – Right Cooling Fan Bolt

SAFETY RECALL – NORTH AMERICA

High Pressure Fuel Pump



Reference: 01A / NHTSA 23V-263

FCA US LLC

10. Insert a piece of cardboard between the cooling fan and the radiator.
11. Remove the cooling fan (1) by pulling upwards and away from the radiator (Figure 180).

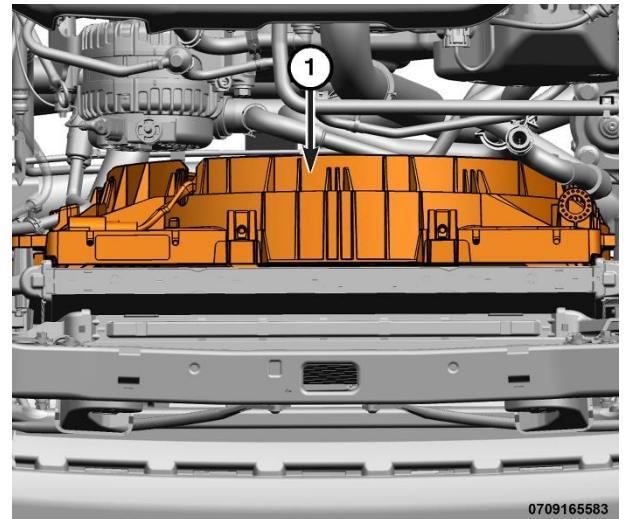

Figure 180 – Cooling Fan

SAFETY RECALL – NORTH AMERICA

High Pressure Fuel Pump



Reference: 01A / NHTSA 23V-263

FCA US LLC

12. Remove the fuel injection pump blocker plate bolts (2) and the fuel injection pump blocker plate (1) from the fuel injection pump (Figure 181).
13. Remove the fuel injection pump silencer.
14. Remove the engine cover.

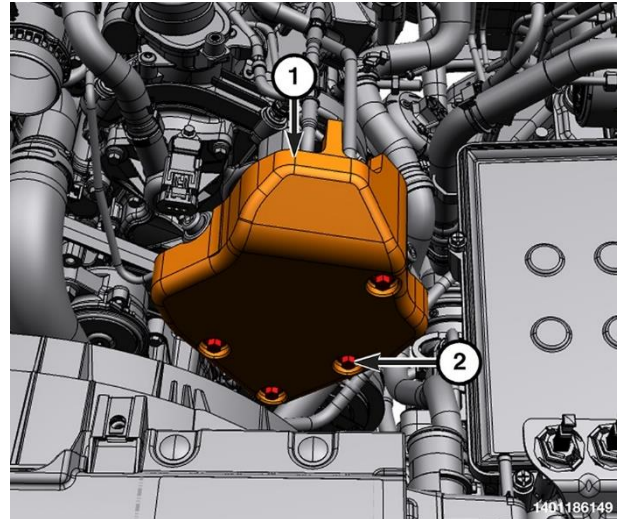

Figure 181 – HPFP Blocker Plate

15. Disconnect the crankcase breather hose (3) (Figure 182).
16. Disconnect the Closed Crankcase Ventilation (CCV) heater wire harness connector (1) and detach the wire harness retainer (2) (Figure 182).
17. Disconnect the clean air hose from the air cleaner body.

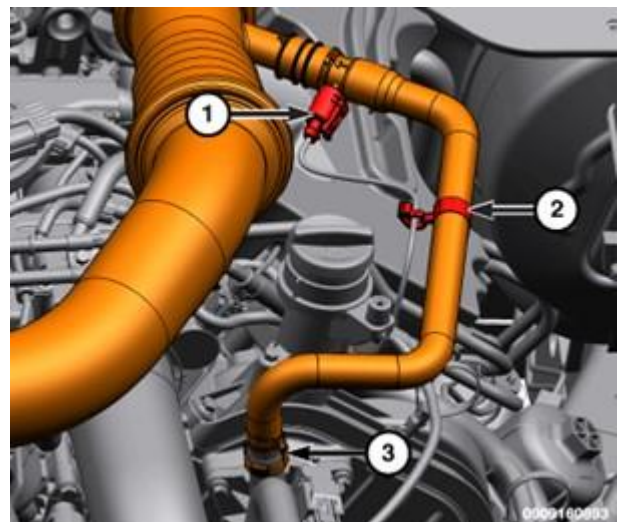

Figure 182 – Clean Air Hose

Strictly respect STELLANTIS Group safety, cleanliness, and environmental instructions for any intervention.
Document exclusively reserved for dealer information. Internal distribution to be ensured by dealer.
Reproduction forbidden without the written agreement of STELLANTIS Group.

(DJT)

SAFETY RECALL – NORTH AMERICA
High Pressure Fuel Pump



Reference: 01A / NHTSA 23V-263

FCA US LLC

- 18. Loosen clean air hose clamp (1) and remove the clean air hose from the turbocharger elbow (Figure 183).

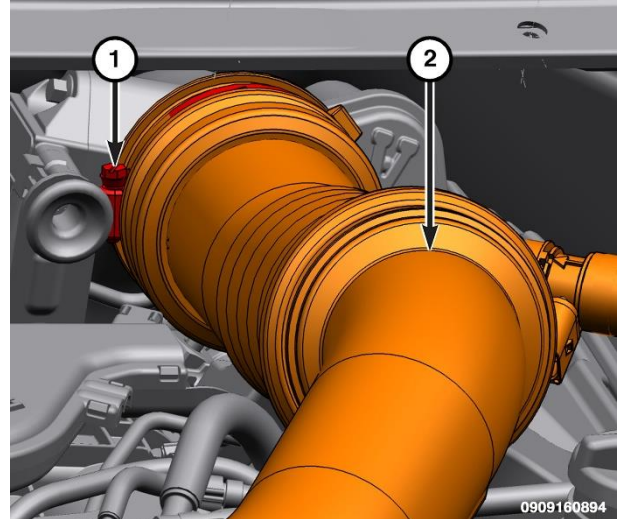

Figure 183 – Clean Air Hose at Turbo

- 19. Remove the vent hose from the left fuel rail cover.
- 20. Remove the left fuel rail cover bolts (1) and the left fuel rail cover (2) (Figure 184).

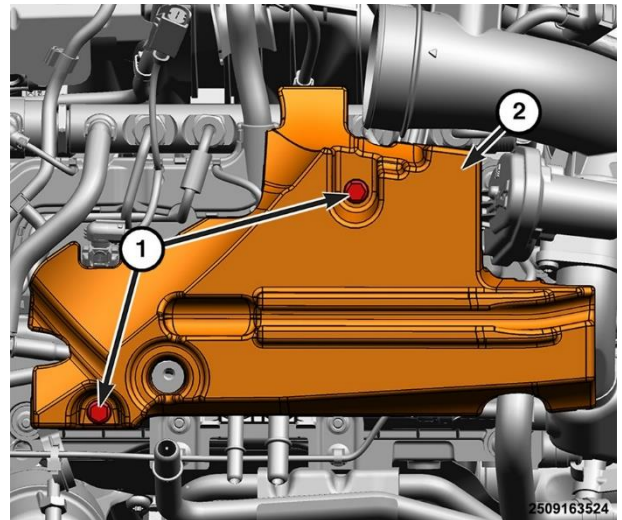

Figure 184 – Left Fuel Rail Cover

Strictly respect STELLANTIS Group safety, cleanliness, and environmental instructions for any intervention.
Document exclusively reserved for dealer information. Internal distribution to be ensured by dealer.
Reproduction forbidden without the written agreement of STELLANTIS Group.

(DJT)

SAFETY RECALL – NORTH AMERICA

High Pressure Fuel Pump



Reference: 01A / NHTSA 23V-263

FCA US LLC

21. Disconnect the low-pressure supply (2) and low pressure return lines (1) from the fuel injection pump (Figure 185).

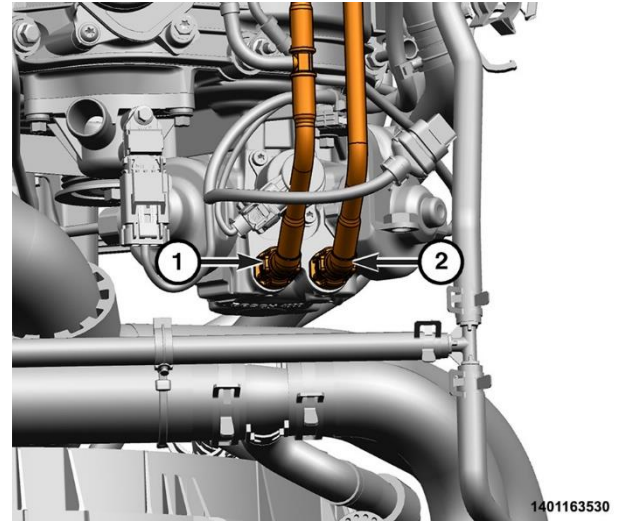

Figure 185 – Low Pressure Lines

22. Unscrew the union nuts (1 & 3) and remove cylinder No. 4 fuel tube (2) and discard the fuel tube (Figure 186).
23. Install protective caps onto the fuel injector and fuel rail.

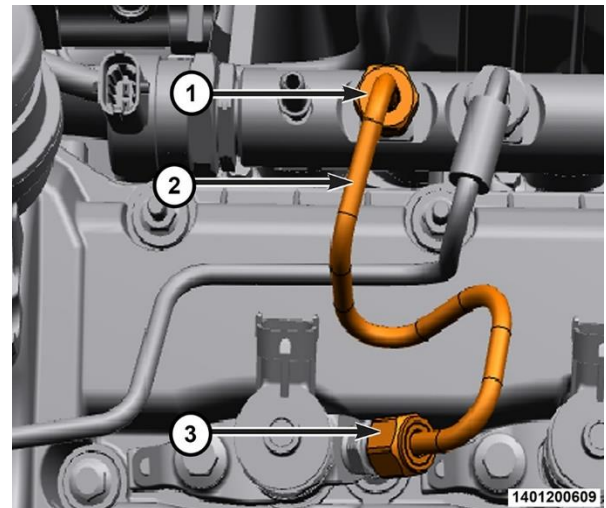

Figure 186 – No. 4 Fuel Tube

Strictly respect STELLANTIS Group safety, cleanliness, and environmental instructions for any intervention.
Document exclusively reserved for dealer information. Internal distribution to be ensured by dealer.
Reproduction forbidden without the written agreement of STELLANTIS Group.

(DJT)

SAFETY RECALL – NORTH AMERICA

High Pressure Fuel Pump



Reference: 01A / NHTSA 23V-263

FCA US LLC

24. Unscrew the fuel tube union nut from the fuel injection pump (3) (Figure 187).
25. Remove the fuel tube bracket nut (2) securing the fuel tube (Figure 187).
26. Unscrew the union nut from the fuel rail (1) and remove and discard the fuel tube (Figure 187).
27. Install protective caps onto the fuel injection pump and fuel rail.

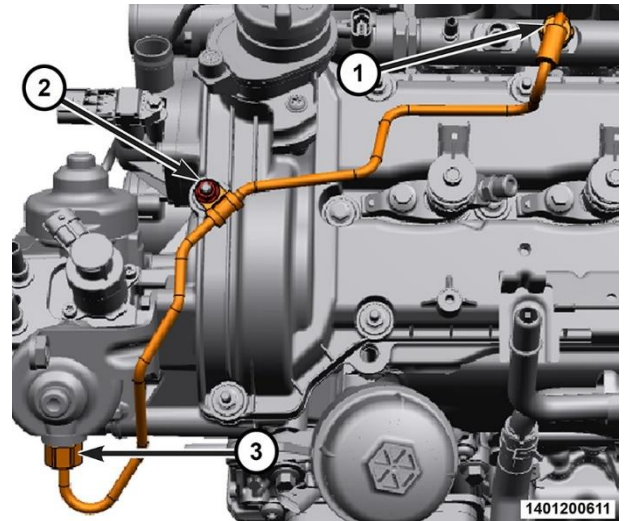

Figure 187 – Left Fuel Rail Supply Tube

28. Remove the Charge Air Cooler (CAC) hose bolt (2) securing the CAC hose to the support bracket (Figure 188).
29. Release the retaining clip (1) and disconnect the CAC hose from the turbocharger elbow and position aside (Figure 188).

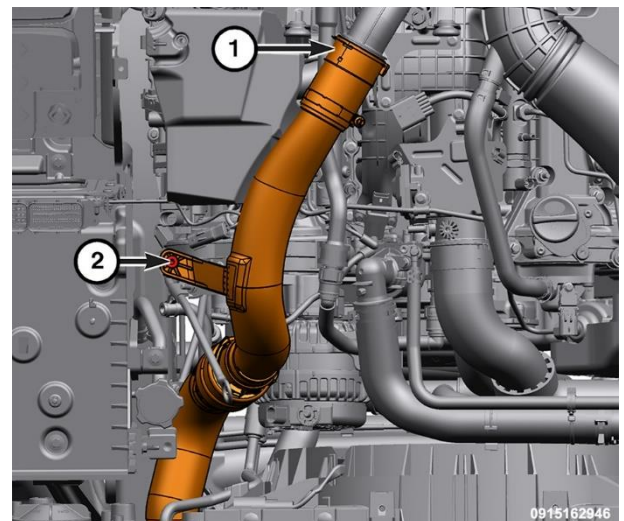

Figure 188 – Charge Air Cooler (CAC) Hose

Strictly respect STELLANTIS Group safety, cleanliness, and environmental instructions for any intervention.
Document exclusively reserved for dealer information. Internal distribution to be ensured by dealer.
Reproduction forbidden without the written agreement of STELLANTIS Group.

(DJT)

SAFETY RECALL – NORTH AMERICA
High Pressure Fuel Pump



Reference: 01A / NHTSA 23V-263

FCA US LLC

30. Loosen the right fuel rail cover nut (3), detach the wire harness retainer (1), and remove the fuel rail cover (2) (Figure 189).

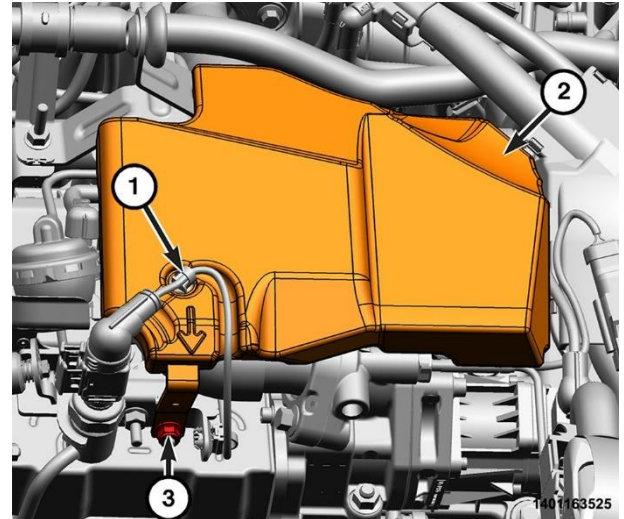

Figure 189 – Right Fuel Rail Cover

31. Release the retaining clip (1) and disconnect the CAC hose from the EGR air flow control valve (Figure 190).

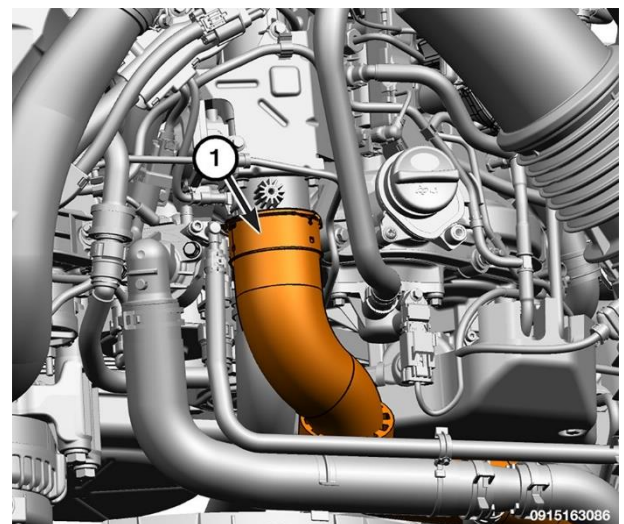

Figure 190 – CAC Hose

Strictly respect STELLANTIS Group safety, cleanliness, and environmental instructions for any intervention.
Document exclusively reserved for dealer information. Internal distribution to be ensured by dealer.
Reproduction forbidden without the written agreement of STELLANTIS Group.

(DJT)

SAFETY RECALL – NORTH AMERICA

High Pressure Fuel Pump



Reference: 01A / NHTSA 23V-263

FCA US LLC

- 32. Remove the fuel tube bolt (2) securing the fuel tube (191).
- 33. Unscrew the union nuts (1 & 4) and remove and discard the fuel tube (3) (Figure 191).
- 34. Install protective caps over the openings.

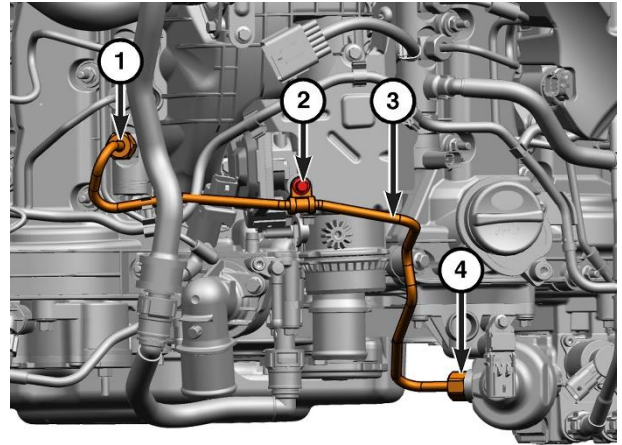

1401164943

Figure 191 – Right Fuel Rail Supply Tube

- 35. Disconnect the fuel quantity solenoid wire harness connector (2) (Figure 192).

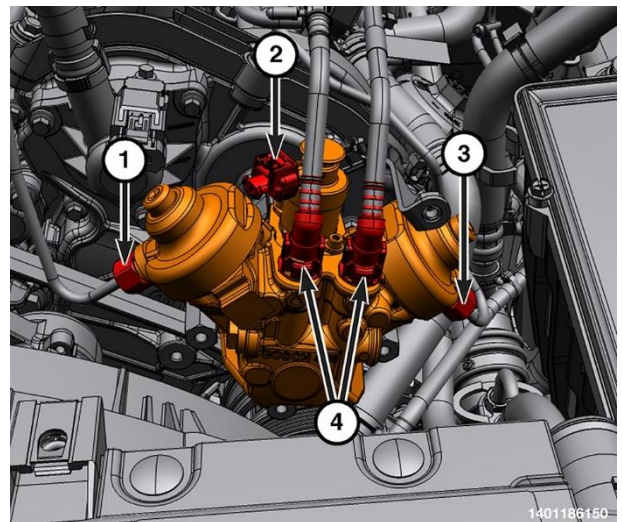

1401188450

Figure 192 – Fuel Quantity Solenoid Wire Harness Connector

Strictly respect STELLANTIS Group safety, cleanliness, and environmental instructions for any intervention.
Document exclusively reserved for dealer information. Internal distribution to be ensured by dealer.
Reproduction forbidden without the written agreement of STELLANTIS Group.

(DJT)

SAFETY RECALL – NORTH AMERICA

High Pressure Fuel Pump



Reference: 01A / NHTSA 23V-263

FCA US LLC

- 36. Remove the fuel injection pump upper bolts (1) from the fuel injection pump (Figure 193).
- 37. Install the Tool, High Pressure Pump Installation VM.10345 in the upper locations.

NOTE: The timing of the pump is crucial and the gear must not be moved once the pump is removed from the timing cover.

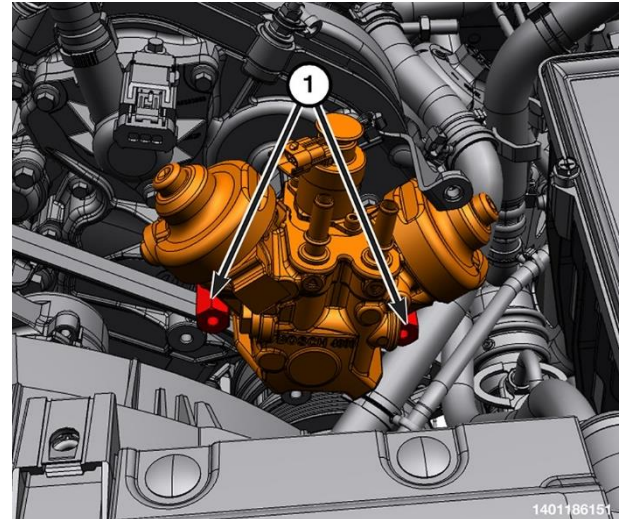

Figure 193 – HPFP Upper Bolts

- 38. Remove the fuel injection pump lower bolt (1) and the fuel injection pump (2) (Figure 194).

NOTE: The fuel injection pump needs to be timed using a commercially available degree wheel.

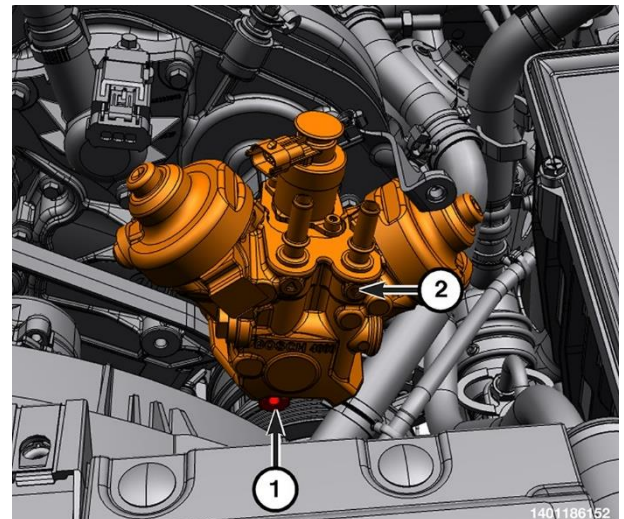

Figure 194 – HPFP Lower Bolt

SAFETY RECALL – NORTH AMERICA

High Pressure Fuel Pump



Reference: 01A / NHTSA 23V-263

FCA US LLC

- 39. Install the degree wheel onto the fuel injection pump with the zero at the fuel quantity solenoid then mark the location of the hole in the gear on the degree wheel (Figure 195).



Figure 195 – Installing a Printed Paper Degree Wheel from the Internet

- 40. Using a commercially available spanner wrench such as Blue Point APS351B, Snap-on APS351C or equivalent to hold fuel injection pump gear. Remove the fuel injection pump gear nut (Figure 196).

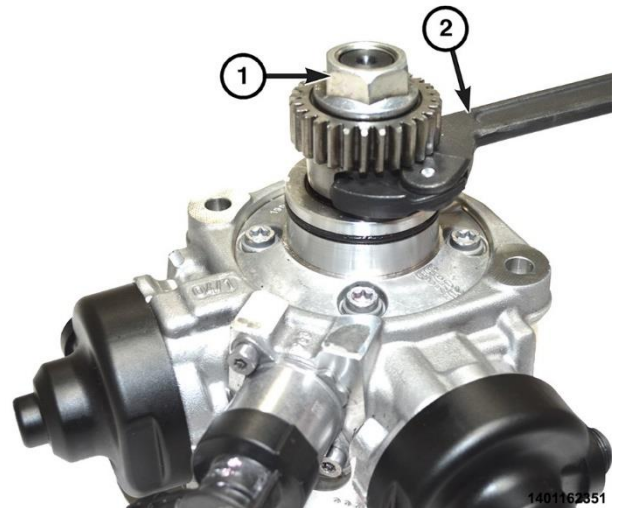
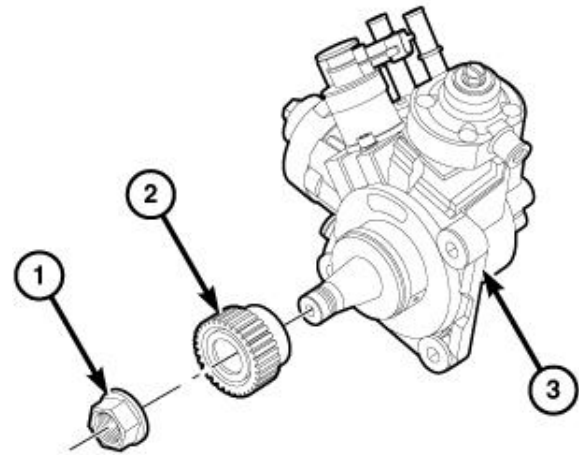

Figure 196 – Gear Nut Removal

Strictly respect STELLANTIS Group safety, cleanliness, and environmental instructions for any intervention.
Document exclusively reserved for dealer information. Internal distribution to be ensured by dealer.
Reproduction forbidden without the written agreement of STELLANTIS Group.

(DJT)

41. The use of Puller 1023 or a commercially available gear puller is required to remove the fuel injection pump gear (2) (Figure 197).



3361085

Figure 197 – Swapping the Drive Gear on the HPFP

WARNING: High-pressure lines deliver diesel fuel under extreme pressure from the injection pump to the fuel injectors. This may be as high as 2000 bar (29,008 psi). Use extreme caution when inspecting for high-pressure fuel leaks. Fuel under this amount of pressure can penetrate skin causing personal injury or death. Inspect for high-pressure fuel leaks with a sheet of cardboard. Wear safety goggles and adequate protective clothing when servicing fuel system.

CAUTION: Do Not Force the high-pressure pump into the right timing cover or attempt to seat it by drawing it in with the bolts. The pump gear must be properly aligned with the drive gear on the camshaft before the high-pressure pump will seat on the cylinder head mounting surface. Failure to properly align drive gears will damage the high-pressure pump or camshaft drive gear.

NOTE: The high-pressure pump needs to be timed before it can be installed. Use a commercially available degree wheel to time the high-pressure pump.

42. If removed, install the gear (2) and (1) nut onto the fuel injection pump (3) and tighten the nut finger tight (Figure 197).

SAFETY RECALL – NORTH AMERICA

High Pressure Fuel Pump



Reference: 01A / NHTSA 23V-263

FCA US LLC

- 43. Using a commercially available spanner wrench such as Blue Point APS351B, Snap-on APS351C or equivalent (2) and tighten the fuel injection pump gear nut (1) to 50 N·m (37 Ft. Lbs.) (Figure 198).

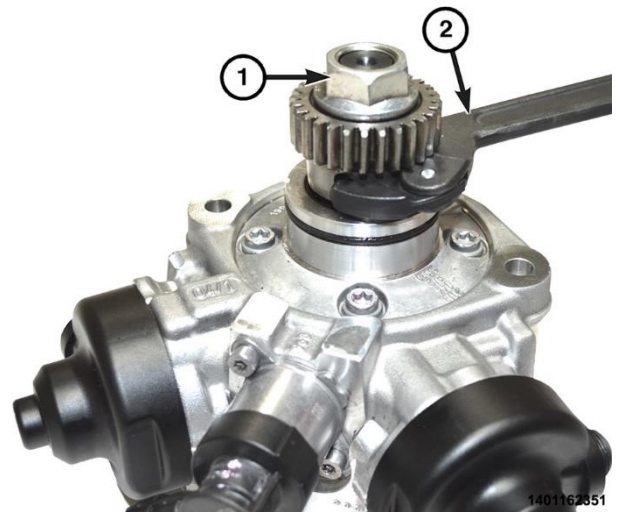

Figure 198 – Gear Nut Removal

- 44. Install the degree wheel with the zero aligned with the fuel quantity solenoid and rotate the pump shaft so that the hole aligns with the reference mark on the degree wheel referenced during the removal (Figure 199).



Figure 199 – Installing a Printed Paper Degree Wheel from the Internet

Strictly respect STELLANTIS Group safety, cleanliness, and environmental instructions for any intervention.
Document exclusively reserved for dealer information. Internal distribution to be ensured by dealer.
Reproduction forbidden without the written agreement of STELLANTIS Group.

(DJT)

SAFETY RECALL – NORTH AMERICA
High Pressure Fuel Pump



Reference: 01A / NHTSA 23V-263

FCA US LLC

- 45. Install a **NEW** O-ring to the high-pressure fuel injection pump (Figure 200).

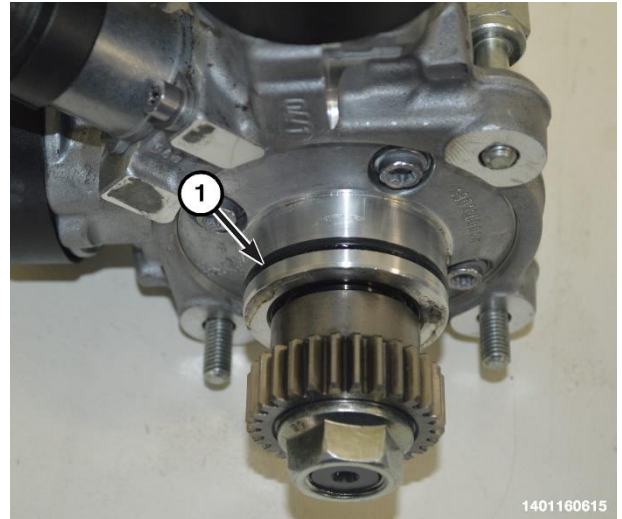

Figure 200 – O-ring

- 46. Install the fuel injection pump (2) onto the Tool, High Pressure Pump Installation VM.10345 into the studs installed in the upper timing cover (Figure 201).
- 47. Install the fuel injection pump and hand tighten the lower bolt (1) (Figure 201).

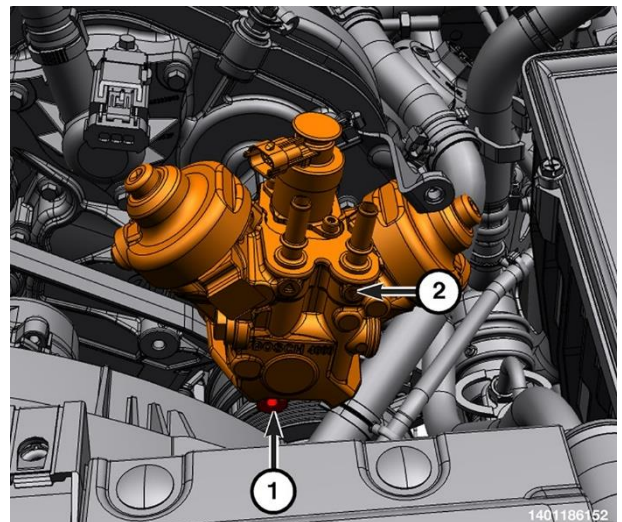

Figure 201 – HPFP Lower Bolt

Strictly respect STELLANTIS Group safety, cleanliness, and environmental instructions for any intervention.
Document exclusively reserved for dealer information. Internal distribution to be ensured by dealer.
Reproduction forbidden without the written agreement of STELLANTIS Group.

(DJT)

48. Remove the Tool, High Pressure Pump Installation VM.10345 and install the high-pressure fuel injection pump upper bolts (Figure 193).
49. Tighten the high-pressure fuel injection pump upper and lower bolts to 25 N·m (18 Ft. Lbs.).
50. Connect the fuel quantity solenoid wire harness connector (2) (Figure 192).
51. Connect the low-pressure fuel supply/return lines (4) (Figure 192).
52. Remove the protective caps over the openings.

NOTE: Fuel tubes are a onetime only use and must be replaced anytime they have been removed.

53. Start the union nuts (1 & 4) on the **NEW** fuel tube (3). Tighten the union nuts (1,3) to 11 N·m + 75° (8 Ft. Lbs. + 75°) (Figure 191).
54. Install the fuel tube bolt (2) securing the fuel tube and tighten securely (191).
55. Connect the CAC hose to the EGR air flow control valve and secure the retaining clip (1) (Figure 190).
56. Install the fuel rail cover (2), attach the wire harness retainer (1), and tighten the right fuel rail cover nut (3) to 5 N·m (44 In. Lbs.) (Figure 189).
57. Install the Charge Air Cooler (CAC) hose bolt (2) securing the CAC hose to the support bracket and tighten to 11 N·m (8 Ft. Lbs.) (Figure 188).
58. Attach the retaining clip (1) and connect the CAC hose from the turbocharger elbow (Figure 188).
59. Remove protective caps from the fuel injection pump and fuel rail.
60. Install the **NEW** fuel tube. Hand tighten the union nuts to the fuel rail (1) and tighten to 11 N·m + 75° (8 Ft. Lbs. + 75°) (Figure 187).
61. Install the fuel tube bracket nut (2) securing the fuel tube and tighten to 8 N·m (71 In. Lbs.) (Figure 187).
62. Hand tighten the fuel tube union nut to the fuel injection pump (3) and tighten to 11 N·m + 75° (8 Ft. Lbs. + 75°) (Figure 187).
63. Remove protective caps from the fuel injector and fuel rail (Figure 186).
64. Hand tighten the union nuts (1 & 3) and install a **NEW** cylinder No. 4 fuel tube (2). Tighten the union nuts to 11 N·m + 75° (8 Ft. Lbs. + 75°) (Figure 186).
65. Install the left fuel rail cover (2) and bolts (1) and tighten to 5 N·m (44 In. Lbs.) (Figure 184).
66. Install the vent hose to the left fuel rail cover.
67. Install the clean air hose to the turbocharger elbow and securely tighten the clean air hose clamp (1) (Figure 183).
68. Connect the clean air hose to the air cleaner body (Figure 182).

SAFETY RECALL – NORTH AMERICA
High Pressure Fuel Pump



Reference: 01A / NHTSA 23V-263

FCA US LLC

69. Connect the Closed Crankcase Ventilation (CCV) heater wire harness connector (1) and attach the wire harness retainer (2) (Figure 182).
70. Connect the crankcase breather hose (3) (Figure 182).
71. Install the engine cover.
72. Install the fuel injection pump silencer.
73. Install the fuel injection pump blocker plate (1) to the fuel injection pump. Install the fuel injection pump blocker plate bolts (2) and tighten 25 N·m (18 Ft. Lbs.) (Figure 181).
74. Install the cooling fan (1) to the radiator (Figure 180).
75. Remove the piece of cardboard between the cooling fan and the radiator.
76. Install the right and left cooling fan bolts and tighten them to 8 N·m (71 In. Lbs.) (Figures 178 and 179).
77. Connect the cooling fan wire harness connectors and attach the wire harness connector to fan shroud (Figure 177).
78. Install the push pin retainers and upper radiator seal (Figure 176).
79. Connect the negative battery cables. In Service Library, see 08 - Electrical / 8F - Engine Systems / Battery System / Standard Procedure / Battery Disconnect - Dual 12 Volt Battery System.
80. Start engine and check for leaks.

For all platforms above (DT, JL, JT) and both contaminated and non-contaminated systems, complete step **C**.
Install the Authorized Modifications Label.

C. Install the Authorized Modifications Label:

1. Type or print (with a ballpoint pen) the necessary information shown in (Figure 202) onto the authorized modifications Label.

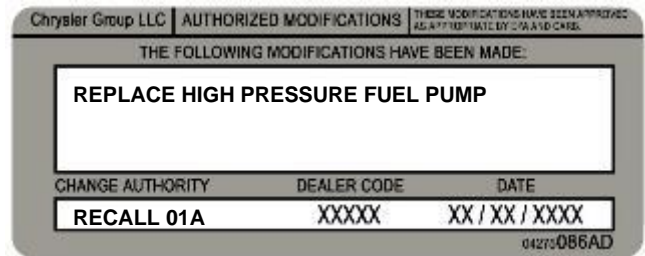

Figure 202 – Authorized Modifications Label

2. Remove the paper backing from the clear film on the front of the authorized modifications label then carefully apply the clear film over the front of the authorized modifications label (Figure 203).

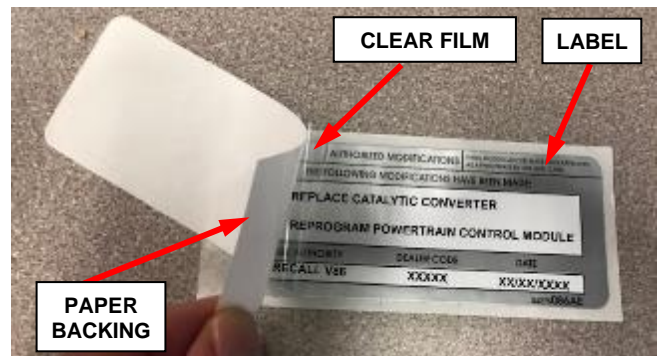

Figure 203 – Apply Clear Film

SAFETY RECALL – NORTH AMERICA
High Pressure Fuel Pump



Reference: 01A / NHTSA 23V-263

FCA US LLC

NOTE: The Authorized Modifications Label should be located near the Vehicle Emission Control Information (VECI) label (Figure 204).

3. Locate the VECI label on the underside of the engine compartment hood (Figure 204).

NOTE: For vehicles missing a VECI label, locate a flat protected area on the underside of the hood to apply the authorized modifications label.

4. Clean the surface near the VECI label with isopropyl alcohol or equivalent and a soft cloth.



**Figure 204 – Apply Authorized Modifications Label Near VECI Label
(Specific Vehicle May Look Different)**

5. Remove the authorized modifications label from its paper backing.
6. Apply the authorized modifications label next to the VECI label (Figure 204).
7. Firmly press and smooth the authorized modifications label to ensure good adhesion.
8. Close the engine compartment hood.
9. Complete the Proof of Correction Form for California Residents, **Section D**.

D. Complete Proof of Correction Form for California Residents:

This recall is subject to the **State of California Registration Renewal/Emissions Recall Enforcement Program**. Complete a Vehicle Emission Recall Proof of Correction Form (**Form No. 81-016-1053**) and **supply it to vehicle owners residing in the state of California** for proof that this recall has been performed when they renew the vehicle registration.

Process Steps to obtain the California Proof of Correction form:

- a. Access the “**DealerCONNECT**” website.
- b. Select the “**Service**” tab.
- c. Under the “**Publications**” heading, select the “**ePublishing**” link.
- d. Sign in using your **Dealer Code** and **Password**.
- e. Select the “**Proof of Correction form**”.

E. Owner’s Manual Addendum and Tip Card:

From Campaign kit CSFP01A1AA, place the Owner’s Manual Addendum in the glovebox with the Owner’s Manual.

Place the Tip Card in a conspicuous location that will be visible to the driver so that they will review it. Suggestions would be the top of the instrument panel, in front of the instrument cluster, etc. Please review the information on the card with the owner when the vehicle is returned to them.

F. Fuel Door Label:

NOTE: Do not apply the label over an existing label. Apply the label on a flat surface on the inside of the fuel door. For example, on the top of the fuel door hinge (Figure 206).

From Campaign kit CSFP01A1AA, install the fuel door decal.

1. Open the fuel door.
2. Clean the top surface of the hinge with isopropyl alcohol or equivalent and a soft cloth. Repeat as needed until the soft cloth comes off the surface clean.
3. Remove the fuel door label from its paper backing.
4. Apply the fuel door label (Figure 205) to the top of the fuel door hinge (Figure 206).
5. Firmly press and smooth the fuel door label to ensure good adhesion.
6. Close the fuel door.



Figure 205 – Fuel Door Label

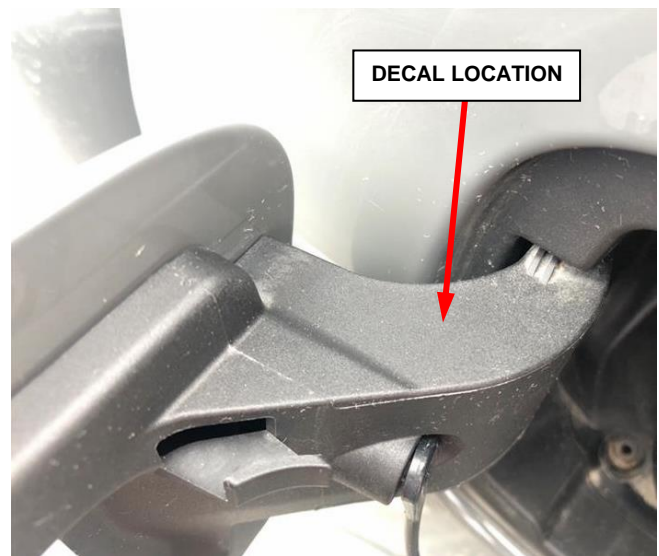

Figure 206 – Fuel Door Hinge Location

This notice applies to your vehicle,

[Model Year and Model]

VIN XXXXXXXXXXXXXXXXXXXX

01A/NHTSA 23V-263

LOGO

VEHICLE PICTURE

YOUR SCHEDULING OPTIONS

- 1. RECOMMENDED OPTION**
Call your authorized Chrysler / Dodge / Jeep® / RAM Dealership.
- 2. Call the FCA Recall Assistance Center at 1-800-853-1403.** An agent can confirm part availability and help schedule an appointment.
- 3. Visit recalls.mopar.com, scan the QR code below, or download the Mopar Owner's Companion App.**

QR Code

Get access to recall notifications, locate your nearest dealer, and more through this website or Mopar Owner's Companion App. You will be asked to provide your Vehicle Identification Number (VIN) to protect and verify your identity. The last eight characters of your VIN are provided above.

DEALERSHIP INSTRUCTIONS

Please reference Safety Recall 01A.

IMPORTANT SAFETY RECALL

High Pressure Fuel Pump

Dear [Name],

This notice is sent to you in accordance with the National Traffic and Motor Vehicle Safety Act.

FCA US LLC, has decided that a defect, which relates to motor vehicle safety, exists in certain [2021 through 2023 Model Year (JL) Jeep® Wrangler and (JT) Gladiator] vehicles.

It is extremely important to take steps now to repair your vehicle to ensure the safety of you and your passengers.

WHY DOES MY VEHICLE NEED REPAIRS?

The **High-Pressure Fuel Pump (HPFP)** on your vehicle ^[1] **may fail prematurely.** A HPFP failure may introduce internally failed component debris into the fuel system potentially causing fuel starvation. **Fuel starvation may result in an unexpected loss of motive power, which can cause a vehicle crash without prior warning.**

HOW DO I RESOLVE THIS IMPORTANT SAFETY ISSUE?

FCA US will repair your vehicle ^[2] free of charge (parts and labor). To do this, your dealer will replace the HPFP, inspect and, if necessary, replace additional fuel system components. The estimated repair time is estimated to be between 2 hours to 7 hours depending on the repair needed. In addition, your dealer will require your vehicle for proper check-in, preparation, and check-out during your visit, which may require more time. Your time is important to us, so we recommend that you schedule a service appointment to minimize your inconvenience. Please bring this letter with you to your dealership.

**TO SCHEDULE YOUR FREE REPAIR,
CALL YOUR CHRYSLER, DODGE, JEEP OR RAM DEALER TODAY**

CALIFORNIA RESIDENTS

The State of California requires the completion of emission recall repairs prior to vehicle registration renewal. Your dealer will provide you with a Vehicle Emission Recall Proof of Correction Form after the Safety Recall service is performed. Be sure to save this form since the California Department of Motor Vehicles may require that you supply it as proof that the Safety Recall has been performed.

In order to ensure your full protection under the emissions warranty provisions, it is recommended that you have your (vehicle or engine) serviced as soon as possible. Failure to do so could be determined as lack of proper maintenance of your (vehicle or engine).

WHAT IF I ALREADY PAID TO HAVE THIS REPAIR COMPLETED?

If you have already experienced this specific condition and have paid to have it repaired, you may visit www.fcarecallreimbursement.com to submit your reimbursement request online. ^[3] Once we receive and verify the required documents, reimbursement will be sent to you within 60 days. If you have had previous repairs performed and/or already received reimbursement, you may still need to have the recall repair performed.

We apologize for any inconvenience, but are sincerely concerned about your safety. Thank you for your attention to this important matter.

Customer Assistance/Field Operations
FCA US LLC



Mr. Mrs. Customer
1234 Main Street
Hometown, MI 48371

[1] If you no longer own this vehicle, please help us update our records. Call the FCA Recall Assistance Center at 1-800-853-1403 to update your information.

[2] If your dealer fails or is unable to remedy this defect without charge and within a reasonable time, you may submit a written complaint to the Administrator, National Highway Traffic Safety Administration, 1200 New Jersey Ave., S.E., Washington, DC 20590, or you can call the toll-free Vehicle Safety Hotline at 1-888-327-4236 (TTY 1-800-424-9153), or go to safercar.gov.

[3] You can also mail in your original receipts and proof of payment to the following address for reimbursement consideration: FCA Customer Assistance, P.O. Box 21-8004, Auburn Hills, MI 48321-8007, Attention: Recall Reimbursement.

Note to lessors receiving this recall notice: Federal regulation requires that you forward this recall notice to the lessee within 10 days.