

SAFETY RECALL

Volvo Trucks North America

Greensboro, NC USA

VOLVO

Date	Number	Release	Page
05.2023	RVXX2303	02	1(4)

**Volvo Active Drive Assist
VNR**

RECALL INFORMATION

Updated Repair Instructions and Labor Codes

May (2023)

Volvo Trucks has determined that certain VNR Electric model trucks equipped with adaptive cruise control could experience an overly aggressive braking event during regenerative braking when lightly loaded. Overly aggressive braking could cause rear axle skidding and loss of control resulting in vehicle crash.

Volvo trucks is currently working on a remedy program and once available there will be a follow up service campaign to provide a solution. Dealers and customers will be notified when the remedy is available.

Volvo Trucks has not received any complaints or reports of injury; therefore, Volvo considers this as a proactive measure to protect the public and Volvo's customers from the potential risk associated with this defect.

Currently, Volvo Trucks is requiring the removal of the front radar, its bracket and installation of a par file. Please follow instruction below to complete.

VEHICLES AFFECTED

Certain 2020 to 2023 Volvo VNR electric model vehicles manufactured from April 16, 2019 through October 19, 2022.

VEHICLE QUANTITY

There are 241 vehicles affected by this recall (238 U.S.,3 Canada).

Parts Information

	Part Description	Part Number	Quantity
1	Connector Cap	24202558	1
2	Cavity Plug Seal	22036053	10
3	Tie straps	20817302	4
4	Windshield Label (English)	24585112	1
5	Harness Label (English)	24585120	1
	If French Labels are needed.		
6	Windshield Label (French)	24585122	1
7	Harness Label (French)	24585115	1

Parts Ordering

Order using normal process.

Repair Instructions

1. Park the vehicle on level surface.
2. Apply parking brake.
3. Place the transmission in park or neutral.
4. Turn off ignition.
5. Install wheel chocks.

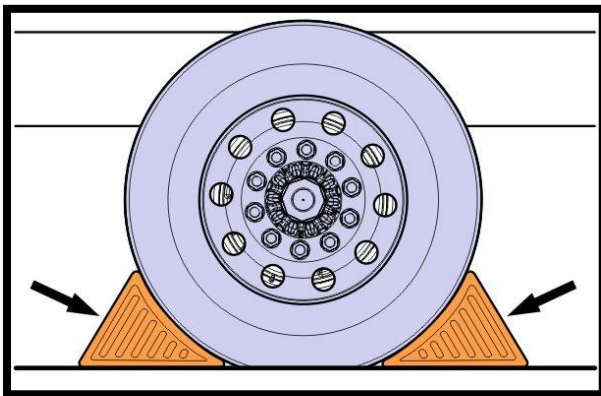

6. Perform inspection to determine the state of truck, if radar and bracket is not installed, harness is capped and tied back, and labels are installed you can skip to step 36.
7. Disconnect all external power supply or charging devices.

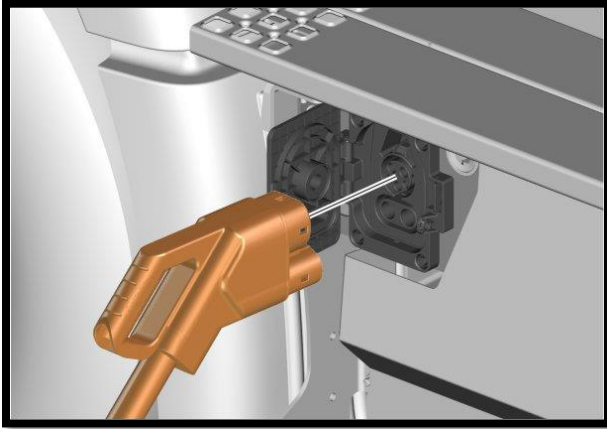

8. Lock the access to the CCS (Combined Charging System).

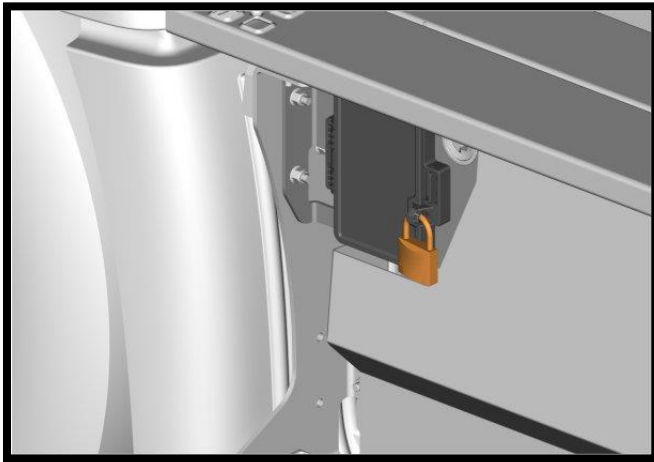

9. Set the chassis switch to position (1).
Switch, position

Position	Status
1	OFF
2	ON

10. Remove the safety pin from the slot (A) and install in the slot (B).

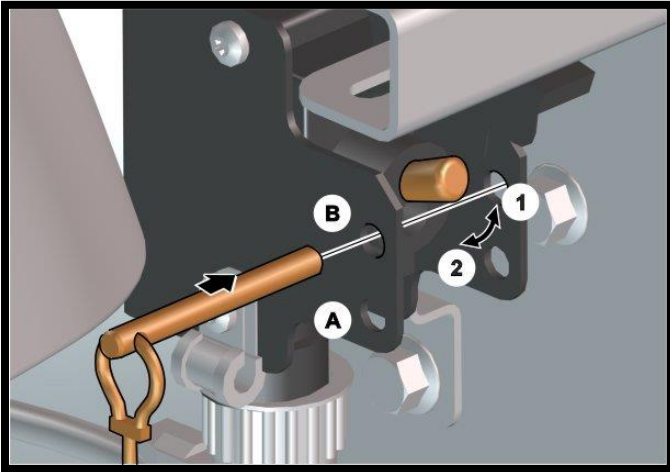

11. Remove battery cover bolts.

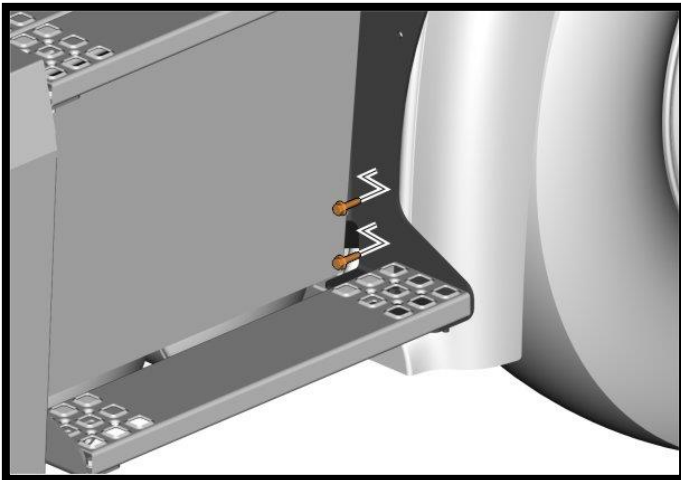

12. Remove battery cover nuts and remove cover.

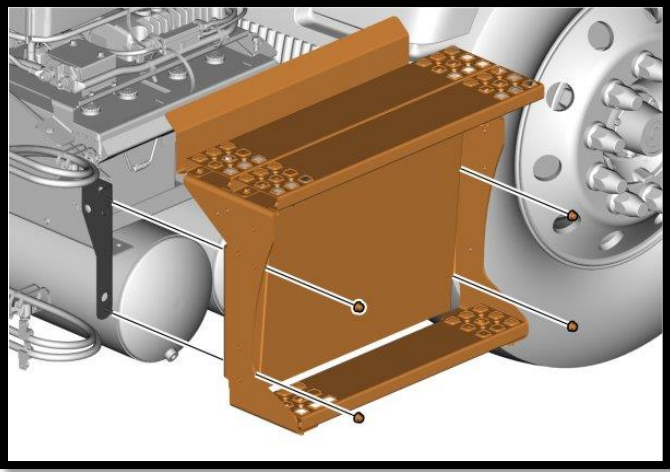

13. Remove fuse covers

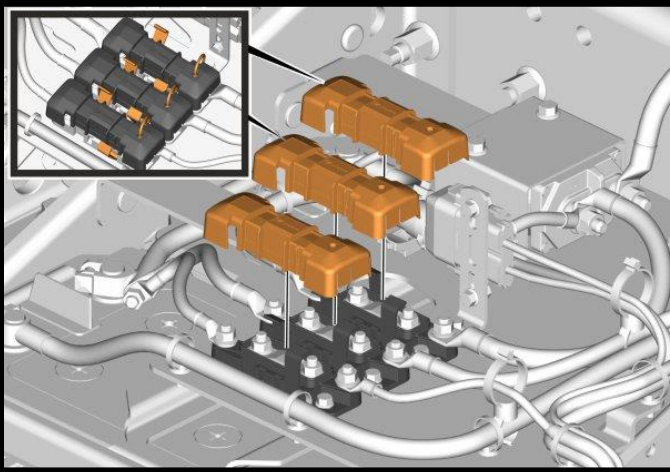

14. Remove Fuses.

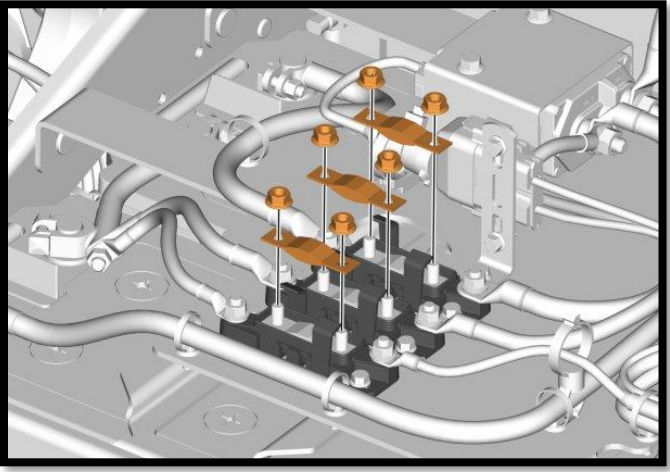

15. Disconnect the cable from the negative terminal.

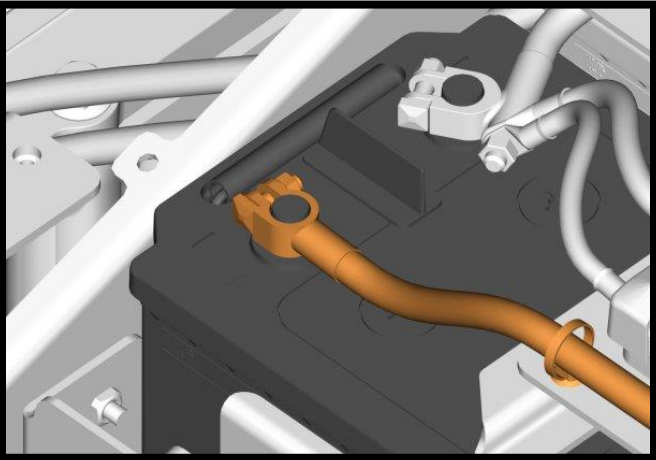

16. Cover negative battery post.

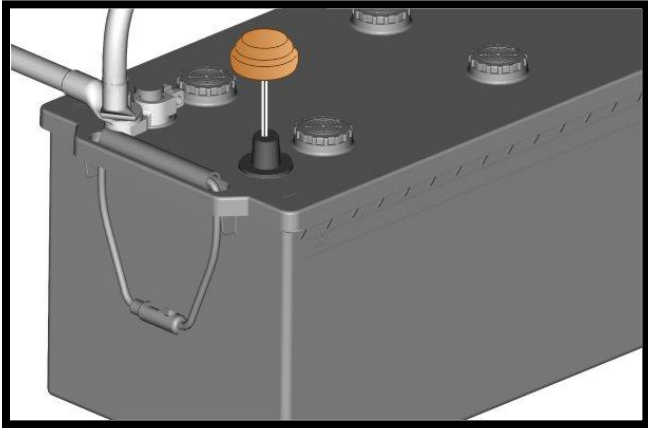

17. Lock the negative terminal along with fuses.

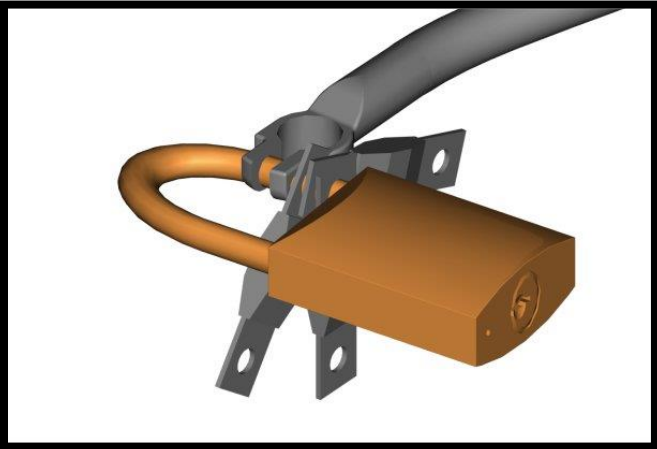

Important Note

Not all trucks were shipped the same. Some parts may not have been installed or have already been removed. Because of this, some of the following instructions may not apply to all trucks. You can skip steps as needed but please review all steps to ensure every truck has the same outcome.

18. Disconnect the forward-facing radar.

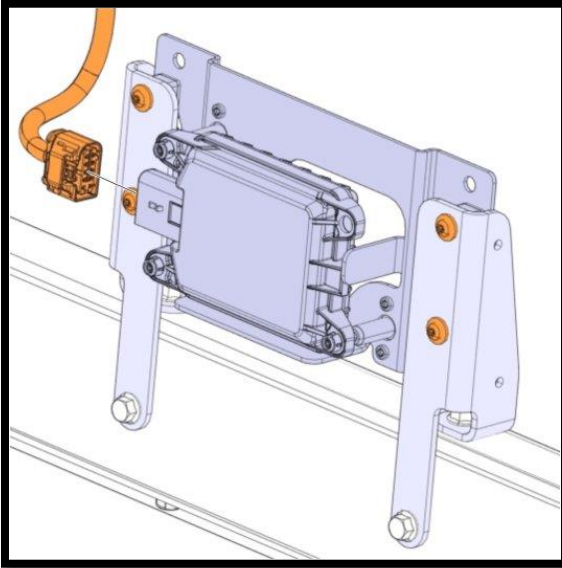

19. Remove the tie straps circled below.

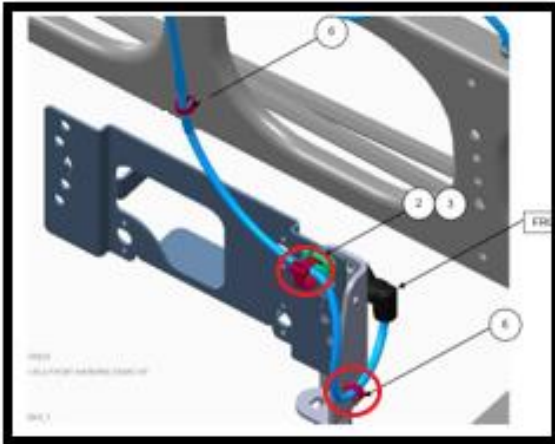

20. Remove forward-facing radar and bracket as an assembly.

Important Note
If only the bracket is installed it will need to be removed in the same manner.

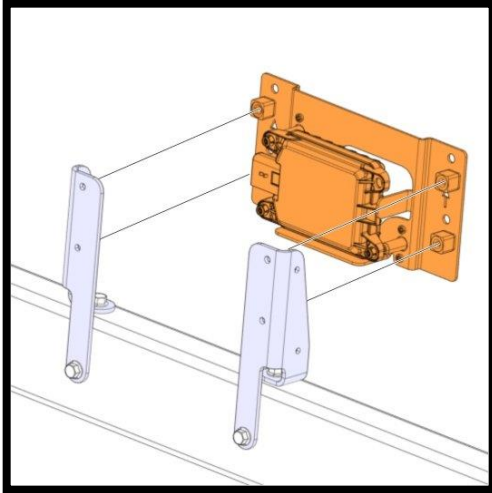

21. Install connector seals into connector cap and slide yellow locking tab to the locked position.

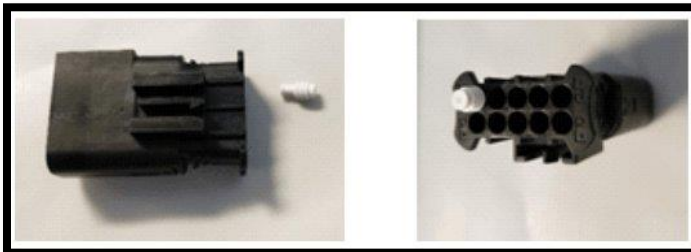

22. Install connector cap onto harness.



23. Wrap warning label (P/N-24585120) around radar harness within an inch of the radar connector.



24. Tie back harness as pictured below.

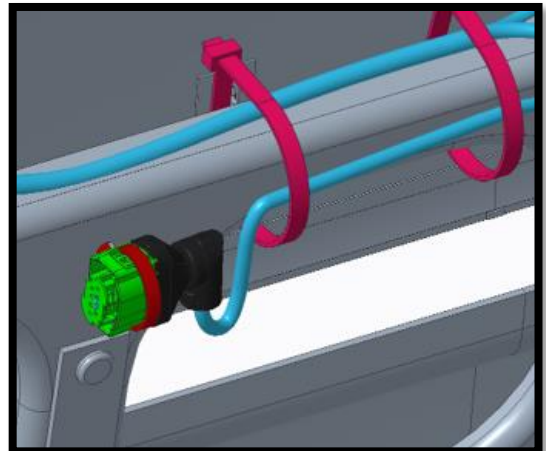
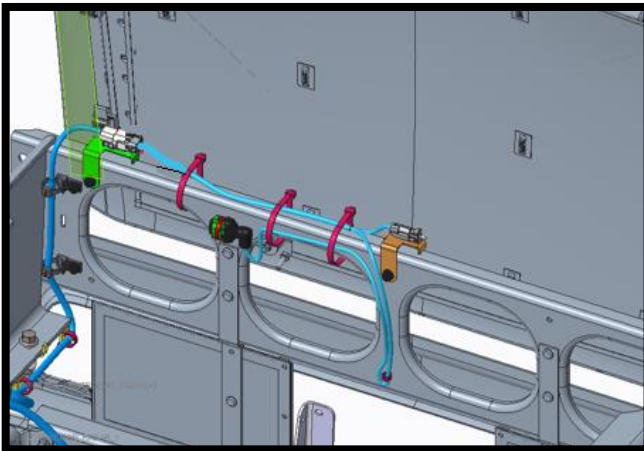

25. Place warning label (P/N-24585112) in top left-hand corner of windshield. If there is a label already there that pertains to VADA place new label over top of it.



26. Unlock the negative terminal and fuses.

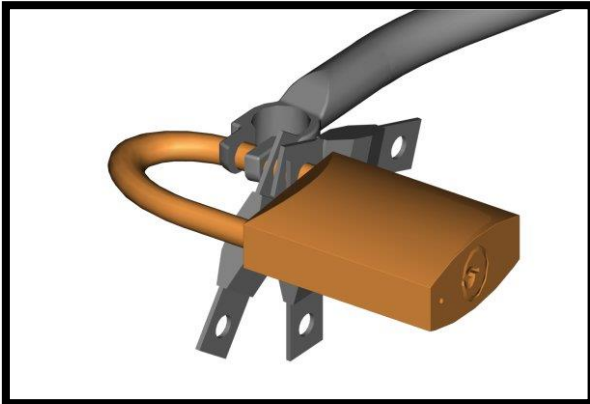

27. Remove negative battery post cover.

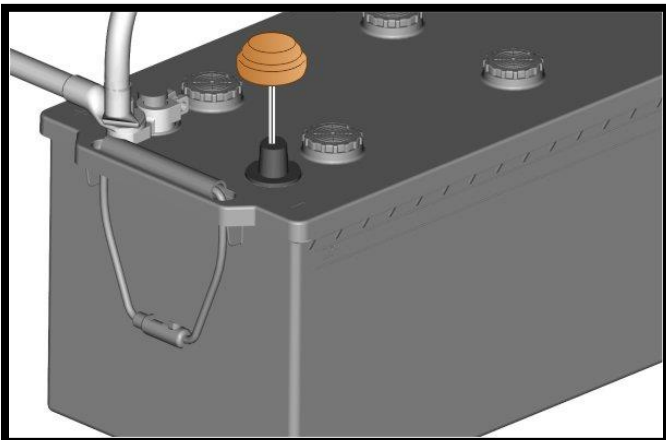

28. Connect the cable to the negative terminal.

Tightening torque	
Cable terminal, nut	4.5 ±0.5 Nm (3 ±0.4 lb _r -ft)

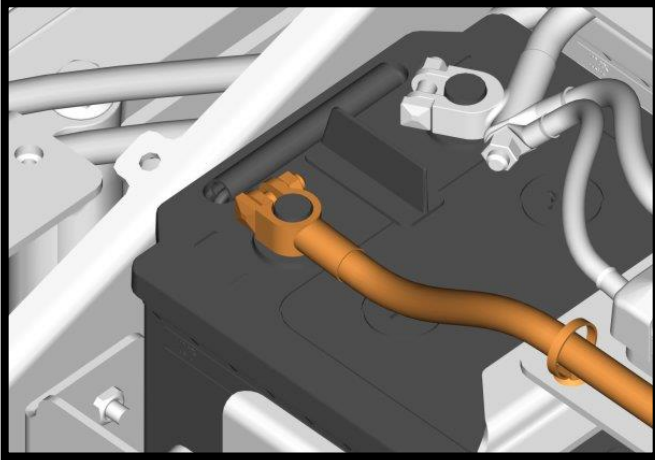

29. Install fuses.

Tightening torque	
Fuse, nut	15 ±3 Nm (11 ±2 lb _r -ft)

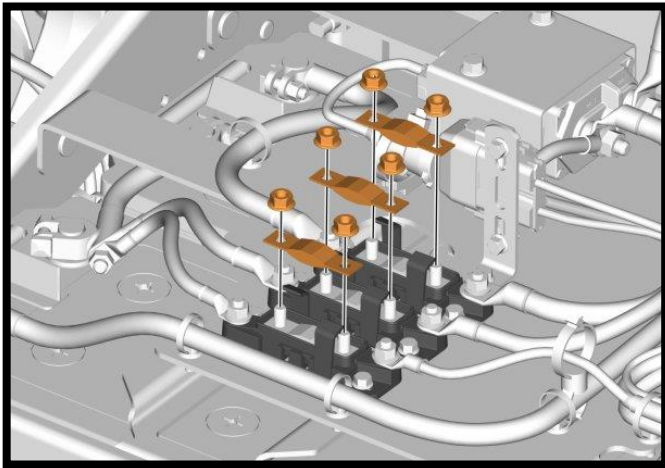

30. Install fuse covers.

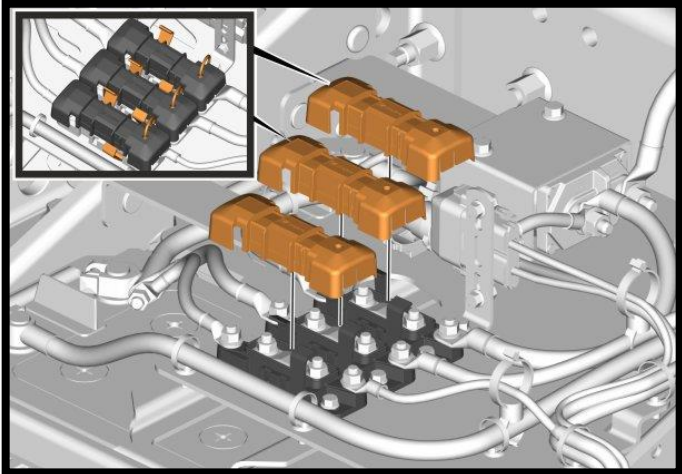

31. Install battery cover and install nuts.

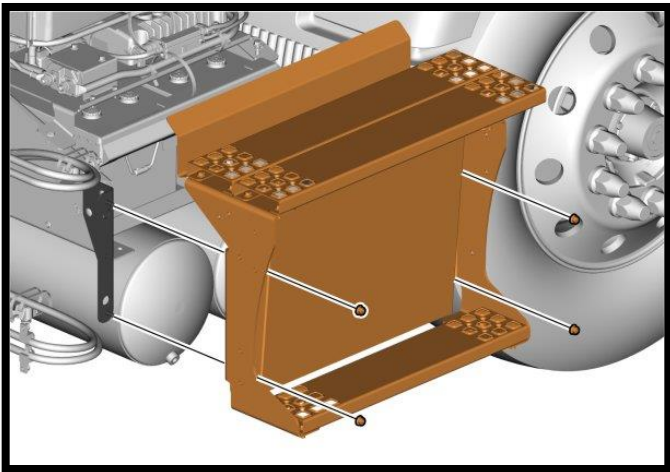

32. Install bolts.

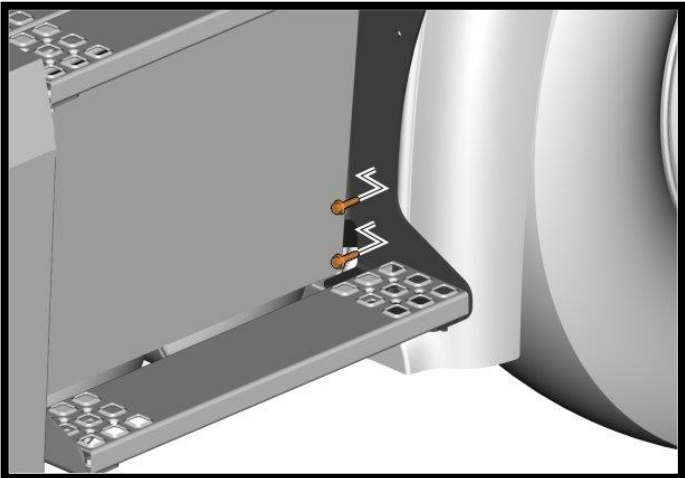

33. Remove the safety pin from slot (B) and install in slot (A).

34. Set the chassis switch to position (2).

Switch, position

Position	Status
1	OFF
2	ON

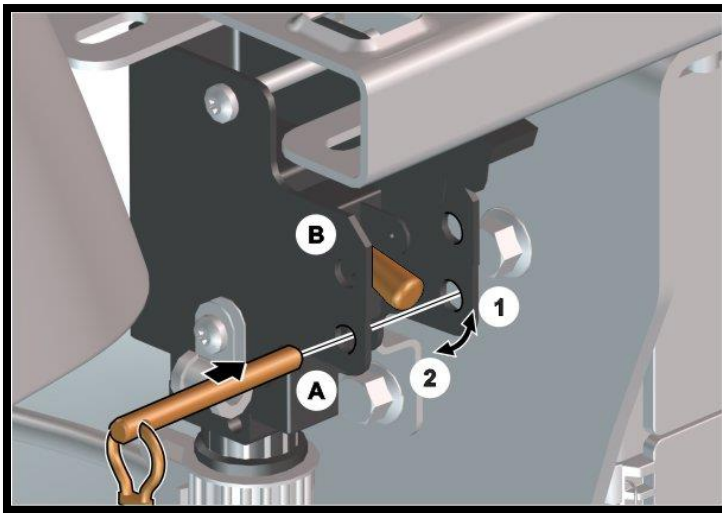

35. Unlock the access to the CCS.

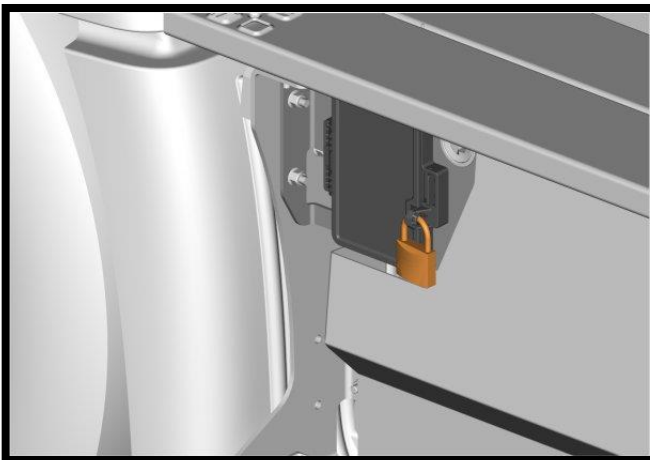

36. Turn on ignition

37. Connect truck to PTT and update ABS .par file with new file on the server.



Important Note

Please ensure ABS .par file is updated even if the truck arrived for service with all parts removed and labels installed. Please also ensure dash look like pictures below.

38. After programming, please ensure the following pop-ups and warning lights appear on dash.



39. Please print two copies of the last page of this document. Leave one copy in the truck for the driver and install the second copy in the owner's manual pouch.

40. Remove wheel chocks.

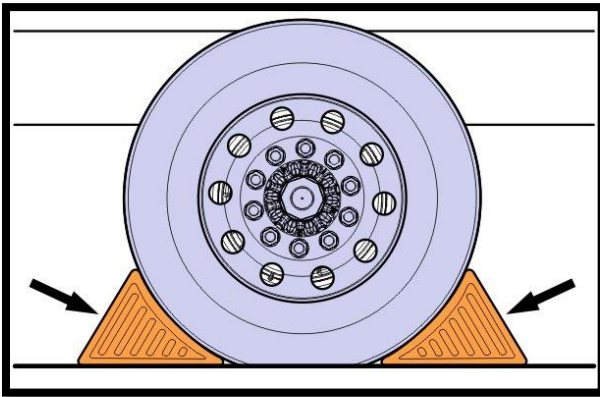

41. Return truck to service.

Parts Return

All removed part must be returned to TMAC, to trigger return you must select **Replace** when filing in UCHP. If no parts were removed, you must select **Repair**.

Causal part		
Prefix	Part no.	Description
<input type="text"/>	<input type="text"/>	

Replaced Repaired

Important Note
Whether or not the truck had a radar and bracket or just a bracket all removed parts need to be returned to TMAC.

REIMBURSEMENT

This repair is covered by an authorized Non-Compliance recall. Reimbursement is obtained through the normal claim handling process.	
	UCHP Reimbursement
Claim Type (used only when uploading from the Dealer Business System)	40
Recall Status	
Vehicle repaired per instructions	1-Modified per instructions
If only inspection and .par file update was performed	
Main Labor Code Programming:1700-22-03-11	0.3
Labor Codes	
Main Labor Code Programming:1700-22-03-11	0.3
Low Voltage System, Decommission Labor Code: 3100-09-01-04	0.3
Low Voltage System, Commission Labor Code: 3100-09-01-05	0.3
Warning labels install labor code:1720-16-09-01	0.1
Only use if radar or bracket were installed and had to be removed.	
Radar and bracket removal labor code:1720-16-09-01x2	0.2
Causal Part	23792796
Authorization Number	C0294

Note: Dealers are to perform this Safety Recall Campaign on all subject vehicles at no charge to the vehicle owner regardless of mileage, age of vehicle or ownership (original purchaser or subsequent purchasers). Whenever vehicles are subject to a Safety Recall are brought to your dealership for service, or taken into your dealership vehicle inventory, it is strongly recommended that every effort be made to perform the recall correction before the vehicle is sold or released to the owner.

Print and install in owner's manual pouch.

DRIVER INSTRUCTIONS FOR VEHICLE OPERATION WITHOUT VOLVO ACTIVE DRIVER ASSIST (VADA) FRONT RADAR



Features that are available	Features that are <i>not</i> available
<ul style="list-style-type: none">Standard vehicle cruise controlLane departure warningVehicle data loggers with a web portalRight-hand blind spot detection	<ul style="list-style-type: none">Forward collision warning and collision mitigationAdaptive Cruise Control; including active brakingTraffic sign recognition

The below pop-up messages will appear when ignition is turned on. Press "ok" on toggle switch in steering wheel to acknowledge pop-ups



Yellow check light and Adaptive Cruise Control (ACC) icon with a red diagonal line will remain on



The diagnostics menu in the truck will show 4 active fault codes. If the vehicle has any faults in addition to the 4 active fault codes listed below, please contact Volvo Action Service or your local dealer for service.

VECU-SA 36 DTC U103F87
ABS-SA11 SPN 639 FMI 2

IC-MID 140 PSID 211 FMI 9
LCM-MID 216 PSID 211 FMI 9