

May 16, 2023

Version 3

Safety Recall: 2007–11 CR-V Rear Frame Brace

Supersedes 23-032, dated May 2, 2023, to revise the information

AFFECTED VEHICLES

Year	Model	Trim	VIN Range
2007–11	CR-V	ALL	Check the iN VIN status for eligibility.

REVISION SUMMARY

This service bulletin has been extensively revised, American Honda recommends you read this bulletin in its entirety.

BACKGROUND

In salt belt states where de-icing agents are used to maintain the roadway, the de-icing agents, along with mud and dirt, could enter the rear frame through the rear frame drainage points. This de-icing mixture can accumulate along the rear frame, where it connects to the rear suspension trailing arm. Over time, accumulated de-icing agents/mud/dirt mixture may cause internal corrosion. As a result of this condition, the rear suspension trailing arm may detach/separate while driving, increasing the risk of a crash.

The vehicle may be deemed not repairable after an inspection, depending upon the condition of the vehicle and inspection results. Notify the customer prior to work being started.

CUSTOMER NOTIFICATION

Owners of affected vehicles will be sent a notification of this safety recall.

Do an iN VIN status inquiry to verify eligibility.

Some vehicles affected by this campaign may be in your new or used vehicle inventory.

Failure to repair a vehicle subject to a recall or campaign may subject your dealership to claims or lawsuits from the customer or anyone else harmed as a result of such failure. To see if a vehicle in inventory is affected by this safety recall, do a VIN status inquiry before selling it.

CORRECTIVE ACTION

Install the trailing arm holder kit.

PARTS INFORMATION

Part Name	Part Number	Quantity
Trailing Arm Holder Kit	06730-SWA-325	1

CUSTOMER INFORMATION:The information in this bulletin is intended for use only by skilled technicians who have the proper tools, equipment, and training to correctly and safely maintain your vehicle. These procedures should not be attempted by "do-it-yourselfers," and you should not assume this bulletin applies to your vehicle, or that your vehicle has the condition described. To determine whether this information applies, contact an authorized Honda automobile dealer.

TOOLS INFORMATION

Part Name	Part Number	Quantity
3/8" X 3/4" Drill Guide	07AAG-SWAA200	1
True Digital Video Inspection Scope	BK5600DUAL55	1

This tool has been auto-shipped to dealers in the salt-belt states. It is available to dealers outside of the salt-belt states through the normal parts ordering process.

REQUIRED MATERIALS

Part Name	Part Number	Quantity
3/8" HSS Drill Bit (One drill bit repairs 7 vehicles).	07AAH-SWAA100	1

NOTE: Available through the normal parts ordering process.

WARRANTY CLAIM INFORMATION

Operation Number	Description	Flat Rate Time	Defect Code	Symptom Code	Template ID	Failed Part Number
4185A1	Inspect the rear suspension (includes photos and video clip).	0.5 hr	6RA00	UE300	A23032A	52370-SWA-A01
4181E5	Install the trailing arm holder kit (includes inspection).	0.8 hr	6RA00	UE300	A23032B	52370-SWA-A01

INSPECTION PROCEDURE

1. Put the vehicle on a lift.
2. Position the lift blocks under the vehicle's front support points and rear support points.

NOTE: If the vehicle's support points are compromised due to corrosion, please use best shop practices to lift the vehicle.

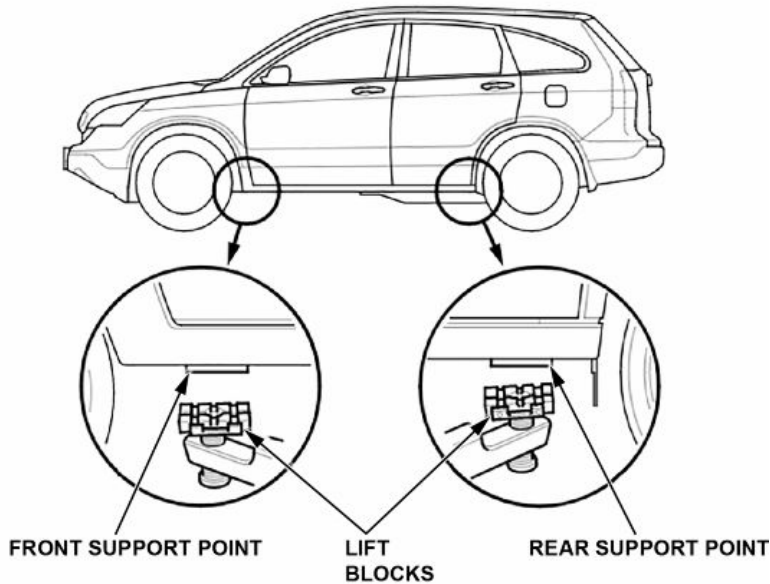

3. Raise the lift a few inches, and rock the vehicle gently to be sure it is firmly supported.
4. Raise the lift to its full height and inspect the vehicle support points for solid contact with the lift blocks.
5. Remove both rear wheels.
6. Place an under-hoist stand under the trailing arm for support.

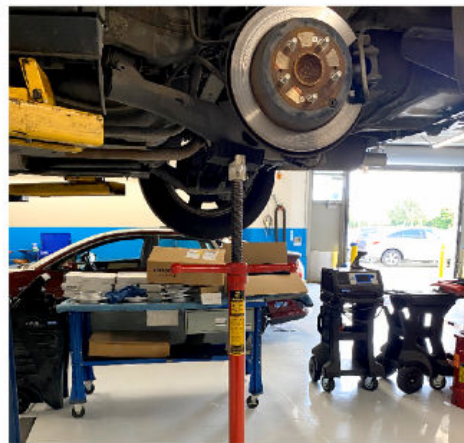

7. Using an impact gun, attempt to remove the trailing arm front mounting bolt.

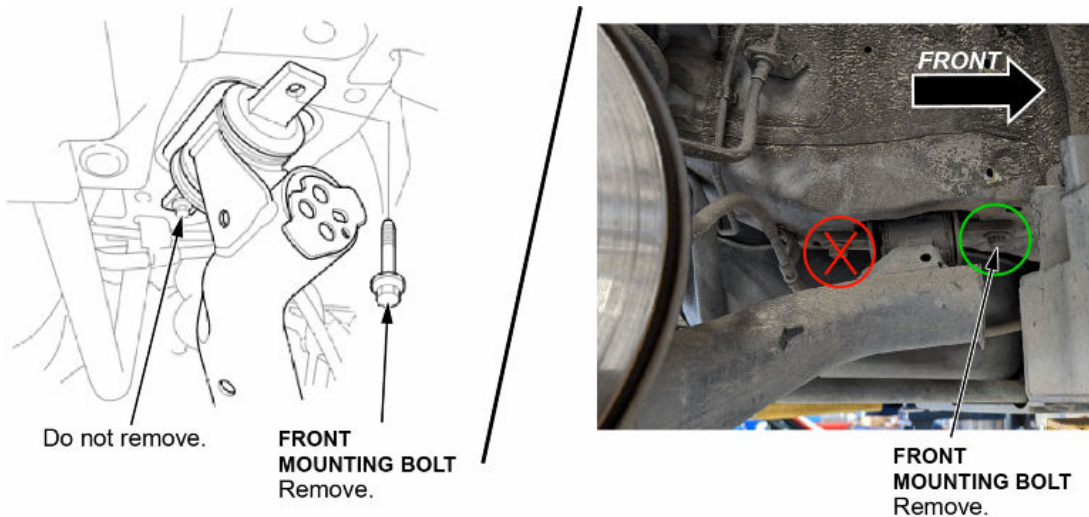

NOTE:

- **No punch testing is required.** Any perforation noted near the trailing arm mounts is not a concern; the trailing arm is supported by the inner upper frame structure. **Do not remove the trailing arm rear bolt.**
- If both the front and rear trailing arm bolts are removed, wheel alignment is required.
- If the bolt does not loosen after attempting to use more force (i. e., higher torque impact gun, breaker bar) install the wheels.

Was the trailing arm front mounting bolt removed successfully?

YES - If successfully able to remove the trailing arm front mounting bolt, reinstall and torque the trailing arm bolt to **115 N·m (84.6 lb-ft)** and continue to the repair procedure.

NO - If the trailing arm front mounting bolt spins freely without being removed or the bolt does not loosen, re-install the wheels and inform your Service Manager and/or Shop Foreman. The vehicle is not eligible for repair and the Trailing Arm Holder kit cannot be installed on the vehicle.

State on the Repair Order that the vehicle was not fixed and the issue remains. Have the vehicle owner sign the R/O acknowledging the inspection results and retain a copy of the R/O.

For trailing arm front bolts that do not loosen, take the required photos of the vehicle as shown in the PHOTOGRAPH REQUIREMENTS section below. You will need to submit the photo files along with the warranty claim. Upload your photos to Tech Line using the Tech Line Image Uploader tool on the iN. Create a Tech Line contact using iN and with the access code contact Tech Line by phone to confirm receipt of the photos and vehicle inspection details.

For trailing arm front bolts that spin freely without being removed, a short 3 second video at (720P and 20Mb max) will be required. Email the video to techline@ahm.honda.com and include "23-032 and VIN XXXX" in the subject line to provide the VIN number of the vehicle. Create a Tech Line contact using the iN and with the access code contact Tech Line by phone to confirm receipt of the photos and vehicle inspection details.

8. Repeat steps 6 and 7 on the opposite side.

PHOTOGRAPH REQUIREMENTS

REAR TRAILING ARM FRONT BOLT TEST – UNSUCCESSFUL REMOVAL

- 9. Photo of VIN label on the left B-pillar.

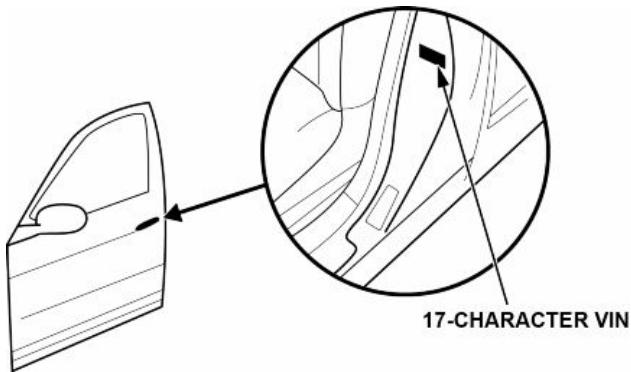

- 10. Photo of the odometer reading (not the trip reading).
- 11. Photos of the failed trailing arm mount.

For trailing arm front bolts that do not loosen, take the following photos as shown below:

NOTE: The following photos are to be captured using the previously provided borescope Snap-on BK5600DUAL55 or any equivalent commercially available tool. The reference pictures below show the borescope entry locations and camera orientation, as well as examples of the stiffener inner structure.

Photo of the trailing arm mount collar.

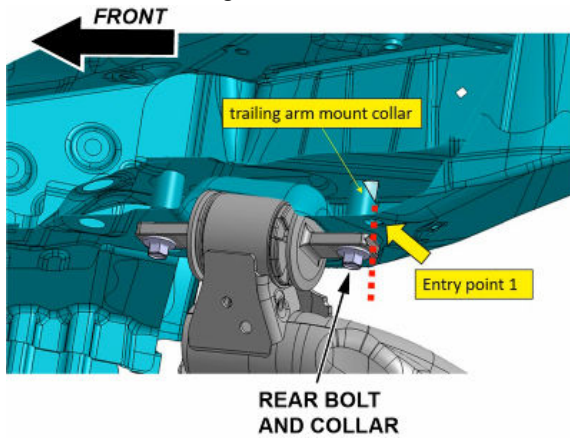

EXAMPLE OF TRAILING ARM COLLAR REAR BOLT MOUNT

Photo of the trailing arm mount nut.

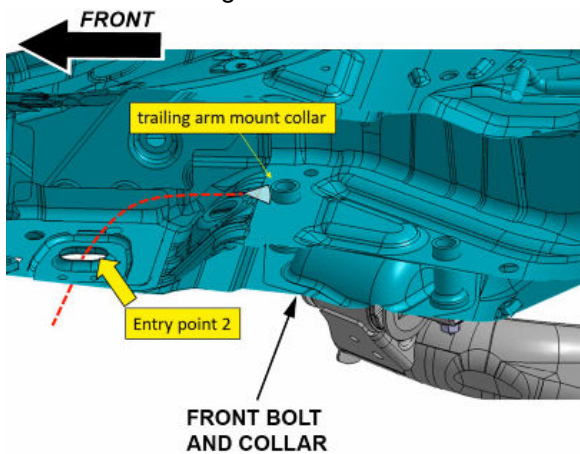

EXAMPLE OF TRAILING ARM COLLAR FRONT MOUNT

For trailing arm front bolts that spin, take a 3 second video clip showing the trailing arm front bolt spinning. Video should be 720p resolution and under 20Mb in size.



NOTE: Video clip will need to be emailed to techline@ahm.honda.com, and include "23-032 and VIN XXXX" in the subject line to provide the VIN number of the vehicle.

REPAIR PROCEDURE

1. From the trailing arm holder kit, install the bolt guide wire around the threads of the 10x62 bolt. Then, insert into the frame insert washer.

NOTE: Make sure the engraving THIS SIDE UP on the washer is facing up.

BOLT GUIDE WIRE



Pay close attention to the marking "THIS SIDE UP" on the frame insert.

FRAME INSERT WASHER

NOTE: Due to an excessive layer of protected zinc (galvanized bolt), the **10mm** nut is difficult to hand tighten. Before installing the guide wire clean the bolt threads. Use a **10mm x 1.25mm** machine thread die or, if a tool is not available, use a socket or wrench to move the **10mm** nut up and down the bolt (10x62) until the bolt and nut can be hand-tightened.



**10mm x 1.25
MACHINE THREAD DIE**



10mm NUT POSITION

2. Insert the assembled bolt with guide wire and frame insert washer into the underbody opening.



Insert the head of the bolt through the drain hole.

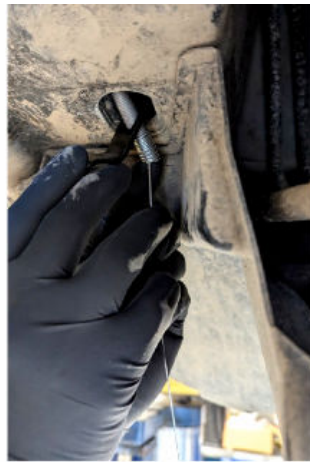

Keep one hand on the guide wire while using the other hand to push the frame insert washer through the drain hole.

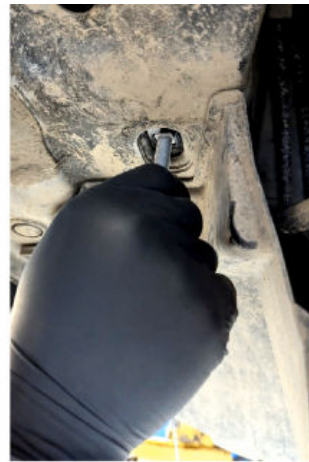

Align the squares of the bolt and the frame insert washer. (Keep bolt guide connected to the bolt.)

3. Line up the brace.

WHEEL WELL VIEW



FRONT ←



Bolt guide wire and bolt will be seen here.

4. Loosely install the rear trailing arm front mounting bolt (do not torque to spec).

FRONT ←



**REAR TRAILING ARM
FRONT MOUNTING BOLT**
Do not torque to specification.

5. From the underside, remove the bolt guide wire and hand-tighten the **10mm** nut. Use a downward force on the bolt (10x62) until it is loosely tightened.



6. Before tightening the underbody bolts, make sure that the brace is sitting flush against the wheel well in both directions as shown below.



7. Once the brace is positioned against the wheel well, torque the rear trailing arm front mounting bolt to **115 N·m (85 lb-ft)** first, then torque the rear brace bolt to **38 N·m (28 lb-ft)**.



8. From the wheel well side, place the drill guide into one of the brace openings and use the **3/8 bit** to drill into the wheel-well body. Drill both holes.
 - Use a vacuum to remove any metal shavings.
 - Apply touch-up paint around both drilled holes to prevent any new corrosion to the body.

DRILL GUIDE



9. Align the support bracket with the two bolts from the brace and place into the body. Then install the two **8mm nuts**, and torque them to **21 N.m (15.5 lb-ft)**.



Align bracket with flange facing towards the front of the vehicle, over the two brace studs, then install the two bracket bolts.



8 mm NUTS
21 N·m (15.5 lb-ft)
Tighten.

10. Repeat steps 1 through 9 on the opposite side of the vehicle.
 11. Install the tires and lower the vehicle.
- END