



GROUP	MODEL
Safety Recall Campaign	2015-2019MY Soul EV (PS EV)
NUMBER	DATE
SC267 (Rev 5, 03/04/2026)	August 2023

SAFETY RECALL CAMPAIGN

HIGH-VOLTAGE BATTERY PACK AND BATTERY MANAGEMENT SYSTEM (SC267)

NOTICE

This bulletin has been revised to include additional information. New/revised sections of this bulletin are indicated by a black bar in the margin area.

This bulletin provides information regarding High-Voltage Battery Pack and Battery Management System (BMS) for the subject vehicles below. An electrical short circuit between the anode and cathode of the battery cells can occur within the high-voltage battery pack assembly (BPA) case located underneath the vehicle. If an electrical short circuit occurs, a fire may result while driving, thereby increasing the risk of injury.

For the affected 2015-2017 MY SOUL EV vehicles manufactured from July 15, 2014 through June 30, 2017 that had their high-voltage battery replaced under warranty with an E400 battery (P/N: 37510-E4200/E4200R/E4250/E4250R), dealers are to:

- 1) First, replace the BMS and the Voltage & Temperature Sensor Wiring Harness (VTSWH),
- 2) Update the BMS with new software in 'Manual Mode' only, and
- 3) Inspect the High-Voltage Battery and, in necessary, replace it with a new one.

For all 2018-2019 MY SOUL EV vehicles manufactured from July 3, 2017 through September 28, 2018 equipped with an E400 high-voltage battery, dealers are to:

- 1) Update the BMS with new software, and
- 2) Inspect the High-Voltage Battery and, if necessary, replace it with a new one

Before conducting the procedure, verify that the vehicle is included in the list of affected VINs.

NOTICE

There is no charge to the vehicle owner for this repair. Under applicable law, you may not sell or otherwise deliver any affected vehicle until it has been repaired pursuant to the procedures set forth in this bulletin.

Repair status for a VIN is provided on KDealer+ (Service → Warranty Coverage → Warranty Coverage Inquiry → Campaign Information). Not completed Recall / Service Action reports are available on KDealer+ (Consumer Affairs → Not Completed Recall → Recall VIN → Select Report), which includes a list of affected vehicles.

This issue number is SC267.

A printed copy is for reference only; publication information can be updated at any time. Always refer to KGIS for the latest information. After logging in kdealer.com, the newest technical publications are listed in 'Service Releases' and has the latest service information that has been released.
Kia America, Inc. Confidential

Flowchart and Revision Summary:

- Revision 2:** 'BPA Label Inspection' is no longer required and steps were removed from this publication.
- Revision 3:** Correction to page reference on page 5, step 3.
- Revision 4:** New BPA PN for 15-17MY has 'new' type harness pre-installed. New SW ROM ID updated.
- Revision 5:** New BPA PN for all MY's.

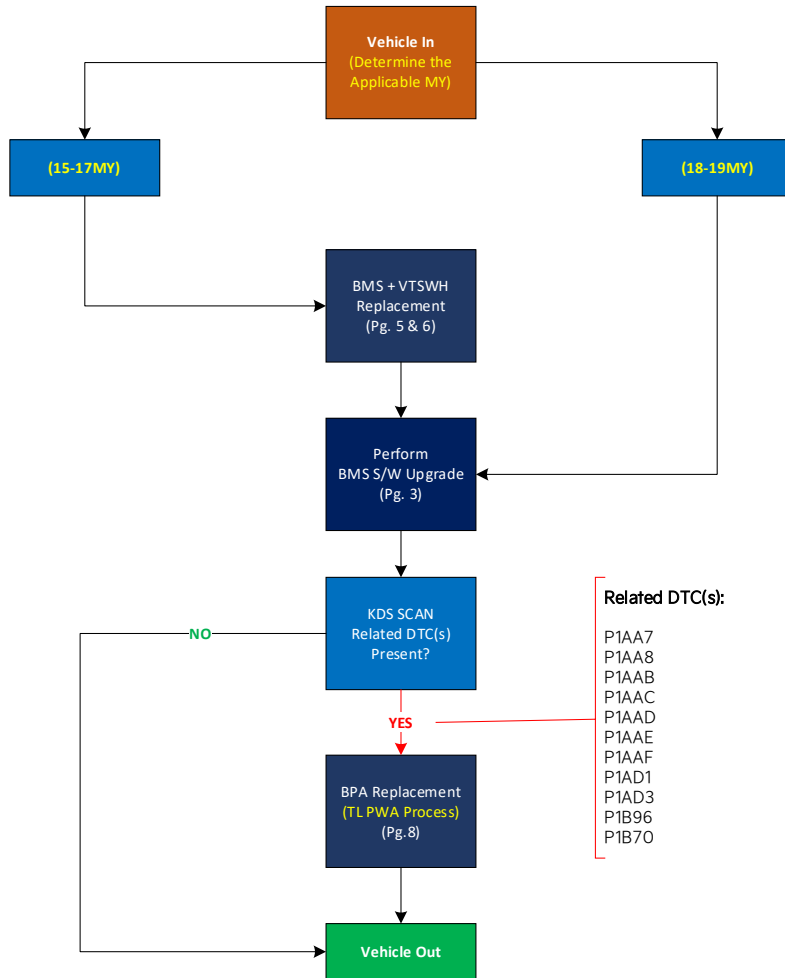

NOTICE

TL PWA is required for HV BPA replacement. Dealer should follow the process included in TSB [ELE044](#) and obtain TL PWA. Claim submission concerns WILL occur if the dealer does not obtain TL PWA for HV BPA replacement.

Operation Descriptions:

- BMS Software (BMS S/W)
- High Voltage Battery Pack Assembly (HV BPA)
- Voltage & Temperature Sensor Wiring Harness (VTSWH)
- Battery Management System (BMS)

Note: For 15-17MY only, the two (2) VTSWH previously installed on the existing HV BPA DO NOT need to be swapped if a 'new' HV BPA replacement is performed.



SUBJECT:

HV BATTERY PACK AND BATTERY MANAGEMENT SYSTEM (SC267)

ECU Upgrade Procedure:

To correct this condition, the ECU should be reprogrammed using the KDS download, as described in TSB [SST081](#).

Upgrade Event Name
*728. 15-17MY PS EV BMS Diagnostic Logic Enhancement Touch - 3 rd
729. 18-19MY PS EV BMS Diagnostic Logic Enhancement Touch - 3 rd

Note: Event #728 for 15-17MY PS EV will not appear in the upgrade events list as it needs to be performed in 'Manual Mode' only after BMS replacement.

 NOTICE

- Confirm a **fully charged battery** (12.3 volts or higher is necessary) is used or utilize a fully charged jump starter box connected to the battery.
- **Ensure the KDS GDS is sufficiently charged at 60% or higher prior to reflash.**
- All ECU upgrades must be performed with the ignition set to the 'ON' position unless otherwise stated.
- **Damaged VCI II units should not be used and promptly replaced.**
- Be careful not to disconnect the VCI-II connected to the vehicle during the ECU upgrade procedure.
- **DO NOT start the engine during ECU upgrade.**
- DO NOT turn the ignition key 'OFF' or interrupt the power supply during ECU upgrade.
- **When the ECU upgrade is completed, turn the ignition 'OFF' and wait 10 seconds before starting the engine.**
- ONLY use approved ECU upgrade software designated for the correct application.

 IMPORTANT

It is recommended to ALWAYS check the Electronic Parts Catalog (EPC) to locate the ECU Part Number respective to Auto/Manual Mode ROM IDs. DO NOT reference the parts label affixed to the ECU.

 NOTICE

If a 'Communication Fail' error notice appears or the upgrade cannot be performed, DO NOT disconnect the KDS/VCI-II. Contact GIT America Help Desk at (888) 542-4371 or Techline.

 NOTICE

Before attempting an ECU upgrade on any Kia model, make sure to first determine whether the applicable model is equipped with an immobilizer  (IMMO) security system. Failure to follow proper procedures may cause the PCM to become inoperative after the upgrade and any claims associated with this repair may be subject to chargeback.



ROM ID INFORMATION TABLE:

Upgrade Event #728 (15-17MY) or #729 (18-19MY)

Model	SYSTEM	IMMO		ECU P/No.	ROM ID		
					Previous	New	
PS EV 18-19MY	BMS	Yes		37513 E4350	4400	4700	4940
					4500	4800	
37513 E4300				4600	4900/20		
				4402	4702	4942	
37513 E4251	4502	4802					
	4602	4902/22					
PS EV 15-17MY*				37513 E4251	4604	4804	4944*
					4704	4904/24	
37513 E4201				4606	4806	4946*	
				4706	4906/26		

Note: *Perform Event #728 in 'Manual Mode' only for 15-17MY model.

To verify the vehicle is affected, be sure to check the Calibration Identification of the vehicle's ECM ROM ID and reference the Information Table as necessary.

Refer to [TSB SST081](#) for instructions to upgrade the 'BMS' system:

UPGRADE EVENT:

EVENT #728 (15-17MY) or #729 (18-19MY)

Note: Event #728 for 15-17MY PS EV will not appear in the upgrade events list as it needs to be performed in 'Manual Mode' only.

Confirm if 'Heated' or 'Non-Heated' type.

NOTICE

Prior to performing the ECU upgrade, be sure to check that the KDS is fully charged.

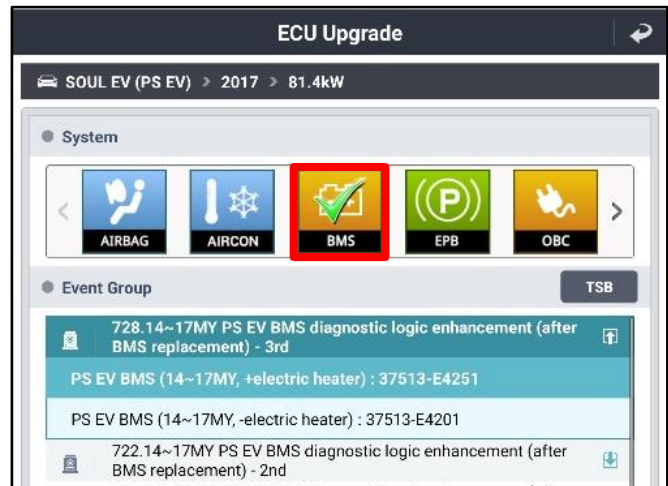

Manual Mode ECU Upgrade Passwords

Menu	Password
PS EV BMS (15~17MY, +electric heater): 37513-E4251	4251
PS EV BMS (15~17MY, -electric heater): 37513-E4201	4201
PS EV BMS (18~19MY, +electric heater): 37513-E4350	4350
PS EV BMS (18~19MY, -electric heater): 37513-E4300	4300

Note: *Perform Event #728 in 'Manual Mode' only for 15-17MY model.



SUBJECT:

HV BATTERY PACK AND BATTERY MANAGEMENT SYSTEM (SC267)

WARNING

Be sure to read and follow the 'General Safety Information and Caution', the 'High Voltage Shut-Off Procedures' and 'High Voltage Battery Handling Guide' instructions outlined on KGIS before doing any work related with the high voltage system. Failure to follow the safety instructions may result in serious electrical injuries.

BMS ECU Replacement Procedure: (15-17MY Only)

1. Remove the BPA upper case (A) by referring to "EV Battery System → High Voltage Battery System → Case → Repair procedures (Removal)" in the applicable Shop Manual on KGIS. Refer to KGIS for bolt/nut torque specs.

**TECH TIP**

Mark the six (6) 'ground' bolts and their location to prevent mixing with regular bolt prior to reassembly.

Regular Bolt (8)



Ground Bolt (E)



Ground Bolt (E): 6 ea.

Regular Bolt (8): 35 ea.

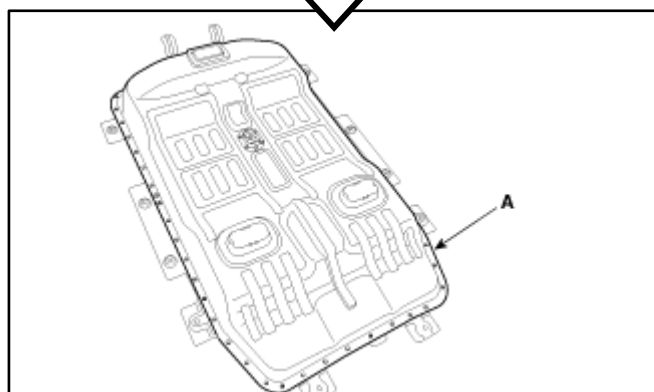

2. Replace the BMS ECU by referring to "EV Battery System → High Voltage Battery Control System → Battery Management System (BMS) ECU → Repair procedures (Removal)" in the applicable Shop Manual on KGIS.
3. Proceed to page 10 to replace the Voltage & Temperature Sensor Wiring Harness (VTSWH).



VTSWH Replacement Procedure: (15-17MY Only)

1. Carefully remove ONLY ONE (1) (left or right) side battery pack assemblies.

Refer to the “EV Battery System → High Voltage Battery System → Battery Pack Assembly → Repair procedures (Removal)” in the applicable Shop Manual on KGIS for detailed instructions.

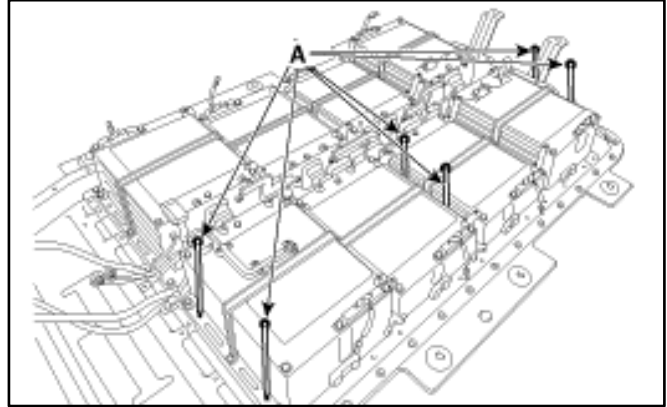

Note: SST OK375 E4300 and crane jack are required.

2. Place the battery on a clean and flat bench surface area.

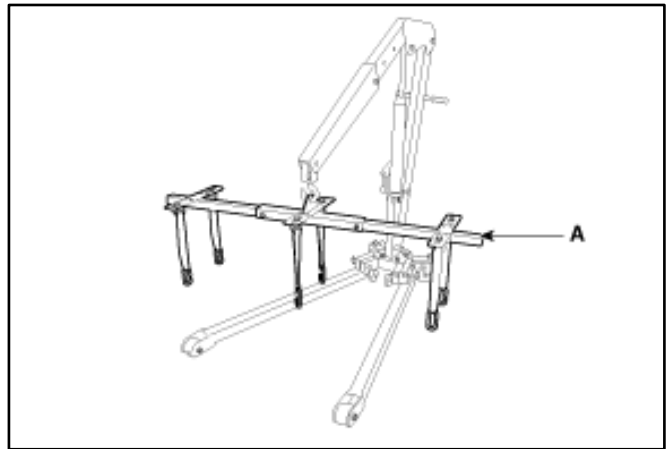

3. Remove the existing voltage and temperature sensor wiring harness (VTSWH) retaining screws for both (left and right) battery packs.



SUBJECT:

HV BATTERY PACK AND BATTERY MANAGEMENT SYSTEM (SC267)

- Replace the two voltage temperature sensor wire harnesses (VTSWH) with the new parts.

Note: The new harness is different for the removed harness when compared side by side.

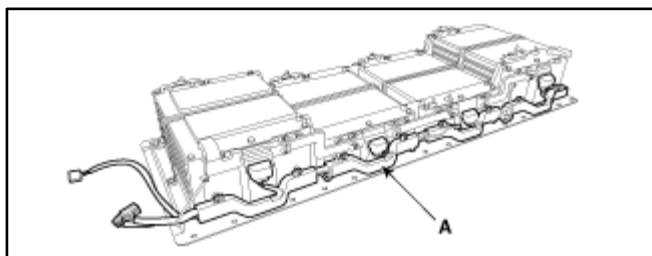
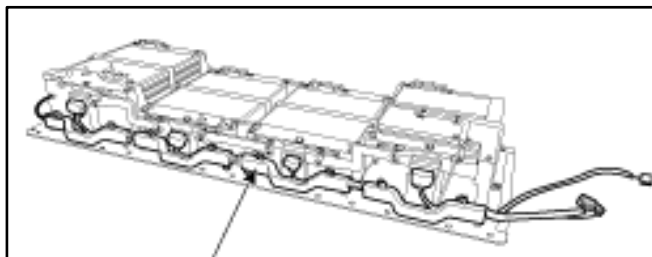
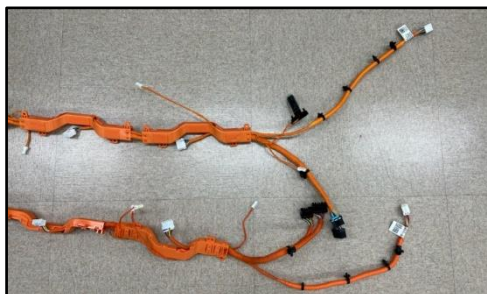

- During re-assembly, insert the battery temperature sensor into the battery pack lower side area shown.

Connect the outside temperature sensor connector where shown.

Note: Some vehicles may have a remaining temperature sensor connector hole. If so, disregard, no need to connect to it.

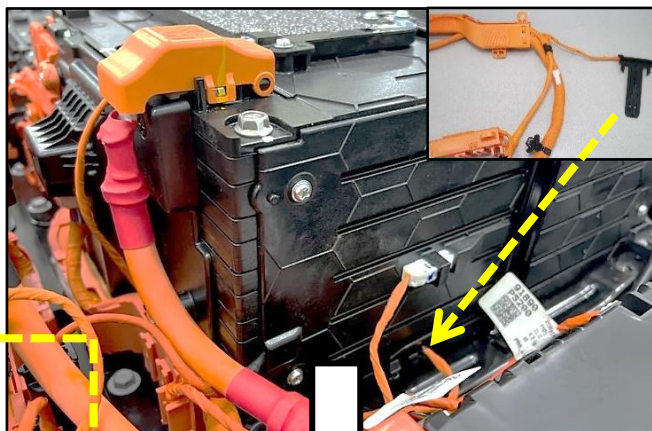

- Reinstall all removed parts in the reverse order of removal.
- Perform the BCM Software Upgrade as outlined on page 3.
- Confirm normal vehicle operation.
- Using KDS, scan for related DTC described on page 2. Are related DTC(s) present?

- YES (NG)** - Related DTC(s) are stored. Replace the BPA Assembly (Page 12)
- NO (OK)** - No DTC(s) or Non-Related DTC(s) stored. Campaign is complete.

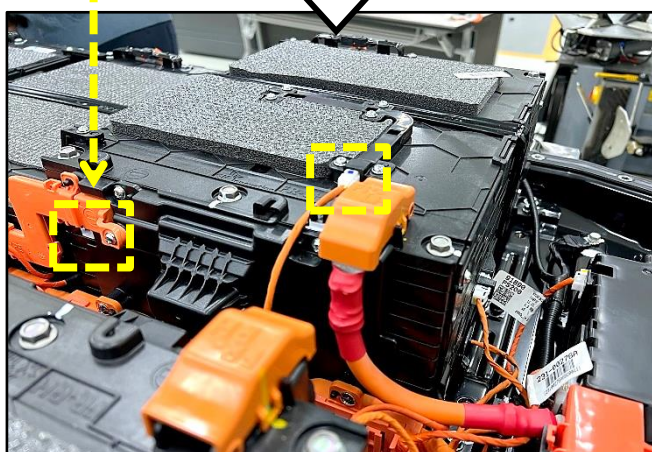

⚠ WARNING

Be sure to read and follow the 'General Safety Information and Caution', the 'High Voltage Shut-Off Procedures' and 'High Voltage Battery Handling Guide' instructions outlined on KGIS before doing any work related with the high voltage system. Failure to follow the safety instructions may result in serious electrical injuries.

BPA Replacement Procedure: (15-19MY if applicable)

1. Replace the HV BPA by referring to "EV Battery System → High Voltage Battery System → Battery Pack Assembly → Repair procedures (Removal)" in the applicable Shop Manual on KGIS.

Note: Dealer must obtain TL PWA.

ⓘ IMPORTANT

15-17MY ONLY new PN BPA is equipped with a "new" type harness. **(Rev 4) removed swap harness.**



Note: SST OK375 E4300 BPA lifting jig and crane jack (A) are required.

📄 NOTICE

Place the removed BPA on a clean flat surface. Dealer should follow the process included in TSB ELE044 and obtain TL PWA.

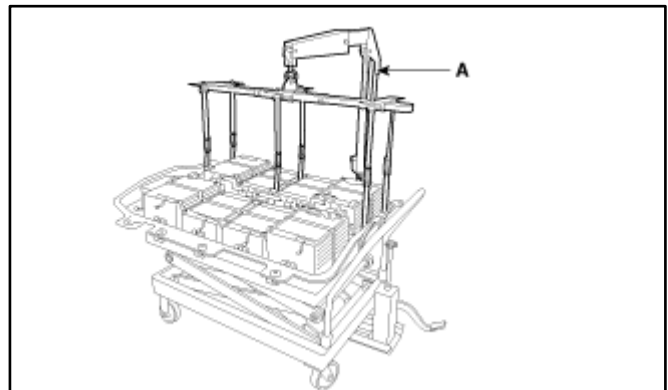

Note: The battery pack assembly (BPA) consists of two (2) (left and right) battery packs.

ⓘ IMPORTANT

18-19MY ONLY new BPA is equipped with the "new" type harness. There is no need to swap.

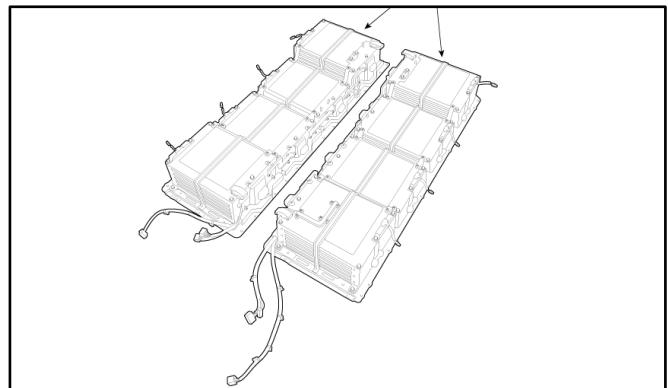

SUBJECT:



HV BATTERY PACK AND BATTERY MANAGEMENT SYSTEM (SC267)**AFFECTED VEHICLE RANGE:**

Model	Production Date Range
15-17MY Soul EV (PS EV)	July 15, 2014 to June 30, 2017
18-19MY Soul EV (PS EV)	July 3, 2017 to September 28, 2018

REQUIRED TOOL:

Tool Name	Part Number	Figure	Comments
BPA Lifting Jig	OK375 E4300		To Be Used Along With an Engine Crane/Hoist.

REQUIRED PART:

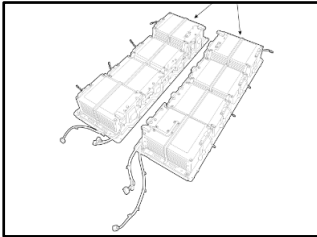
Part Name	Part Number	Figure	Qty.	Comment
Volt. & Temp. Sensor Wire Harness (VTSWH) <i>(New for 15-17MY only)</i>	37561 E4210QQK		1	Left Side
	37561 E4220QQK		1	Right Side
Battery Management System (BMS) <i>(15-17MY only)</i>	37513 E4201QQK		1	Non-Heated
	37513 E4251QQK			Heated
HV Battery Pack Assembly (BPA)* (15-17MY) <i>(Rev4: BPA has been updated with a 'new' VTSWH)</i>	37510 E4203QQK*		1	Non-heated
	37510 E4253QQK*			Heated
HV Battery Pack Assembly (BPA) (18-19MY)	37510 E4302QQK*		1	Non-heated
	37510 E4352QQK*			Heated

***Note:** If replacement of the BPA for 15-17MY is required after already having installed the two (2) new VTSWH and BMS, then the 'new' BPA (left and right-side battery packs) WILL NOT require the previously installed VTSWH on the existing BPA to be installed/swapped onto the 'new' BPA. ***Note:** You may receive a BPA with a part number ending in "QQKR" when a part ending in "QQK" was ordered. Both part numbers are interchangeable and acceptable in the warranty claim. **Be sure to use the corresponding Op Code for the BPA PN received.**

IMPORTANT: The parts listed below DO NOT require replacement unless damaged or lost during removal.

Case Gasket (15-19MY)	37528 E4000QQK	N/A	1	Replace <u>only</u> if damaged
Bolt & Washer for BPA	11408 06166PQQK	N/A	1	3pc. Included per pack are needed.
Nut for VTSWH	37535 E4500QQK	N/A	1	



SUBJECT:

HV BATTERY PACK AND BATTERY MANAGEMENT SYSTEM (SC267)

WARRANTY INFORMATION: (PN ENDING IN "QQKR")

N Code: N99 C Code: C99

MY	Claim Type	Causal P/N	Qty.	Repair Description	Labor Op Code	Op Time	Replacement P/N	Qty.	
15-17MY	R	37510 E4000	0	(SC267) BMS & VTSWH Replacement + 'New' BMS SW Upgrade (Event #728) + KDS DTC Scan (OK)	231055R5	2.5 M/H	37561 E4210QQK	1	
							37561 E4220QQK		
							37528 E4000QQK		
							37513 E4201QQK or 37513 E4251QQK		
							11408 06166PQQK		
							37535 E4500QQK		
15-17MY	R	37510 E4000	0	(SC267) BMS & VTSWH Replacement + 'New' BMS SW Upgrade (Event #728) + KDS DTC Scan (NG) + 'New' BPA Replacement (PN E4203QQKR or E4253QQKR)	231055R6	5.3 M/H	37561 E4210QQK	1	
							37561 E4220QQK		
							37528 E4000QQK		
							37513 E4201QQK or 37513 E4251QQK		
							11408 06166PQQK		
							37535 E4500QQK		
18-19MY	R	37510 E4000	0	(SC267) 'New' BMS SW Upgrade + (Event #729) KDS DTC Scan (OK)	231055R7	0.3 M/H	N/A	0	
				(SC267) 'New' BMS SW Upgrade (Event #729) + KDS DTC Scan (NG) + 'New' BPA Replacement (E4302QQKR or E4352QQKR)	231055R8	3.0 M/H	37528 E4000QQK	1	
							37510 E4302QQKR or 37510 E4352QQKR		
							11408 06166PQQK		

Note: Refer to [Warranty Bulletin 2023-24](#) for claim submission procedures. When substitute transportation is provided, manually enter sublet code 'X2' for rental expense reimbursement or one roundtrip rideshare expense.



SUBJECT:

HV BATTERY PACK AND BATTERY MANAGEMENT SYSTEM (SC267)

WARRANTY INFORMATION: (PN ENDING IN "QQK")

N Code: N99 C Code: C99

MY	Claim Type	Causal P/N	Qty.	Repair Description	Labor Op Code	Op Time	Replacement P/N	Qty.	
15-17MY	R	37510 E4000	0	(SC267) BMS & VTSWH Replacement + 'New' BMS SW Upgrade (Event #728) + KDS DTC Scan (OK)	231055R5	2.5 M/H	37561 E4210QQK	1	
							37561 E4220QQK		
							37528 E4000QQK		
							37513 E4201QQK or 37513 E4251QQK		
							11408 06166PQQK		
							37535 E4500 QQK		
15-17MY	R	37510 E4000	0	(SC267) BMS & VTSWH Replacement + 'New' BMS SW Upgrade (Event #728) + KDS DTC Scan (NG) + 'New' BPA Replacement (PN E4203QQK or E4253QQK)	231055R9	5.3 M/H	37561 E4210QQK	1	
							37561 E4220QQK		
							37528 E4000QQK		
							37513 E4201QQK or 37513 E4251QQK		
							11408 06166PQQK		
							37535 E4500QQK		
							37510 E4203QQK or 37510 E4253QQK		
18-19MY	R	37510 E4000	0	(SC267) 'New' BMS SW Upgrade + (Event #729) KDS DTC Scan (OK)	231055R7	0.3 M/H	N/A	0	
				(SC267) 'New' BMS SW Upgrade (Event #729) + KDS DTC Scan (NG) + 'New' BPA Replacement (E4302QQK or E4352QQK)	231055RA	3.0 M/H	37528 E4000QQK	1	
							37510 E4302QQK or 37510 E4352QQK		
							11408 06166PQQK		

Note: Refer to [Warranty Bulletin 2023-24](#) for claim submission procedures. When substitute transportation is provided, manually enter sublet code 'X2' for rental expense reimbursement or one roundtrip rideshare expense.

