



INFINITI

VOLUNTARY RECALL CAMPAIGN

Classification: KS23-001A	Reference: ITB23-013A	Date: April 18, 2023
------------------------------	--------------------------	-------------------------

VOLUNTARY SAFETY RECALL CAMPAIGN 2022 QX50 AND 2023 QX55; RIGHT FRONT DOOR LOCK

This bulletin has been amended. See AMENDMENT HISTORY on the last page.
Please discard previous versions of this bulletin.

CAMPAIGN ID #: PC962
APPLIED VEHICLES: 2022 QX50 (J55)
2023 QX55 (FJ55)

**Check Service COMM or Dealer Business Systems (DBS)
National Service History to confirm campaign eligibility.**

INTRODUCTION

Infiniti is conducting this voluntary safety recall campaign on certain specific model year 2022 QX50 and 2023 QX55 vehicles to replace the passenger (RH) Front Door Lock. This service will be performed at no charge to the client for parts or labor.

IDENTIFICATION NUMBER

Infiniti has assigned identification number PC962 to this campaign. This number must appear on all communication and documentation of any nature dealing with this campaign.

DEALER RESPONSIBILITY

It is the retailer's responsibility to check Service COMM or Dealer Business Systems (DBS) National Service History for the campaign status on each vehicle falling within the range of this voluntary safety recall which for any reason enters the service department. This includes vehicles purchased from private parties or presented by transient (tourist) clients and vehicles in a retailer's inventory. **Federal law requires that new vehicles in retailer inventory which are the subject of a safety recall must be corrected prior to sale. Failure to do so can result in civil penalties by the National Highway Traffic Safety Administration.** While federal law applies only to new vehicles, Infiniti strongly encourages retailers to correct any used vehicles in their inventory before they are retailed.

Bulletins are intended for use by qualified technicians, not 'do-it-yourselfers'. Qualified technicians are properly trained individuals who have the equipment, tools, safety instruction, and know-how to do a job properly and safely. **NOTE:** If you believe that a described condition may apply to a particular vehicle, DO NOT assume that it does. See your Infiniti retailer to determine if this applies to your vehicle.

SERVICE PROCEDURE

1. Replace the passenger (RH) Front Door Lock.
 - Refer to the ESM: **BODY EXTERIOR, DOORS, ROOF & VEHICLE SECURITY > DOOR & LOCK > REMOVAL AND INSTALLATION > FRONT DOOR LOCK > DOOR LOCK**

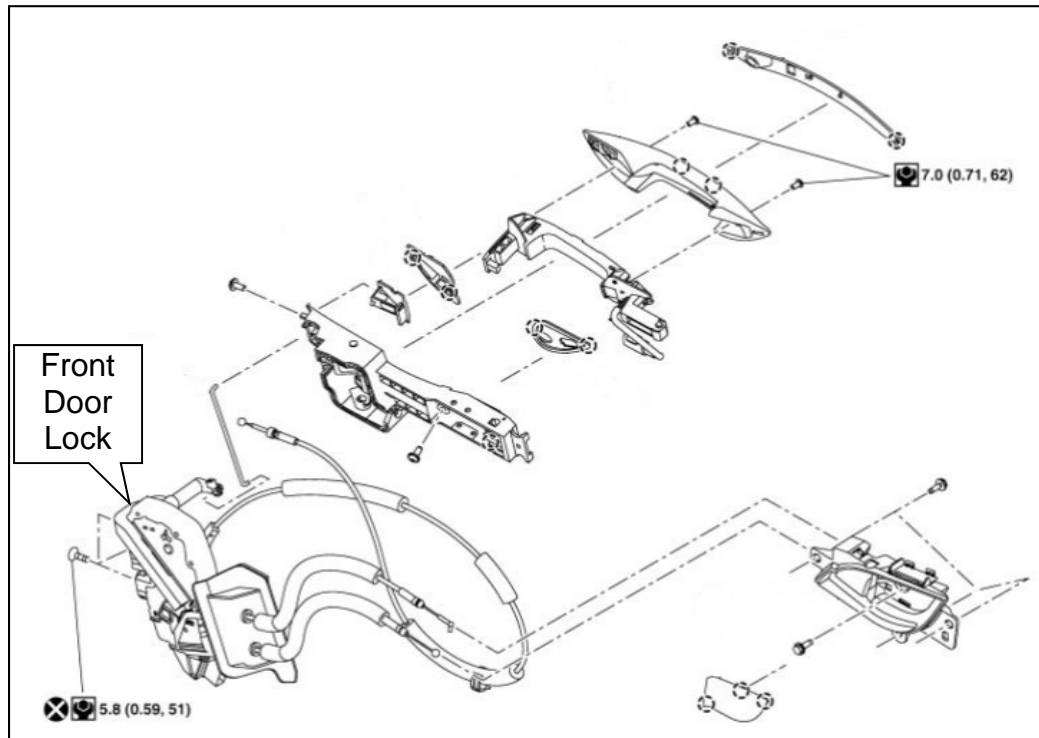

Figure 1

PARTS INFORMATION

DESCRIPTION	PART NUMBER	QUANTITY
LOCK & REMOTE CONTROL ASSY-FRONT DOOR, RH	80500-9CM0A	1
SCREW	80599-4AF0A	3

CLAIMS INFORMATION

Submit a "CM" line claim using the following claims coding:

CAMPAIGN ("CM") ID	DESCRIPTION	OP CODE	FRT
PC962	Replace Right Front Door Lock	PC9620	0.7

AMENDMENT HISTORY

PUBLISHED DATE	REFERENCE	DESCRIPTION
March 20, 2023	ITB23-013	Original bulletin published
April 18, 2023	ITB23-013A	PARTS INFORMATION revised

