



# INSTRUCTION TO SERVICE

ITS: 60731		5/30/2023
<b>SECTION:</b>	260-Battery Compartment	
<b>WRITTEN BY:</b>	Michel d'Auteuil	
<b>SUBJECT:</b>	Install 4 drains into each ESS compartment – 6 String ESS	
<b>ISSUE:</b>	Should a leak occur, liquids can accumulate in the ESS compartment	
<b>SUMMARY:</b>	Install 4 drains into each of the 6 ESS compartments	

# ITS60731

Ref. NHTSA Recall No.	Ref. Transport Canada Recall No.
23V083000	2023-073

**THIS ITS DOCUMENT SHOULD BE RETAINED AND REFERRED TO FOR FUTURE MAINTENANCE UNTIL THE NEW FLYER PARTS AND/OR SERVICE MANUAL IS UPDATED TO REFLECT WORK DONE AS A RESULT OF THIS DOCUMENT. ENSURE THAT THIS DOCUMENT IS AVAILABLE FOR PARTS AND MAINTENANCE STAFF GOING FORWARD.**

## PROCEDURE:

### Section 1 – Initial Prep Work

1. Set the park brake and chock the wheels.
2. Turn the main battery disconnect and HV interlock switch to the “OFF” position.

**⚠ WARNING: The work detailed in this ITS involves working near exposed High Voltage (HV) compartments, even after the bus has been locked out and tagged out. It is recommended that the service personnel be trained in NFI HV safety practices, such as those included in Appendix A – NFIL Spec 532295 - High Voltage Safety Guidelines & Procedures for New Flyer Battery Bus.**

3. Perform the Lock Out Tag Out and De-Energizing procedures found in the Electrical System Section of the New Flyer Service Manual. Reference Figure 1 below.

**⚠ WARNING: ENSURE MSD DUMMY PLUGS AND ARC FLASH GLOVES ARE AVAILABLE PRIOR TO STARTING ANY HV DISASSEMBLY**

**🔧 NOTE: Use commercially available lock out equipment and tags being sure to follow any local laws or workplace procedures.**

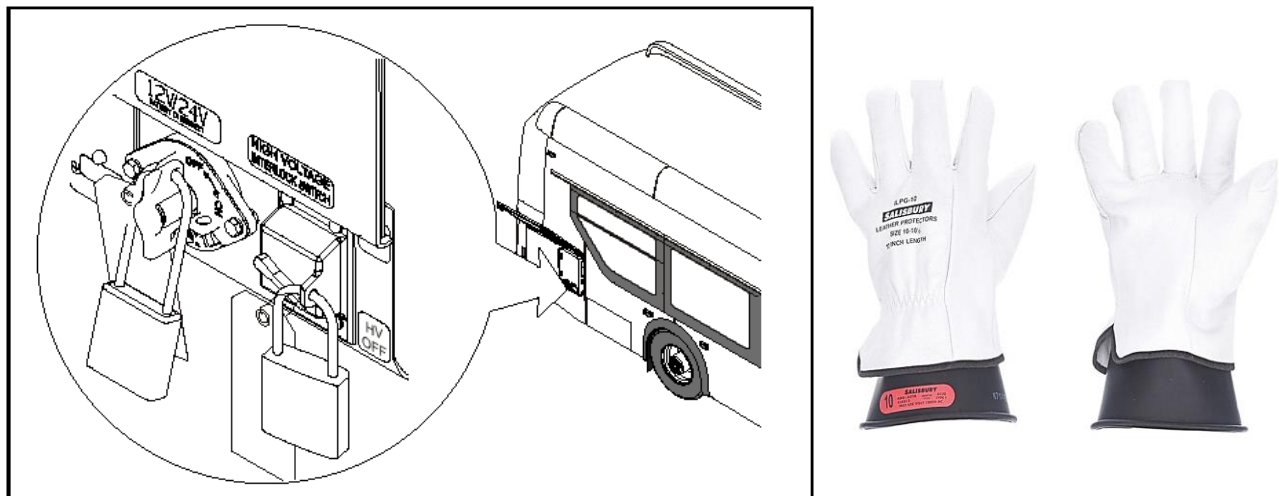

**Section 2 – ESS Access**

- Gain access to the rooftop ESS enclosures. Ensure that appropriate fall protection PPE is used and available for the duration of the work. Reference Figure 2 below for the upper ESS layout.

**Ensure appropriate safety procedures are followed for the duration of the work.**



**Figure 2: Upper ESS Layout**

- Open the rear access door to expose the drain ports (some components removed for clarity). You will need special torque tools to access the ports on the rear ESS.

**NOTE: At this point access to the ESS compartments is available.**

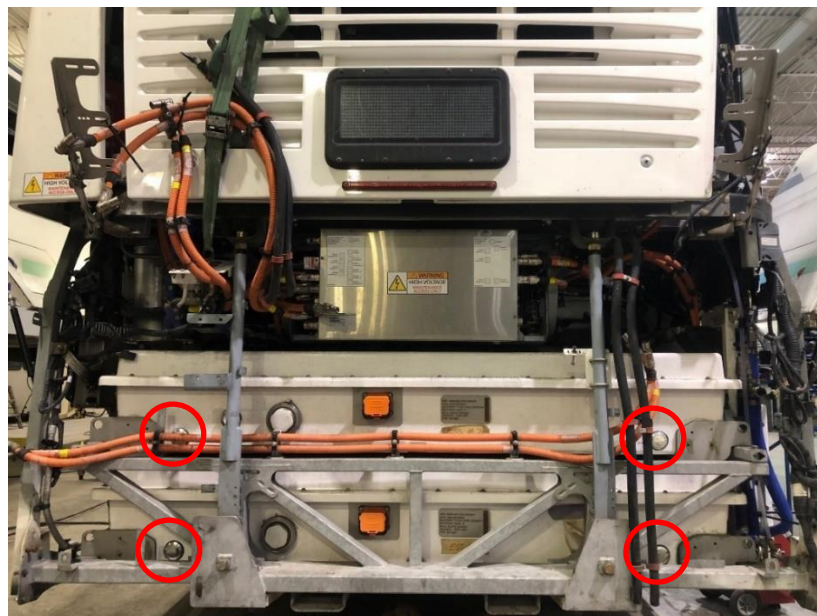

**Figure 3: Rear ESS Layout and rear drain locations**

**Section 3 – Drain Installation**

6. Remove plugs from the ESS and immediately install an ESS drain cartridge assembly PN 1025289. Torque to 40 ft-lbs. Repeat for all 24 drains.

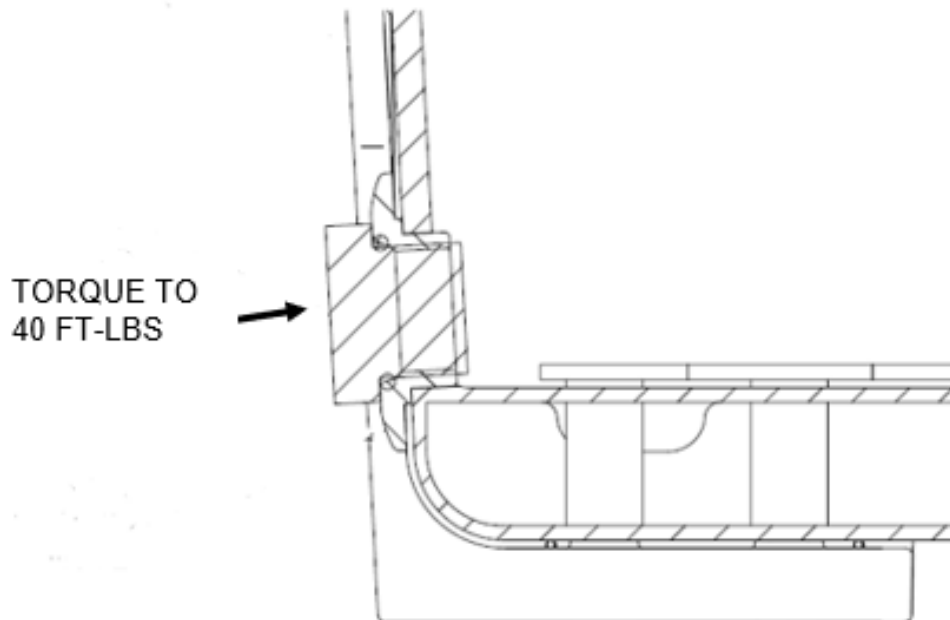
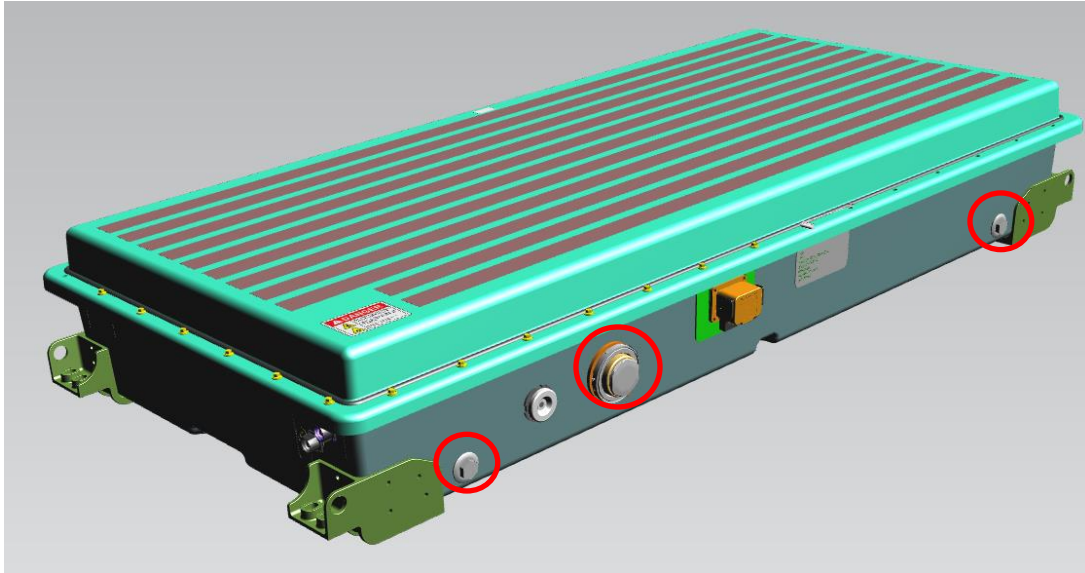

**Figure 4: Drain Locations (four per ESS) – USE ARC FLASH GLOVES**

7. Add 3 supplied **desiccant bags (PN 6492726)** to the desiccant holder. The desiccant bags must not be left exposed to air longer than necessary. Reference **Error! Reference source not found.** for details.

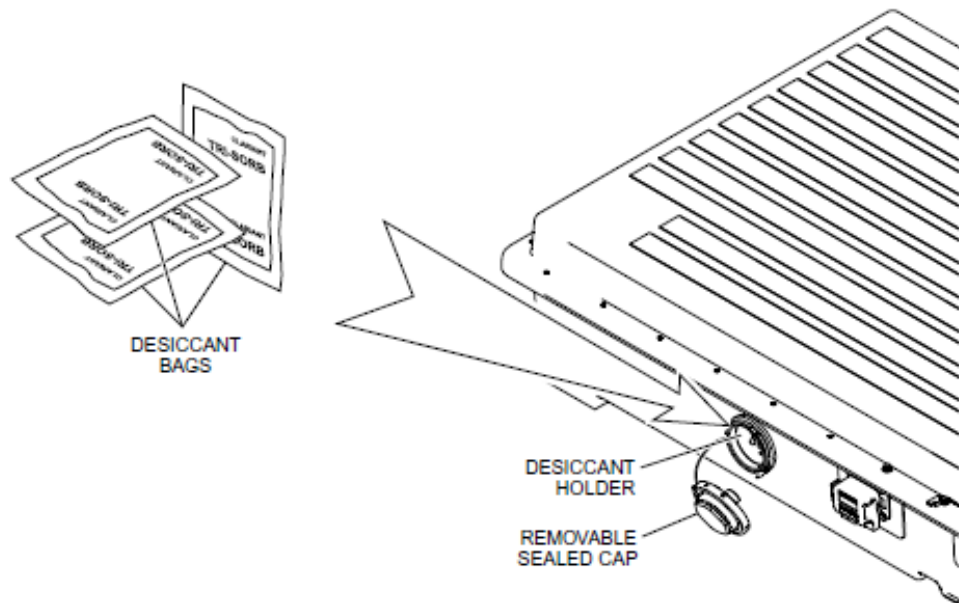

**Figure 5: Desiccant Basket Location – USE ARC FLASH GLOVES**

8. Clean workspace and return coach to revenue service condition.

<b>LABOUR – 6 STRINGS</b>				
	Operation	Number of Technician(s)	Hours	Labor Time T X HR
1	INSTALL 24 ESS DRAINS 5-STRING	1	2	2

<b>PARTS KIT – 6 STRINGS</b>					
Item	Part Number	Description	Qty. per Coach	Units	Notes
1	6492726	POUCH-DESICCANT SINGLE BAGGED	18	EA	ITS Parts
2	1025289	ASSY – DRAIN CARTRIDGE	24	EA	

<b>TOOL KIT</b>					
Item	Part Number	Description	Qty.	Units	Notes
1	6495077	TOOL-15 DEGREE OFFSET BOX END	1	EA	Part of Tool Kit
2	6495078	TOOL-1/4 DRIVE RATCHET	1	EA	
3	6495079	TOOL-40FT LBS PRESET TORQUE WRENCH	1	EA	

## **Appendix A – NFIL Spec 532295 - High Voltage Safety Guidelines & Procedures for New Flyer Battery Bus**

The following provides general guidelines in relation to safety and best practices when completing installation or servicing work on any New Flyer battery bus vehicle platform.

This document is not meant to supersede the actual released installation and assembly drawings and where conflicts arise, the released engineering drawings take precedence.



### **Introduction**

The utmost concern, while working with High Voltage (HV) systems, is the safety of yourself, other personnel, and the potential of damage to property. To minimize these risks, it is crucial to be properly trained and always maintain a very alert, questioning, and disciplined attitude without fail. As soon as your guard is lowered, then the potential of an accident is probable that can hurt or kill yourself or someone else and possibly damage property.

### **What is High Voltage (HV)?**

Any form of voltage that is greater than 50 volts if the person's skin at the electrical contact points is not compromised and not wet.



### **Equipment Required**

The following equipment shall be required:

Digital Multimeter (DMM), 1000-volt Category III, 600 volt Category IV,  
10Megohm impedance or greater with insulated case or rubber holster  
Clamp-on current probe, 1000-volt Category III, 600 volt Category IV  
High Pot Tester (Hi-Pot)

Phase rotation meter

Personal Protection Equipment (PPE) appropriate for 700volt DC & 230  
volt AC with Class 00 or higher HV gloves with compatible leather over  
gloves. Appropriate safety glasses as well as the face shield. The PPE  
shall also meet the required Arc Flash & Arc Blast requirements. Before  
use, inspect the PPE in accordance with this guideline.

Adequate lighting

HV insulated mat

Two fused HV clip leads 10 inches long

Safety barricade with warning lights & "Danger High Voltage" signs

Belt tool pouch (use only to carry small components up/down a ladder)

Torque Screwdriver set

Imperial torque nut driver set

Metric torque nut driver set

### **Equipment Calibration**

All test equipment must be within their calibration interval and recorded such with the respective serial numbers.

These records must be available to the Checker.





### Personnel Requirement

Only trained personnel shall supervise and perform High Voltage system testing, checkout, and troubleshooting. Two personnel (one called the Checker & the other called Monitor/Recorder) shall perform Checkout Procedures, together, to ensure safety of themselves, others nearby & for the protection of vehicle & property. Refresher training shall be provided to these personnel on a regular basis and when new systems are to be checked by them. The training of the personnel shall consist of:

- HV & low voltage basics, intermediate & advanced electricity
- HV & low voltage electrical systems of the vehicle
- Shop safety practices & procedures
- First aide including CPR & the use of the shop defibrillator
- How to release a victim that can't let go HV
- Quickest method of shutting down HV
- Firefighting and emergency procedures
- HV & arc flash safety
- Organized & tidy placement of equipment & tools allowing for unrestricted movement
- Operation of Hi-pot

To ensure effectiveness of training, exams of the trained material shall be required with a high passing mark of at least 80% and a retraining of the missed 20 % on a one-to-one basis.

### Checker Function

**(Caution:** The Checker must not have any health conditions that can be exacerbated when startled and must not have any electronic implants.)

- Directed by the Monitor/Recorder
- Performs all preparations & checks
- Wears PPE as specified by the Checkout Procedure
- Performs all restorations

### Vehicle Inspection

It is necessary that the vehicle to be checked out, first be visually inspected of all systems, workmanship and with special attention to ensuring there is no HV cable or equipment damage or chafing.



### **High Voltage Checkout Preparation**

- (1) The scope of the work must be accurately defined such as a Checkout Procedure that requires systematic steps with sign offs. Before a Checkout is performed, the Supervisor, Checker and Monitor/Recorder must conduct a briefing of what shall transpire, identify potential hazards, resist pressures of “is it done yet?”, anticipate problems and question possible events. If unexpected electrical hazard or fault occurs, during any time of the Checkout, it must be immediately reported to the supervisor. After the Checkout is completed, the same group should review the results and processes and make proposed modifications to the procedures if required.
- (2) Install Safety barricade with warning lights & signs indicating "Danger High Voltage" around the vehicle perimeter and ensure no personnel are within the fenced perimeter during the checkout procedure.
- (3) It shall always be the goal to check the systems as much as possible with all HV power OFF and Locked Out/Tagged Out and proven as de-energized by voltage measurement using the DMM. The functionality of the DMM must be proved before and after the verification of no HV present. Then, if possible, the HV systems should be challenged by trying to energize them while checking that no HV appears.
- (4) When it is necessary to perform tests of HV systems with the power ON, then the Working Live procedure must be followed.
- (5) The test personnel shall always rehearse the actions required in case of any possible accident scenarios.
- (6) Before beginning the Checkout Procedure, the test personnel shall remove all their jewelry (including pierced ones), watches and any electrically conductive objects on them.

### **PPE Requirements**

The PPE voltage class, Arc Flash and Arc Blast rating shall be compatible with the voltage and Arc Flash capability of the systems being tested. Appropriate leather glove protectors shall be worn over the HV rubber gloves.

### **PPE Care & Testing**

Rubber insulated PPE shall be periodically cleaned and tested in accordance with 29 CFR 1910.137 and the appropriate ANSI/ASTM standards. HV gloves, sleeves and mats shall be tested every 6 months. PPE apparel shall be cleaned and maintained in accordance with the manufacturer’s instructions. A record of the PPE testing shall be maintained and available to the users.

### **PPE Inspection**

Inspect PPE equipment, before use, for any degradation or damage and ensure that the HV gloves have been tested every 6 months. Also perform an air pressure test on the HV gloves before and after each use. If during PPE use a potential damaging incident occurred to the PPE, stop further testing and inspect the PPE. If at any time the PPE is defective, reject it, and obtain an accepted one.

### **PPE Storage**

PPE apparel should be stored lying flat, undistorted, right-side out and not folded in protective containers. The HV mats can be rolled with an inside diameter greater than 2 inches.

Rubber HV gloves should be stored in cool, dark, dry, and free from damaging chemicals or vapors. The glove cuffs should face downwards, without folding, in the appropriate glove bag and hung vertically.

### **Insulated Tools**

Insulated tools should be visually inspected for insulation damage before and after each session of use.

### **Lockout/Tagout Procedure**

The Lockout/Tagout procedure should be followed that is specified in the respective checkout procedure. When removing the lock and tag:

- (1) The locks and tags shall be removed by the installer of them or under her/his supervision.
- (2) If the installer of the locks and tags is not available, then her/his supervisor:
  - (a) Ensures that the installer of the locks and tags is not in the facility
  - (b) Contacts the installer to inform her/him that the locks and tags will be removed
  - (c) Reminds the installer of the lock and tag removal when she/he resumes work

### **Stored Energy**

Personnel must always remember the characteristics of stored energy devices such as capacitors and batteries and when energy is available from.

### **Working Live**

To maximize safety, it is always important to perform the maximum amount of HV checkout in the de-energized state.

When it is necessary to work with HV equipment while energized or to verify whether HV is present, the utmost care and safety procedures must be utilized including:

- (1) Wearing appropriate PPE with protector gloves over top of the HV rubber gloves
- (2) Ensure all personnel, except the Checker and Monitor/Recorder, are clear of the vehicle
- (3) Kneeling or standing on HV insulated mat



### **Energizing & De-energizing Procedure**

It is critical that before any HV system is energized that a visual check be performed to ensure that all possible HV compartments are closed and there is no debris, tools or test equipment lying on HV terminations. If there is a certain sequence of energizing and de-energizing the HV system, then all personnel involved must be trained in this sequence. (CAUTION: Never try to connect or disconnect circuit components such as cables, fuses, connectors, etc. while there is current flowing in the circuit.)

### **Electrical Injuries**

Electrical injuries should be immediately reported to the first aide personnel and the supervisor. Other than electrostatic shocks, even non-injurious electrical shocks should be reported to the supervisor. These should be immediately investigated and documented to determine the cause and prevent the occurrence in the future.