



WARRANTY BULLETIN SAFETY CAMPAIGN

Can-Am® On-Road Spyder™

⚠️ WARNING: All involved customers must be notified, all involved units must be corrected as per instruction herein.

Campaign no.: 2022-0019

February 9, 2023 Subject: **Rearview Mirror Lenses May Dislodge - Decreased Visibility** No. **2022-19**

REVISION ▶ 1
March 16, 2023 ◀

▶ TEXT(S) BETWEEN ARROWS IS (ARE) MODIFIED ELEMENT(S) TO THE PREVIOUS PUBLICATION. ◀

IMPORTANT

What should you do?

- Do not sell or deliver any involved vehicle that you have in stock as federal law requires you to complete the recall service on these vehicles before retail delivery.
- Unregistered vehicles cannot be sold until the campaign is performed.
- Contact all of your customers who purchased an affected vehicle and inform them about this Safety Recall notice.

MODEL YEAR	MODEL	ADMISSIBLE UNITS
2022	Spyder F3 and F3-S	Go to BOSSWeb/Warranty/Campaign Monitoring to know the quantity of units in your inventory impacted by this campaign.

IMPORTANT

- When a vehicle comes in for service, always type the VIN in Knowledge Center to check for pending campaigns or alerts.
- When performing any work on a vehicle, it is good practice to connect it to BUDS2 to ensure that all needed updates are done.



PROBLEM

The rearview mirror lenses may dislodge from the housing. This can result in an increased risk of a crash due to the decreased visibility for the driver.

SOLUTION

Replace both mirror housing assemblies.

► REQUIRED PARTS ◀

NOTE: The parts for the repair will gradually be available starting April 1, 2023 and will be released progressively, upon availability, to ensure an even distribution across the network.

Vehicles with mirror housing assembly WITHOUT light integrated

DESCRIPTION	PART NUMBER	QTY
LH MIRROR ASS'Y (WITHOUT ARM)	219800555	1
RH MIRROR ASS'Y (WITHOUT ARM)	219800556	1

Vehicles with mirror housing assembly WITH light integrated

DESCRIPTION	PART NUMBER	QTY
LH REAR VIEW MIRROR HOUSING ASS'Y (Manufactured after January 10, 2023)	705015047	1
RH REAR VIEW MIRROR HOUSING ASS'Y (Manufactured after January 10, 2023)	705015048	1

► CORRECTIVE ACTION ◀

NOTE: The procedures are the same for LH and RH mirrors.

NOTE: The procedures are different for vehicles with light integrated.

Vehicles with mirror housing assembly WITHOUT light integrated

MIRROR ASSEMBLY REPLACEMENT

1. Remove and discard the mirror housing cap retaining screw.



2. Gently lift the mirror cap using a small Allen Key, then push the cap out of location as shown on picture to remove it from assembly. Discard the cap.



- Using a 3mm Allen Key, remove and discard the three (3) socket head screws and metal plate.



- Remove and discard the defective mirror assembly.
- Install new mirror assembly and secure in place using the three (3) new socket head screws and new plate from the kit.



NOTE: To ease installation, use a 3mm round head insert.

TIGHTENING TORQUE	
Mirror Assembly	1.0 N•m ± 0.2 N•m
Retaining Screw	(9 lbf•in ± 2 lbf•in)

- Install the new mirror housing cap. Place the ridge of the cap in the cavity and press the cap to hook it.



- Secure in place using the new retaining screw.



TIGHTENING TORQUE	
Mirror Cap Retaining Screw	2.5 N•m ± 0.5 N•m
	(22 lbf•in ± 4 lbf•in)

Vehicles with mirror housing assembly WITH light integrated

MIRROR HOUSING ASSEMBLY REPLACEMENT

1. Remove and discard the two housing retaining screws.

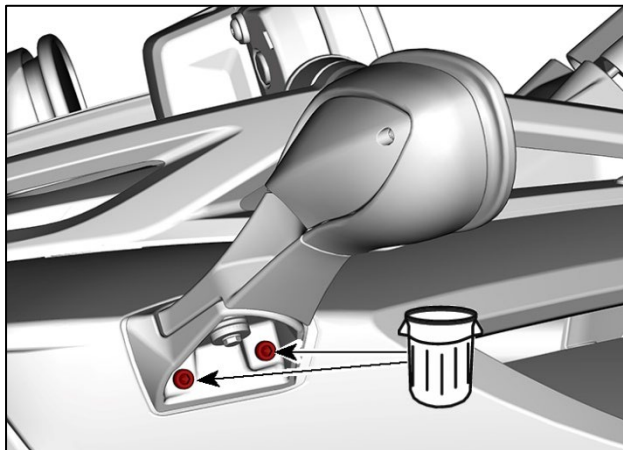

2. Gently pull the mirror housing and disconnect the mirror light harness connector.

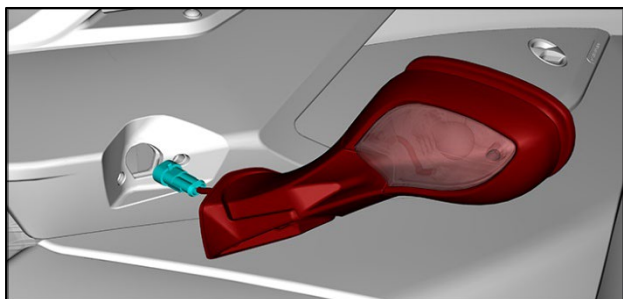

NOTE: If the connector is hard to reach, remove body panels to allow access to the connector.

3. Discard the mirror housing assemblies.
4. Clean threads on vehicle.
5. The installation is the reverse of the removal procedure.

NOTE: Connect the new mirror housing light connector and verify proper operation.

TIGHTENING TORQUE	
Mirror Housing Retaining Screw	3.5 N•m ± 0.5 N•m (31 lbf•in ± 4 lbf•in)

WARRANTY

Submit a warranty claim using the following information.

For claiming procedure, refer to the **online DEALER/DISTRIBUTOR WARRANTY GUIDE**.

Warranty Claim

With BOSSWeb

Product Line	Roadster
Unit Model Year	2022
Campaign/Bulletin/Description	19 / 2022-19 / MIRROR LENS MAY DISLODGE
*Action	
Inspect <input type="checkbox"/>	Repair <input checked="" type="checkbox"/>
Total Labor time paid	0.3 hour

With Warranty On Demand

CLAIM DETAILS	
Claim Type	Unit Campaign
Serial Number	Enter Serial Number
Warranty Campaign	Select 3WV-2022-0019 / MIRROR LENS MAY DISLODGE from drop-down list
Causal Part	705015049 or 705015050
Date of Repair	Repair date
Total Labor Time Paid	0.3 hour

INVENTORY VERIFICATION

NOTE: Verify inventory and include a picture of the manufacturing date code label.

Submit a warranty claim using the following information.

For claiming procedure, refer to the **online DEALER/DISTRIBUTOR WARRANTY GUIDE**.

Parts Claim

With BOSSWeb

CLAIM DETAILS	FROM INVENTORY
Repair Order Number	Enter repair order number
Product Line	On-Road
Authorization Number	-
Part Type	From inventory
Serial Number	-
Purchase Date	-
Accessory Failure Date	Today's date
Repair Completion Date	Today's date
Nature of Defect	Mirror Housing Assembly Disposal
Trouble Part Number	705015049 or 705015050
System Code	11
Job Number (The job number only becomes available when Dealer Installed is selected)	00
Trouble Code	X30
Part Required for Repair	705015049 or 705015050
Labor Only	-
Expiration Date	-

With Warranty On Demand

CLAIM DETAILS	FROM INVENTORY
Claim Type	Select Part from drop-down
Part Number	705015049 or 705015050
Installation Indicator	Over the counter
Date of Purchase	Today's date
Work Order Creation Date	Today's date
Date of Repair	Today's date
Causal Part	705015049 or 705015050
Product Line	Select from drop-down
System Code	11
Symptom Comments	Enter Bulletin Number
Defect Comments	Enter Bulletin Number
Remedy Comments	Enter Bulletin Number