



INFINITI

VOLUNTARY RECALL CAMPAIGN

Classification: BT23-005A	Reference: ITB23-016A	Date: June 7, 2023
------------------------------	--------------------------	-----------------------

VOLUNTARY SAFETY RECALL CAMPAIGN 2022-2023 QX60; DRIVER'S SEAT RAIL INSPECTION

This bulletin has been amended. See AMENDMENT HISTORY on the last page.
Please discard previous versions of this bulletin.

CAMPAIGN ID #: PC967, PC981
APPLIED VEHICLES: 2022-2023 QX60 (L51)

**Check Service COMM or Dealer Business Systems (DBS)
National Service History to confirm campaign eligibility.**

INTRODUCTION

Infiniti is conducting this voluntary safety recall campaign on certain specific model year 2022-2023 QX60 vehicles to inspect, and if necessary, replace the Driver's Seat Rail. This service will be performed at no charge to the client for parts or labor.

IDENTIFICATION NUMBER

Infiniti has assigned identification numbers PC967 and PC981 to this campaign. The applicable number must appear on all communication and documentation of any nature dealing with this campaign.

RETAILER RESPONSIBILITY

It is the retailer's responsibility to check Service COMM or Dealer Business Systems (DBS) National Service History for the campaign status on each vehicle falling within the range of this voluntary safety recall which for any reason enters the service department. This includes vehicles purchased from private parties or presented by transient (tourist) clients and vehicles in a retailer's inventory. **Federal law requires that new vehicles in retailer inventory which are the subject of a safety recall must be corrected prior to sale. Failure to do so can result in civil penalties by the National Highway Traffic Safety Administration.** While federal law applies only to new vehicles, Infiniti strongly encourages retailers to correct any used vehicles in their inventory before they are retailed.

Bulletins are intended for use by qualified technicians, not 'do-it-yourselfers'. Qualified technicians are properly trained individuals who have the equipment, tools, safety instruction, and know-how to do a job properly and safely. **NOTE:** If you believe that a described condition may apply to a particular vehicle, DO NOT assume that it does. See your Infiniti retailer to determine if this applies to your vehicle.

SERVICE PROCEDURE

1. Open the driver (LH) front door.



Figure 1

2. Move the driver's seat bottom to the fully UP position (Figure 2).



Figure 2

3. Move the driver's seat bottom to the fully REARWARD position and move the seat back fully FORWARD (Figure 3).



Figure 3

4. Open the driver (LH) rear door.



Figure 4

5. From the second-row seat area, locate the Driver's Seat Slide Finisher Inner (Figure 5).
6. Remove the two (2) Driver's Seat Slide Finisher Inner retaining screws (Figure 6).
HINT: Attached with T-20 screws.

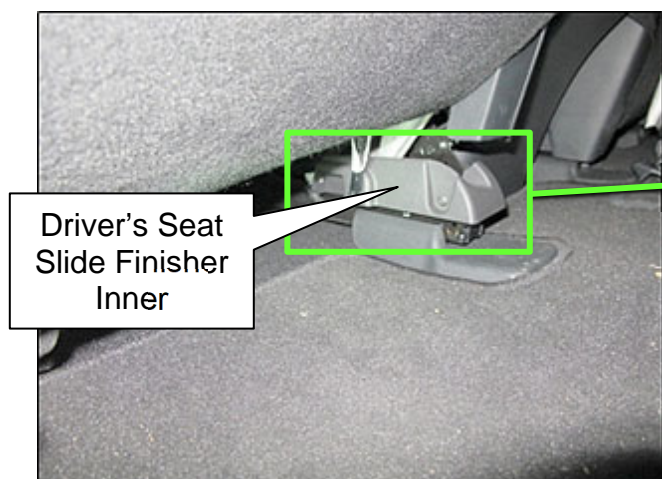

Figure 5

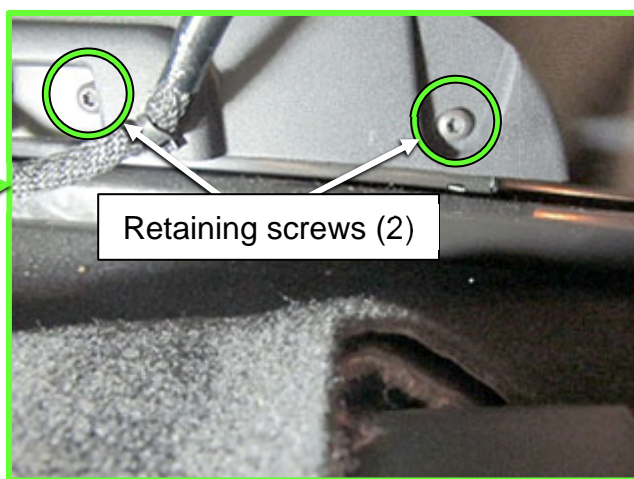

Figure 6

7. Lift up and position the Driver's Seat Slide Finisher Inner out of the way of the Seat Track Inner (Figure 7).

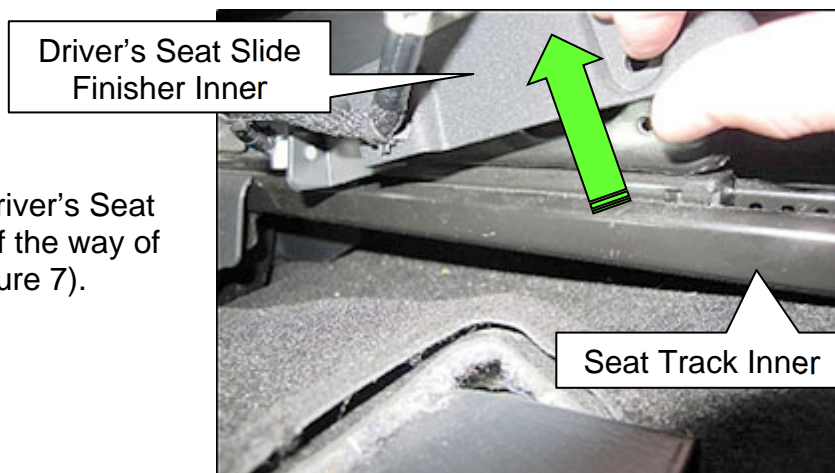

Figure 7

8. Using a 0.55 mm (**0.022 inch**) feeler gauge, attempt to insert the feeler gauge between the Driver's Seat Track Inner and the Seat Slide Inner.
- Verify the 0.55 mm (**0.022 inch**) feeler gauge will not insert at locations A, B or C, between the seat track and seat slide (Figure 10).



Figure 8

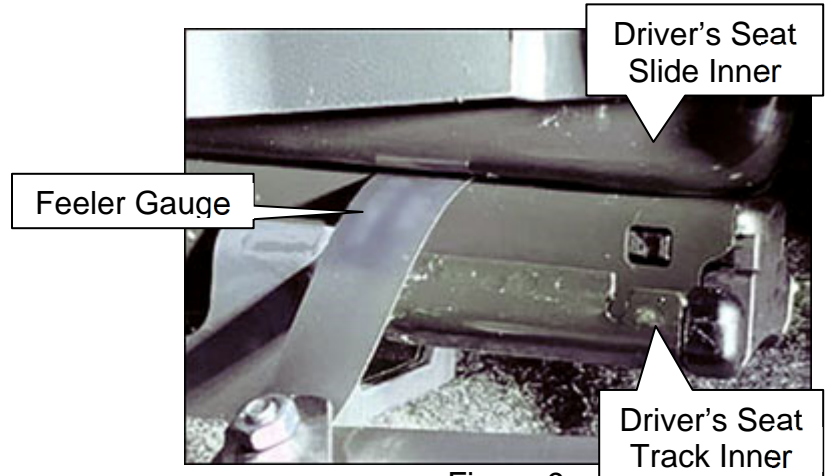

Figure 9

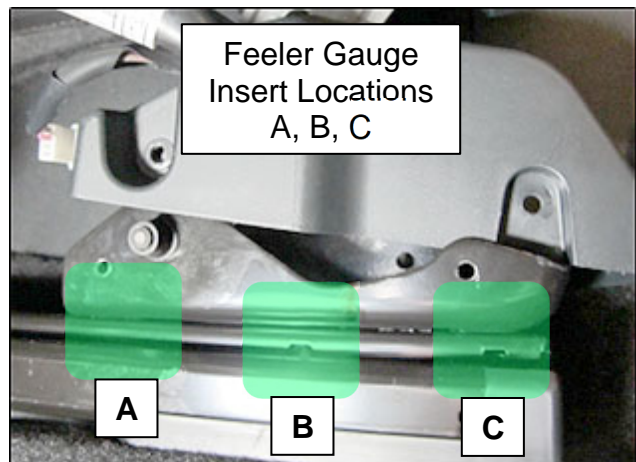

Figure 10

9. Can the 0.55 mm (**0.022 inch**) feeler gauge be inserted between the seat track and the seat slide at A, B or C (any location or multiple locations), where shown in Figure 10?

YES: Proceed to Step 10 on page 5 for WCC support and review of Driver's Seat Cushion Frame Assembly.

NO: No repair is required. Skip to Step 12 on page 6 to reinstall the Driver's Seat Slide Finisher Inner.

10. Take a clear digital picture of the feeler gauge inserted between the seat track and the seat slide, and a clear picture of the VIN on the certification label.
- Reference Figure 8 on page 4 for the angle that the photo should be taken and send a photo to: claims-inspections@nissan-usa.com
 - Include the following information in the title:
 - Campaign ID#
 - Dealer Code
 - VIN
- HINT:** The picture file type needs to be JPEG, PNG, or PDF.
- Contact the Nissan Warranty Call Center (WCC) at 1-800-258-7008, option 7.
 - WCC will need to provide an approval for the Driver's Seat Cushion Frame Assembly.
 - If WCC does NOT approve the replacement of the Driver's Seat Cushion Frame Assembly, skip to step 12 on page 6, to reinstall the Driver's Seat Slide Finisher.
11. Replace the Driver's Seat Cushion Frame Assembly (Figure 11) ONLY if the feeler gauge can be inserted between the seat track and the seat slide at one or more of the locations shown in Figure 10 on page 4.

- Refer to the ESM: **BODY INTERIOR > SEAT > UNIT DISASSEMBLY > FRONT SEAT > SEAT CUSHION > Seat Cushion**

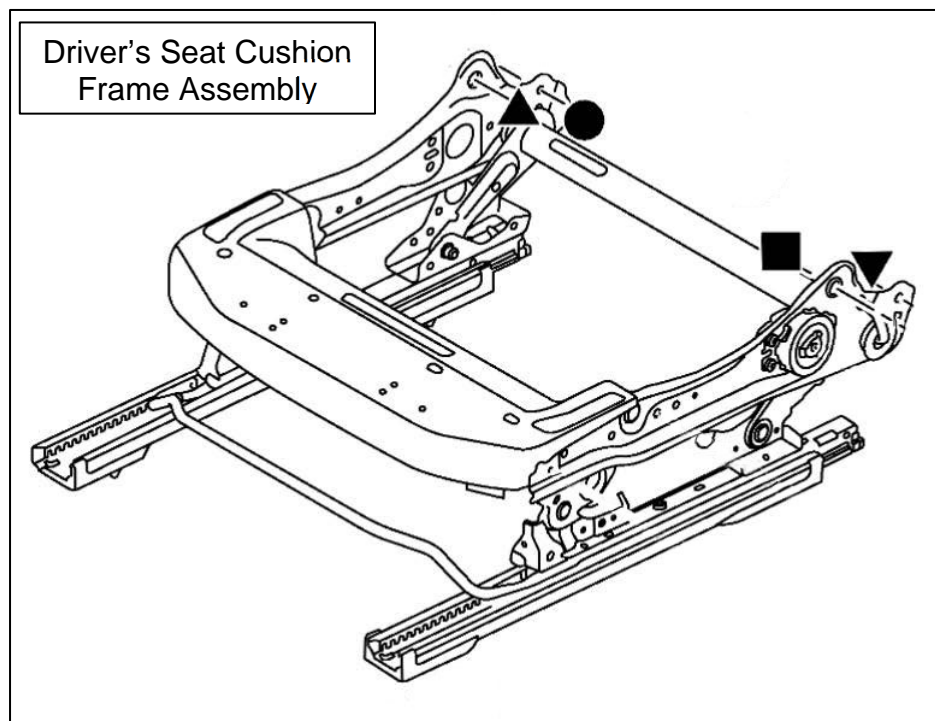

Figure 11

12. Reinstall the Driver's Seat Slide Finisher.
13. Install the two (2) retaining screws.
HINT: Uses T-20 screws.
14. Close the left rear door.
15. Return the driver's seat to its original position.
16. Close the driver's door.

PARTS INFORMATION

DESCRIPTION	PART NUMBER	QUANTITY
FRAME ASSY - CUSHION, FRONT SEAT LH	87351-6TA1A	1

CLAIMS INFORMATION

Submit a "CM" line claim using the following claims coding:

CAMPAIGN ("CM") ID	DESCRIPTION	OP CODE	FRT
PC967	Inspect the Driver's Inner Seat Slide (OK Condition)	PC9670	0.2
	Inspect the Driver's Inner Seat Slide and Replace the Left Front Cushion Frame	PC9671	2.0
PC981	Inspect the Driver's Inner Seat Slide (OK Condition)	PC9810	0.2
	Inspect the Driver's Inner Seat Slide and Replace the Left Front Cushion Frame	PC9811	2.0

AMENDMENT HISTORY

PUBLISHED DATE	REFERENCE	DESCRIPTION
April 13, 2023	ITB23-016	Original bulletin published
June 7, 2023	ITB23-016A	Updated APPLIED VEHICLES, CAMPAIGN ID # , bulletin title and CLAIMS INFORMATION