

## MV204 Egress Upgrade

### MATERIALS:

1 x AR0030053 MV204 Egress Upgrade Kit - RH

### TOOLS:

1 x Prop Bar (Optional, only needed if keeping window in bus)  
1 x 5/32" Hex Wrench  
1 x Flathead Screwdriver  
1 x Blade Scraper  
1 x Wire Cutter Pliers  
1 x #2 Phillips Screwdriver  
1 x Needle Nose Pliers  
1 x #2 Phillips Drill Bit  
1 x Drill Driver  
1 x 760UV Sealant  
1 x Isopropyl Alcohol  
1 x Paper towel or cleaning rag  
1 x 8" Caliper or longer  
1 x Masking Tape Roll  
1 x Clamp  
1 x #30 Drill Bit  
1 x Silicone Lubricant Spray Can  
1 x Tack hammer or Ball Peen Hammer

### PROCEDURE:

Note: It is recommended to remove the mainframe assembly and lay it glass down on a table or bench to allow for easier access to the egress system while performing the upgrade. This is not a necessity but will make removal and installation of the new egress system much more accessible. If the mainframe assembly will be kept in the window, skip steps "Removing the Mainframe Assembly from the Bus" and "Reinstalling the Mainframe Assembly into the Bus". Instead, use the 3' prop bar to hold the mainframe assembly open while performing the upgrade.

#### Removing the Mainframe Assembly from the Bus

1. Pull the emergency release handle located on the jamb of the window and push open the mainframe assembly. See Figure 1.



Figure 1: Egress handle circled in red.

2. Open the mainframe assembly enough to allow access to the hinge retaining screws that are screwed into the female hinge on both sides of the window. These will be visible from the underside of the hinge. See Figures 2a and 2b.



Figure 2a: Mainframe open to expose hinge retention screws.



Figure 2b: Hinge retention screw circled in red.

3. Remove the hinge retaining screws using the 5/32" hex wrench.  
CAUTION: Once the hinge retaining screws have been removed, the male hinge on the mainframe assembly can be disengaged from the female hinge and allow the mainframe to be separated from the subframe if the mainframe assembly is opened a full 90 degrees from the closed position.
4. Remove the mainframe assembly from the subframe by rotating it outward to 90 degrees from resting position and slide it towards the bus body. Be sure to support the mainframe as its weight drops free from the subframe. See Figures 3a and 3b.



Figure 3a: Mainframe open to 90 degrees.

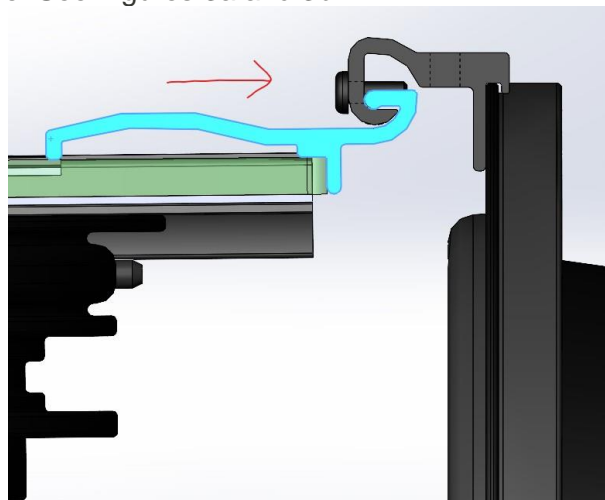

Figure 3b: Slide the mainframe assembly in the direction of the red arrow to separate it from the subframe.

5. Place the mainframe assembly on a clean flat surface with the glass down to allow optimal access to the egress system.  
NOTE: Laying a barrier down, such as cardboard, over the flat surface before placing the mainframe assembly on it can help prevent scratches from getting on the glass.

**Removing the Old Egress System**

- 1. Begin removing the old egress system from the mainframe assembly by using the blade scraper to remove the sealant covering the split pins along the sill of the mainframe. See Figures 4a and 4b.



Figure 4a: Blade scraper removing sealant.



Figure 4b: Sealant removed.

- 2. Use the flathead screwdriver to pry out the locator blocks along the sill of the mainframe. See Figures 5a and 5b.



Figure 5a: Flat head screwdriver wedged in the side of the locator block.



Figure 5b: Locator block pried out of ER track.

3. Once the locator blocks are removed, use the wire cutter pliers to remove the split pins. Grip the side of the split pin that is closest to the glass with the wire cutter pliers. Be sure that the cutting side of the pliers is closest to the glass and contacting the mainframe as shown in Figures 6a and 6b.



Figure 6a: Pliers gripping split pin.

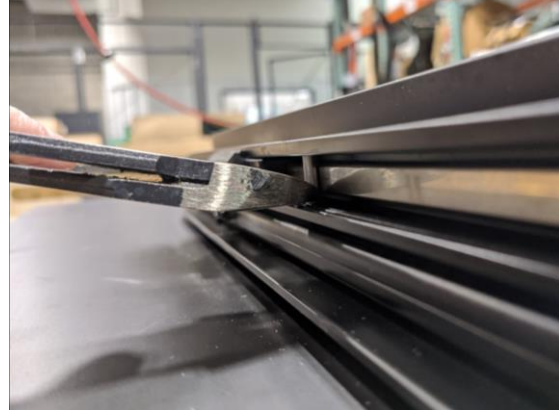

Figure 6b: Bottom of pliers contacting mainframe.

4. Squeeze the pliers tightly and rock the plier handle towards the glass to slide the split pin up a small amount as shown in Figures 7a and 7b.

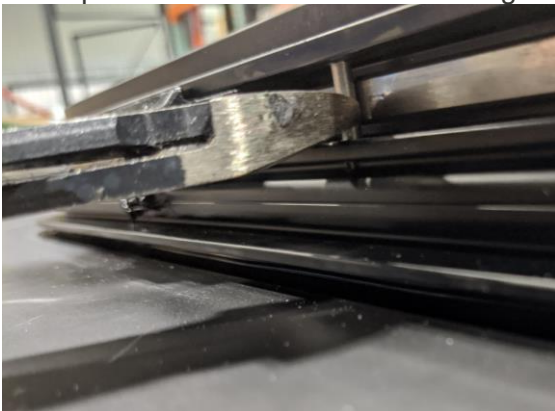

Figure 7a: Pliers rocked, sliding split pin up.

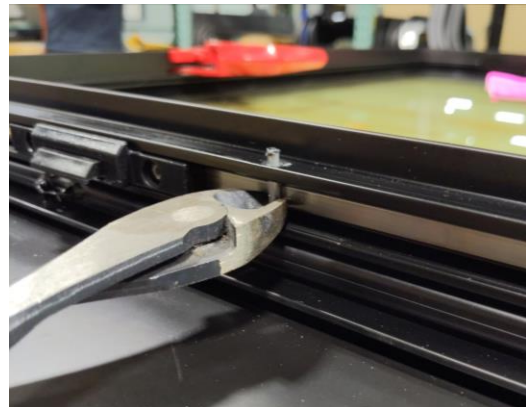

Figure 7b: Split pin slid up.

5. Continue this process of sliding the split pin out until it can be gripped from the interior of the frame. Then reposition the pliers and repeat the same motions until the split pin is removed as shown in Figures 8a and 8b. Do this for all the split pins along the sill of the mainframe.



Figure 8a: Split pin gripped from interior of frame.

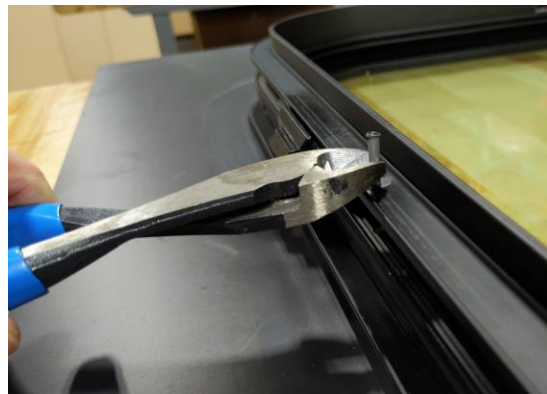

Figure 8b: Split pin slid up.

6. With the split pins removed, the ER bar can be disconnected from the ER handle. Slide the ER bar towards the egress handle a small amount to take pressure off the cable connecting the two together. See Figure 9.



Figure 9: ER bar slid towards ER handle creating slack in ER cable.

7. Use the #2 Phillips screwdriver to remove the screw holding the ER cable to the ER bar. Make sure to keep holding the ER bar after the screw is removed to prevent the ER bar from flinging outwards.
8. With the screw removed, guide the ER bar out of the ER track of the mainframe and set it down as shown in Figure 10.



Figure 10: ER bar removed from ER track.

9. Use the needle nose pliers to assist in removing the ER bar from the ER spring. It may be necessary to bend the hook of the spring outwards slightly to remove the ER bar. See Figures 11a and 11b.



Figure 11a: Hold the ER bar and pull the spring hook with the pliers.



Figure 11b: Pull the hook open with the pliers and slide the ER bar out.

10. Remove the ER handle from the mainframe using the #2 Phillips drill bit and the drill driver to remove the two screws holding it in place. See Figure 12.



Figure 12: Removal of ER handle screws.

11. Once the screws are removed, slide the ER cable through the enlarged section of the slot cutout. See Figure 13.



Figure 13: Use enlarged section of slot cutout to slide cable loops through.

12. Clean out any dirt and grime from the exposed egress track using isopropyl alcohol and either a rag or paper towel. Removal of the old egress system is now complete.

### Drilling Additional Split Pin Holes

1. Add two additional split pin holes to the mainframe to add support to the replacement ER bar. Figure 14 shows the horizontal dimensions that need to be marked on either side of the original split pin holes to drill the additional split pin holes.

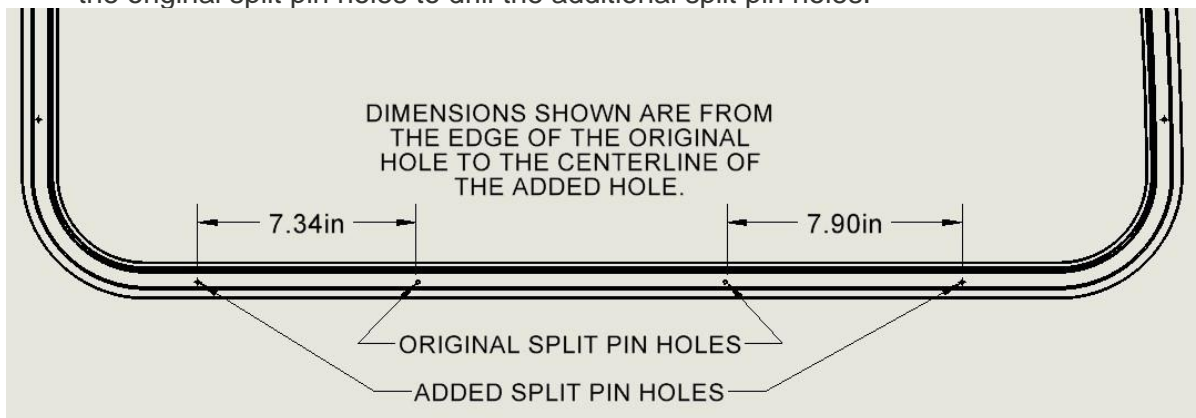

Figure 14: Dimensions for additional split pin holes.

- 2. Use the calipers to mark the horizontal locations for the additional split pin holes. Hook one jaw of the caliper on the edge of the original split pin hole and extend the caliper to the necessary dimension. Use the screw lock on the caliper to prevent the dimension from changing while scoring the new location. See Figures 15a and 15b.



Figure 15a: Jaw hooked on original split pin hole.

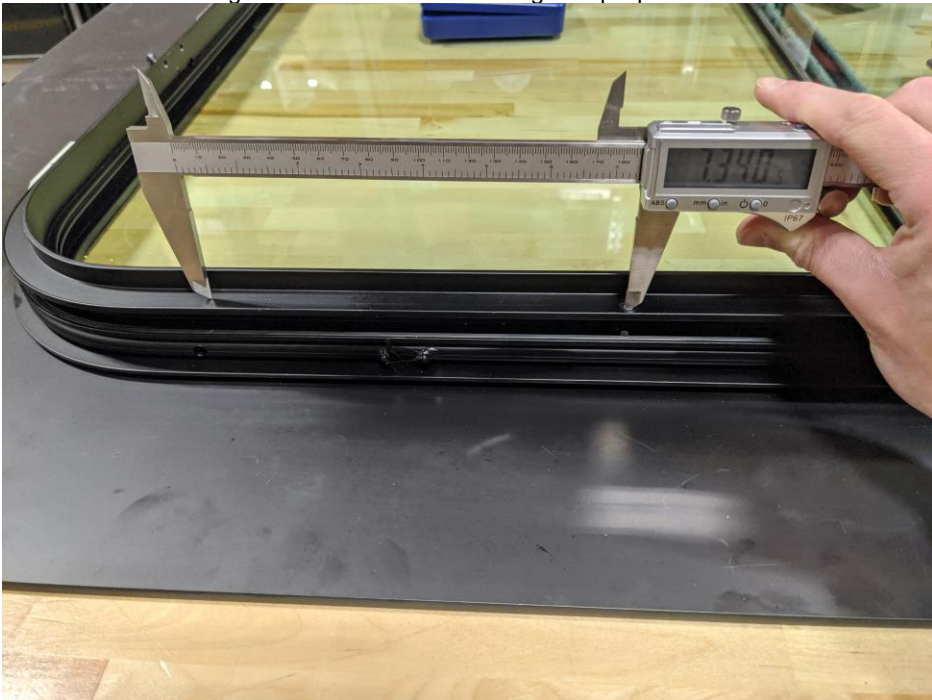

Figure 15b: Caliper extended to dimension for additional split pin.



3. Next, use the other jaw to score a small mark on the mainframe to mark where to align the drill jig for the next step. Repeat this for both sides using each sides respective dimension. See Figures 16a and 16b.

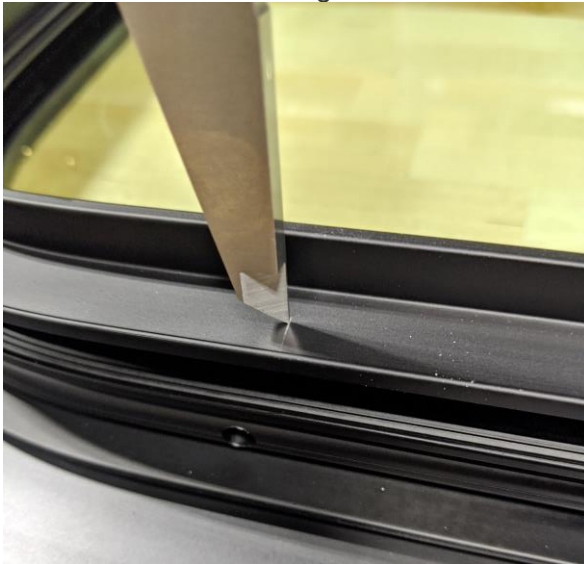

Figure 16a: Jaw used to score frame.



Figure 16b: Scored mark on the frame.

4. Once the locations for the additional split pin holes have been marked, use drill jig AR0030101 to drill the holes in the mainframe. Place the drill jig in the egress track and align it so that the center of the hole is lined up to the mark made in the previous step.
5. Once aligned, use the clamp to clamp the jig in place for drilling. Be sure that the clamp is positioned to apply clamping force to the portion of the jig that rests in the egress track and not to the top portion that extends above the mainframe. If not clamped in this manner, the jig will be tilted, and the hole will be drilled at an angle instead of perpendicular to the mainframe. See Figures 17a and 17b.



Figure 17a: Drill jig clamped correctly.



Figure 17b: Drill jig clamped incorrectly.

6. Apply a piece of masking tape to the #30 drill bit 1.5" from its tip to use as a depth indicator for drilling the additional split pin holes. See Figure 18.



Figure 18: Drill bit taped for depth indication.

7. Use the taped #30 drill bit and the drill driver to drill the hole in the mainframe. Stop when the tape on the drill bit contacts the drill jig. See Figure 19.

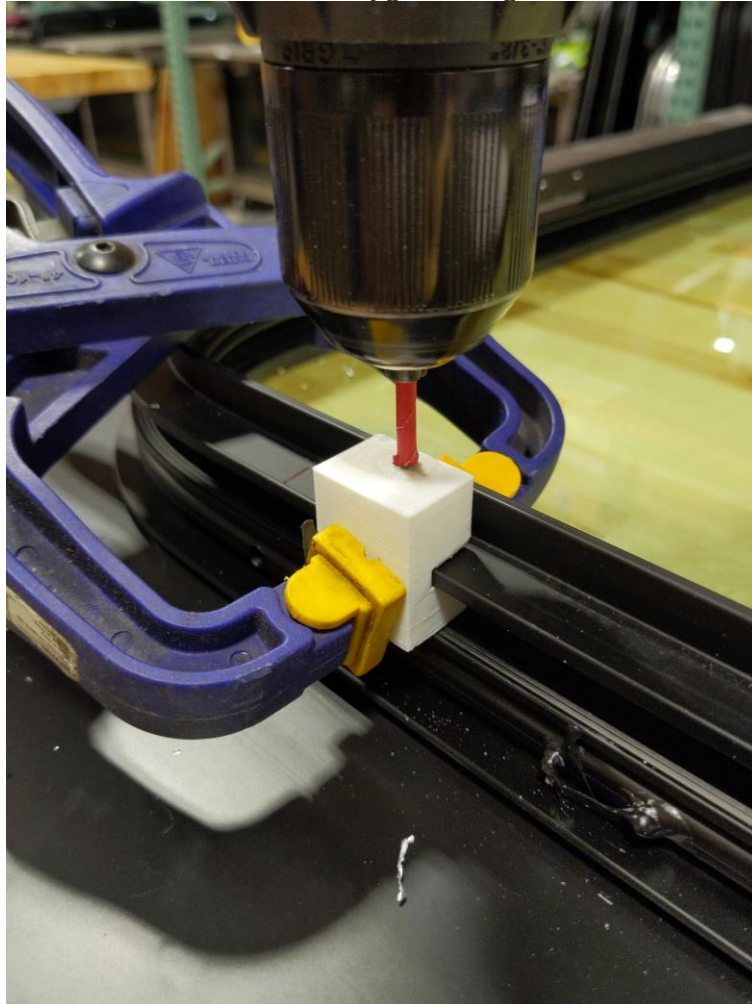

Figure 19: Additional split pin hole drilled to proper depth.

8. Repeat steps 4 through 7 for the second additional split pin hole. Be sure to reference Figure 14 and use the correct dimension for the split pin that is being drilled.
9. Clean out any metal shavings from the frame so that they don't interfere with the operation of the new ER bar assembly. Once both additional holes are drilled and cleaned, the frame is ready for the new egress system to be installed.

### Installing the New Egress System

1. Spray the egress track along the sill of the window with silicone spray for lubrication.
2. Take the new egress handle AR0030047 and install the ER cable through the slot in the mainframe using the enlarged section of the slot to fit the looped ends through. See Figure 20.

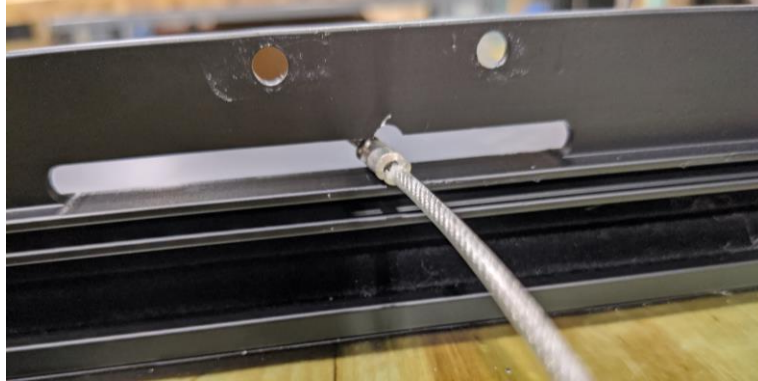

Figure 20: ER cable installed through slot.

3. Apply 760UV sealant to both mounting holes in the ER handle base and then run a bead of sealant between them. See Figure 21.

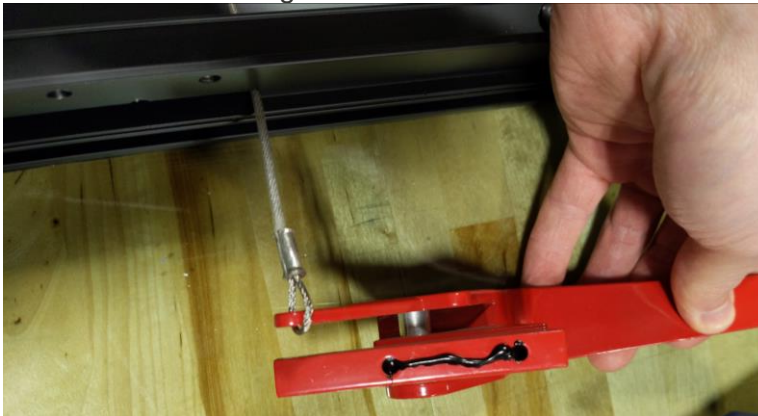

Figure 21: Sealant applied to ER handle base.

4. Secure the ER handle to the mainframe using the drill driver and the #2 Phillips drill bit to install (2) 0001311F screws through the mainframe into the ER handle base. Clean up any squeezed-out sealant as necessary. See Figure 22.

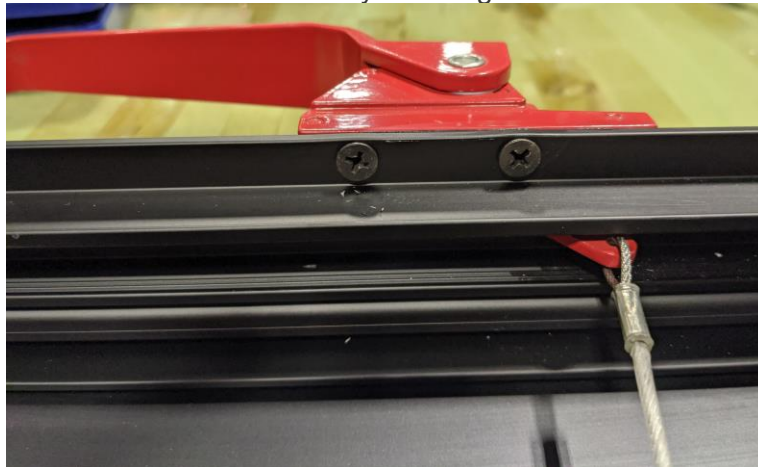

Figure 22: ER handle secured to frame.

5. With the ER handle installed, feed the ER cable down the side of the mainframe and through the locator block and split pin just below the handle. See Figures 23a and 23b.



Figure 23a: Feed ER cable under locator block.



Figure 23b: ER cable fed under locator block.

6. Take the new ER bar assembly AR0030050 and connect the jogged end to the ER return spring. Bend the hook of the ER return spring around the ER bar once installed. See Figures 24a and 24b.



Figure 24a: Install spring hook into jogged end as shown.



Figure 24b: Bend spring hook closed.

7. Place ER bar screw AR0003222 on the tip of the #2 Phillips screwdriver and install the threads through the loop end of the ER cable. Hold the screwdriver, screw, and cable with one hand, using an index finger to keep the screw on the end of the screwdriver as shown in Figure 25.



Figure 25: Screw and ER cable held on screwdriver.

8. With the other hand, place the ER bar assembly into the ER track of the mainframe and slide it towards the ER handle with enough room to install the ER bar screw and hold it in place. See Figure 26.



Figure 26: ER bar held in place with enough room to install ER handle cable.

9. Screw the ER bar screw into the ER bar assembly loose enough that the ER cable can move freely. See Figures 27a and 27b.



Figure 27a: Installation of ER bar screw.



Figure 27b: Screw partially installed with ER cable loose.

10. Release pressure on the ER bar assembly and let the ER return spring pull the slack out of the system. See Figure 28.



Figure 28: ER cable without slack.

11. Fully tighten the ER bar screw.
12. Function test the ER system by pulling the ER handle a few times to ensure the ER bar assembly freely slides forward and returns to its original position.
13. Install 2 of locator block AR0019292 into the ER track along the sill of the window between the ER latches of the ER bar. The locator blocks press into the channel but can be tapped in with a tack or ball peen hammer if necessary. See Figure 29.



Figure 29: Locator blocks between ER latches.

14. Center each block on one of the split pin holes that are between the ER latches. If the ER latch is too close to the split pin hole to allow the locator block to be centered on the split pin hole, position the locator block with an 1/8" gap between it and the ER latch as shown in Figure 30.

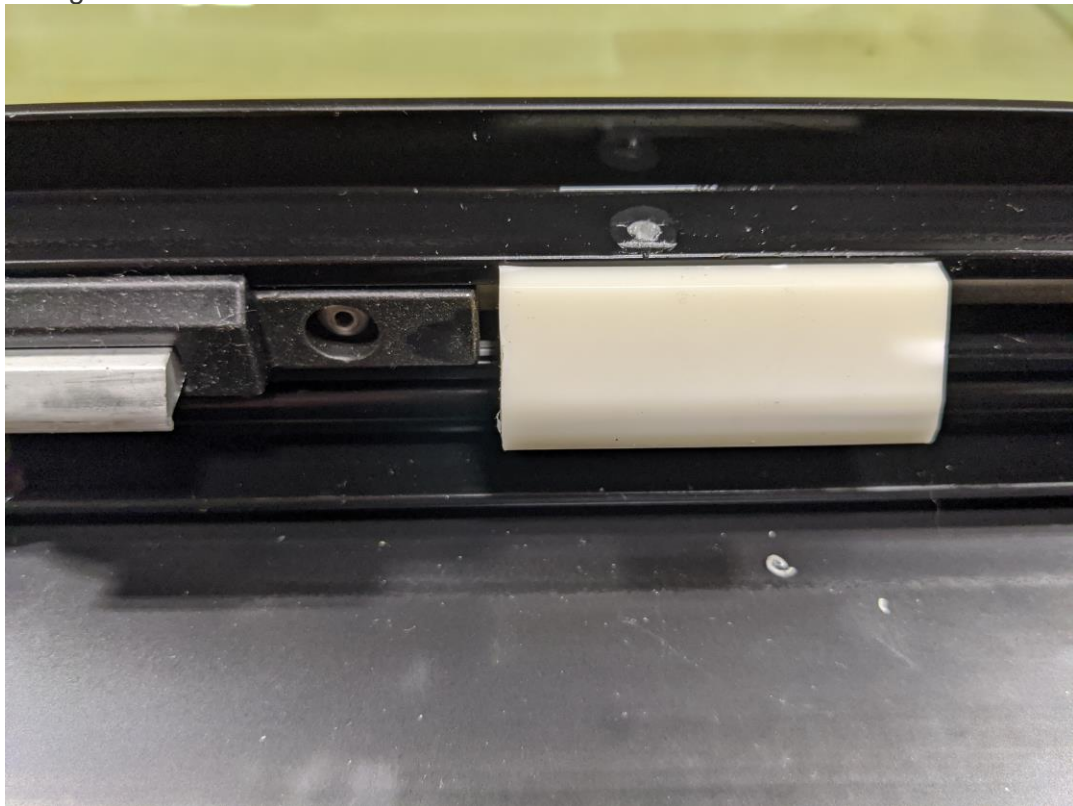

Figure 30: Offset locator block with gap between ER latch and block.

15. Install 1 of locator block AR0020076 into the ER track along the sill of the window between the ER return spring and the ER latch. See Figure 31.



Figure 31: Locator block installed between ER return spring and ER latch.

16. Center the block on the split pin hole that was drilled in this location. If the ER latch is too close to the split pin hole to allow the locator block to be centered on the split pin hole, position the locator block with an 1/8" gap between it and the ER latch as shown in Figure 30 above.
17. With the locator blocks centered on their respective split pin holes, take the #30 drill bit and the drill driver and drill through the locator blocks using the split pin holes as guides. Do not drill the split pin holes in the frame any deeper than they already are, just drill through the locator blocks to allow the split pins to be installed. See Figures 32a and 32b.



Figure 32a: Prior to drilling.

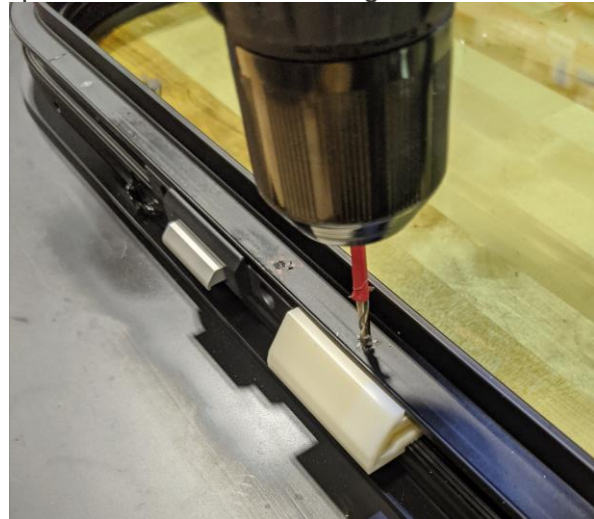

Figure 32b: After drilling.

18. Blow out the plastic shavings once the locator blocks have been drilled out. Actuating the ER handle while blowing the shavings out can help clear all of the shavings out of the system.

19. Install 4 of split pin 0001110F into the split pin holes along the sill of the mainframe. Use the tack hammer or a ball peen hammer to tap them flush with the mainframe. See Figures 33a and 33b.

NOTE: The split pin hole closest to the ER handle does not have a locator block installed centered on it. That split pin hole only gets a split pin installed into it.



Figure 33a: Split pin prior to installation.

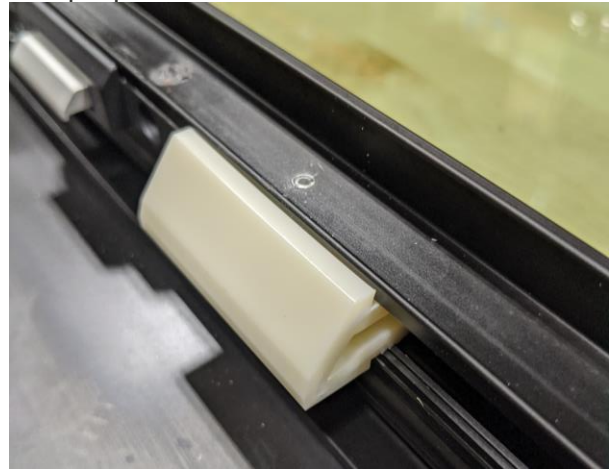

Figure 33b: Split pin installed flush to mainframe.

20. Function test the ER system by pulling the ER handle a few times to ensure the ER bar assembly freely slides forward and returns to its original position. There may be a slight gritty feel as the ER handle passes beyond half of its actuation distance. This is acceptable and will not affect the ability of the egress system to function properly and within acceptable limits.
21. Clean the surface of the split pin and frame with alcohol then cover all the newly installed split pins with 760UV sealant and let sit for 1 hour before reinstalling into the bus. See Figure 34.

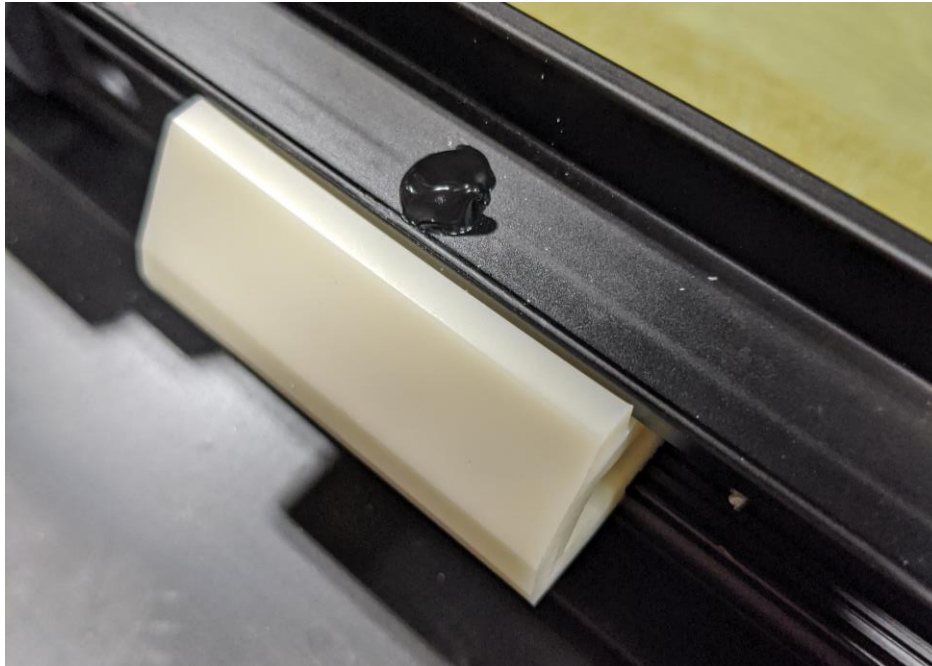

Figure 34: Sealant applied to split pin.



22. Once the 760UV sealant has cured for 1 hour, spray each newly installed locator block with silicone spray for lubrication as shown in Figure 35. The new egress system has now been fully installed and the mainframe assembly is ready to be reinstalled into the bus.



Figure 35: Silicone spray lubricant applied to locator block.

### **Reinstalling the Mainframe Assembly into the Bus**

1. Reinstall the mainframe assembly into the bus by reversing the steps listed in section “Removing the Mainframe Assembly from the Bus” above.
2. Once the mainframe hinge is hooked, and the hinge retention screws have been reinstalled, visually inspect the alignment of the egress latches to the egress strikes to ensure that they are in alignment with each other.
3. Close the mainframe by pushing it open to a 45-degree angle and letting it drop closed on the subframe. If the window does not fully latch, open it to a greater angle and repeat until the mainframe fully latches on the subframe. The mainframe assembly is now reinstalled into the bus.