

TO: Mercedes-Benz Dealer Principals, General Managers, Sales Managers, Service Managers, Parts Managers	FROM: Gregory Gunther, Senior Manager, Vehicle Compliance and Analysis, Engineering Services
RE: <b>Recall Campaign Launch Notification</b> <b>Add Inspection Gauge and Supplemental Booklet for Checking Rear Brake Pads</b> <b>MY19-21 A-Class, CLA, GLA and GLB (177, 118, 247 platform)</b>	DATE: February 16, 2024

**IMPORTANT RECALL CAMPAIGN UPDATE**

Please see the attached documents related to the campaign listed above.

Please note that all customer inquiries should be directed to the Customer Assistance Center at 1-800-FOR-MERCEDES.

Sincerely,

Gregory Gunther

Senior Manager, Vehicle Compliance & Analysis



Recall Campaign Launch Notification			February 16, 2024
Campaign No. :	NHTSA ID	Campaign Desc. :	<b>Add Inspection Gauge and Supplemental Booklet for Checking Rear Brake Pads</b>
2024010010	23V732	23P4296005	
<p>This is to notify you of the <b>Recall Campaign Launch</b> to add a brake inspection gauge and respective owner’s manual information on <b>42,742</b> Model Year (“MY”) 2019-2021 A-Class, CLA, GLA and GLB (177, 118, 247 platform) vehicles. The recall campaign will be visible on the www.NHTSA.gov website and may generate questions from customers. Affected VINs will be flagged in VMI as “OPEN” on <b>February 16, 2024</b>.</p>			
Background			
<b>Issue</b>	Mercedes-Benz AG (“MBAG”), the manufacture of Mercedes-Benz vehicles, has determined that certain MY 2019-2021 A-Class, CLA, GLA and GLB (177, 118, 247 platform) vehicles might not be equipped with the inspection gauge for checking the wear of the rear axle brake pads. Furthermore, the respective information for using this inspection gauge might not be included in the owner’s manual.		
<b>What We’re Doing</b>	MBUSA will conduct a voluntary recall. An authorized Mercedes-Benz dealer will add a brake inspection gauge and the respective owner’s manual information to the affected vehicles, if necessary.		
<b>Parts</b>	<b>The remedy is available and can be performed.</b>		
Vehicles Affected			
<b>Vehicle Model Year(s)</b>	2019-2021		
<b>Vehicle Model</b>	A-Class, CLA, GLA and GLB		
Vehicle Populations			
<b>Total Recall Population</b>	42,742		
<b>Total Vehicles in Dealer Inventory</b>	0		
<p><b>Given this notice, it is a violation of Federal law for a dealer to sell or lease any new vehicles in dealer inventory covered by this notification until the vehicle has been repaired. Once the remedy is available, the vehicles will be flagged as “OPEN” and Work Instructions will be available in NetStar VMI and Xentry Portal. Once the repair is complete, the vehicle may be sold or leased.</b></p> <p><b>Loaner and demonstrator vehicles may continue to be driven, but must not be retailed until repaired. As a matter of normal service process, please check for other repair measures which might be applicable to the vehicle(s).</b></p> <p><b>Additionally, given this notice, it is a violation of Federal Law for car rental companies to rent new vehicles covered by this notification until the vehicle has been repaired.</b></p>			
Next Steps/Notes			
<b>Customer Notification Timeline</b>	Customer letters will be mailed on February 29, 2024.		
<b>AOMS/SOMS</b>	AOMs – This recall may generate questions from your dealers. Please forward this notice to your dealers ASAP.		
<b>Rental Fleet Partners</b>	This recall may affect vehicles in your fleet. Please contact your respective MBUSA fleet representative for further information and next steps. For repairs, please contact your preferred Mercedes-Benz dealer.		
<b>Customer Reimbursement</b>	Customer reimbursement is not being offered for this campaign.		
<p>While we regret any inconvenience this may cause, MBUSA is determined to maintain a high level of vehicle quality and customer satisfaction. Please refer all customer inquiries to the Customer Assistance Center at 1-800-FOR-MERCEDES.</p>			



# Recall Campaign Bulletin



Mercedes-Benz

Campaign No.2024010010, February 2024

TO: ALL MERCEDES-BENZ CENTERS

SUBJECT: **Model A-Class, CLA, GLA, and GLB (177, 118, and 247 platform)  
Model Year 2019-2021**

## **Add Inspection Gauge and Supplemental Booklet for Checking Rear Brake Pads**

Mercedes-Benz AG (“MBAG”), the manufacture of Mercedes-Benz vehicles, has determined that certain MY 2019-2021 A-Class, CLA, GLA and GLB (177, 118, 247 platform) vehicles might not be equipped with the inspection gauge for checking the wear of the rear axle brake pads. Furthermore, the respective information for using this inspection gauge might not be included in the owner’s manual. An authorized Mercedes-Benz dealer will add a brake inspection gauge and the respective owner’s manual information to the affected vehicles, if necessary.

Prior to performing this Campaign:

- VMI must be checked before performing campaigns to verify that the campaign is required on a specific vehicle. Always check for any other open campaigns, and perform accordingly.
- Please review the entire Campaign bulletin and follow the repair procedure exactly as described.

Approximately 42,742 vehicles are affected.

Order No. P-RC-2024010010

# Recall Campaign Bulletin

Recall Campaign Bulletin

Recall Campaign Bulletin

Recall Campaign Bulletin

Recall Campaign Bulletin

## Add Inspection Gauge and Supplemental Booklet for Checking Rear Brake Pads

---

### Work Procedure

1. Open vehicle booklet and check whether gauge (**Figure 1**) is present; enclose if necessary.
2. Check whether supplementary booklet (**Figure 2**) is present; enclose if necessary.

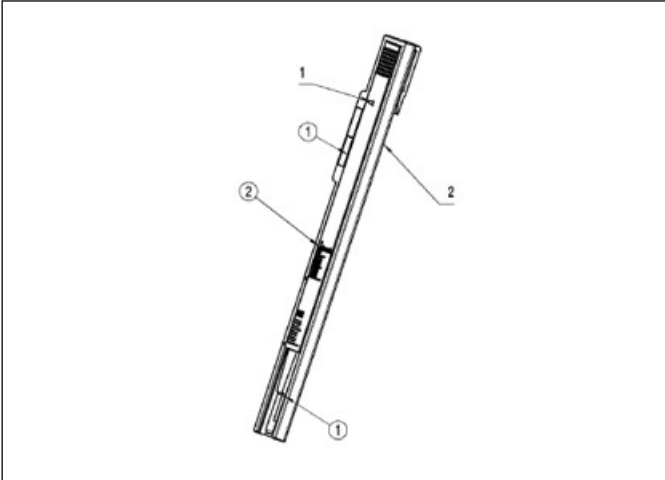

Figure 1 (Gauge A 000 583 06 42)

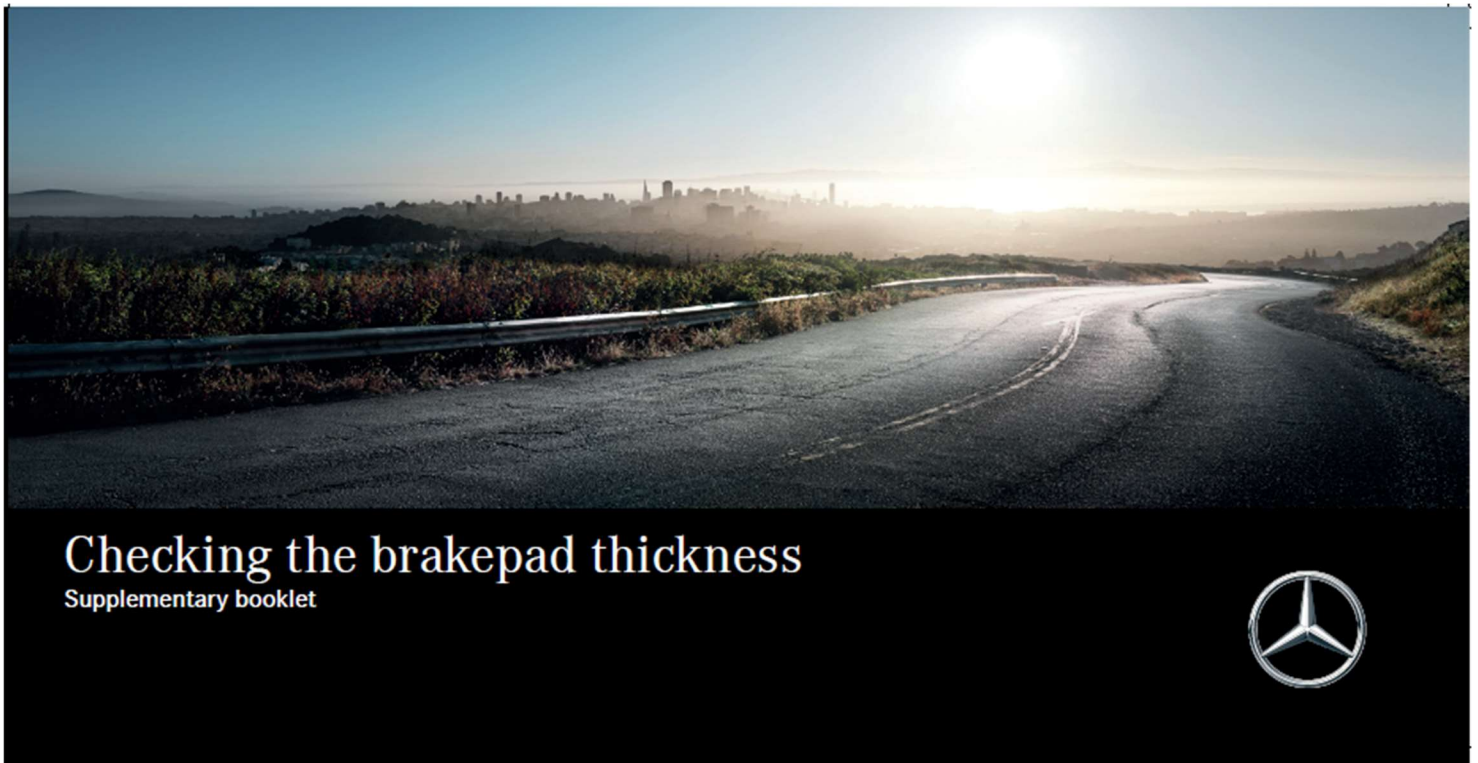

Figure 2 (Supplementary Booklet)

**Primary Parts Information**

Qty.	Part Name	Part Number
As required (1)	Gauge	A 000 583 06 42
As required (1)	Supplementary booklet	A 118 584 63 04

**i** **Note:** *The following allowable labor operation should be used when submitting a warranty claim for this repair:*

**Warranty Information**

Damage Code	Operation Number	Description	Labor Time (hrs.)
42 960 05	02-9471	Check if inspection gauge and supplementary booklet are present, enclose if necessary	0.1

**i** **Note:** *Always check Xentry Operation Time (XOT) for the current OP-Code times. Labor times are subject to change and updates may not be reflected in this document.*