



Stacy L. Balzer
 Director
 Service Engineering Operations
 Ford Customer Service Division

Ford Motor Company
 P. O. Box 1904
 Dearborn, Michigan 48121

June 10, 2024

TO: All U.S. Ford and Lincoln Dealers

SUBJECT: **NEW VEHICLE DEMONSTRATION / DELIVERY HOLD – Safety Recall 23S55 - *Supplement # 3***
 Certain 2020-2022 Model Year Explorer Vehicles
 Rear Axle Bolt Fractures

REF: **NEW VEHICLE DEMONSTRATION / DELIVERY HOLD – Safety Recall 23S55 - Supplement # 2**
 Dated: April 11, 2024

New! REASON FOR THIS SUPPLEMENT

- *Technical Information: Updated Tech Instructions procedures.*
- *Labor Allowances: Labor Operations updated.*

AFFECTED VEHICLES

Vehicle	Model Year	Assembly Plant	Build Dates
Explorer	2020	Chicago	October 22, 2018 through September 27, 2020
	2021	Chicago	June 4, 2020 through November 10, 2021
	2021	Chicago SHO Center	September 14, 2020 through November 6, 2021
	2022	Chicago	June 29, 2021 through July 6, 2022
	2022	Chicago SHO Center	June 25, 2021 through May 20, 2022
Explorer Police	2020	Chicago Assembly / Chicago SHO Center	November 9, 2018 through September 15, 2020
	2021		September 14, 2020 through November 10, 2021
	2022		June 25, 2021 through May 20, 2022

U.S. population of affected vehicles: 238,712. Affected vehicles are identified in OASIS and FSA VIN Lists.

NOTE: This program superseded 22N06. All unrepaired vehicles covered under 22N06 are covered by this program.

REASON FOR THIS SAFETY RECALL

In some of the affected vehicles, the rear axle bolt may fracture. A fractured rear axle bolt will allow the rear axle housing to move out of position, resulting in severe noise and vibration. If the rear axle bolt breaks, the driveshaft or half shafts may become disconnected, resulting in loss of transmission torque to the rear wheels. Transmission torque is necessary to hold the vehicle in park and is also needed for the vehicle to move forward or backward.

SERVICE ACTION

Before demonstrating or delivering any new in-stock vehicles involved in this recall, dealers are to replace the rear differential subframe bushing. This service must be performed on all affected vehicles at no charge to the vehicle owner.

To assist vehicle owners to have this repair completed when parts are available, dealers should:

- Arrange to pick up the owner's vehicle and drive it to the dealership for repairs.
 - Re-deliver the owner's vehicle after repairs have been completed.
- Pick-Up & Delivery should be made available for all customers. Refer to the Rental and Claiming sections for further details.

ESSENTIAL SPECIAL SERVICE TOOLS

If you do not have the special tools needed, please contact 1-800 ROTUNDA and choose option 3 to place an order to purchase.

OWNER NOTIFICATION MAILING SCHEDULE

Parts to repair this condition are currently not available in sufficient quantities to service all of the affected vehicles. Therefore, to ensure an ample supply of parts is available, owners of affected vehicles will be notified in separate mailings. The mailings started the week of January 8, 2024. Dealers should repair any affected vehicles that arrive at their dealerships, whether or not the customer has received a letter.

Parts Available Owner Letters for the incremental population were mailed the week of February 12, 2024. Dealers should repair any affected vehicles that arrive at their dealerships, whether or not the customer has received a letter.

PLEASE NOTE:

Federal law requires dealers to complete this recall service before a new vehicle is delivered to the buyer or lessee. Violation of this requirement by a dealer could result in a civil penalty of up to \$26,315 per vehicle. Correct all vehicles in your new vehicle inventory before delivery.

New! ATTACHMENTS

- Administrative Information
- *Labor Allowances* and Parts Ordering Information
- *Technical Instructions*
- Mobile Service Repair Assessment
- Vehicle Pick-Up & Delivery Record
- Recall Reimbursement plan
- Owner Notification Letters

QUESTIONS & ASSISTANCE

For questions and assistance, contact the Special Service Support Center (SSSC) via the SSSC Web Contact Site. The SSSC Web Contact Site can be accessed through the Professional Technician System (PTS) website using the SSSC link listed at the bottom of the OASIS VIN report screen or listed under the SSSC tab.

Sincerely,

A handwritten signature in black ink that reads "Stacy L. Balzer". The signature is written in a cursive style with a large, looped initial 'S'.

Stacy L. Balzer

Safety Recall 23S55 - *Supplement # 3*

MOBILE SERVICE REPAIR ASSESSMENT LEVEL

- All repairs in this program have the following assessment level.
⊗ - Not a Mobile Service Repair

OASIS ACTIVATION

OASIS was activated on October 9, 2023.

OASIS was activated on January 25, 2024 for the incremental population.

FSA VIN LISTS ACTIVATION

FSA VIN Lists were available through <https://web.fsavinlists.dealerconnection.com> on October 9, 2023. Owner names and addresses were available by January 26, 2024.

FSA VIN Lists for the incremental population was available on January 25, 2024. Owner names and addresses for the incremental population were available by week of February 27, 2024.

NOTE: Your FSA VIN Lists may contain owner names and addresses obtained from motor vehicle registration records. The use of such motor vehicle registration data for any purpose other than in connection with this recall is a violation of law in several states, provinces, and countries. Accordingly, you must limit the use of this listing to the follow-up necessary to complete this recall.

SOLD VEHICLES

- Ford has not issued instructions to stop selling/delivering or driving used vehicles under this safety recall. Owners should contact their dealers for an appointment to have their vehicles remedied as soon as practicable.
- Immediately contact any of your affected customers whose vehicles are not on your VIN list but are identified in OASIS. Give the customer a copy of the Owner Notification Letter (when available) and schedule a service date.
- Correct other affected vehicles identified in OASIS which are brought to your dealership.
- Dealers are to prioritize repairs of customer vehicles over repairs of new and used vehicle inventory.

STOCK VEHICLES

- Correct all affected units in your new vehicle inventory before delivery.
- Use OASIS to identify any affected vehicles in your used vehicle inventory.

DEALER-OPERATED RENTAL VEHICLES

The Fixing America's Surface Transportation (FAST) Act law effective June 2016 prohibits a rental company from selling, renting, or leasing vehicles subject to a safety or compliance recall. Please consult your legal counsel for legal advice.

BRANDED / SALVAGED TITLE VEHICLES

Affected branded / salvaged title vehicles are eligible for this recall.

Safety Recall 23S55 - *Supplement # 3*

OWNER REFUNDS

- **This safety recall must still be performed, even if the owner has paid for a previous repair. Claiming a refund will not close the recall on the vehicle.**
- Ford Motor Company is offering a refund for owner-paid repairs covered by this recall if the repair was performed before the date indicated in the reimbursement plan, which is posted with this bulletin. Owners are directed to seek reimbursement through authorized dealers or, at their option, directly through Ford Motor Company at P.O. Box 6251, Dearborn, MI 48121-6251.
- Dealers are also pre-approved to refund owner-paid emergency repairs that were performed away from an authorized servicing dealer after the end date specified in the reimbursement plan. Non-covered repairs, or those judged by Ford to be excessive, will not be reimbursed.
- Refunds will only be provided for the cost associated with repairs due to a fractured rear differential bolt.

RENTAL VEHICLES

Rental vehicles are not approved for this program.

PICK-UP & DELIVERY- Participating Dealers

Dealers participating in the Remote Experience Program:

- Ford Dealers - Refer to EFC14125, 2024 Remote Experience Program, Pick-Up & Delivery Offset section for additional details.

PICK-UP & DELIVERY- Non-participating Dealers

Ford Dealers not participating in the 2024 Remote Experience Program for Pick-Up & Delivery are authorized to claim unique services for completing this program.

- Dealers are authorized to claim one-half labor hour per repair for vehicle Pick-Up & Delivery services. Refer to Labor Allowances for details.
- Dealers must retain a Vehicle Pick-Up & Delivery Record with the repair order documentation.

ADDITIONAL REPAIR (LABOR TIME AND/OR PARTS)

Additional repairs identified as necessary to complete the FSA should be managed as follows:

- For related damage and access time requirements, refer to the Warranty and Policy Manual / Section 6 – Ford & Lincoln Program Policies / General Information & Special Circumstances for FSAs / Related Damage.
- For vehicles within new vehicle bumper-to-bumper warranty coverage, no SSSC approval is required, although related damage must be on a separate repair line with the “Related Damage” radio button checked.
 - Ford vehicles – 3 years or 36,000 miles
- For vehicles outside new vehicle bumper-to-bumper warranty coverage, submit an Approval Request to the SSSC Web Contact Site before completing the repair.

Safety Recall 23S55 - Supplement # 3**CLAIMS PREPARATION AND SUBMISSION**

- **Claim Entry:** Enter claims using Dealer Management System (DMS) or One Warranty Solution (OWS) online.
 - When entering claims, select claim type 31: Field Service Action. The FSA number 23S55 is the subcode.
 - For additional claims preparation and submission information, refer to the Recall and Customer Satisfaction Program (CSP) Repairs in the OWS User Guide.
- **Related Damage/Additional labor and/or parts:** Must be claimed as Related Damage on a separate repair line from the FSA with the same claim type and subcode as described in Claim Entry above.

IMPORTANT: Click the Related Damage Indicator radio button.
- **Refunds:** Submit refunds on a separate repair line.
 - Program Code: 23S55 - Misc. Expense: ADMIN
 - Misc. Expense: REFUND - Misc. Expense: 0.2 Hrs.
 - Multiple refunds should be submitted on one repair line and the invoice details for each repair should be detailed in the comments section of the claim.
- **Pick-Up & Delivery:**
 - Dealers participating in the Remote Experience Program –
 - Refer to EFC14125, 2024 Remote Experience Program, Pick-Up & Delivery (PDL) Offset section for additional details.
 - Dealers NOT participating in the Remote Experience Program –
 - Dealers may claim one-half labor hour per repair for vehicle Pick-Up & Delivery services.
 - Dealers must retain a Vehicle Pick-Up & Delivery Record with the repair order documentation.
- **Provision for Locally Obtained Supplies:** Includes Loctite® 263 Red High Strength Threadlocker or equivalent. Submit on the same line as the repair.
 - Program Code: 23S55
 - Misc. Expense: OTHER
 - Misc. Expense: Claim up to \$60

Safety Recall 23S55 - *Supplement # 3*

New! NEW LABOR ALLOWANCES

Description	Labor Operation	Labor Time
<i>For vehicle's that contain TWO Axle Cover to Sub-Frame Rear Mounting Bolts. Includes time to raise the vehicle on a Hoist. This completes the Recall.</i>	<i>23S55A</i>	<i>0.3 Hours</i>
Replace the rear subframe bushing, mounting bolt, and ONLY INSPECT the rear differential cover. Includes time to use Mini-Ductor (Or equivalent) to only heat Rear-Differential-Unit (RDU) Front Bushing bolts, drilling the bushing and/or rust/corrosion factor.	23S55D	3.0 Hour(s)
Replace the rear subframe bushing, mounting bolt, INSPECT AND REPLACE rear differential cover. Includes time to use Mini-Ductor (Or equivalent) to only heat Rear-Differential-Unit (RDU) Front Bushing bolts, drilling the bushing and/or rust/corrosion factor.	23S55E	3.6 Hour(s)
Vehicle Pick-Up & Delivery Allowance: This allowance is only for <u>non-eligible</u> 2023 Remote Experience Program Dealers. NOTE: This allowance is for dealer-performed vehicle Pick-Up & Delivery for dealership repairs only. Can only be claimed once, regardless of outstanding FSAs repaired.	23S55PP	0.5 Hours

NOTE: Ensure to claim the correct labor operation for the repair. There are no additional approved labor operations for vehicle inspection(s).

PARTS REQUIREMENTS / ORDERING INFORMATION

- NOTE:** Parts are now available to repair vehicles to support completion on all programs.

Special Program Part Ordering:

To place an order for the Circlips and Updated Bushing, submit a Special Program order in the DOW system. **SSSC contact is not required to order K-Coded parts on this program.** More information can be found in EFC 10642.

Part Number	Description	Order Quantity	Claim Quantity
L1MZ-4B425-D	Revised Rear Subframe Bushing	1	1
-3B498-	Rear Axle Pinion Circlip (All Applications) (Vehicle specific part number – Refer to parts catalog)	1	1
L1MZ-3B498-*	Rear - Inner Halfshaft Circlip (All Applications) (Vehicle specific part number – Refer to parts catalog)	2	2

Dealers will be notified via a DOES II communication if circumstances warrant a change in part supply strategy and when open ordering resumes.

Safety Recall 23S55 - Supplement # 3

PARTS REQUIREMENTS / ORDERING INFORMATION (Continued)

Order the parts below through normal order processing channels:

Parts Required for Subframe Bushing Replacement		Order Quantity	Claim Quantity
L1MZ-4033-C	Differential Axle Cover Housing (ONLY if differential cover requires replacement)	If Needed	
W719362-S439	Toe Link to Knuckle Bolt (1 required – 4 in a pack)	1	1
W520516-S441	Toe Link to Knuckle Nut	1	1
W714297-S440	Lower Arm to Knuckle Nut (1 required – 2 in a pack)	1	1
W720988-S439	Differential Axle Rear Cover Housing Bolt to Rear Subframe (M14X118MM) (1 required – 4 in a pack)	1	1
W717867-S900	Differential Axle Front Bushing Housing Support Bolts to Subframe (M14X132MM) (2 required – 4 in a pack)	1	2
W719459-S439	Upper Arm to Knuckle Bolt (1 required – 4 in a pack)	1	1
W520214-S440	Upper Arm to Knuckle Nut (1 required – 2 in a pack)	1	1
W720034-S440	Shock Absorber Lower Nut (1 required – 4 in a pack)	1	1
LB5Z-3B477-A	Wheel Hub Nut	1	1
W717822-S439	Driveshaft Center Bearing Bolts (2 required – 4 in a pack)	1	2
W719511-S439	Flexplate Coupling to Transmission Bolts (3 required – 4 in a pack)	1	3
XG-1-E1	Grease	As Required	
L1MZ-3C084-A	Halfshaft Seal	2	2
W719430-S439	Brake Caliper Bolts (2 required – 4 in a pack)	1	2
VC-13-G	Motorcraft® Yellow Concentrated Antifreeze/Coolant (3.3 Hybrid ONLY)	As Required	
XY-75W85-QL	Differential Oil	2	2
Obtain Locally	Loctite® 263 Red High Strength Threadlocker or equivalent. NOTE: If Threadlocker availability is not available in your Market, replace the required fasteners per Workshop Manual specifications.	1 tube will service many vehicles	
TA-26	Motorcraft® Red High Strength Threadlocker or equivalent – Specification WSK-M2G351-A6. NOTE: Check original fastener Threadlock color when removing, cleaning and re-using the fasteners. NOTE: If Threadlocker availability is not available in your Market, replace the required fasteners per Workshop Manual specifications.	1 tube will service many vehicles	

Safety Recall 23S55 - *Supplement # 3*

PARTS REQUIREMENTS / ORDERING INFORMATION (Continued)

Parts Required for Rear Differential Cover Replacement		Order Quantity	Claim Quantity
TA-29	Silicone Sealant	As Required	

NOTE: Part numbers may change or supersede to a new service level service part number during the duration of this recall. For the latest and greatest part number, you may also refer to the parts catalog, enter vehicle specific VIN number and order the correct specific parts during the repair.

DEALER PRICE

For the latest prices, refer to DOES II.

PARTS RETENTION, RETURN, & SCRAPPING

Follow the provisions of the Warranty and Policy Manual, Section 1 - WARRANTY PARTS RETENTION AND RETURN POLICIES. If a replaced part receives a scrap disposition, the part must be scrapped by all applicable local, state, and federal environmental protection and hazardous material regulations. Federal law prohibits selling motor vehicle parts or components that are under safety, compliance, or emissions recall.

EXCESS STOCK RETURN

The excess stock returned for credit must have been purchased from Ford Customer Service Division by Policy Procedure Bulletin 4000.

REPLACED FSA PARTS INSPECTION AND SIGN OFF

Effective March 1st, 2021, all parts replaced as part of an FSA repair with a repair order open date of March 1st, 2021, or later must be inspected and signed off on the repair order by a member of your dealer fixed operations management team or an employee of the task has been delegated to. If the task is to be delegated to a non-management employee, the employee needs to be someone other than the technician who completed the repair and needs to understand the importance of completing this task consistently and accurately.

- All parts replaced as part of an FSA repair should be returned to the parts department following the Warranty Parts Retention and Return Policies.
- Inspect the replaced parts to verify the FSA repair was completed.
- If the FSA repair is found to be complete, the designated employee signs the repair order line or parts return stamp area (electronic or hand signed) for the FSA repair indicating the parts were inspected and validated to have been replaced.
- After the parts have been inspected, they should be handled based on the guidance in the parts status report in the Online Warranty System (Hold, Return, CORE, Scrap, etc.). Please visit FMCDEALER > PARTS & SERVICE > WARRANTY ADMINISTRATION & WARRANTY PARTS RETURN for the latest [Immediate Scrap List](#) information.
- This process is subject to review during warranty audits for FSA repairs with a repair order open date of March 1st, 2021, or later. Any eligible FSA claims requiring parts replacement found not to have been inspected and signed off during a warranty audit will be subject to chargeback and consideration for enrollment into the Dealer Incomplete Recall Repair Process.

Safety Recall 23S55 - *Supplement # 3*

REPLACED FSA PARTS INSPECTION AND SIGN OFF (Continued)

Note: Other approvals (electronic or handwritten) for add-on repair lines, dealer-owned vehicle repairs, and repeat repairs do not qualify as FSA parts inspection approvals. The post-repair FSA parts inspection process (electronic or handwritten) is independent of other warranty approval requirements. The approval by the designated employee implies that the FSA parts were found to be replaced and must be able to be identified on the Repair Order. If multiple FSAs require approval on a single Repair Order, each applicable occurrence will require individual post-repair approval by the designated employee.

CERTAIN 2020-2022 MODEL YEAR EXPLORER VEHICLES — REAR AXLE BOLT FRACTURES

NEW! SERVICE PROCEDURE

IMPORTANT! The Service Technician Specialty Training (STST) Competency 10 certification requirement, for U.S. market only, will be enforced starting with repair orders opened on or after April 1, 2024. Field Service Action (FSA) repairs will reject if the repairing technician is not certified in STST Competency 10 FSA. See Electronic Field Communication (EFC) 14251 for more details.

IMPORTANT! This procedure was modified from the original Workshop Manual (WSM) procedures. For this Field Service Action (FSA), multiple bolts and nuts will be cleaned and inspected for re-use. In addition, the Left Hand (LH) rear knuckle will not be fully disassembled when removing the LH rear halfshaft. Follow these technical instructions carefully.

NOTE: If you do not have the special tools referenced in the Workshop Manual (WSM) to perform the FSA repair, please contact 1-800 ROTUNDA and choose option 3 to place an order.

1. With the vehicle in *NEUTRAL*, position it on a hoist. Follow the WSM procedures in Section 100-02.
2. Does the Rear Differential Unit (RDU) contains One or Two RDU axle cover to subframe mounting bolts? See Figures 1 and 2.
 - A. The RDU only contains ONE (1) axle cover to subframe mounting bolt. Proceed to Step 3.
 - B. The RDU contains TWO (2) axle cover to subframe mounting bolts. This Recall is complete and no further repairs are required. Refer to the Dealer Bulletin for RDU claiming instructions.



FIGURE 1





FIGURE 2

3. Measure the distance from the center of the rear hub to the lip of the rear quarter panel with the vehicle in a level, static ground position (curb height).

4. Drain the rear differential fluid. Follow the Workshop Manual (WSM) procedures in Section 205-02.

NOTE: For this procedure it is not necessary to remove the wheel bearing, wheel hub, brake disc shield or lower arm vertical link.

NOTICE: Never pick up or hold the halfshaft by only the inner or outer CV joint. Damage to the CV joint will occur.

NOTICE: Never use a hammer to remove or install the halfshafts. Damage to the CV joint may occur.

NOTICE: Never use the halfshaft assembly as a lever to position other components. Damage to the halfshaft or CV joint may occur.

NOTICE: Do not allow the boots to contact sharp edges or hot exhaust components. Damage to the halfshaft boots will occur.

NOTICE: Do not drop assembled halfshafts. The impact may cut the boots from the inside without evidence of external damage.

NOTICE: Suspension fasteners are critical parts that affect the performance of vital components and systems. Failure of these fasteners may result in major service expense. Use the same or equivalent parts if replacement is necessary. Do not use a replacement part of lesser quality or substitute design. Tighten fasteners as specified.

NOTE: This procedure is only for the Left Hand (LH) side. Right Hand (RH) side shown, LH side similar.

5. Remove the LH rear wheel and tire. Follow the WSM procedures in Section 204-04A.



NOTICE: Do not attempt to jacking on the front control arm or rear control arm on any vehicle.
Damage to control arms may occur.

NOTICE: Make sure that the insulator pads are correctly positioned to prevent direct contact with other components.

NOTE: The below procedures are only for the rear LH side of the vehicle.

6. On the rear LH side of the vehicle, use a suitable jack to raise the suspension until the distance between the center of the hub and the lip of the fender is equal to the measurement taken in Step 3, (curb height). See Figure 3.

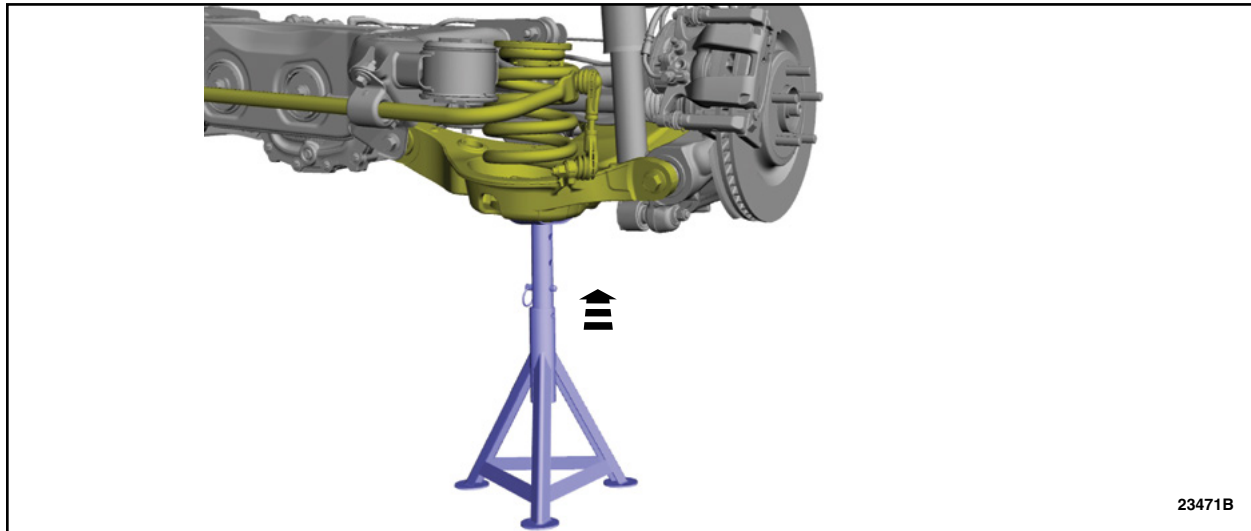

FIGURE 3

7. Remove and discard the LH rear wheel hub nut. See Figure 4.

• Torque: 221 lb.ft (300 Nm).

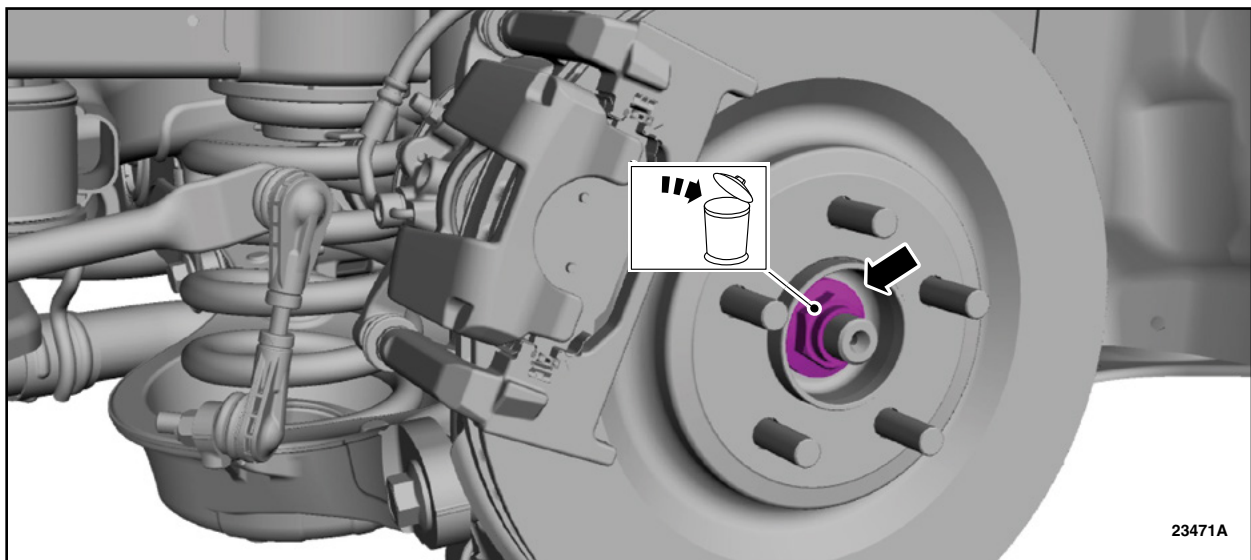

FIGURE 4



8. Remove the LH rear brake disc. Follow the WSM procedures in Section 206-04.

- Caliper anchor plate bolts Torque to: 122 lb.ft (165 Nm).

9. Remove and discard the LH rear shock absorber lower nut. See Figure 5.

- Torque: 59 lb.ft (80 Nm).

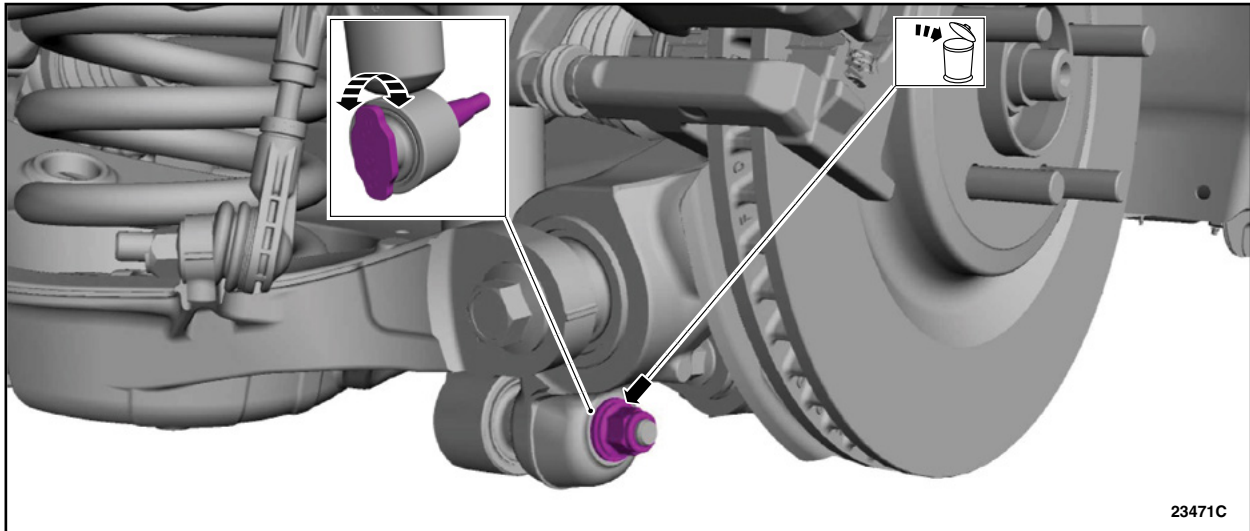

FIGURE 5

10. Remove the LH rear wheel speed sensor bolt and position the wheel speed sensor aside. Then, remove the brake hose bracket bolt and position the brake hose bracket aside. See Figure 6.

- Brake hose bracket bolt torque: 133 lb.in (15 Nm).
- Wheel speed sensor bolt torque: 133 lb.in (15 Nm).

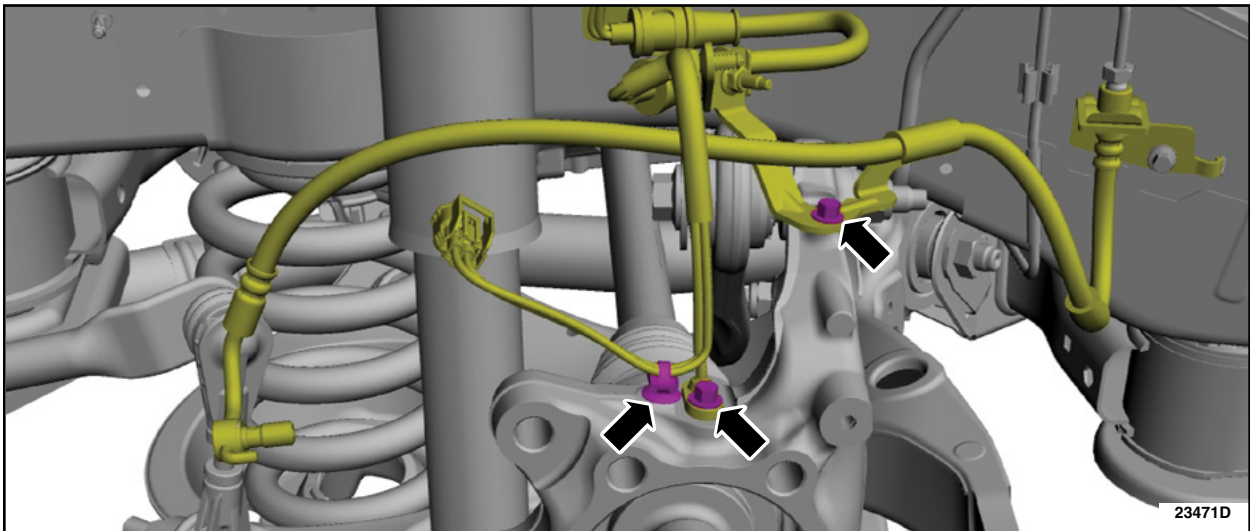

FIGURE 6



11. Remove and discard the LH rear lower arm vertical link lower nut. Then, remove, clean and inspect the LH rear lower arm vertical link lower bolt threads. If the threads are not damaged, apply LOCTITE® 263™, or equivalent (Obtain locally), and reuse the bolt and order a *new* nut. If the threads are damaged order a *new* nut and bolt. See Figure 7.

• Torque: 258 lb.ft (350 Nm).

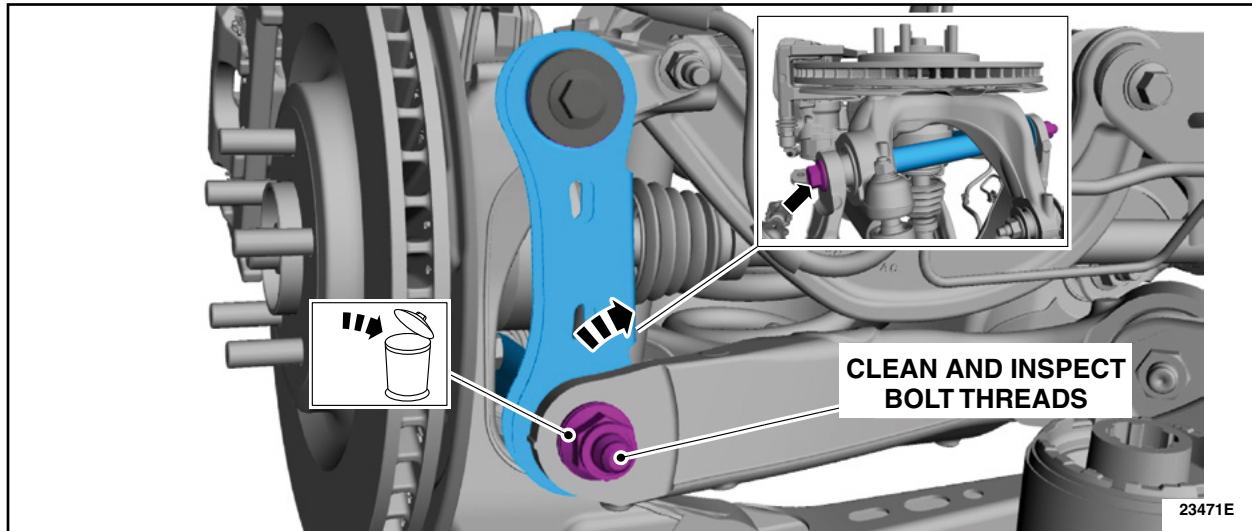

FIGURE 7

12. Remove and discard the LH rear toe link-to-wheel knuckle bolt and nut. See Figure 8.

• Torque: 129 lb.ft (175 Nm).

NOTE: The wheel bearing and dust shield are removed for clarity.

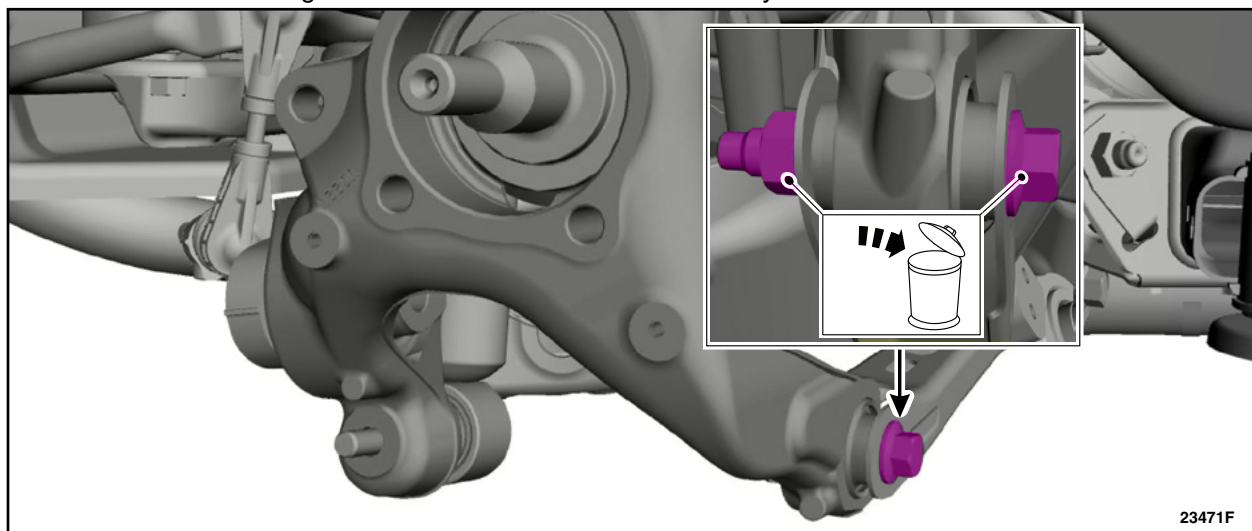

FIGURE 8

13. Position the LH rear knuckle up to remove halfshaft from the rear wheel knuckle.

14. Using a pry bar, remove the LH rear halfshaft from the rear axle assembly.



15. Using a pry bar, disengage the RH rear halfshaft inner cir-clip from the rear axle assembly.
See Figure 9.

NOTE: It is not necessary to remove the RH rear halfshaft from the vehicle.

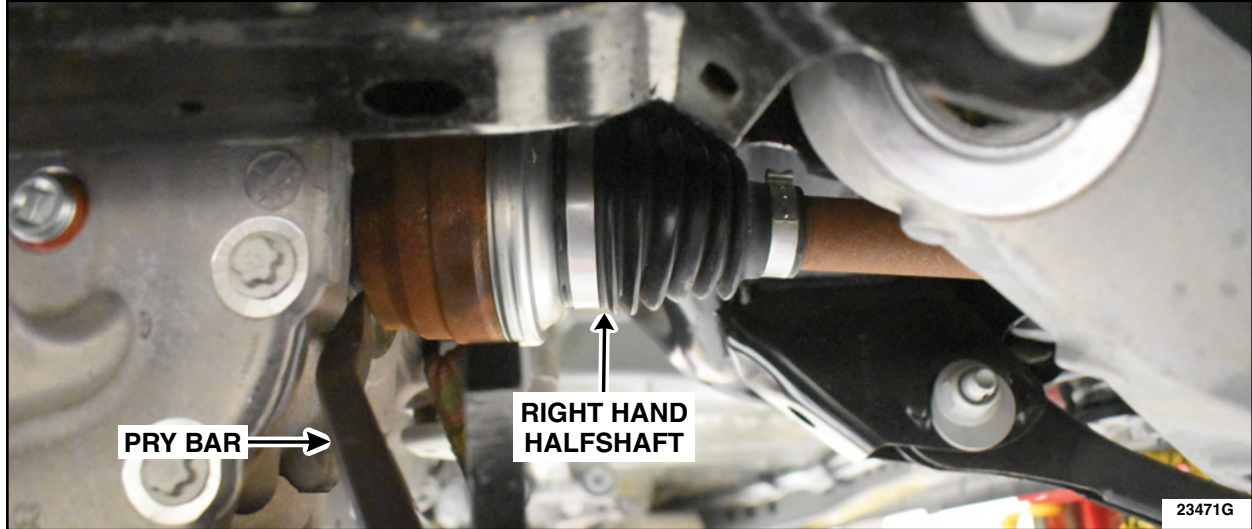

FIGURE 9

16. Secure the rear axle assembly to the transmission jack using a ratchet strap. See Figure 10.

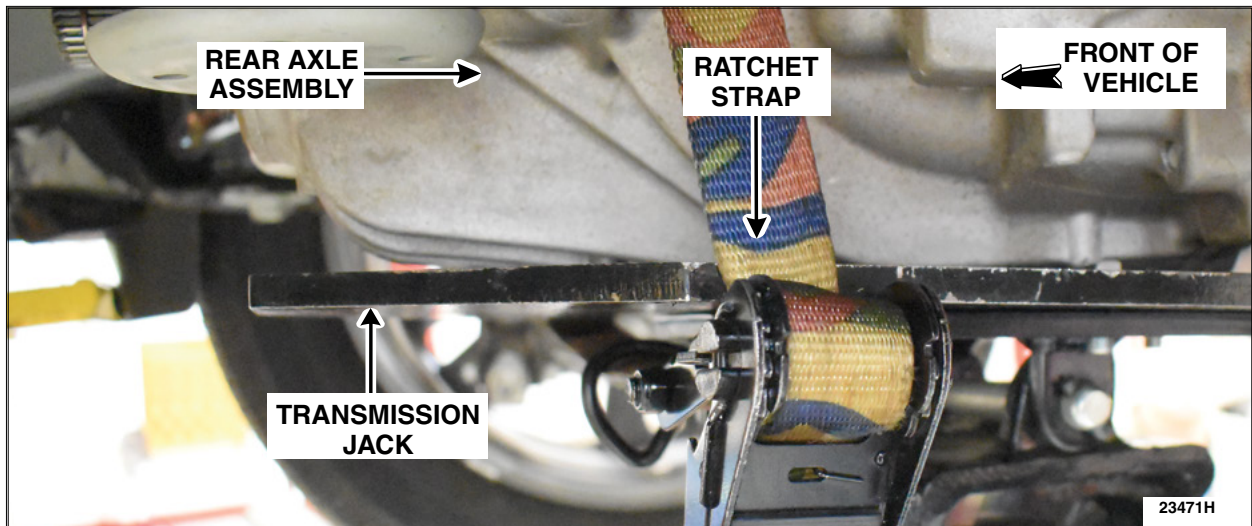

FIGURE 10



NOTE: In the next Step, the muffler, tailpipe, and underbody shields must be removed before removing the rear driveshaft. In addition, it is not necessary to remove the exhaust flexible pipe.

17. Remove the rear driveshaft. Follow the WSM procedures in Section 205-01.

- 100-001 (T50T-100-A) - Slide Hammer
- 205-832 - Remover, Halfshaft

18. Disconnect and position the axle assembly vent hose aside. See Figure 11.

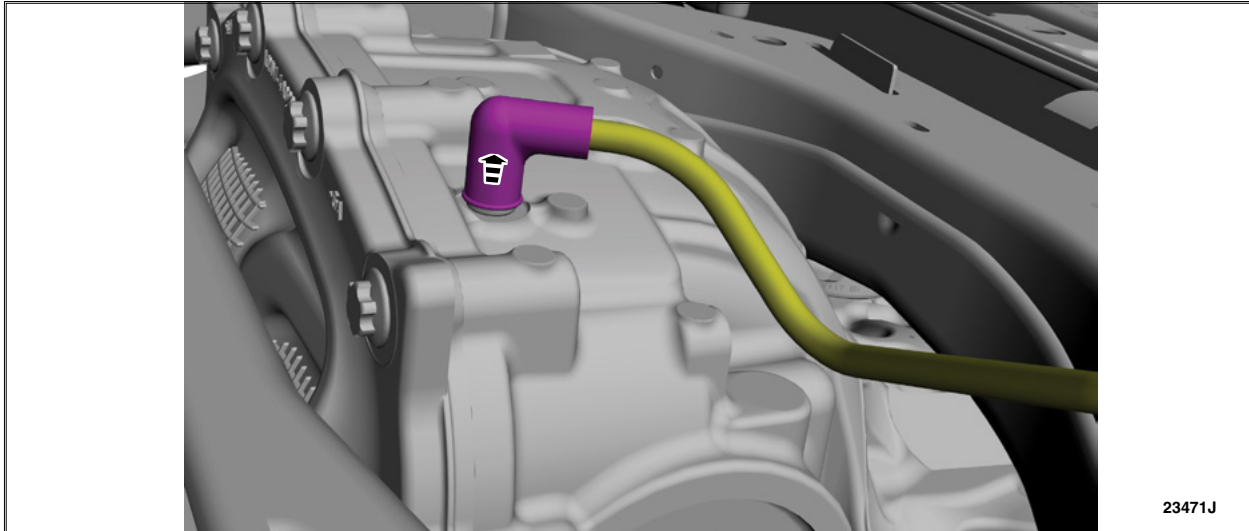

FIGURE 11



19. Using a flameless heat tool, such as the Rotunda Mini-Ductor II (part number IDIMD-700) or equivalent, heat up both front rear axle housing support bolts, as shown in Figure 12. Using a breaker bar, loosen both bolts. Then remove and discard both rear axle housing support bolts. See Figure 13.

• Torque: 129 lb.ft (175 Nm).

NOTE: The use of this tool is only to be used on the front RDU axle bolts.

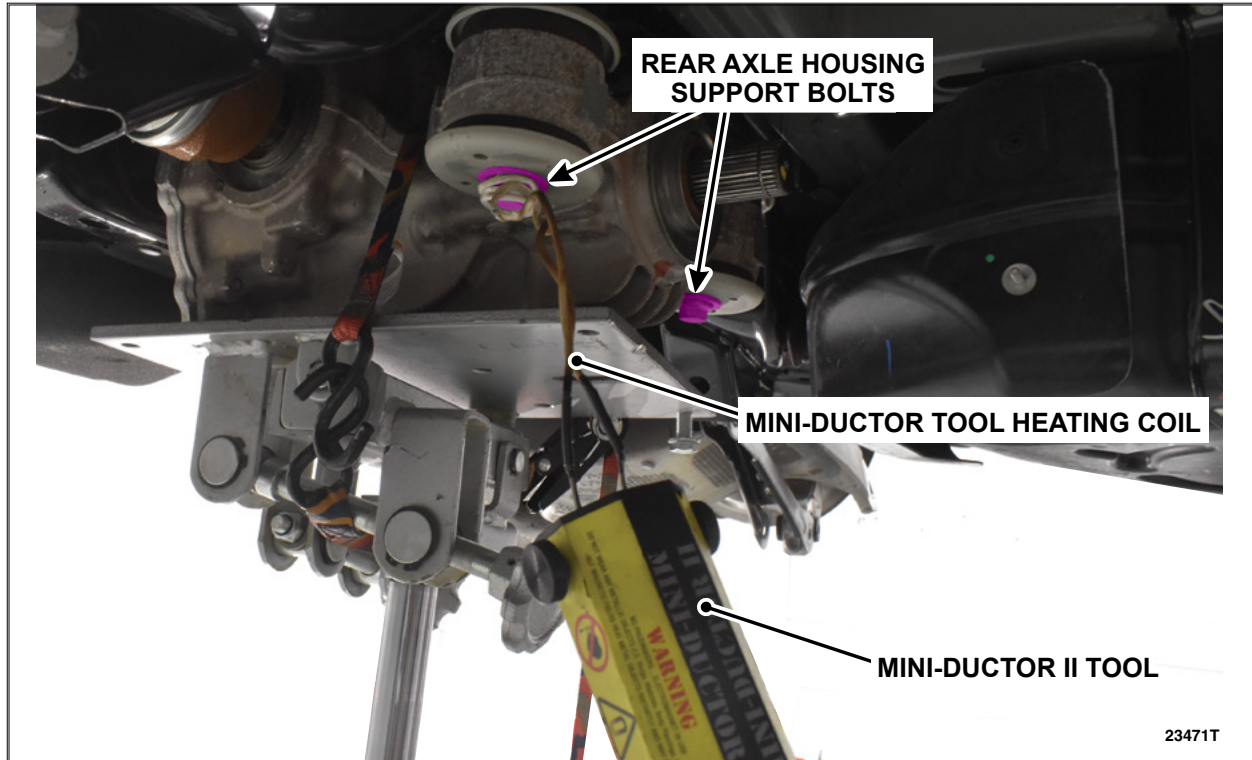

FIGURE 12

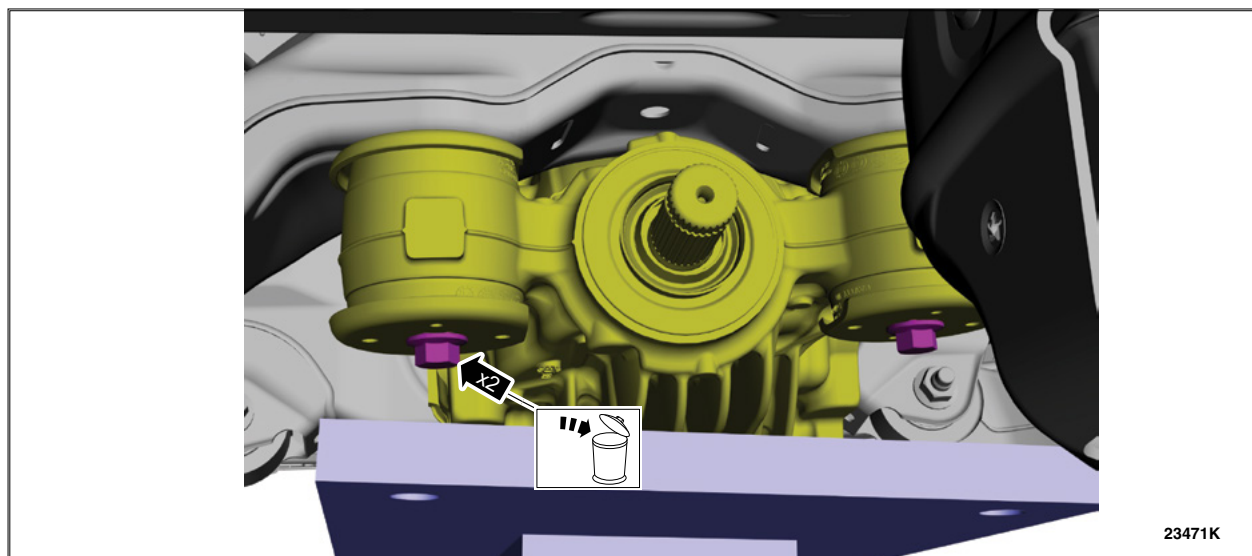

FIGURE 13



20. Remove and discard the rear axle housing support rear bolt. See Figure 14.

- Follow the Torque sequence below:

Stage 1: Torque to: 74 lb.ft (100 Nm).

Stage 2: Tighten an additional: 100°.

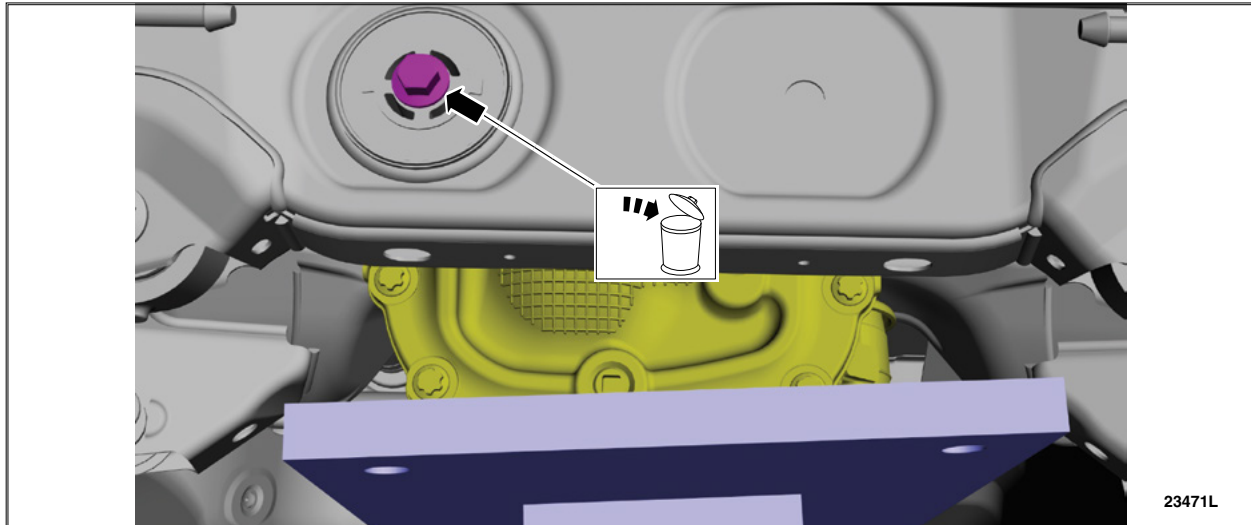

FIGURE 14

21. Gently lower down the transmission jack and remove the rear axle assembly. See Figure 15.
Use the General Equipment: Transmission Jack.

NOTE: Slowly lower the rear axle assembly while positioning it as you are removing the RH halfshaft from the rear axle assembly.

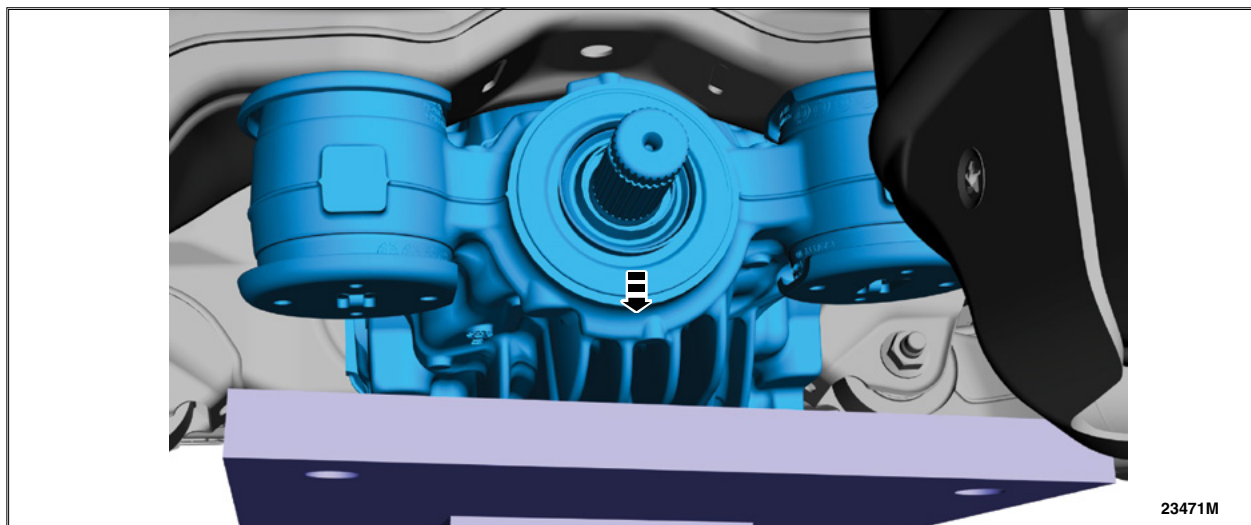

FIGURE 15



22. Visually inspect the rear differential cover bushing boss for damage (broken fastener, scoring, cracks and/or deformation and damaged threads). Is the rear differential cover bushing boss damaged?
See Figures 16 and 17.

YES - Does Not Pass inspection. Install only a *new* differential housing cover (Do Not install the rear axle assembly at this time). Follow the WSM procedures in Section 205-02. Proceed to Step 25.

NO - Passes inspection. Proceed to Step 23.

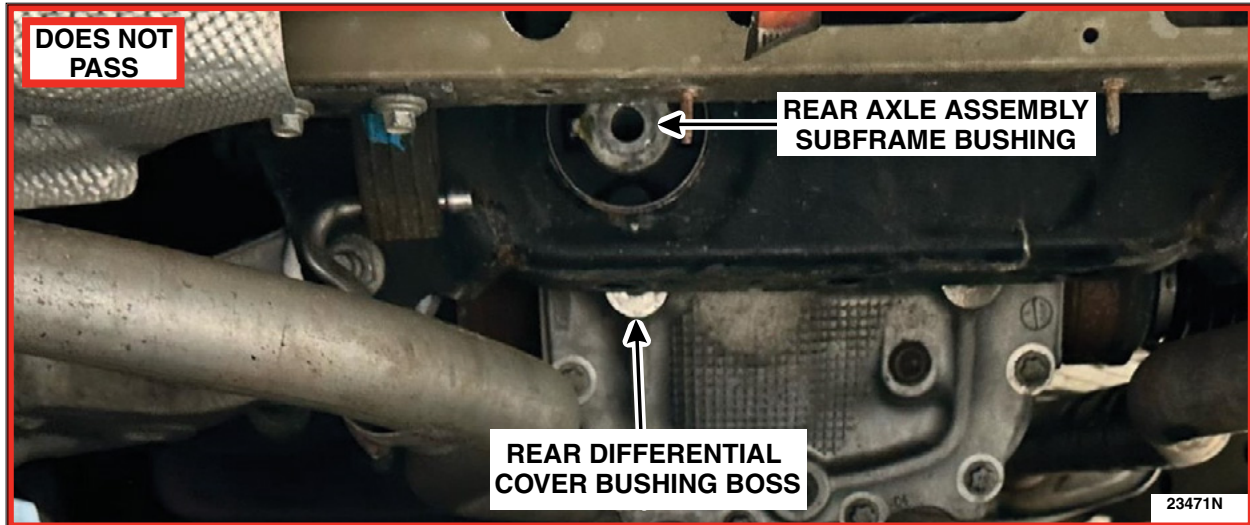

FIGURE 16

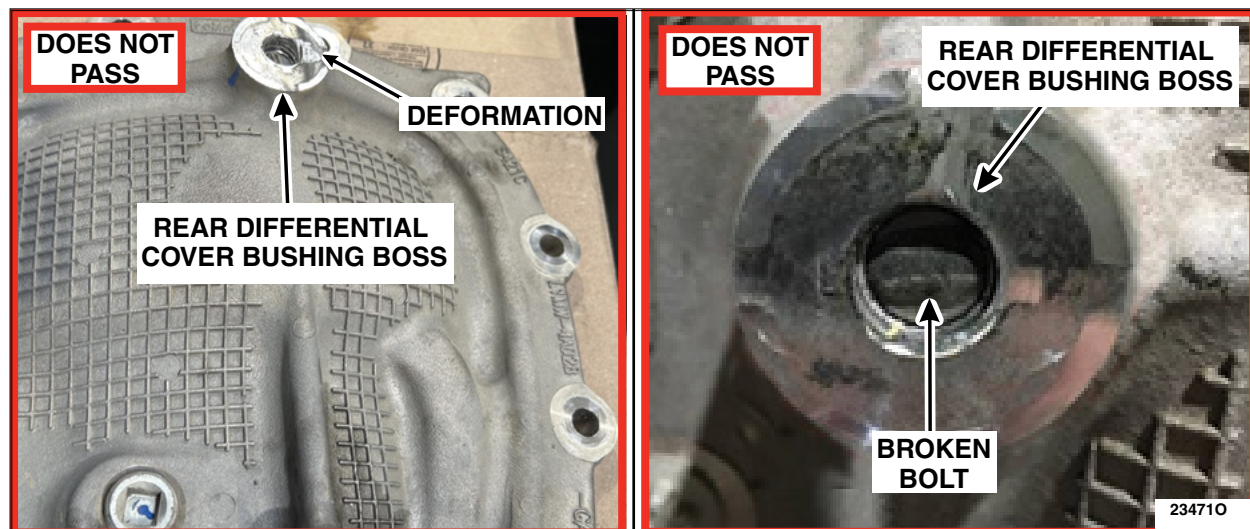

FIGURE 17



23. Using an M14 bolt ensure the threads of the rear differential cover bushing boss are not damaged. Can the M14 bolt be fully threaded in?

YES - Passes inspection. Proceed to Step 24.

NO - Does Not Pass inspection. Install only a *new* differential housing cover (Do Not install the rear axle assembly at this time). Follow the WSM procedures in Section 205-02. Proceed to Step 25.

24. Using a straight edge check to ensure the rear differential cover bushing boss is flat. Is the rear differential cover bushing boss flat?

YES - Passes inspection. Proceed to Step 25.

NO - Does Not Pass inspection. Install only a *new* differential housing cover (Do Not install the rear axle assembly at this time). Follow the WSM procedures in Section 205-02. Proceed to Step 25.

25. Using an 11/16 in. (18 mm) or larger drill bit, drill out the rear axle assembly subframe bushing hole. See Figure 18. Click on the video link to see the drilling process: [📺](#)

NOTE: The use of a corded, high power drill and a good quality/sharp drill bit along with the use of cutting oil will aid in drilling out the rear axle assembly subframe bushing hole.

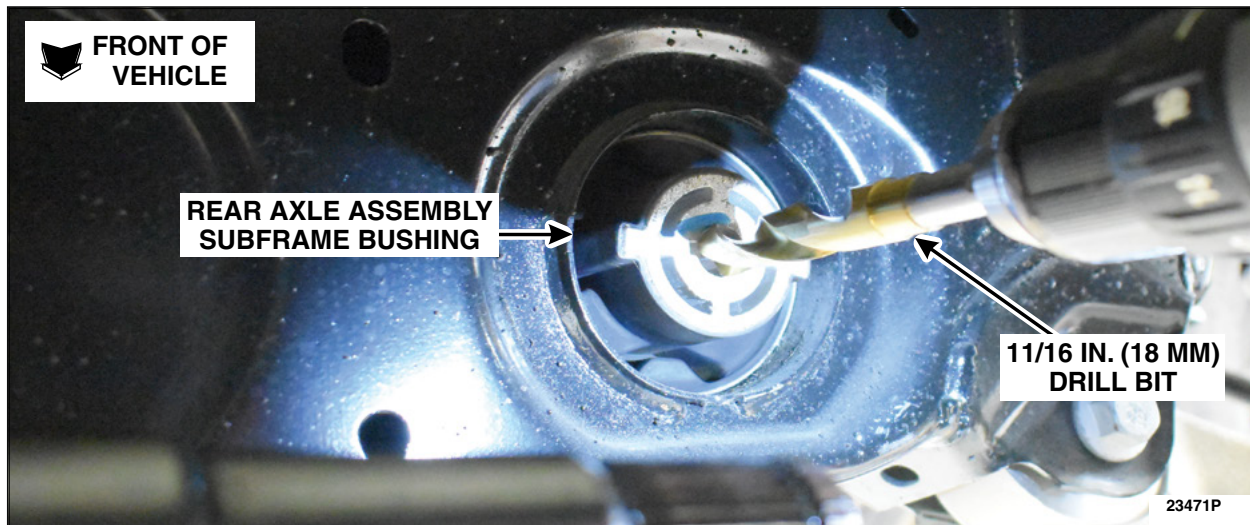

FIGURE 18



NOTE: Refer to the [Essential Special Service Tool \(ESST\) - Proper Inspection and Usage document](#), for recommended lubricant and proper use and orientation of the components within ESST 204-594.

NOTE: It is not recommended to use a smaller threaded rod as it could fail under the forces/load required.

NOTE: The use of longer wrenches will aid in the removal and installation of the rear axle assembly subframe bushing.

26. Using the ESST tools listed below, press out the rear axle assembly subframe bushing.
See Figure 19. Click on the video link to see the bushing removal process: [\[Video Link\]](#)

- 204-594 - Forcing Screw
- 204-356/1 - Remover/Installer, Radius Arm Axle Bushing
- 204-356/2 - Remover/Installer, Radius Arm Axle Bushing
- 307-739 - Installer, R3 Bearing
- 205-153 - Adapter, (Handle) for the 303-224 Installer

NOTE: The bearing, 307-739 Installer, R3 Bearing and 204-356/2 Remover/Installer, Radius Arm Axle Bushing go towards the front of the vehicle.

NOTE: The rear axle assembly subframe bushing will be pressed out towards the rear of the vehicle.

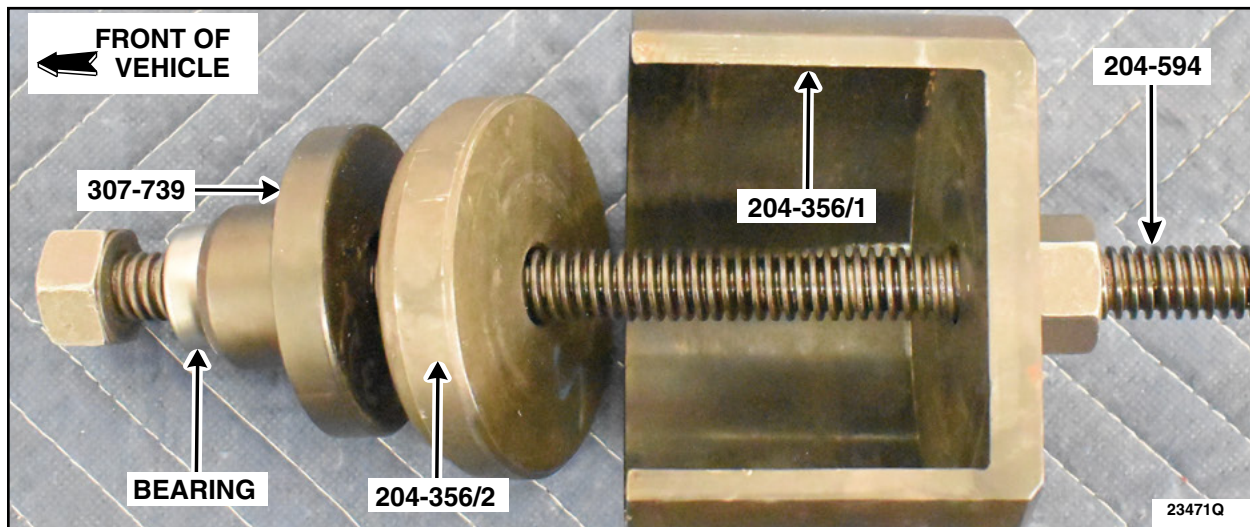

FIGURE 19



NOTE: Make sure the tabs on the *new* rear axle assembly subframe bushing are horizontal with the subframe. See Figure 20.

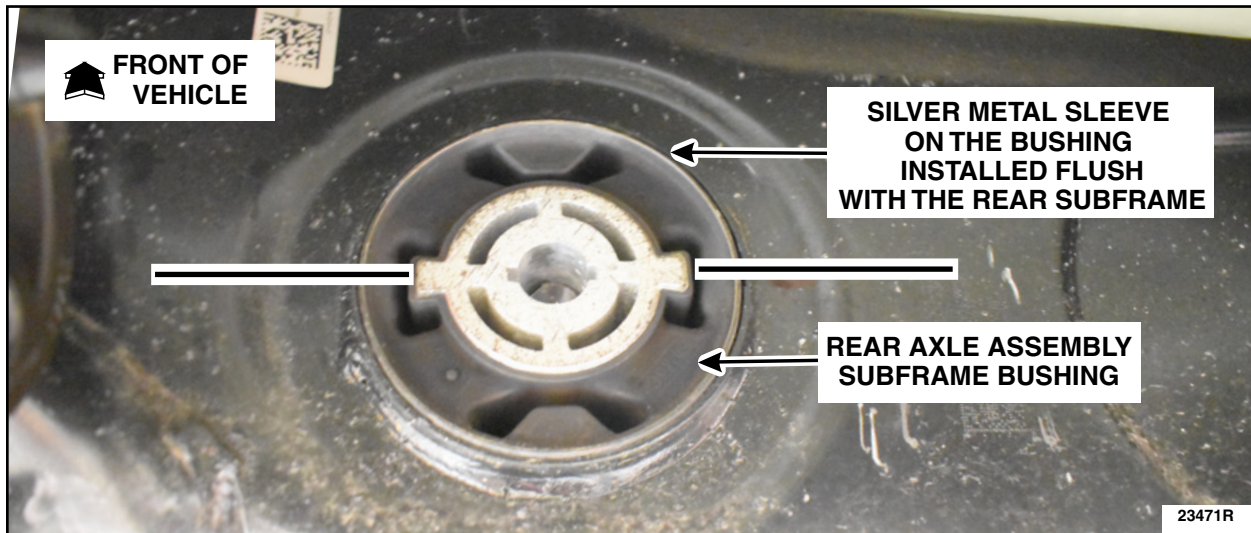

FIGURE 20

27. Using the ESST tools listed below, install the *new* rear axle assembly subframe bushing. See Figures 20 and 21.

- 204-594 - Forcing Screw
- 204-362/3 - Remover/Installer, Front Subframe Bushing
- 307-819 - Cup, Receiver

NOTE: The bearing and 307-819 Cup, Receiver, go towards the front of the vehicle.

NOTE: The *new* rear axle assembly subframe bushing will be pressed in from the rear of the vehicle.

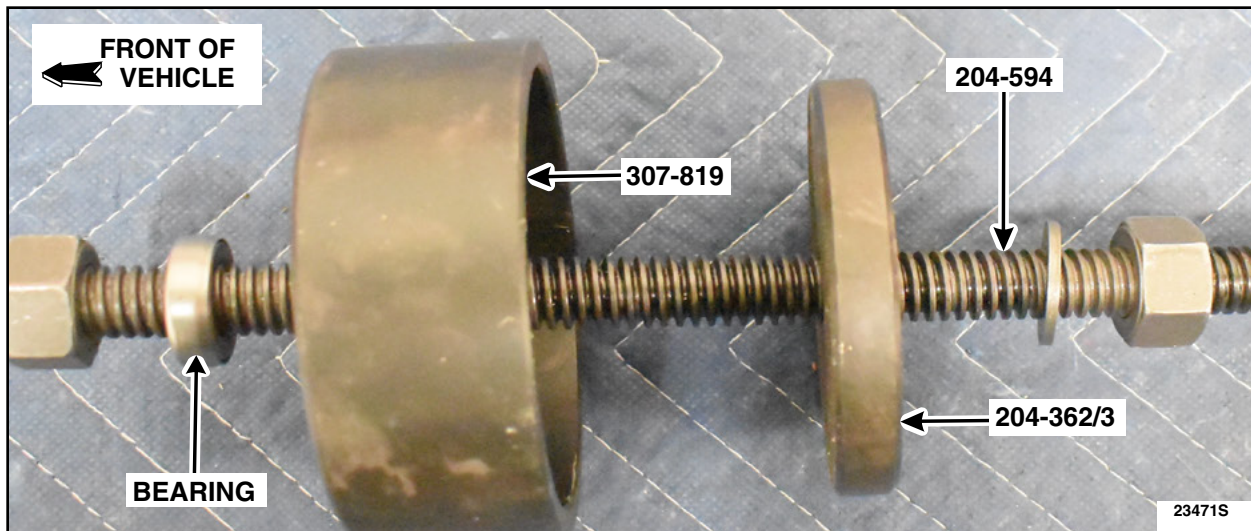

FIGURE 21



28. Replace both rear halfshaft seals. Follow the WSM procedures in Section 205-02.

- Use ESST 205-153, Handle and 307-758 Installer, Axle Seal.

NOTE: In the next Step, make sure both rear halfshaft circlip openings are located at the bottom or 6 o'clock position to allow for easy installation when directed to install them.

29. Remove and discard both rear inner halfshaft circlips. Then, install *new* circlips onto both rear inner halfshafts. See Figure 22. Then, proceed to the next Step.

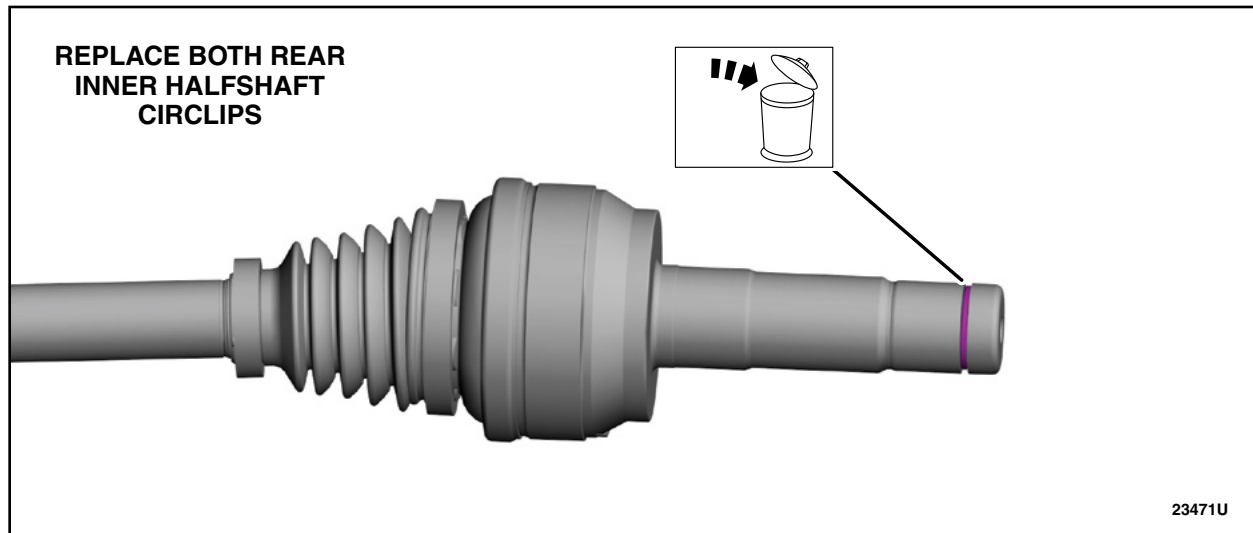

FIGURE 22

30. Reverse the removal steps, outlined in this procedure, to reinstall the rear differential housing assembly.

31. Using a jack stand set the ride high before torquing any suspension bolts.

32. Install the LH rear wheel and tire. Follow the WSM procedures in Section 204-04A.

33. Check and top off the rear differential fluid. Follow the WSM procedures in Section 205-02.

IMPORTANT NOTE: Federal law prohibits selling motor vehicle parts or components that are under safety, compliance, or emissions recall. Unless a part is requested to be returned to Ford, all parts replaced under this FSA must be scrapped in accordance with all applicable local, state and federal environmental protection and hazardous material regulations. Refer to the Parts Retention, Return, & Scrapping section of the FSA dealer bulletin for further information.



Safety Recall 23S55













Mobile Service Repair Assessment

Assessment levels have been identified to help determine the ease of performing eligible mobile service repairs for a Field Service Action (FSA) outside of the dealership service facility.

Dealer Bulletin



Within the Administrative Information Attachment of the dealer bulletin a mobile service repair assessment level(s) will be provided. These assessment levels have been determined using the amount of time, equipment and labor identified to perform the intended service action.

Assessment Levels

-  - Mobile Reprogramming
-   - Light Mobile Service
-    - Enhanced Mobile Service
-     - Advanced Mobile Service
-  - Wheel and Tire Mobile Service
-  - Not a Mobile Service Repair

Description of each level that is used to determine the overall assessment.

-  – Mobile Reprogramming
 - Module Programming or similar type services
 - Minimum tools maybe required other than an **IDS/FDRS** setup
 - FDRS programming that requires internet connection (wi-fi or mobile hotspot)
 - Make sure vehicle has a charge port to ensure battery voltage is maintained during flashing of the module(s)
 - Repairs not greater than 1 hour in length (including time to wait for programming)

Note: The location will need a charging station or wall box to maintain the 12-volt battery.
-   – Light Mobile Service
 - Interior repair procedures that do not require seat, dash, or headliner removal
 - Under hood repairs that do not require large component removal
 - Exterior repairs that do not require large component/panel removal
 - Repairs may require standard hand tools (Access to a Technician starter kit or similar)

Safety Recall 23S55

   – Enhanced Mobile Service

- ***A two-person process is required anytime a procedure requires work under the vehicle***
 - Brake Inspection and Brake Repair/Replacement
 - Limited Suspension Component replacement (no alignment)
 - Under Vehicle access for limited repairs (no large component removal)
 - Vehicle Check Up - VCU
 - Pre-Delivery Inspection - PDI
 - Used Car Inspection/Presale Inspection
 - May require floor jack, jack stands, and impact tools
- Note: Wheel lock may be required.*

    – Advanced Mobile Service

- Fluid Exchange/Oil Change
- Light Repairs
- Brake Hydraulic Repairs

 – Wheel and Tire Mobile Service

- Tire Removal from Wheel
- Tire Balancing
- Tire Repair

Note: Specialized Mobile Service unit and equipment including Tire balancer and Tire Changer required.

 – Not a Mobile Service Repair

- Large component removal
- BEV Battery Replacement
- Requires a vehicle hoist – to complete the repair (more than inspection)
- Required vehicle alignment
- Requires significant vehicle disassembly
- Repairs greater than 2-3 hours
- Any repairs that require M-Time
- Includes a service procedure where the vehicle owner may be distressed about the state of their vehicle

Safety Recall 23S55

Vehicle Pick-Up and Delivery Record

VIN _____ received (check one):

Pick-up and/or delivery service

As outlined below for the 23S55 Field Service Action program.

Pick-up – Date: _____

Delivery – Date: _____

Repair Order #

Repair Order Date

Service Manager Signature

Date

Ford Motor Company
Recall Reimbursement Plan for 23S55

Ford and Lincoln dealers are in the best position to quickly and efficiently process reimbursement requests. However, federal legislation requires all motor vehicle manufacturers to establish processes through which customers may seek recall reimbursement directly from the manufacturer or the dealers.

Regarding the specific reimbursement plan for Recall # 23S55, owners who have paid for service to remedy the defect or noncompliance must have had that service performed before January 31, 2025. After this date, if repairs related to this recall are performed by a non-Ford repair facility in an emergency, customers must submit any refund requests through their dealership. As required by this federal regulation, Ford Motor Company submitted the details of its latest General Recall Reimbursement Plan in a letter to the National Highway Traffic Safety Administration (NHTSA) in May 2021. The following is the text of that letter and the Plan:

General Recall Reimbursement Plan
(As submitted to the NHTSA)

Pursuant to the requirements set forth in 49 CFR Part 573 and Part 577 of the Code of Federal Regulations, Ford Motor Company (Ford) is submitting required information pertaining to our general reimbursement plan for the cost of remedies paid for by vehicle owners before they are notified of a related safety recall.

Set forth below is Ford's general plan to reimburse owners and purchasers for costs incurred for remedies in advance of notification of potential safety-related defects or noncompliances pursuant to Part 573.6 (c)(8)(i). This plan has not changed since our May 5, 2021 submission.

Reimbursement Notification

Ford's notice to a vehicle owner in accordance with 49 CFR Part 577 will indicate that Ford is offering a refund if the owner paid to have service to remedy the defect or noncompliance prior to a specified ending date. In accordance with Part 573.13 (c)(2), this ending date will be defined as a minimum of ten calendar days after the date on which Ford mailed the last of its Part 577 notifications to owners and will be indicated in the specific reimbursement plan available to owners for an individual recall. This notice will direct owners to seek eligible reimbursement through authorized dealers or, at their option, directly through Ford at the following address:

Ford Motor Company
P.O. Box 6251
Dearborn, MI 48121-6251

Ford notes that this rule allows for the identification of a beginning date for reimbursement eligibility. Under the rule, an owner who paid to remedy the defect or noncompliance prior to the identified beginning date would not be eligible for reimbursement. Ford generally has not established such a beginning date for reimbursement eligibility and does not presently anticipate changing this general policy. However, in any case where Ford determines a beginning date is appropriate, Ford will indicate that date in the owner notice. As permitted by 577.11(e), Ford may not include a

reimbursement notification when all vehicles are well within the warranty period, subject to approval by the Agency.

Costs to be Reimbursed

For vehicles, reimbursement will not be less than the lesser of:

- The amount paid by the owner for the remedy that specifically addressed and was reasonably necessary to correct the defect or noncompliance that is the subject of the recall, or
- The cost of parts for the remedy (to be no more than the manufacturer's list retail price for authorized part(s), plus associated labor at local labor rates, miscellaneous fees (such as disposal of waste) and taxes.

For replacement equipment, reimbursement will be the amount paid by the owner for the replacement item (limited by the amount of the retail list price of the defective or noncompliant item that was replaced, plus taxes, where the brand or model purchased by the owner was different than the brand or model that was the subject of the recall). If the item of motor vehicle equipment was repaired, the reimbursement provisions identified above for vehicles will apply.

Ford notes that costs incurred by the owner within the period during which Ford's original or extended warranty would have provided for a free repair of the problem will not be eligible for reimbursement, as provided by Part 573.13 (d)(1).

Entities Authorized to Provide Reimbursement

Ford will continue to use authorized dealers to reimburse owners under the specific reimbursement plans for a particular recall and will encourage owners to pursue requests for reimbursement directly through dealers to expedite reimbursement. Ford will also provide a mailing address to which customers can, at their option, send requests for reimbursement directly to Ford, as previously noted. Requests for reimbursement sent directly to Ford may take up to 60 days to process. Whether the owner chooses to pursue reimbursement requests through a dealer or directly through Ford, the owner will be directed to submit the required documentation, upon which reimbursement eligibility will be determined.

Required Documentation

The reimbursement determination will depend upon the information provided by the customer. Consistent with Part 573.13 (d)(4) the following information must be submitted:

- Claimant name and address
- Vehicle make, model and model year
- Vehicle identification number (VIN) and, for replacement equipment, a description of such equipment or, for tires, the model, size and TIN (DOT code)
- Identification of the recall number (either the Ford recall number or the NHTSA recall number)
- Identification of the owner of the recalled vehicle at the time that the pre-notification remedy was obtained
- An original receipt for the pre-notification remedy that includes a breakdown of the amount for parts, labor, other costs and taxes, including costs for the replacement item. Where the receipt covers work other than to address the recall or noncompliance, Ford may require the claimant to separately identify costs that are eligible for reimbursement.

- If the remedy was obtained during the warranty repair did not correct the problem related to the recall

Failure to submit all the above information may result in denial of the reimbursement request.

Additional Information

The Part 577 required owner notice will provide a toll-free telephone number through which specific information about the reimbursement plan can be requested from Ford. This general reimbursement plan will be incorporated into notifications pursuant to Part 573.6 by reference. Information specific to an individual recall also may be incorporated into the Part 573.6 notification.