

December 2023
FL980A-D
NHTSA #23V-537
Transport Canada #2023-422

Subject: Driveshaft

Models Affected: Specific model years 2023 Freightliner M2 vehicles manufactured between September 13, 2022, through October 11, 2022.

General Information

Daimler Truck North America LLC (DTNA), on behalf of its Freightliner Truck Division, has decided that a defect that relates to motor vehicle safety exists on the vehicles mentioned above.

On the affected vehicles, due to a sub-supplier's use of non-conforming material, the driveshafts can break in certain loading conditions. A broken driveshaft can separate and cause the loss of drive power, increasing the risk of a crash.

A Daimler Truck North America authorized service facility will replace the driveshaft. The repair will take approximately two hours and will be performed free of charge.

There are approximately 208 vehicles involved in this campaign.

Additional Repairs

Dealers must complete all outstanding recall and field service campaigns prior to the sale or delivery of a vehicle. A dealer will be liable for any progressive damage that results from its failure to complete campaigns before sale or delivery of a vehicle.

Owners may be liable for any progressive damage that results from failure to complete campaigns within a reasonable time after receiving notification.

Work Instructions

Please refer to the attached work instructions. Prior to performing the campaign, check the vehicle for a completion sticker (Form WAR260).

Replacement Parts

Inspection must be performed before ordering parts. Replacement parts are now available. To locate the correct driveline enter the Recalled chassis VIN into Excelerator to determine driveline part number. Order replacement parts from your Parts Distribution Center.

If our records show your dealership has ordered any vehicle(s) involved in campaign number FL980, a list of the customers and vehicle identification numbers will be available on the DTNA Portal. Please refer to this list when ordering parts for this recall.

Removed Parts

U.S. and Canadian Dealers, please follow Warranty Failed Parts Tracking shipping instructions for the disposition of all removed parts. Export distributors, please destroy removed parts unless otherwise advised.

Labor Allowance

Table 1 - Labor Allowance

Campaign Number	Procedure	Time Allowed (hours)	SRT Code	Corrective Action
FL980A-D	Inspect Driveline	0.5	996-R217A	06-Inspect
FL980A-D	Inspect up to four drivelines; remove and replace one driveline	1.0	996-R217B	12-Repair Recall/Campaign

Table 1 continued on page 2.

December 2023
FL980A-D
NHTSA #23V-537
Transport Canada #2023-422

Campaign Number	Procedure	Time Allowed (hours)	SRT Code	Corrective Action
FL980A-D	Remove and replace one additional driveline	0.5	996-R217F	12-Repair Recall/Campaign

continued from page 1.

IMPORTANT:When the recall has been completed, locate the base completion label in the appropriate location on the vehicle, and attach the red completion sticker provided in the recall kit (Form WAR260). If the vehicle does not have a base completion label, clean a spot on the appropriate location of the vehicle and first attach the base completion label (Form WAR259). If a recall kit is not required or there is no completion sticker in the kit, write the recall number on a blank sticker and attach it to the base completion label.

Claims for Credit

You will be reimbursed for your parts, labor, and handling (landed cost for Export Distributors) by submitting your claim through the warranty system within 30 days of completing this campaign. Please reference the following information in OWL:

- Claim type is **Recall Campaign**.
- In the Campaign field, enter the campaign number and appropriate condition code (e.g. **FL980-A, FL980-B, etc.**).
- In the Primary Failed Part Number field, enter **25-FL980-000**.
- In the Parts field, enter the appropriate kit or part number(s) as shown in the Replacement Parts table.
- In the Labor field, first enter the appropriate SRT from the Labor Allowance table. Administrative time will be included automatically as SRT 939-6010A for 0.3 hours.
- The VMRS Component Code is **F99-999-005** and the Cause Code is **A1 - Campaign**.
- **U.S. and Canada -- Reimbursement for Prior Repairs.** When a customer asks about reimbursement, please do the following:
 - Accept the documentation of the previous repair.
 - Make a brief check of the customer's paperwork to see if the repair may be eligible for reimbursement. (See the "Copy of Owner Letter" section of this bulletin for reimbursement guidelines.)
 - Submit an OWL Recall Pre-Approval request for a decision.
 - Include the approved amount on your claim in the Other Charges section.
 - Attach the documentation to the pre-approval request.
 - If approved, submit a based-on claim for the pre-approval.
 - Reimburse the customer the appropriate amount.

IMPORTANT: OWL must be viewed prior to performing the recall to ensure the vehicle is involved and the campaign has not been previously completed. Also, check for a completion sticker prior to beginning work.

U.S. and Canadian dealers, if you need additional information, contact the Warranty Campaigns Department using the WSC (Warranty Support Center) app on the DTNA Portal. Export distributors, submit a WSC ticket or contact your International Service Manager.

U.S. and Canadian Dealers: To return excess kit inventory related to this campaign, U.S. dealers must submit a Parts Authorization Return (PAR) to the Memphis PDC. Canadian dealers must submit a PAR to their facing PDC. All kits must be in resalable condition. PAR requests must include the original purchase invoice number. Export Distributors: Excess inventory is not returnable.

The letter notifying U.S. and Canadian vehicle owners is included for your reference.

**December 2023
FL980A-D
NHTSA #23V-537
Transport Canada #2023-422**

Please note that the National Traffic and Motor Vehicle Safety Act, as amended (Title 49, United States Code, Chapter 301), requires the owner's vehicle(s) be corrected within a reasonable time after parts are available to you. The Act states that failure to repair a vehicle within 60 days after tender for repair shall be prima facie evidence of an unreasonable time. However, circumstances of a particular situation may reduce the 60 day period. Failure to repair a vehicle within a reasonable time can result in either the obligation to (a) replace the vehicle with an identical or reasonably equivalent vehicle, without charge, or (b) refund the purchase price in full, less a reasonable allowance for depreciation. The Act further prohibits dealers from selling a vehicle unless all outstanding recalls are performed. Any lessor is required to send a copy of the recall notification to the lessee within 10 days. Any subsequent stage manufacturer is required to forward this notice to its distributors and retail outlets within five working days.

December 2023
FL980
Transport Canada #2023-422

Copy of Notice to Owners

Subject: Driveshaft

For the Notice to U.S. Customers: This notice is sent to you in accordance with the National Traffic and Motor Vehicle Safety Act. **For the Notice to Canadian Customers:** This notice is sent to you in accordance with the requirements of the Motor Vehicle Safety Act. This is to inform you that your vehicle may contain a defect that could affect the safety of a person.

Daimler Truck North America LLC (DTNA), on behalf of its Freightliner Truck Division has decided that a defect, which relates to motor vehicle safety, exists in certain 2023 Freightliner M2 vehicles manufactured September 22, 2022, through September 26, 2022.

On the affected vehicles, due to a sub-supplier's use of non-conforming material, the driveshafts can break in certain loading conditions. A broken driveshaft can separate and cause the loss of drive power, increasing the risk of a crash.

A Daimler Truck North America authorized service facility will replace the driveshaft. The repair will take approximately two hours and will be performed free of charge.

Please contact an authorized Daimler Truck North America dealer to arrange to have the Recall performed and to ensure that parts are available at the dealership. To locate an authorized dealer, search online at <https://northamerica.daimlertruck.com/contact-us>. Scroll down to "Locate a Dealer" and select the appropriate brand. You may also confirm your vehicle's involvement in this recall at the following URL: <https://dtna-dlinfo.prd.freightliner.com:48518/VinLookup/vin-module/getVinLookupPage>.

You may be liable for any progressive damage that results from your failure to complete the recall within a reasonable time after receiving notification.

If you do not own the vehicle that corresponds to the identification number(s) which appears on the Recall Notification, please return the notification to the Warranty Campaigns Department with any information you can furnish that will assist us in locating the present owner. If you have leased this vehicle, Federal law requires that you forward this notice to the lessee within 10 days. If you are a subsequent stage manufacturer, Federal law requires that you forward this notice to your distributors and retail outlets within five working days.

If you have questions about this Recall, please contact the Warranty Campaigns Department at (800) 547-0712, 7:00 a.m. to 4:00 p.m. Pacific Time, Monday through Friday, e-mail address DTNA.Warranty.Campaigns@Daimlertruck.com. For other concerns, you may contact the Customer Assistance Center at (800) 385-4357. If you have a safety concern relating to this Recall, you may wish to contact Transport Canada – Motor Vehicle Safety at, 80 rue Noel, Gatineau, Quebec J8Z 0A1 or phone (800) 333-0510.

We regret any inconvenience this action may cause but feel certain you understand our interest in motor vehicle safety.

WARRANTY CAMPAIGNS DEPARTMENT

Enclosure

December 2023
FL980
NHTSA #23V-537

Copy of Notice to Owners

Subject: Driveshaft

For the Notice to U.S. Customers: This notice is sent to you in accordance with the National Traffic and Motor Vehicle Safety Act. **For the Notice to Canadian Customers:** This notice is sent to you in accordance with the requirements of the Motor Vehicle Safety Act. This is to inform you that your vehicle may contain a defect that could affect the safety of a person.

Daimler Truck North America LLC (DTNA), on behalf of its Freightliner Truck Division has decided that a defect, which relates to motor vehicle safety, exists in certain 2023 Freightliner M2 vehicles manufactured September 13, 2022, through October 11, 2022.

On the affected vehicles, due to a sub-supplier's use of non-conforming material, the driveshafts can break in certain loading conditions. A broken driveshaft can separate and cause the loss of drive power, increasing the risk of a crash.

A Daimler Truck North America authorized service facility will replace the driveshaft. The repair will take approximately two hours and will be performed free of charge.

Please contact an authorized Daimler Truck North America dealer to arrange to have the Recall performed and to ensure that parts are available at the dealership. To locate an authorized dealer, search online at <https://northamerica.daimlertruck.com/contact-us>. Scroll down to "Locate a Dealer" and select the appropriate brand. You may also confirm your vehicle's involvement in this recall at the following URL: <https://dtna-dlinfo.prd.freightliner.com:48518/VinLookup/vin-module/getVinLookupPage>.

You may be liable for any progressive damage that results from your failure to complete the recall within a reasonable time after receiving notification.

If you do not own the vehicle that corresponds to the identification number(s) which appears on the Recall Notification, please return the notification to the Warranty Campaigns Department with any information you can furnish that will assist us in locating the present owner. If you have leased this vehicle, Federal law requires that you forward this notice to the lessee within 10 days. If you are a subsequent stage manufacturer, Federal law requires that you forward this notice to your distributors and retail outlets within five working days. If you have paid to have this recall condition corrected prior to this notice, you may be eligible to receive reimbursement. Please see the reverse side of this notice for details.

If you have questions about this Recall, please contact the Warranty Campaigns Department at (800) 547-0712, 7:00 a.m. to 4:00 p.m. Pacific Time, Monday through Friday, e-mail address DTNA.Warranty.Campaigns@Daimlertruck.com. For other concerns, you may contact the Customer Assistance Center at (800) 385-4357. If your manufacturer, distributor, or dealer fails to remedy the defect or noncompliance without charge and within a reasonable time, you may wish to submit a complaint to the Administrator, National Highway Traffic Safety Administration, 1200 New Jersey Avenue SE, Washington, DC 20590; or call the Vehicle Safety Hotline at (888) 327-4236 (TTY: 800-424-9153); or go to <http://www.nhtsa.gov>.

We regret any inconvenience this action may cause but feel certain you understand our interest in motor vehicle safety.

WARRANTY CAMPAIGNS DEPARTMENT

Enclosure

**December 2023
FL980
NHTSA #23V-537**

Reimbursement to Customers for Repairs Performed Prior to Recall

If you have already **paid** to have this recall condition corrected you may be eligible to receive reimbursement.

Requests for reimbursement may include parts and labor. Reimbursement may be limited to the amount the repair would have cost if completed by an authorized Daimler Truck North America LLC dealer. The following documentation must be presented to your dealer for consideration for reimbursement.

Please provide original or clear copies of all receipts, invoices, and repair orders that show:

- The name and address of the person who paid for the repair
- The Vehicle Identification Number (VIN) of the vehicle that was repaired
- What problem occurred, what repair was done, when the repair was done
- Who repaired the vehicle
- The total cost of the repair expense that is being claimed
- Proof of payment for the repair (such as the front and back of a cancelled check or a credit card receipt)

Reimbursement will be made by check from your Daimler Truck North America LLC dealer.

Please speak with your Daimler Truck North America LLC authorized dealer concerning this matter.

December 2023
FL980A-D
NHTSA #23V-537
Transport Canada #2023-422

Work Instructions

Subject: Driveshaft

Models Affected: Specific model years 2023 Freightliner M2 vehicles manufactured between September 13, 2022, through October 11, 2022.

Driveline Inspection

IMPORTANT: Inspection must be performed before ordering parts. Replacement parts are now available. To locate the correct driveline enter the Recalled chassis VIN into Exceleator to determine driveline part number. Order replacement parts from your Parts Distribution Center.

1. Check the base label (Form WAR259) for a completion sticker for FL980 (Form WAR260) indicating this work has been done. The base label is usually located on the passenger-side door, about 12 inches (30 cm) below the door latch. If a recall completion sticker is present, no work is needed. If there is no sticker, proceed with the next step.
2. Park the vehicle on a level surface, shut down the engine, and set the parking brake. Chock the tires.
3. Inspect all the driveshafts except the last driveshaft that connects to the rear axle. See [Fig. 1](#) for the driveshafts to be inspected.

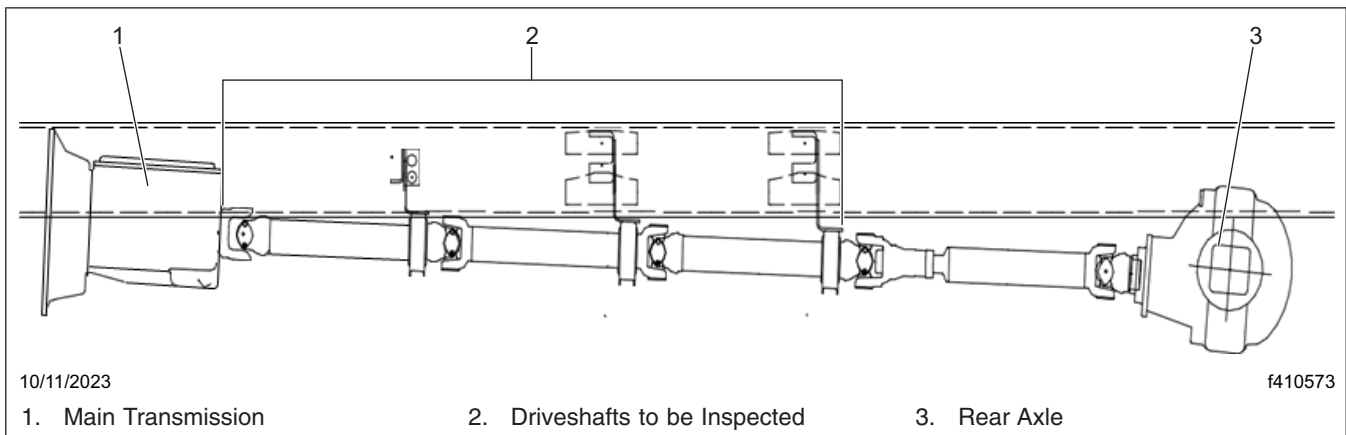

Fig. 1, Driveshafts to Inspect

December 2023
FL980A-D
NHTSA #23V-537
Transport Canada #2023-422

4. Locate the label in the center of each driveshaft on the vehicle. It may be covered with paint, tape, or a clear protective cover. Remove those to expose the Dana driveshaft label. **Figure 2** shows the location of the label.
5. Find the Dana serial number and the job set number. Replace the driveshaft if the serial number is between **R0009761049** and **R0009762909**, and the job set number is either 929 or 931. **Figure 3** shows the location of the serial number and the job set number.



Fig. 2, Location of the Driveshaft Label

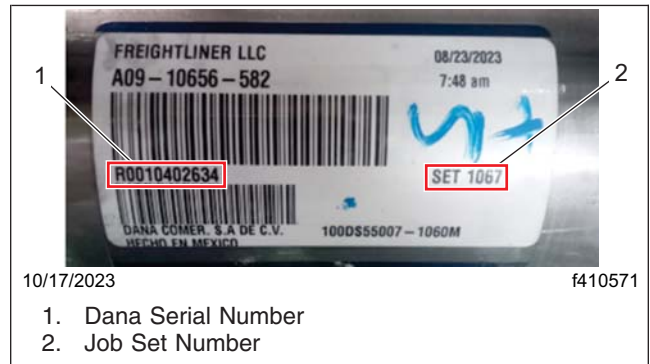

Fig. 3, Location of the Serial Number and the Job Set Number

6. Repeat the inspection procedure on all the driveshafts except the main axle that is connected to the rear axle.

Driveline Replacement

1. For driveshafts replacement, see **Group 41** of the *Business Class M2 Workshop Manual*.
2. Replace all the driveshafts that were identified to be replaced during the inspection procedure.
3. Clean a spot on the base label (Form WAR259), and attach a recall completion sticker for FL980 (Form WAR260), indicating this work has been completed.