

December 2023  
FL979A-F  
NHTSA #23V-467  
Transport Canada #2023-372  
REVISED (May 2024)

## **Subject: Freightliner eCascadia e-Axle Ring Gear**

**Models Affected: Specific model years 2023-2024 Freightliner eCascadia vehicles manufactured between January 19, 2023, through April 13, 2023.**

### **General Information**

Daimler Truck North America LLC (DTNA), on behalf of its Freightliner Trucks Division, has decided that a defect that relates to motor vehicle safety exists on the vehicles mentioned above.

**NEW REVISION:** The Labor Allowance table has been revised due to incorrect application of SRTs to respective groups, resulting in the omission of time for road tests, alignments, or time required to paint the axles when necessary. Additionally, certain steps have been added to the work instructions, while others have been rearranged to enhance clarity.

**REVISION:** The Parts table has been revised to incorporate the High Voltage (HV) flange gasket for the rear tandem e-axle. Additionally, the Work Instructions have been updated to include supplementary information on handling the e-axle being shipped in the neutral position.

On the affected vehicles, the e-axle planetary gear set(s) may not be welded properly, which can cause the e-motor to detach from the final drive. This may result in an undetectable, sudden loss of drive power without the ability to restart the vehicle, which can increase the risk of a crash.

A Daimler Truck North America authorized service facility will replace the e-axle(s) on your vehicle. The Recall will take approximately eleven hours and will be performed free of charge.

There are approximately 95 vehicles involved in this campaign.

### **Additional Repairs**

Dealers must complete all outstanding recall and field service campaigns prior to the sale or delivery of a vehicle. A dealer will be liable for any progressive damage that results from its failure to complete campaigns before sale or delivery of a vehicle.

Owners may be liable for any progressive damage that results from failure to complete campaigns within a reasonable time after receiving notification.

### **Work Instructions**

Please refer to the attached work instructions. Prior to performing the campaign, check the vehicle for a completion sticker (Form WAR260).

### **Replacement Parts**

Replacement parts are now available and can be obtained by ordering the kit and/or part number(s) listed below from your facing Parts Distribution Center (PDC).

If our records show your dealership has ordered any vehicle(s) involved in campaign number FL979, a list of the customers and vehicle identification numbers will be available on the DTNA Portal. Please refer to this list when ordering parts for this recall.

**December 2023  
FL979A-F  
NHTSA #23V-467  
Transport Canada #2023-372  
REVISED (May 2024)**

**Table 1** - Replacement Parts for FL979

<b>Campaign Number</b>	<b>Part Description</b>	<b>Part Number</b>	<b>Qty.</b>
FL979A	e-AXLE, REAR AXLE, 4X2 NON-DCDL	MBA 7753509214	1 ea
	U-BOLT	23-14198-371	4 ea
FL979BC	e-AXLE, REAR 1ST AXLE, 6X4 NON-DCDL	MBA 7753508914	1 ea
FL979D	e-AXLE, REAR 1ST AXLE, 6X4 DCDL	MBA 7753509014	1 ea
FL979EF	e-AXLE, REAR 2ND AXLE, 6X4 NON-DCDL	MBA 7753508814	1 ea
	FLANGE GASKET	MBA 7753530680	
FL979A-F	U-BOLT	11-23853-002	4 ea
	U-BOLT WASHER	23-09114-005	8 ea
	U-BOLT NUT	23-00461-007	8 ea
	WHEEL SEAL	CM 10045887	2 ea
	AXLE SHAFT O-RING	11-30728-000	2 ea
	CALIPER BOLTS	N210931 020001	12 ea
	CALIPER WASHER	23-09114-004	12 ea
	SPIDER PLATE BOLT - 2"	23-09445-200	16 ea
	SPIDER PLATE BOLT - 2.5"	23-09445-250	4 ea
	SPIDER PLATE WASHER	WWS 2W0264879	40 ea
FL979E-F	FLANGE GASKET	MBA 7753530680	1 ea
FL979A-F	BLANK COMPLETION STICKER	WAR260	1 ea

**Table 1**

**Removed Parts**

U.S. and Canadian Dealers, please follow Warranty Failed Parts Tracking shipping instructions for the disposition of all removed parts. Export distributors, please destroy removed parts unless otherwise advised.

**Labor Allowance**

**Table 2** - Labor Allowance

<b>Campaign Number</b>	<b>Procedure</b>	<b>Time Allowed (hours)</b>	<b>SRT Code</b>	<b>Corrective Action</b>
FL979A	Axle, Electric, Single or Front Tandem, R/R	14.2	996-R218A	12-Repair Recall/Campaign
FL979B-D	Axle, Electric, Rear Tandem, R/R	14.6	996-R218B	12-Repair Recall/Campaign
FL979E-F	Axle, Electric, Rear Tandem, Additional R/R	12.2	996-R218C	12-Repair Recall/Campaign

**Table 2**

**IMPORTANT:**When the recall has been completed, locate the base completion label in the appropriate location on the vehicle, and attach the red completion sticker provided in the recall kit (Form WAR260). If the vehicle does not have a base completion label, clean a spot on the appropriate location of the vehicle and first attach the base completion label (Form WAR259). If a recall kit is not required or there is no completion sticker in the kit, write the recall number on a blank sticker and attach it to the base completion label.

**Claims for Credit**

You will be reimbursed for your parts, labor, and handling (landed cost for Export Distributors) by submitting your claim through the warranty system within 30 days of completing this campaign. Please reference the following information in OWL:

**December 2023  
FL979A-F  
NHTSA #23V-467  
Transport Canada #2023-372  
REVISED (May 2024)**

- Claim type is **Recall Campaign**.
- In the Campaign field, enter the campaign number and appropriate condition code (**FL979-A, FL979-B, etc.**).
- In the Primary Failed Part Number field, enter **25-FL979-000**.
- In the Parts field, enter the appropriate kit or part number(s) as shown in the Replacement Parts table.
- In the Labor field, first enter the appropriate SRT from the Labor Allowance table. Administrative time will be included automatically as SRT 939-6010A for 0.3 hours.
- The VMRS Component Code is **F99-999-005** and the Cause Code is **A1 - Campaign**.
- **U.S. and Canada — Reimbursement for Prior Repairs.** When a customer asks about reimbursement, please do the following:
  - Accept the documentation of the previous repair.
  - Make a brief check of the customer's paperwork to see if the repair may be eligible for reimbursement. (See the "Copy of Owner Letter" section of this bulletin for reimbursement guidelines.)
  - Submit an OWL Recall Pre-Approval request for a decision.
  - Include the approved amount on your claim in the Other Charges section.
  - Attach the documentation to the pre-approval request.
  - If approved, submit a based-on claim for the pre-approval.
  - Reimburse the customer the appropriate amount.

**IMPORTANT:** OWL must be viewed prior to performing the recall to ensure the vehicle is involved and the campaign has not been previously completed. Also, check for a completion sticker prior to beginning work.

U.S. and Canadian dealers, if you need additional information, contact the Warranty Campaigns Department using the WSC (Warranty Support Center) app on the DTNA Portal. Export distributors, submit a WSC ticket or contact your International Service Manager.

U.S. and Canadian Dealers: To return excess kit inventory related to this campaign, U.S. dealers must submit a Parts Authorization Return (PAR) to the Memphis PDC. Canadian dealers must submit a PAR to their facing PDC. All kits must be in resalable condition. PAR requests must include the original purchase invoice number. Export Distributors: Excess inventory is not returnable.

The letter notifying U.S. and Canadian vehicle owners is included for your reference.

Please note that the National Traffic and Motor Vehicle Safety Act, as amended (Title 49, United States Code, Chapter 301), requires the owner's vehicle(s) be corrected within a reasonable time after parts are available to you. The Act states that failure to repair a vehicle within 60 days after tender for repair shall be prima facie evidence of an unreasonable time. However, circumstances of a particular situation may reduce the 60 day period. Failure to repair a vehicle within a reasonable time can result in either the obligation to (a) replace the vehicle with an identical or reasonably equivalent vehicle, without charge, or (b) refund the purchase price in full, less a reasonable allowance for depreciation. The Act further prohibits dealers from selling a vehicle unless all outstanding recalls are performed. Any lessor is required to send a copy of the recall notification to the lessee within 10 days. Any subsequent stage manufacturer is required to forward this notice to its distributors and retail outlets within five working days.

**December 2023  
FL979A-F  
NHTSA #23V-467  
Transport Canada #2023-372  
REVISED (May 2024)**

## **Copy of Notice to Owners**

### **Subject: Freightliner eCascadia e-Axle Ring Gear**

This notice is sent to you in accordance with the requirements of the Motor Vehicle Safety Act. This is to inform you that your vehicle may contain a defect that could affect the safety of a person.

Daimler Truck North America LLC (DTNA), on behalf of its Freightliner Trucks Division, has decided that a defect, which relates to motor vehicle safety, exists in certain 2024 Freightliner eCascadia vehicles manufactured between January 31, 2023, through April 12, 2023.

On the affected vehicles, the e-axle planetary gear set(s) may not be welded properly, which can cause the e-motor to detach from the final drive. This may result in an undetectable, sudden loss of drive power without the ability to restart the vehicle, which can increase the risk of a crash.

A Daimler Truck North America authorized service facility will replace the e-axle(s) on your vehicle. The Recall will take approximately eleven hours and will be performed free of charge.

Please contact an authorized Daimler Truck North America dealer to arrange to have the Recall performed and to ensure that parts are available at the dealership. To locate an authorized dealer, search online at <https://northamerica.daimlertruck.com/contact-us>. Scroll down to "Locate a Dealer" and select the appropriate brand. You may also confirm your vehicle's involvement in this recall at the following URL: <https://dtna-dlrinfo.prd.freightliner.com:48518/VinLookup/vin-module/getVinLookupPage>.

You may be liable for any progressive damage that results from your failure to complete the recall within a reasonable time after receiving notification.

If you do not own the vehicle that corresponds to the identification number(s) which appears on the Recall Notification, please return the notification to the Warranty Campaigns Department with any information you can furnish that will assist us in locating the present owner. If you have leased this vehicle, Federal law requires that you forward this notice to the lessee within 10 days. If you are a subsequent stage manufacturer, Federal law requires that you forward this notice to your distributors and retail outlets within five working days.

If you have questions about this Recall, please contact the Warranty Campaigns Department at (800) 547-0712, 7:00 a.m. to 4:00 p.m. Pacific Time, Monday through Friday, e-mail address [DTNA.Warranty.Campaigns@Daimlertruck.com](mailto:DTNA.Warranty.Campaigns@Daimlertruck.com). For other concerns, you may contact the Customer Assistance Center at (800) 385-4357. If you have a safety concern relating to this Recall, you may wish to contact Transport Canada – Motor Vehicle Safety at, 80 rue Noel, Gatineau, Quebec J8Z 0A1 or phone (800) 333-0510.

We regret any inconvenience this action may cause but feel certain you understand our interest in motor vehicle safety.

WARRANTY CAMPAIGNS DEPARTMENT

Enclosure

December 2023  
FL979A-F  
NHTSA #23V-467  
Transport Canada #2023-372  
REVISED (May 2024)

## Copy of Notice to Owners

### Subject: Freightliner eCascadia e-Axle Ring Gear

This notice is sent to you in accordance with the National Traffic and Motor Vehicle Safety Act.

Daimler Truck North America LLC (DTNA), on behalf of its Freightliner Trucks Division, has decided that a defect, which relates to motor vehicle safety, exists in certain 2023-2024 Freightliner eCascadia vehicles manufactured between January 19, 2023, through April 13, 2023.

On the affected vehicles, the e-axle planetary gear set(s) may not be welded properly, which can cause the e-motor to detach from the final drive. This may result in an undetectable, sudden loss of drive power without the ability to restart the vehicle, which can increase the risk of a crash.

A Daimler Truck North America authorized service facility will replace the e-axle(s) on your vehicle. The Recall will take approximately eleven hours and will be performed free of charge.

Please contact an authorized Daimler Truck North America dealer to arrange to have the Recall performed and to ensure that parts are available at the dealership. To locate an authorized dealer, search online at <https://northamerica.daimlertruck.com/contact-us>. Scroll down to "Locate a Dealer" and select the appropriate brand. You may also confirm your vehicle's involvement in this recall at the following URL: <https://dtna-dlrinfo.prd.freightliner.com:48518/VinLookup/vin-module/getVinLookupPage>.

You may be liable for any progressive damage that results from your failure to complete the recall within a reasonable time after receiving notification.

If you do not own the vehicle that corresponds to the identification number(s) which appears on the Recall Notification, please return the notification to the Warranty Campaigns Department with any information you can furnish that will assist us in locating the present owner. If you have leased this vehicle, Federal law requires that you forward this notice to the lessee within 10 days. If you are a subsequent stage manufacturer, Federal law requires that you forward this notice to your distributors and retail outlets within five working days. If you have paid to have this recall condition corrected prior to this notice, you may be eligible to receive reimbursement. Please see the reverse side of this notice for details.

If you have questions about this Recall, please contact the Warranty Campaigns Department at (800) 547-0712, 7:00 a.m. to 4:00 p.m. Pacific Time, Monday through Friday, e-mail address [DTNA.Warranty.Campaigns@Daimlertruck.com](mailto:DTNA.Warranty.Campaigns@Daimlertruck.com). For other concerns, you may contact the Customer Assistance Center at (800) 385-4357. If your manufacturer, distributor, or dealer fails to remedy the defect or noncompliance without charge and within a reasonable time, you may wish to submit a complaint to the Administrator, National Highway Traffic Safety Administration, 1200 New Jersey Avenue SE, Washington, DC 20590; or call the Vehicle Safety Hotline at (888) 327-4236 (TTY: 800-424-9153); or go to <http://www.nhtsa.gov>.

We regret any inconvenience this action may cause but feel certain you understand our interest in motor vehicle safety.

WARRANTY CAMPAIGNS DEPARTMENT

Enclosure

December 2023  
FL979A-F  
NHTSA #23V-467  
Transport Canada #2023-372  
REVISED (May 2024)

## **Reimbursement to Customers for Repairs Performed Prior to Recall**

If you have already **paid** to have this recall condition corrected you may be eligible to receive reimbursement.

Requests for reimbursement may include parts and labor. Reimbursement may be limited to the amount the repair would have cost if completed by an authorized Daimler Truck North America LLC dealer. The following documentation must be presented to your dealer for consideration for reimbursement.

Please provide original or clear copies of all receipts, invoices, and repair orders that show:

- The name and address of the person who paid for the repair
- The Vehicle Identification Number (VIN) of the vehicle that was repaired
- What problem occurred, what repair was done, when the repair was done
- Who repaired the vehicle
- The total cost of the repair expense that is being claimed
- Proof of payment for the repair (such as the front and back of a cancelled check or a credit card receipt)

Reimbursement will be made by check from your Daimler Truck North America LLC dealer.

Please speak with your Daimler Truck North America LLC authorized dealer concerning this matter.

December 2023  
FL979A-F  
NHTSA #23V-467  
Transport Canada #2023-372  
REVISED (May 2024)

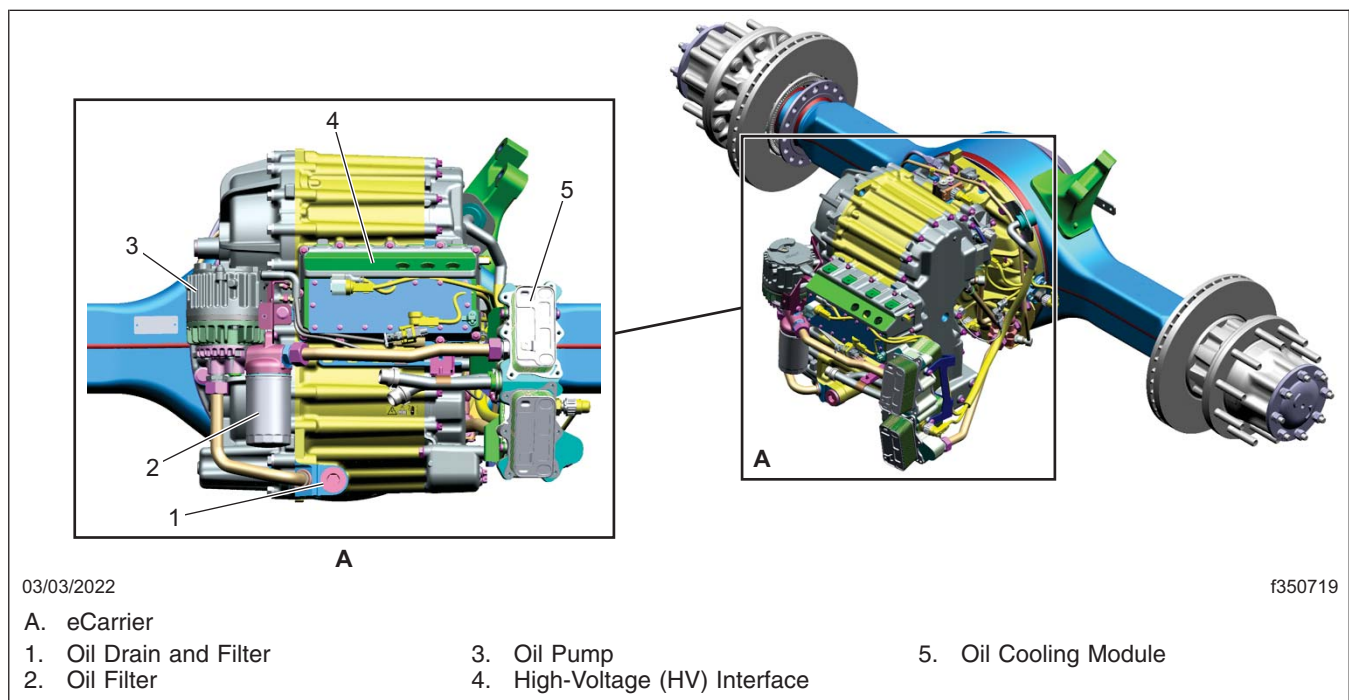
## Work Instructions

### Subject: Freightliner eCascadia e-Axle Ring Gear

Models Affected: Specific model years 2023-2024 Freightliner eCascadia vehicles manufactured between January 19, 2023, through April 13, 2023.

### FL979A-D – Front or Single e-Axle

The eCarrier components are shown in [Fig. 1](#).

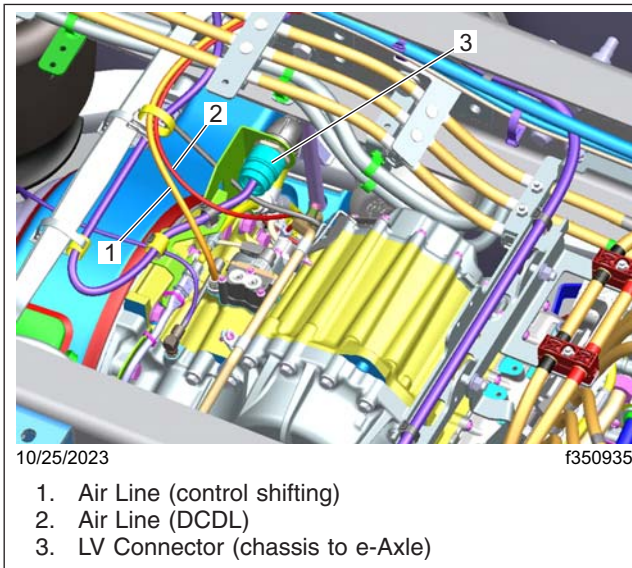


**Fig. 1, eCarrier Components**

1. Check the base label (Form WAR259) for a completion sticker for FL979 (Form WAR260) indicating this work has been done. The base label is usually located on the passenger-side door, about 12 inches (30 cm) below the door latch. If a recall completion sticker is present, no work is needed. If there is no sticker, proceed with the next step.
2. Park the vehicle on a level surface. Turn the keyswitch to the OFF position, place the vehicle in neutral, and set the park brake. Chock the tires.
3. Drain the air from the vehicle's air system.
4. Decommission the vehicle and verify the HV system is shut down. For instructions, see **Section 08.08** of the *eCascadia Workshop Manual*.
5. Remove the drive wheel fairings. For instructions, see **Section 31.04** of the *eCascadia Workshop Manual*.
6. Take the mobile wheel lift column and position it at each corner of the vehicle.

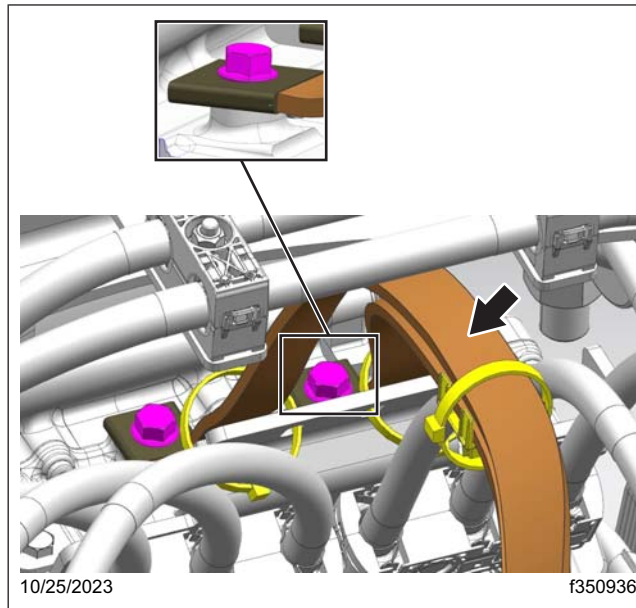
December 2023  
FL979A-F  
NHTSA #23V-467  
Transport Canada #2023-372  
REVISED (May 2024)

- Lift the vehicle. Remove all the tires on the axle being replaced, then lower the vehicle to the ground. For instructions to raise and lower the vehicle, see **Section 00.05** of the *eCascadia Workshop Manual*.
- Disconnect the low-voltage (LV) chassis harness from the e-Axle. See **Fig. 2**.



**Fig. 2, Location of the LV Connector**

- Disconnect the flat grounding cables straps, shown in **Fig. 3**, from the e-Axle.

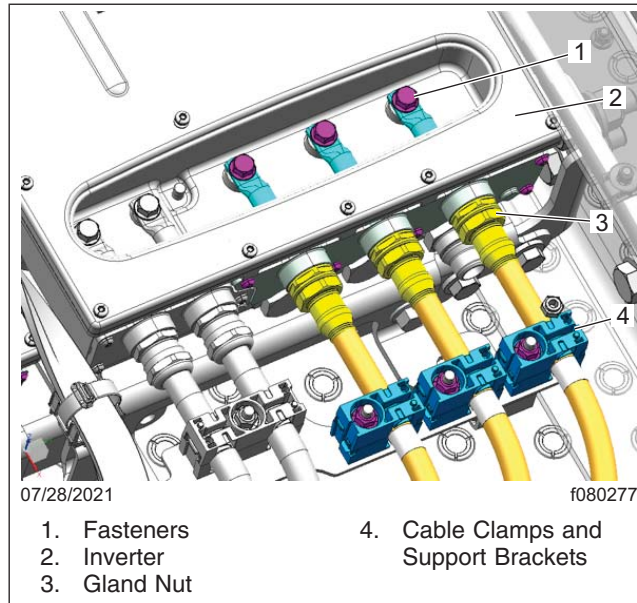


**Fig. 3, Flat Grounding Cables Straps**

- Remove the two rear deck plates that protect the inverters by removing the fasteners on each plate.

December 2023  
FL979A-F  
NHTSA #23V-467  
Transport Canada #2023-372  
REVISED (May 2024)

11. Remove the HV cable clamps and the mounting fasteners from the HV cable support brackets. Then, remove the support brackets. See [Fig. 4](#).

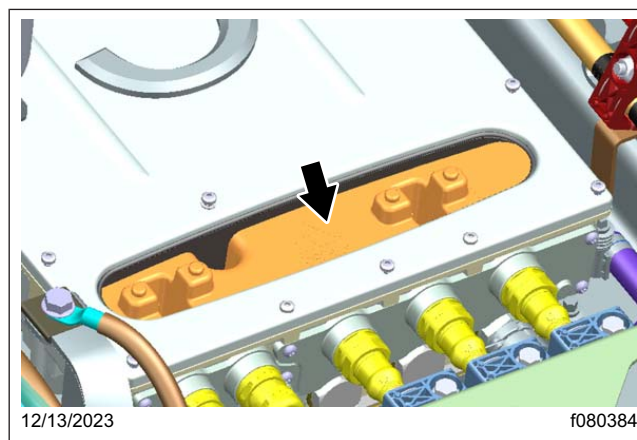


**Fig. 4, Inverter Side HV Cables**

**IMPORTANT:** Clean any dirt or debris from HV connectors before removing them. Failure to do so could increase the chance of dirt getting into the connector during installation.

12. Remove the inverter access cover.

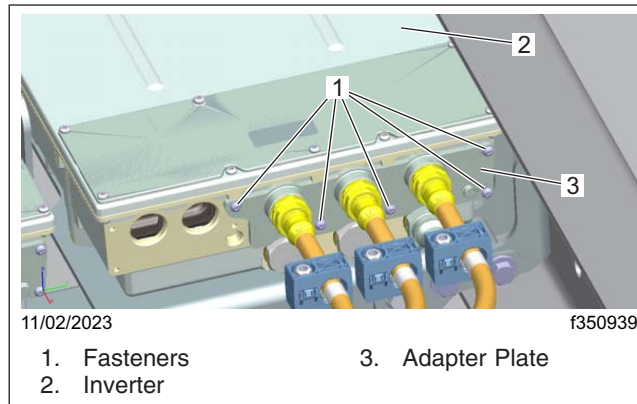
13. Remove the delayed access cover, shown in [Fig. 5](#).



**Fig. 5, Delayed Access Cover**

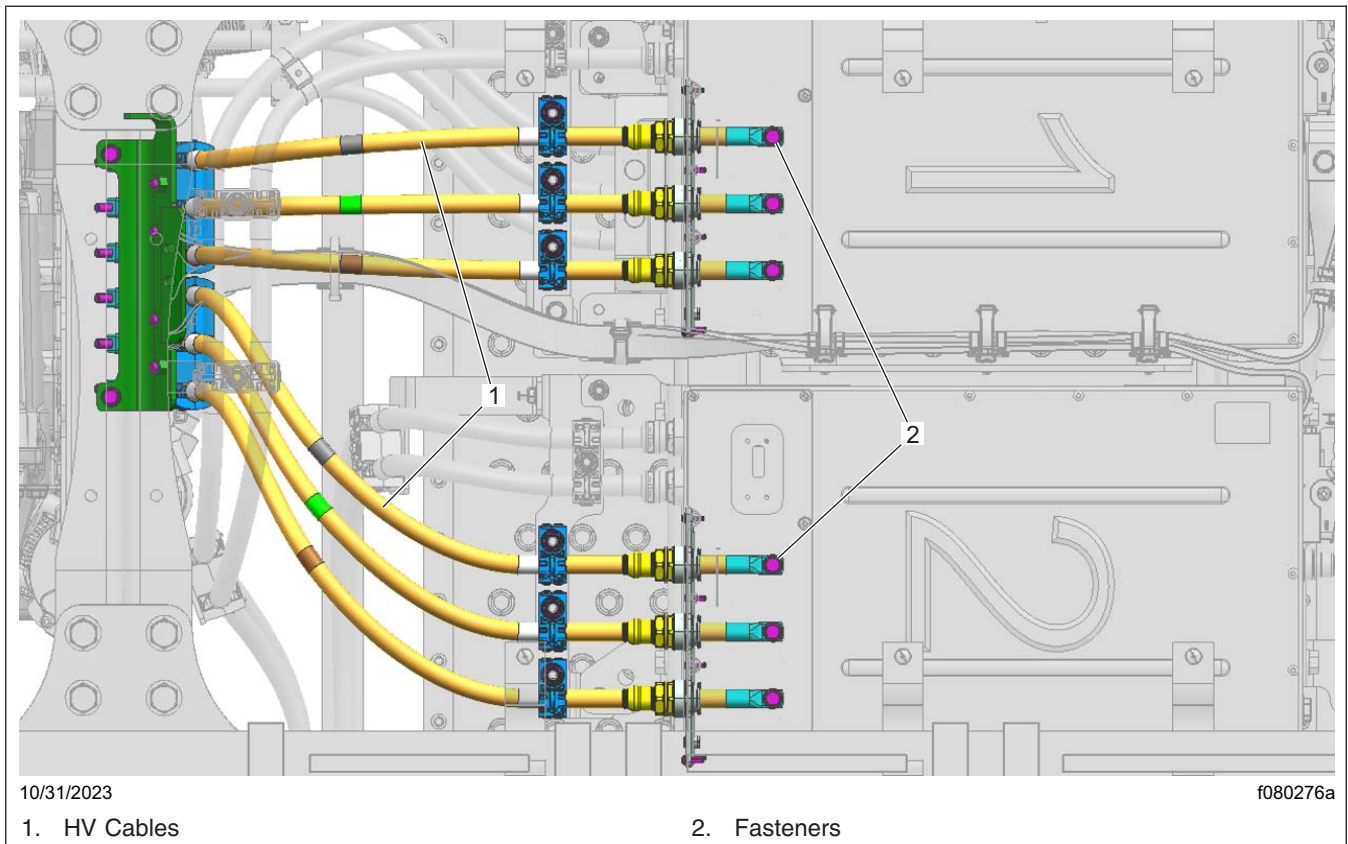
December 2023  
FL979A-F  
NHTSA #23V-467  
Transport Canada #2023-372  
REVISED (May 2024)

14. Remove the fasteners that secure the HV cables from the e-Axle to the rear side of the inverter. See [Fig. 4](#) and [Fig. 6](#).



**Fig. 6, Fasteners on the Rear Side of the Inverter**

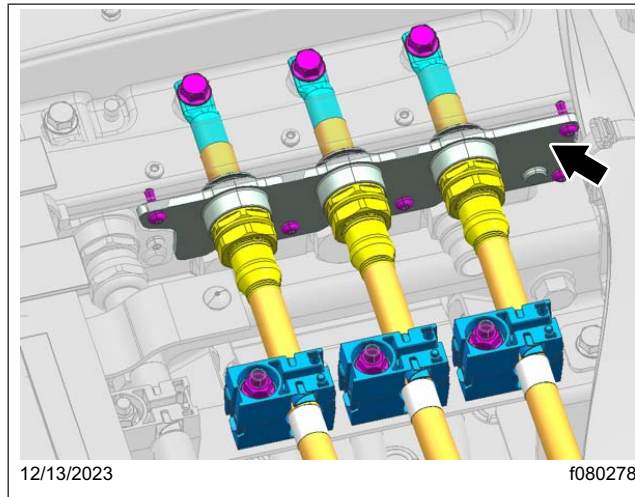
15. Remove the HV cable lug fasteners located inside the inverters 1 and 2. See [Fig. 7](#).



**Fig. 7, HV Cables Connecting the Inverter and the Forward Rear Axle**

December 2023  
FL979A-F  
NHTSA #23V-467  
Transport Canada #2023-372  
REVISED (May 2024)

16. Pull the cables out from the rear of the inverters. See **Fig. 8**.



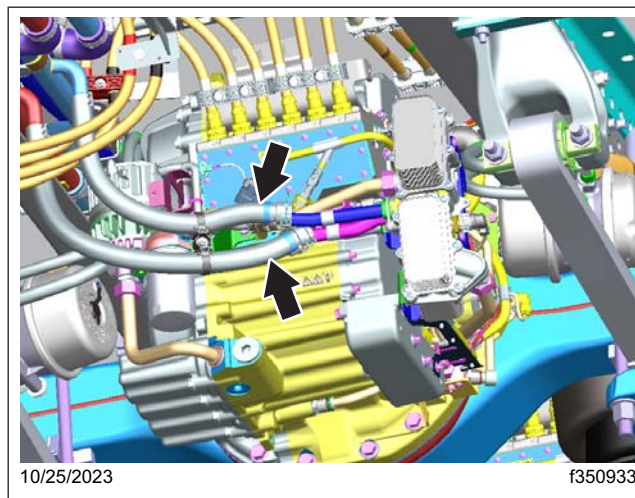
**Fig. 8, Location of the Adapter Plate**

17. Disconnect the air lines, shown in **Fig. 2** (page 8), from the eCarrier.

18. Lift the vehicle to the desired working height.

19. Cut the zip ties on the coolant hoses.

20. Disconnect the coolant lines, shown in **Fig. 9**, from the e-Axle, and let the fluid drain out.



**Fig. 9, Location of the Coolant Lines**

21. Place the e-Axle cart under the vehicle and rest the e-Axle on it.

22. Remove the fasteners that hold the control rod to the e-Axle tower.

23. Remove the upper shock bolts.

24. Remove the fasteners that secure the lower air bag.

25. Cage the rear brake chambers on both sides of the e-Axle. For instructions, see **Section 42.14, Subject 110** of the *eCascadia Workshop Manual*.

December 2023

FL979A-F

NHTSA #23V-467

Transport Canada #2023-372

REVISED (May 2024)

26. Remove the antilock braking system (ABS) sensor wiring from the mounting locations on driver-side of the vehicle.
  27. Remove the ABS sensor from the spider plate on the driver-side of the vehicle.
  28. Disconnect all the brake chamber air lines at the caliper side on both sides of the e-Axle.
  29. Remove the ABS sensor wiring from the mounting locations on the passenger-side of the vehicle.
  30. Remove the ABS sensor from the spider plate, on the passenger-side of the vehicle.
  31. Remove the front suspension fasteners.
  32. Raise the vehicle off the e-Axle.
  33. Remove the spider plate. For instructions, see **Group 42** of the *eCascadia Workshop Manual*.
  34. Remove the four U-bolt nuts, then remove the U-bolts and the clamp group from the both sides of the e-Axle.
  35. Remove the old e-Axle from the cart and place the new e-Axle on the cart for buildup and installation.
  36. Paint the new e-Axle.
  37. Install the spider plate. For instructions, see **Group 42** of the *eCascadia Workshop Manual*.
  38. Install the airliner suspension springs on the new e-Axle housing. Then, install the U-bolts and the clamp group on the both sides of the e-Axle.
  39. Raise the vehicle, and lower it close to the new e-Axle.
  40. Install the front suspension fasteners.
  41. Install the fasteners that secure the lower air bag.
  42. Install the fasteners that hold the control rod to the e-Axle tower.
  43. Install the upper shock bolts.
  44. Tighten the front suspension fasteners 190 to 210 lbf·ft (258 to 285 N·m).
  45. Tighten the upper shock bolts 162 lbf·ft (220 N·m).
  46. Tighten the control rod fasteners 136 lbf·ft (184 N·m).
  47. Tighten the air bag fasteners 55 lbf·ft (75 N·m).
  48. Tighten the U-bolt nuts in two stages. Start with 200 lbf·ft (271 N·m), and then finish by tightening them to 400 lbf·ft (542 N·m).
  49. Install all the air brake chamber lines at the caliper side.
  50. Install both the ABS sensors.
  51. Connect the air lines, shown in **Fig. 2** (page 8), to the eCarrier.
  52. Connect the LV chassis harness, shown in **Fig. 2** (page 8), to the e-Axle.
- NOTE: Use McMaster-Carr's Chemical-Resistant Seal and O-Ring Grease or equivalent on the O-rings.
53. Grease the O-rings that are located on the adapter plate of the new cables.
  54. Install the HV cables to the inverter.
  55. Install the lug fasteners inside the inverters.
  56. Install the fasteners that secure the adapter plate on the inverter.
  57. Tighten the adapter plate fasteners 48 lbf·in (542 N·cm). For instructions on the tightening sequence, see **Section 08.02, Subject 050** of the *eCascadia Workshop Manual*.
  58. Tighten the lug fasteners 17 lbf·ft (23 N·m).
  59. Install the HV cable support bracket and the HV cable clamps. Tighten the fasteners 11 lbf·ft (15 N·m).
  60. Connect the flat ground cable straps, shown in **Fig. 3** (page 8), to the e-Axle.

December 2023  
FL979A-F  
NHTSA #23V-467  
Transport Canada #2023-372  
REVISED (May 2024)

61. Install the zip ties on the flat ground cable straps.
62. Tighten the flat ground cable straps 18 lbf-ft (24 N·m).
63. Install the height control rod.
64. Install the wheel and tire. For instructions, see **Group 40** of the *eCascadia Workshop Manual*.
65. Remove the e-Axle cart.
66. Connect the coolant lines, shown in **Fig. 9** (page 11), to the e-Axle.
67. Install the drive wheel fairings. For instructions, see **Section 31.04** of the *eCascadia Workshop Manual*.
68. Fill the eCarrier and housing with fluid until the oil level reaches the fill plug threads. For instructions, see **Section 35.03** of the *eCascadia Maintenance Manual*.
69. Commission the vehicle (Gen 2). For instructions, see **Section 08.08, Subject 100** of the *eCascadia Workshop Manual*.
70. Install the delayed access cover, shown in **Fig. 5** (page 9).

NOTE: Use McMaster-Carr's Chemical-Resistant Seal and O-Ring Grease or equivalent on the O-rings.

71. Install the inverter access cover and tighten all the fasteners 44 lbf-in (497 N·cm) in the sequence shown in **Fig. 10**. For detailed instructions, see **Section 08.02, Subject 050** of the *eCascadia Workshop Manual*.

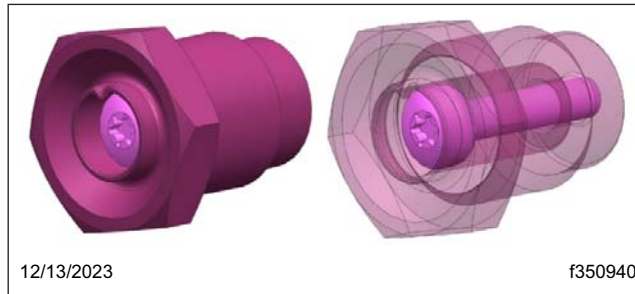


**Fig. 10, Inverter Access Cover Tightening Sequence**

72. Install the two rear deck plates and tighten the fasteners 11 to 15 lbf-ft (15 to 20 N·m).
73. Run DiagnosticLink® for the resolver re-learn function on the inverters 1 and 2.
74. Use a long T30 Torx® driver to loosen the center bolt of the neutral tool from the shift location.
75. Use a 30-mm socket to remove the neutral tool from the shift location. See **Fig. 11**.

December 2023  
FL979A-F  
NHTSA #23V-467  
Transport Canada #2023-372  
REVISED (May 2024)

75. Use a 30-mm socket to remove the neutral tool from the shift location. See [Fig. 11](#).

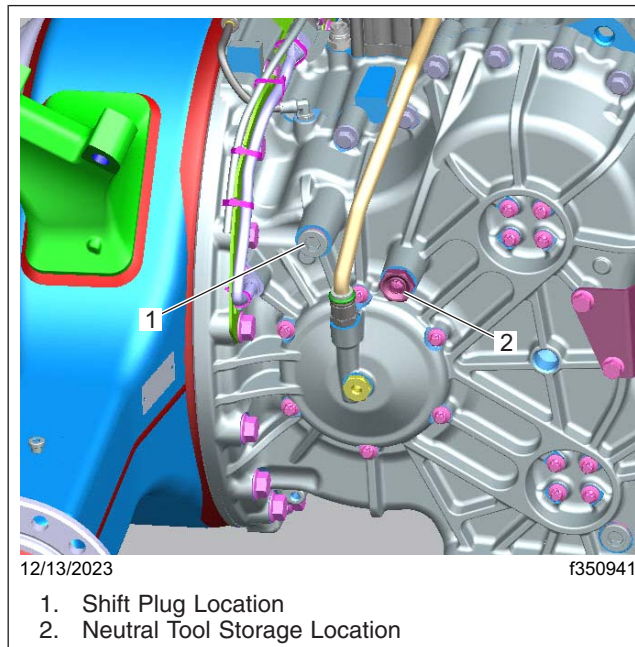


**Fig. 11, Neutral Tool**

76. Use a 14-mm hex bit to remove the shift plug from the storage location. Discard the crush washer.

NOTE: Apply a small amount of Loctite® 567 to the threads.

77. Install the new crush washer on the shift plug, and install the plug in the shift location. Tighten the tool 76 to 94 lbf·ft (103 to 127 N·m). See [Fig. 12](#).



**Fig. 12, Shift Plug and Neutral Tool**

78. Install the neutral tool in the storage location, and tighten 76 to 94 lbf·ft (103 to 127 N·m).

79. Tighten the center bolt of the neutral tool 80 to 98 lbf·in (904 to 1107 N·cm).

80. Fill and bleed the vehicle cooling system for circuit 1. For instructions, see **Section 20.01, Subject 160** of the *eCascadia Workshop Manual*.

81. Return the seal remover and the seal driver.

82. Complete the vehicle alignment and the calibration of the steering angle sensor.

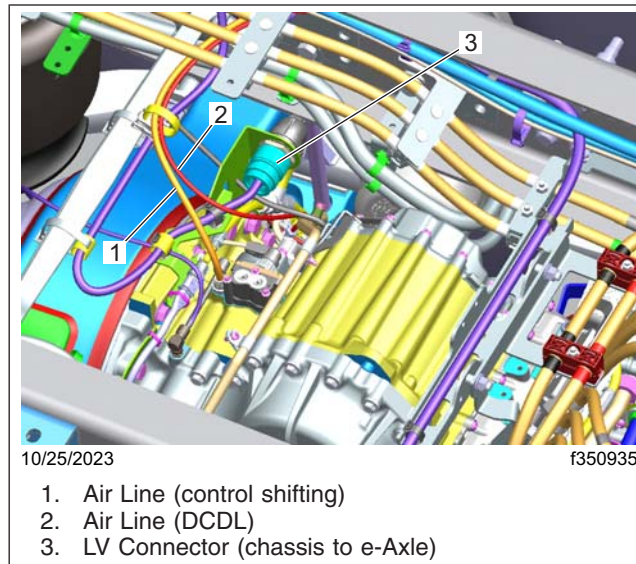
83. Test drive the vehicle.

84. Clean a spot on the base label (Form WAR259), and attach a recall completion sticker for FL979 (Form WAR260), indicating this work has been completed.

December 2023  
FL979A-F  
NHTSA #23V-467  
Transport Canada #2023-372  
REVISED (May 2024)

## FL979E-F – Rear e-Axle in a Tandem Set

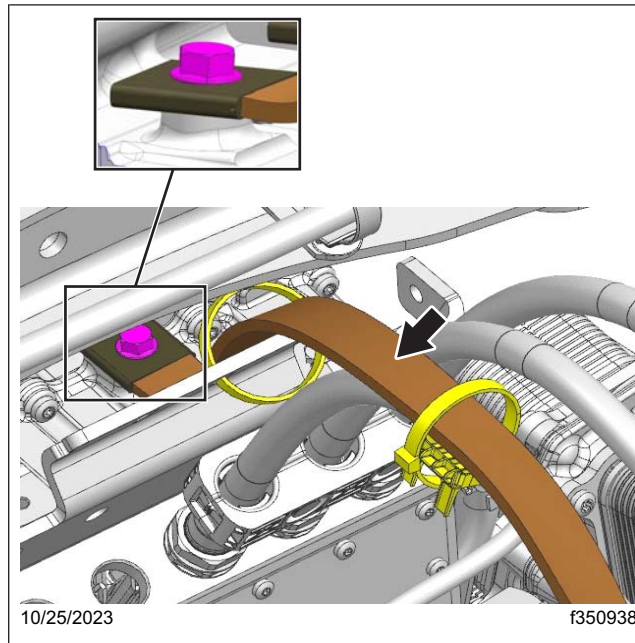
1. Check the base label (Form WAR259) for a completion sticker for FL979 (Form WAR260) indicating this work has been done. The base label is usually located on the passenger-side door, about 12 inches (30 cm) below the door latch. If a recall completion sticker is present, no work is needed. If there is no sticker, proceed with the next step.
2. Park the vehicle on a level surface. Turn the keyswitch to the OFF position, place the vehicle in neutral, and set the park brake. Chock the tires.
3. Drain the air from the vehicle's air system.
4. Decommission the vehicle and verify the high-voltage (HV) system is shut down. For instructions, see **Section 08.08** of the *eCascadia Workshop Manual*.
5. Remove the drive wheel fairings. For instructions, see **Section 31.04** of the *eCascadia Workshop Manual*.
6. Take the mobile wheel lift column and position it at each corner of the vehicle.
7. Lift the vehicle. Remove all the tires on the axle being replaced, then lower the vehicle to the ground. For instructions to raise and lower the vehicle, see **Section 00.05** of the *eCascadia Workshop Manual*.
8. Disconnect the low-voltage (LV) chassis harness from the e-Axle. See **Fig. 13**.



**Fig. 13, Location of the LV Connector**

December 2023  
FL979A-F  
NHTSA #23V-467  
Transport Canada #2023-372  
REVISED (May 2024)

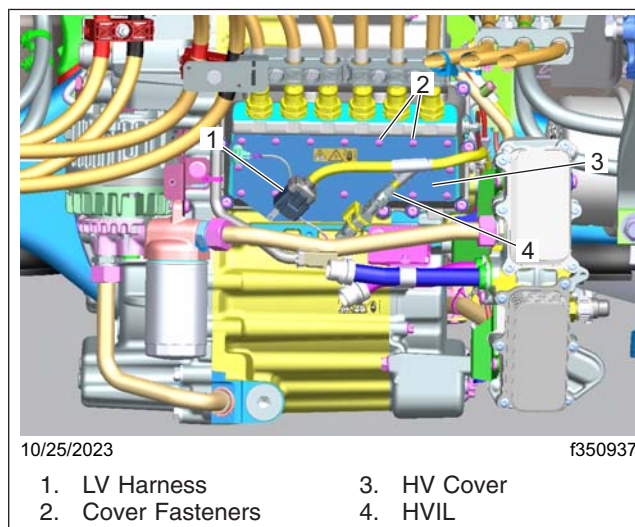
9. Disconnect the flat grounding cables straps, shown in [Fig. 14](#), from the e-Axle.



**Fig. 14, Flat Grounding Cables Straps**

10. Remove the fasteners from the HV cable clamps that are connected just above the e-Axle gland nuts.

11. Disconnect the high-voltage interlock (HVIL) and the LV harness from the HV cover. See [Fig. 15](#).



**Fig. 15, Location of the HVIL**

12. Remove the HV cover fasteners and remove the HV cover. See [Fig. 15](#).

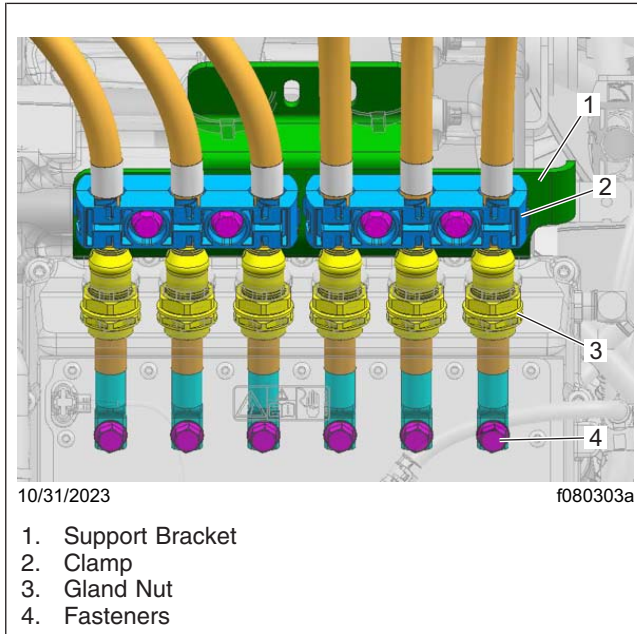
13. Remove and discard the HV cover gasket.

14. Remove the HV cable lug fasteners located inside the e-Axle HV interface.

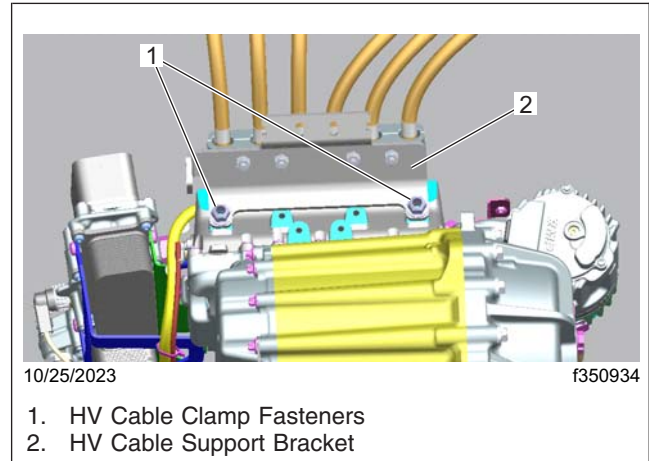
15. Remove the HV cable support bracket and the mounting fasteners that are mounted to the eCarrier. See [Fig. 16](#) and [Fig. 17](#).

December 2023  
FL979A-F  
NHTSA #23V-467  
Transport Canada #2023-372  
REVISED (May 2024)

15. Remove the HV cable support bracket and the mounting fasteners that are mounted to the eCarrier. See [Fig. 16](#) and [Fig. 17](#).

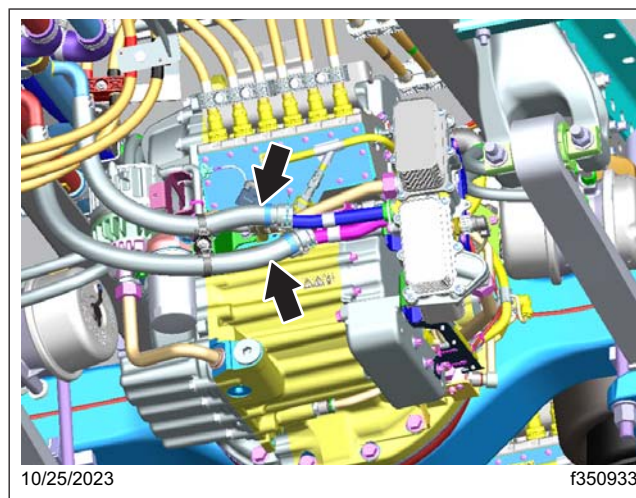


**Fig. 16, Axle Side HV Cable Removal**



**Fig. 17, HV Cable Support Bracket**

16. Disconnect the cable gland connections.
17. Remove the cables from the e-Axle.
18. Disconnect the air lines, shown in [Fig. 13](#) (page 15), from the eCarrier.
19. Lift the vehicle to the desired working height.
20. Cut the zip ties on the coolant hoses.
21. Disconnect the coolant lines from the e-Axle, and let the fluid drain out. See [Fig. 18](#).



**Fig. 18, Location of the Coolant Lines**

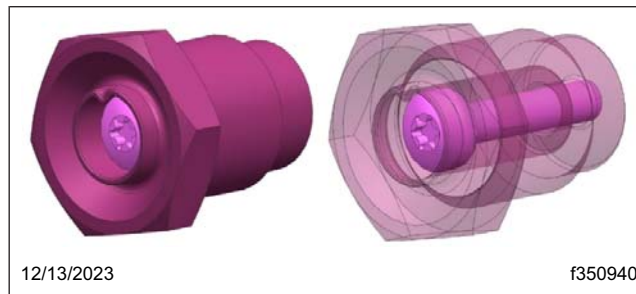
22. Place the e-Axle cart under the vehicle and rest the e-Axle on it.
23. Remove the fasteners that hold the control rod to the e-Axle tower.

December 2023  
FL979A-F  
NHTSA #23V-467  
Transport Canada #2023-372  
REVISED (May 2024)

24. Remove the upper shock bolts.
25. Remove the fasteners that secure the lower air bag.
26. Cage the rear brake chambers on both sides of the e-Axle. For instructions, see **Section 42.14, Subject 110** of the *eCascadia Workshop Manual*.
27. Remove the antilock braking system (ABS) sensor wiring from the mounting locations on driver-side of the vehicle.
28. Remove the ABS sensor from the spider plate on the driver-side of the vehicle.
29. Disconnect all the brake chamber air lines at the caliper side on both sides of the e-Axle.
30. Remove the ABS sensor wiring from the mounting locations on the passenger-side of the vehicle.
31. Remove the ABS sensor from the spider plate, on the passenger-side of the vehicle.
32. Remove the front suspension fasteners.
33. Raise the vehicle off the e-Axle.
34. Remove the spider plate. For instructions, see **Group 42** of the *eCascadia Workshop Manual*.
35. Remove the four U-bolt nuts, then remove the U-bolts and the clamp group from the both sides of the e-Axle.
36. Remove the old e-Axle from the cart and place the new e-Axle on the cart for buildup and installation.
37. Paint the new e-Axle.
38. Install the spider plate. For instructions, see **Group 42** of the *eCascadia Workshop Manual*.
39. Install the airliner suspension springs on the new e-Axle housing. Then, install the U-bolts and the clamp group on the both sides of the e-Axle.
40. Raise the vehicle, and lower it close to the new e-Axle.
41. Install the front suspension fasteners.
42. Install the fasteners that secure the lower air bag.
43. Install the fasteners that hold the control rod to the e-Axle tower.
44. Install the upper shock bolts.
45. Tighten the front suspension fasteners 190 to 210 lbf-ft (258 to 285 N·m).
46. Tighten the upper shock bolts 162 lbf-ft (220 N·m).
47. Tighten the control rod fasteners 136 lbf-ft (184 N·m).
48. Tighten the air bag fasteners 55 lbf-ft (75 N·m).
49. Tighten the U-bolt nuts in two stages. Start with 200 lbf-ft (271 N·m), and then finish by tightening them to 400 lbf-ft (542 N·m).
50. Install all the air brake chamber lines at the caliper side.
51. Install both the ABS sensors.
52. Connect the air lines, shown in **Fig. 13** (page 15), to the eCarrier.
53. Connect the LV chassis harness, shown in **Fig. 13** (page 15), to the e-Axle.
54. Install the HV cables to the eAxle HV interface.
55. Connect the cable glands to the eCarrier.
56. Install the HV cable lug fasteners inside the eAxle HV interface.
57. Install and tighten the cable gland connections 9 lbf-ft (12 N·m).

December 2023  
FL979A-F  
NHTSA #23V-467  
Transport Canada #2023-372  
REVISED (May 2024)

58. Tighten the lug fasteners 17 lbf·ft (23 N·m).
59. Clean the gasket material from the HV header, then position a new gasket on the HV header.
60. Install the HV cover and fasteners to the HV interface on the e-Axle. See **Fig. 15** (page 16).
61. Tighten the HV cover fasteners 4 lbf·ft (5 N·m).
62. Connect the LV to the e-Axle HV cover.
63. Install the support bracket on top of the eCarrier. Then, install the HV cable clamps. See **Fig. 16** (page 17).
64. Connect the flat ground cable straps, shown in **Fig. 14** (page 16), to the e-Axle.
65. Install the zip ties on the flat ground cable straps.
66. Tighten the flat ground cable straps 18 lbf·ft (24 N·m).
67. Install the height control rod.
68. Install the wheel and tire. For instructions, see **Group 40** of the *eCascadia Workshop Manual*.
69. Remove the e-Axle cart.
70. Connect the coolant lines, shown in **Fig. 18** (page 17), to the e-Axle.
71. Install the drive wheel fairings. For instructions, see **Section 31.04** of the *eCascadia Workshop Manual*.
72. Fill the eCarrier and housing with fluid until the oil level reaches the fill plug threads. For instructions, see **Section 35.03** of the *eCascadia Maintenance Manual*.
73. Commission the vehicle (Gen 2). For instructions, see **Section 08.08, Subject 100** of the *eCascadia Workshop Manual*.
74. Run DiagnosticLink® for the resolver re-learn function on the inverter 3.
75. Use a long T30 Torx® driver to loosen the center bolt of the neutral tool from the shift location.
76. Use a 30-mm socket to remove the neutral tool from the shift location. See **Fig. 19**.



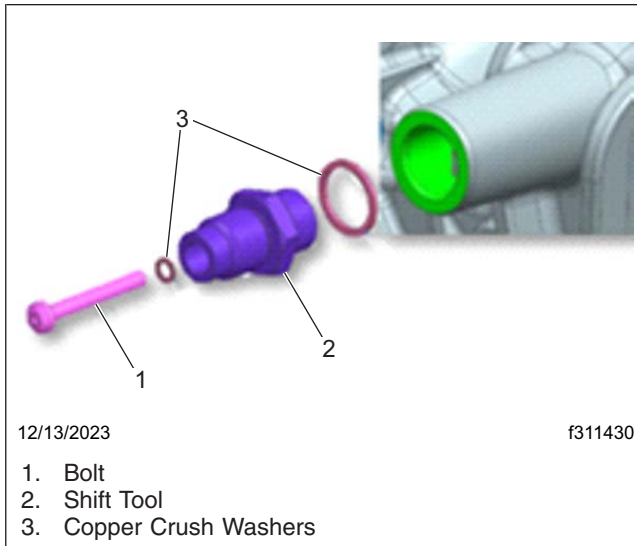
**Fig. 19, Neutral Tool**

77. Use a long T30 Torx driver to remove the center bolt from the second gear tool from the storage location. Remove and discard the copper crush washer.
78. Use a 30-mm socket to remove the shift tool from the storage location. Discard the crush washer.

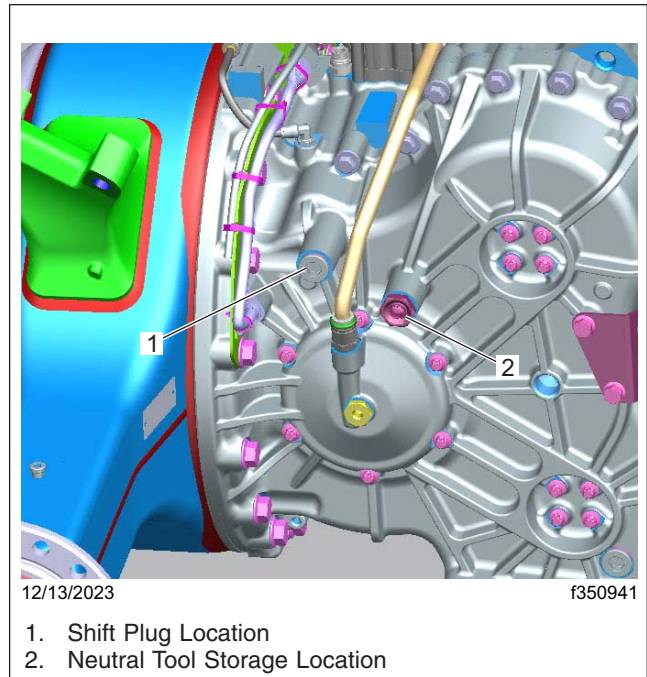
December 2023  
FL979A-F  
NHTSA #23V-467  
Transport Canada #2023-372  
REVISED (May 2024)

NOTE: Apply a small amount of Loctite® 567 to the threads.

79. Install the new crush washer on the second gear tool, and install the tool in the shift location. Tighten the tool 76 to 94 lbf-ft (103 to 127 N·m). See [Fig. 20](#) and [Fig. 21](#).



**Fig. 20, Gear Shift Tool**



**Fig. 21, Shift Plug and Neutral Tool**

80. Make sure the new crush washer is correctly positioned, then install the center bolt. Tighten the center bolt 80 to 98 lbf-in (904 to 1107 N·cm).
81. Fill and bleed the vehicle cooling system for circuit 1. For instructions, see **Section 20.01, Subject 160** of the *eCascadia Workshop Manual*.
82. Return the seal remover and the seal driver.
83. Complete the vehicle alignment and the calibration of the steering angle sensor.
84. Test drive the vehicle.
85. Clean a spot on the base label (Form WAR259), and attach a recall completion sticker for FL979 (Form WAR260), indicating this work has been completed.