



Stacy L. Balzer  
 Operating Director  
 Service Engineering Operations  
 Ford Customer Service Division

Ford Motor Company  
 P. O. Box 1904  
 Dearborn, Michigan 48121

March 15, 2023

**TO:** All U.S. Ford and Lincoln Dealers

**SUBJECT:** **NEW VEHICLE DEMONSTRATION / DELIVERY HOLD**  
**\*DO NOT DRIVE VEHICLES\***  
**Safety Recall 23S09**  
 Certain 2022-2023 Model Year Bronco – Wildtrak & Raptor Models  
 Steering Gear Replacement

**REF:** **NEW VEHICLE DEMONSTRATION / DELIVERY HOLD - Advance Notice -**  
**Safety Recall 23S09**  
 Dated: March 3, 2023

**AFFECTED VEHICLES**

| Vehicle                       | Model Year | Assembly Plant | Build Dates                     |
|-------------------------------|------------|----------------|---------------------------------|
| Bronco<br>(Wildtrak & Raptor) | 2022       | Michigan       | 30-Aug-2022 through 26-Oct-2022 |
|                               | 2023       |                | 21-Nov-2022 through 01-Mar-2023 |

Affected vehicles are identified in OASIS and Attachment IV VIN Lists. VINs will also be loaded to the FSA VIN lists. This program involves 155 delivered U.S. vehicles. Service parts are not affected.

**THE VEHICLES IN THIS PROGRAM ARE NOT TO BE DRIVEN UNTIL THIS REPAIR HAS BEEN PERFORMED**

When operating affected vehicles, it is possible that the steering may lock causing a complete loss of steering control. This may increase the risk of a crash.

**REASON FOR THIS SAFETY RECALL**

In some of the affected vehicles, an internal component of the steering gear may have been damaged during steering gear manufacturing. This damage to the steering gear may result in increased steering efforts and the potential to not be able to turn the steering wheel while driving, increasing the risk of a crash.

**SERVICE ACTION**

Before **DRIVING**, DEMONSTRATING, OR DELIVERING any new in-stock vehicles involved in this safety recall, dealers are to replace the steering gear. This service must be performed on all affected vehicles at no charge to the vehicle owner.

Owners are advised not to drive the affected vehicles (see VIN list) until this repair has been completed. To assist vehicle owners having this repair completed dealers should:

- Proactively contact owners to instruct them to stop driving their vehicle
- Arrange to tow the owner’s vehicle to the dealership for repairs (rentals are authorized – see Rental Vehicles)
- Re-delivery of the owner’s vehicle after repairs have been completed

## **OWNER NOTIFICATION MAILING SCHEDULE**

Owner letters are expected to be mailed the week of March 27, 2023. Dealers should repair any affected vehicles that arrive at their dealerships, whether or not the customer has received a letter.

### **PLEASE NOTE:**

**Federal law requires dealers to complete this recall service before a new vehicle is delivered to the buyer or lessee. Violation of this requirement by a dealer could result in a civil penalty of up to \$26,315 per vehicle. Correct all vehicles in your new vehicle inventory before delivery.**

### **ATTACHMENTS**

Attachment I: Administrative Information  
Attachment II: Labor Allowances and Parts Ordering Information  
Attachment III: Technical Information  
Attachment IV: Affected Vehicle VIN List  
Owner Notification Letters  
Recall Reimbursement Plan

### **QUESTIONS & ASSISTANCE**

For questions and assistance, contact the Special Service Support Center (SSSC) via the SSSC Web Contact Site. The SSSC Web Contact Site can be accessed through the Professional Technician System (PTS) website using the SSSC link listed at the bottom of the OASIS VIN report screen or listed under the SSSC tab.

Sincerely,



Stacy L. Balzer

**NEW VEHICLE DEMONSTRATION / DELIVERY HOLD – DO NOT DRIVE VEHICLES**

**Safety Recall 23S09**

Certain 2022-2023 Model Year Bronco – Wildtrak & Raptor Models  
Steering Gear Replacement

**OASIS ACTIVATION**

OASIS was activated on March 3, 2023.

**FSA VIN LISTS ACTIVATION**

FSA VIN Lists were available through <https://web.fsavinlists.dealerconnection.com> on March 3, 2023. Owner names and addresses will be available by April 7, 2023.

**NOTE:** Your FSA VIN Lists may contain owner names and addresses obtained from motor vehicle registration records. The use of such motor vehicle registration data for any purpose other than in connection with this recall is a violation of law in several states, provinces, and countries. Accordingly, you must limit the use of this listing to the follow-up necessary to complete this recall.

**SOLD VEHICLES**

- Ford has issued instructions to stop selling/delivering or driving used vehicles under this safety recall. Owners should contact their dealer for an appointment to have their vehicles remedied as soon as practicable.
- Immediately contact any of your affected customers whose vehicles are not on your VIN list but are identified in OASIS. Give the customer a copy of the Owner Notification Letter (when available) and schedule a service date.
- Correct other affected vehicles identified in OASIS which are brought to your dealership.
- Dealers are to prioritize repairs of customer vehicles over repairs of new and used vehicle inventory.

**STOCK VEHICLES**

- Correct all affected units in your new vehicle inventory before delivery.
- Use OASIS to identify any affected vehicles in your used vehicle inventory.

**DEALER-OPERATED RENTAL VEHICLES**

The Fixing America's Surface Transportation (FAST) Act law effective June 2016 prohibits a rental company from selling, renting or leasing vehicles subject to a safety or compliance recall. Please consult your legal counsel for legal advice.

**TITLE BRANDED / SALVAGED VEHICLES**

Affected title branded and salvaged vehicles are eligible for this recall.

**NEW VEHICLE DEMONSTRATION / DELIVERY HOLD – DO NOT DRIVE VEHICLES****Safety Recall 23S09**

Certain 2022-2023 Model Year Bronco – Wildtrak & Raptor Models  
Steering Gear Replacement

**OWNER REFUNDS**

- **This safety recall must still be performed, even if the owner has paid for a previous repair. Claiming a refund will not close the recall on the vehicle.**
- Ford Motor Company is offering a refund for owner-paid repairs covered by this recall if the repair was performed before the date indicated in the reimbursement plan, which is posted with this bulletin. Owners are directed to seek reimbursement through authorized dealers or, at their option, directly through Ford Motor Company at P.O. Box 6251, Dearborn, MI 48121-6251.
- Dealers are also pre-approved to refund owner-paid emergency repairs that were performed away from an authorized servicing dealer after the end date specified in the reimbursement plan. Non-covered repairs, or those judged by Ford to be excessive, will not be reimbursed.
- Refunds will only be provided for the cost associated with the replacement of the steering gear.

**RENTAL VEHICLES**

Dealers are pre-approved for up to 20 days for a rental vehicle if service parts are unavailable. Dealers are pre-approved for 2 days of rental if service parts are available. Follow Extended Service Plan (ESP) guidelines for dollar amounts. Rentals will only be reimbursed for the day(s) the vehicle is at the dealership for part replacement. Prior approval for more than 20 rental days is required from the SSSC. Contact the SSSC via the SSSC Web Contact Site for consideration and approval if appropriate.

**TOWING**

Dealers are authorized to claim up to a maximum value of \$250 to provide towing services for this program.

**VEHICLE DELIVERY**

All customers affected by this program have the option of complimentary Vehicle Delivery service (at participating dealers). Refer to EFC12071, 2023 Remote Experience Program, Pickup & Delivery (PDL) Offset section for additional details.

**ADDITIONAL REPAIR (LABOR TIME AND/OR PARTS)**

Additional repairs identified as necessary to complete the FSA should be managed as follows:

- For related damage and access time requirements, refer to the Warranty and Policy Manual / Section 6 – Ford & Lincoln Program Policies / General Information & Special Circumstances for FSA's / Related Damage.
- For vehicles within new vehicle bumper-to-bumper warranty coverage, no SSSC approval is required, although related damage must be on a separate repair line with the "Related Damage" radio button checked.
  - Ford vehicles – 3 years or 36,000 miles
- For vehicles outside new vehicle bumper-to-bumper warranty coverage, submit an Approval Request to the SSSC Web Contact Site prior to completing the repair.

**NEW VEHICLE DEMONSTRATION / DELIVERY HOLD – DO NOT DRIVE VEHICLES****Safety Recall 23S09**

Certain 2022-2023 Model Year Bronco – Wildtrak & Raptor Models  
Steering Gear Replacement

**CLAIMS PREPARATION AND SUBMISSION**

- **Claim Entry:** Enter claims using Dealer Management System (DMS) or One Warranty Solution (OWS) online.
  - When entering claims, select claim type 31: Field Service Action. The FSA number 23S09 is the sub code.
  - For additional claims preparation and submission information, refer to the Recall and Customer Satisfaction Program (CSP) Repairs in the OWS User Guide.
- **Related Damage/Additional labor and/or parts:** Must be claimed as Related Damage on a separate repair line from the FSA with same claim type and sub code as described in Claim Entry above.

**IMPORTANT:** Click the Related Damage Indicator radio button.
- **Rentals:** For rental vehicle claiming, follow Extended Service Plan (ESP) guidelines for dollar amounts. Enter the total amount of the rental expense under Miscellaneous Expense code RENTAL.
- **Refunds:** Submit refunds on a separate repair line.
  - Program Code: 23S09                      - Misc. Expense: ADMIN
  - Misc. Expense: REFUND                - Misc. Expense: 0.2 Hrs.
  - Multiple refunds should be submitted on one repair line and the invoice details for each repair should be detailed in the comments section of the claim.
- **Vehicle Delivery:** Refer to EFC12071, 2023 Remote Experience Program, Pickup & Delivery (PDL) Offset section for additional details.
- **Provision for Towing:** Dealers are authorized to claim up to a maximum value of \$250 to provide towing services for completing this program. Submit on the same line as the repair.
  - Program Code: 23S09
  - Misc. Expense: OTHER
  - Misc. Expense: Claim up to \$250.00

**NEW VEHICLE DEMONSTRATION / DELIVERY HOLD – DO NOT DRIVE VEHICLES****Safety Recall 23S09**

Certain 2022-2023 Model Year Bronco – Wildtrak & Raptor Models  
Steering Gear Replacement

**LABOR ALLOWANCES**

| Description   | Labor Operation | Labor Time |
|---|-----------------|------------|
| Replace the steering gear assembly  | 23S09B          | 5.1 Hours  |
| Check and correct front toe<br>(Vehicles Not Equipped with Lane Keep Assist)  | 23S09C          | 0.8 Hours  |
| Check and correct front toe<br>(ONLY Vehicles Equipped with Lane Keep Assist) | 23S09D          | 1.1 Hours  |

**PARTS REQUIREMENTS / ORDERING INFORMATION****Special Program Part Ordering:**

Due to limited part availability, place an order for the steering gear and steering gear mounting bolts by submitting a VIN-specific Part Order contact via the SSSC Web Contact Site. For in stock unsold vehicles, a copy of the signed sales agreement is required to be sent in with the part request.

Dealers are to prioritize repairs of customer vehicles over repairs of new and used vehicle inventory.

| Part Number  | Description  | Order Quantity | Claim Quantity |
|--------------|--|----------------|----------------|
| NB3Z-3504-*  | Steering Gear  | 1              | 1              |
| W720880-S439 | Steering Gear Mounting Bolt – 4 bolts per pack,<br>2 required per repair | 1              | 2              |

Dealers will be notified via a DOES II communication if circumstances warrant a change in part supply strategy and when open ordering resumes.

**NOTE:** For additional required parts such as gaskets, fasteners, seals, etc. refer to the Workshop Manual (WSM) procedures.

**DEALER PRICE**

For latest prices, refer to DOES II.

**PARTS RETENTION, RETURN, & SCRAPPING**

Follow the provisions of the Warranty and Policy Manual, Section 1 - WARRANTY PARTS RETENTION AND RETURN POLICIES. If a replaced part receives a scrap disposition, the part must be scrapped in accordance with all applicable local, state, and federal environmental protection and hazardous material regulations. Federal law prohibits selling motor vehicle parts or components that are under safety, compliance, or emissions recall.

**EXCESS STOCK RETURN**

Excess stock returned for credit must have been purchased from Ford Customer Service Division in accordance with Policy Procedure Bulletin 4000.

**NEW VEHICLE DEMONSTRATION / DELIVERY HOLD – DO NOT DRIVE VEHICLES****Safety Recall 23S09**

Certain 2022-2023 Model Year Bronco – Wildtrak & Raptor Models  
Steering Gear Replacement

**REPLACED FSA PARTS INSPECTION AND SIGN OFF**

Effective March 1<sup>st</sup> 2021 all parts replaced as part of an FSA repair with a repair order open date of March 1<sup>st</sup> 2021 or later must be inspected and signed off on the repair order by a member of your dealers fixed operations management team or an employee the task has been delegated to. If the task is to be delegated to a non-management employee, the employee needs to be someone other than the technician who completed the repair and needs to understand the importance of completing this task consistently and accurately.

- All parts replaced as part of an FSA repair should be returned to the parts department following the Warranty Parts Retention and Return Policies.
- Inspect the replaced parts to verify the FSA repair was completed.
- If the FSA repair is found to be complete, the designated employee signs the repair order line or parts return stamp area (electronic or hand signed) for the FSA repair indicating the parts were inspected and validated to have been replaced.
- After the parts have been inspected, they should be handled based on the guidance in the parts status report in the Online Warranty System (Hold, Return, CORE, Scrap, etc.).
- This process is subject to review during warranty audits for FSA repairs with a repair order open date of March 1<sup>st</sup> 2021 or later. Any eligible FSA claims requiring parts replacement, found not to have been inspected and signed off during a warranty audit will be subject to chargeback and consideration for enrollment into the Dealer Incomplete Recall Repair Process.

**Note:** Other approvals (electronic or handwritten) for add-on repair lines, dealer owned vehicle repairs, and repeat repairs do not qualify as FSA parts inspection approvals. The post repair FSA parts inspection process (electronic or handwritten) is independent from other warranty approval requirements. The approval by the designated employee implies that the FSA parts were found to be replaced and must be able to be clearly identified on the Repair Order. If multiple FSAs require approval on a single Repair Order, each applicable occurrence will require individual post repair approval by the designated employee.

## CERTAIN 2022-2023 MODEL YEAR BRONCO WILDTRAK AND RAPTOR VEHICLES — STEERING GEAR REPLACEMENT

### SERVICE PROCEDURE

1. Position the vehicle on a hoist.
2. Disconnect the Battery. Follow the Workshop Manual (WSM) procedures in Section 414-01.
3. Connect a scan tool, connect and upload the module configuration information from the Power Steering Control Module (PSCM). Refer to: Module Programming (418-01A Module Configuration, General Procedures).

**NOTICE:** Do not allow the steering column to rotate while the steering column shaft is disconnected or damage to the steering column internal sensor may result.

4. Using a holding device, hold the steering wheel in the straight-ahead position. See Figure 1.

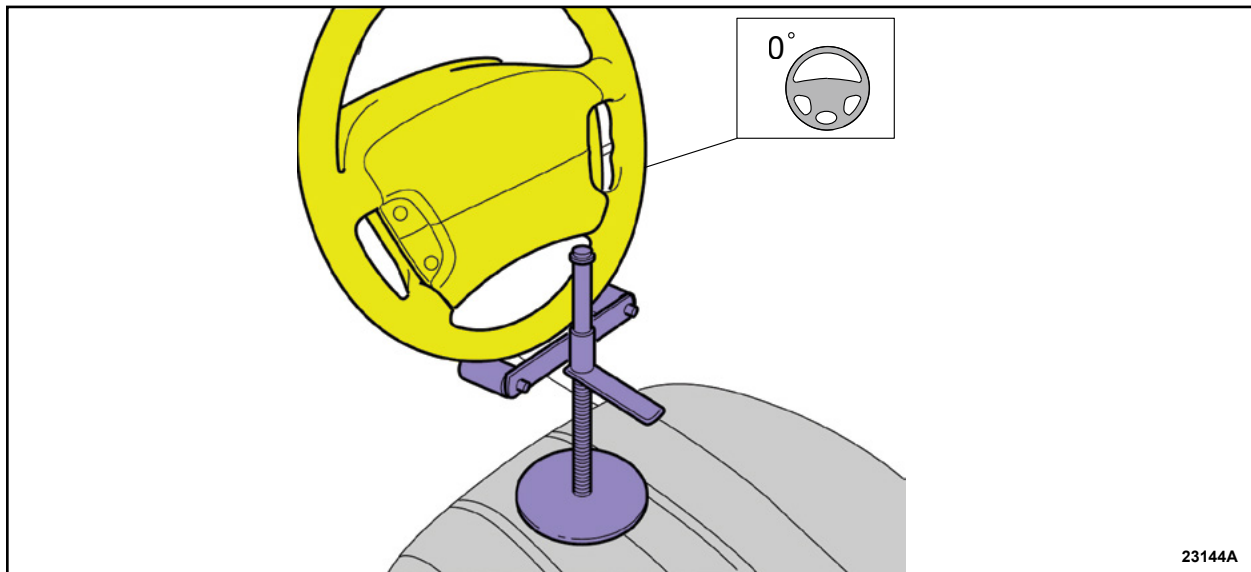

**FIGURE 1**

5. Remove the engine rear undershield. Follow the WSM procedures in Section 501-02.





6. If equipped, remove and discard the bolts and remove the stabilizer bar undershield. See Figure 2.

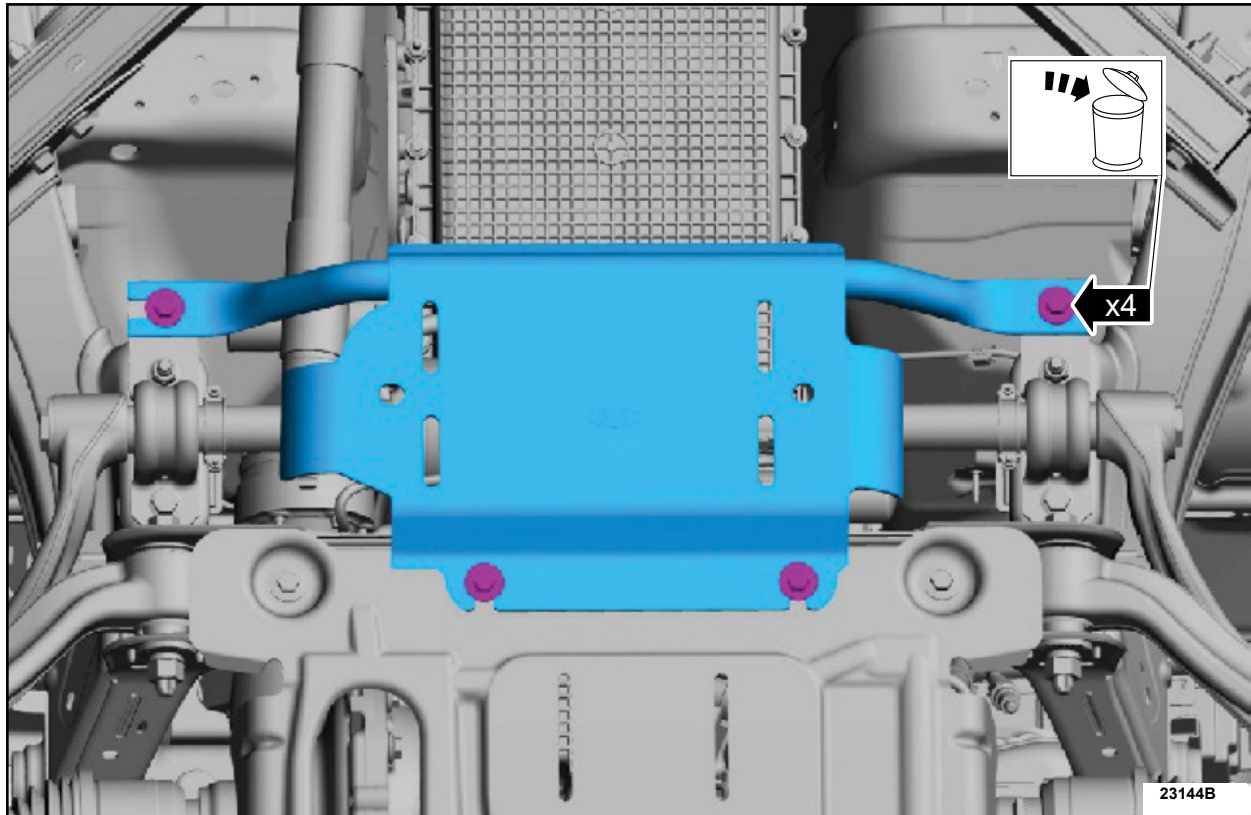
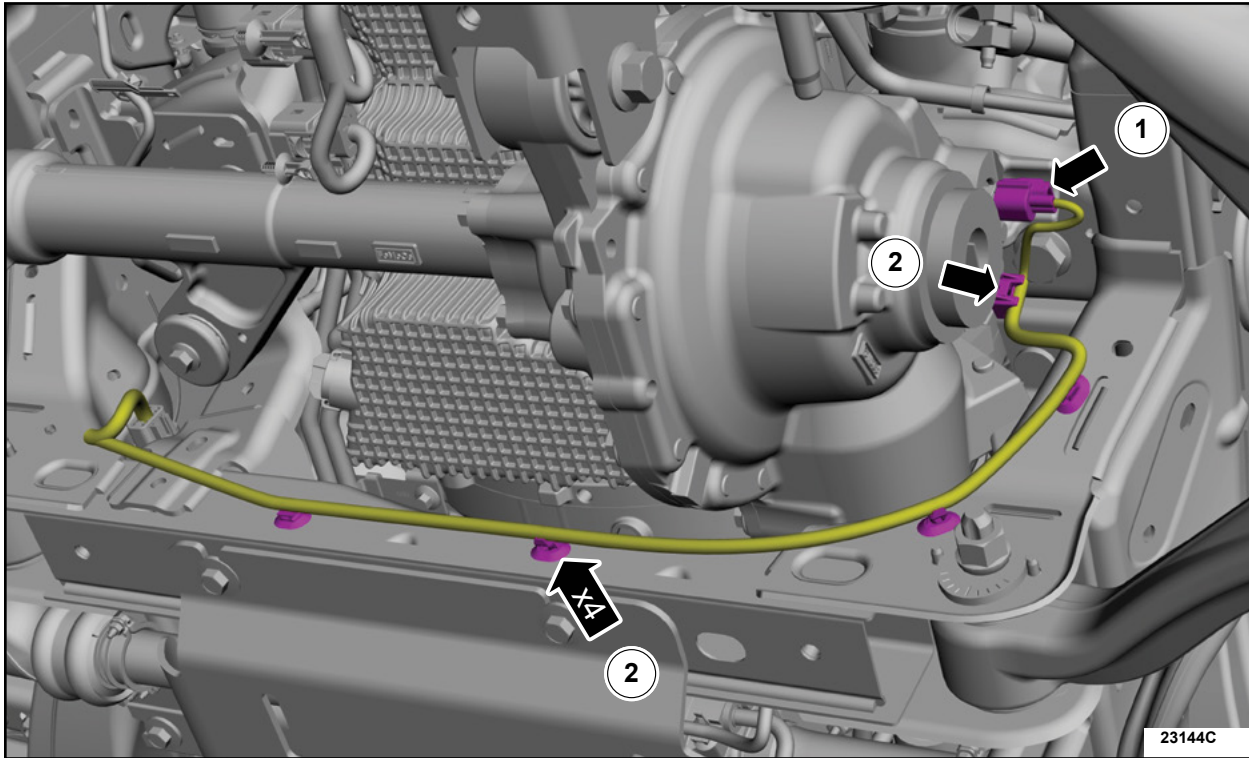

**FIGURE 2**

7. Remove the front driveshaft. Follow the WSM procedures in Section 205-01.
8. Remove both Right Hand (RH) and Left Hand (LH) front halfshafts. Follow the WSM procedures in Section 204-04.



9. Disconnect the Electronic Locking Differential (ELD) electrical connector (1), detach the retainers and position aside the ELD wiring harness (2). See Figure 3.



**FIGURE 3**

10. Remove and discard the front axle carrier mounting bracket bolts. See Figure 4.

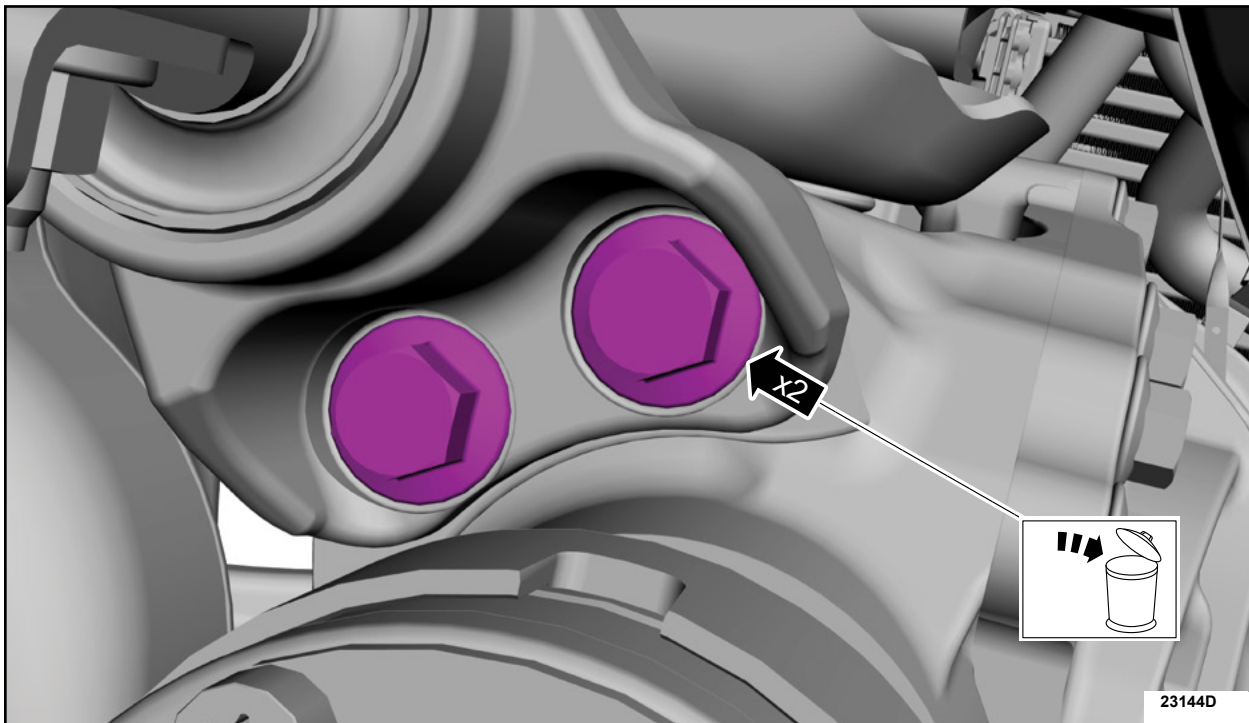

**FIGURE 4**



11. Using transmission jack, support the front axle assembly. See Figure 5.

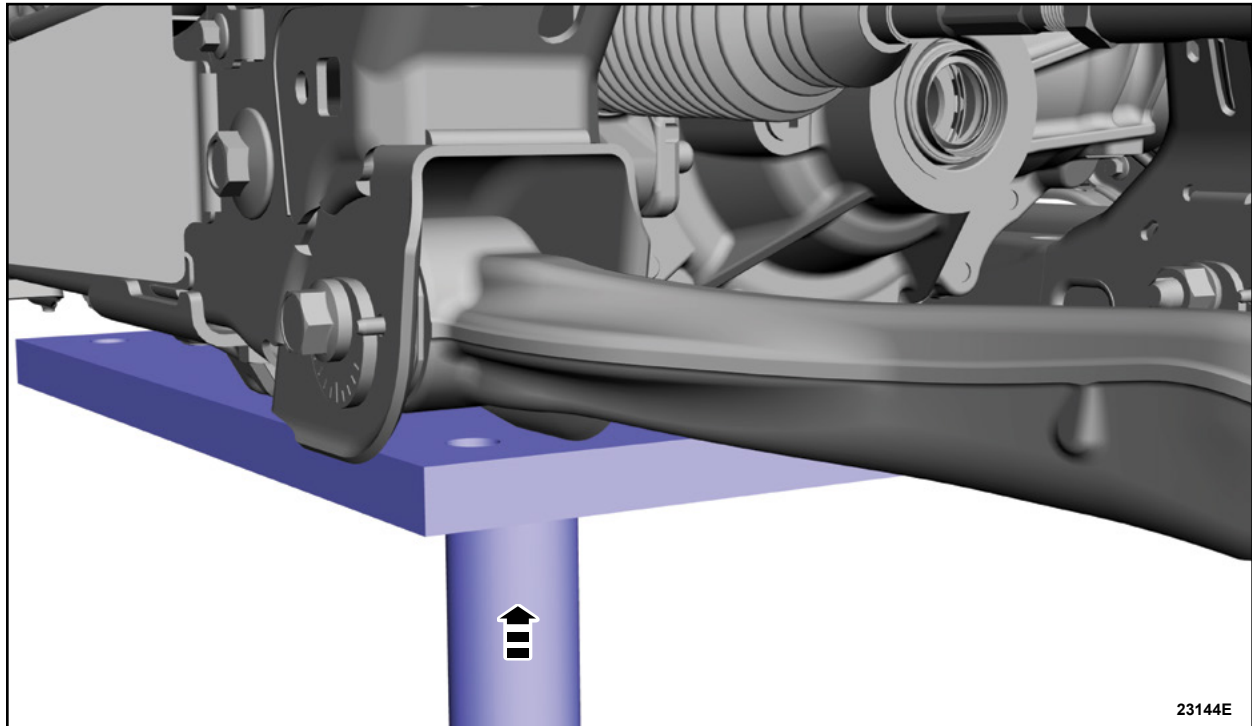

**FIGURE 5**

12. Remove and discard the front axle tube bushing bolt. See Figure 6.

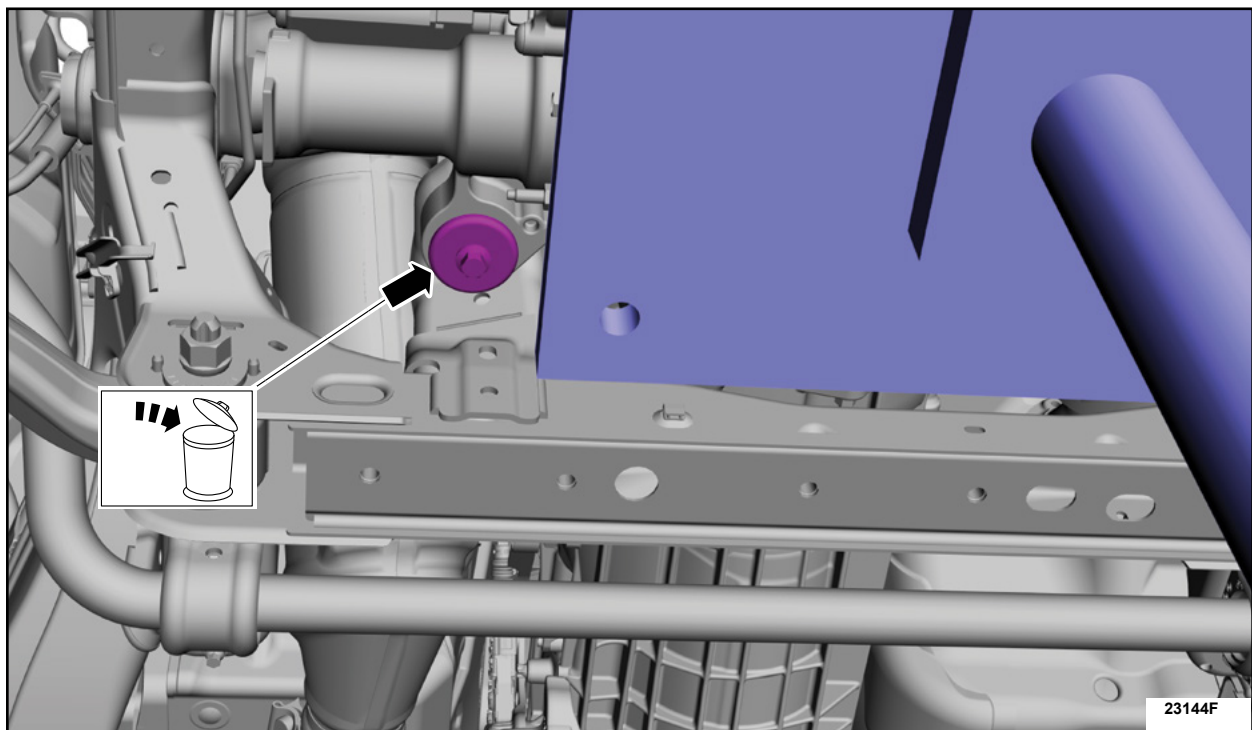

**FIGURE 6**



13. Remove and discard the front axle cover bushing bolt. See Figure 7.

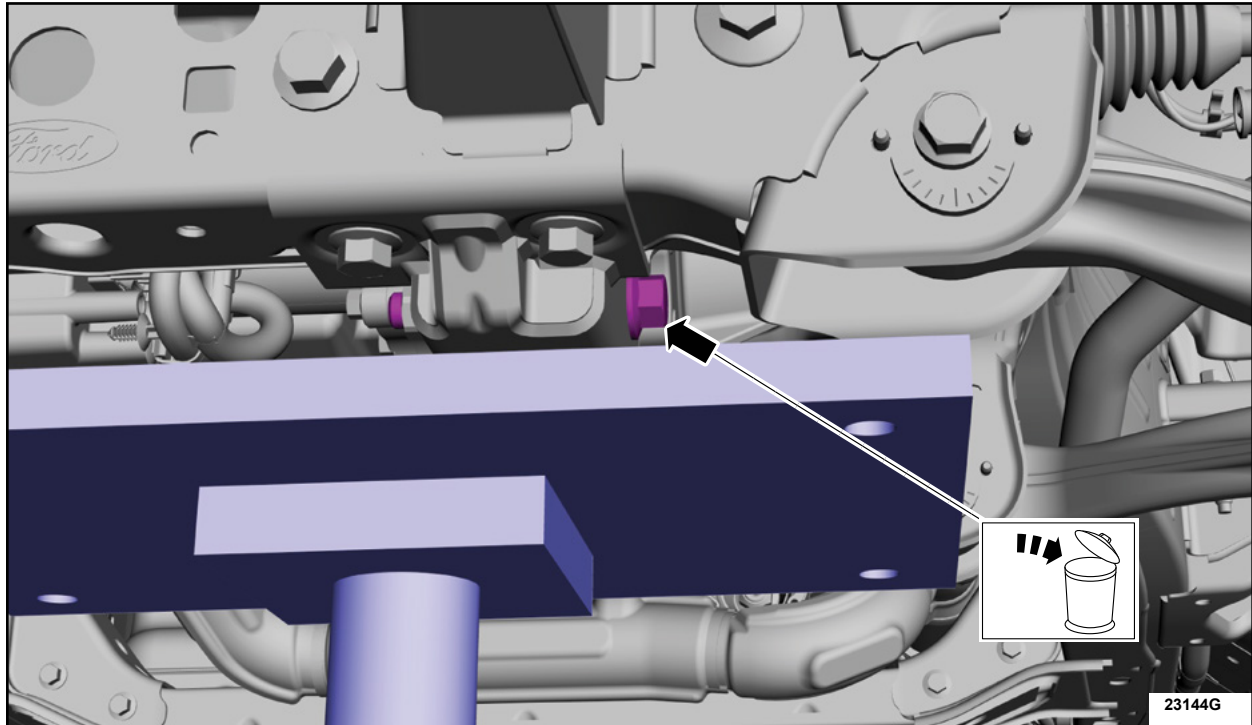

**FIGURE 7**

14. Highlight the installation mark on the breather hose and tube. Detach the breather hose from tube. See Figure 8.

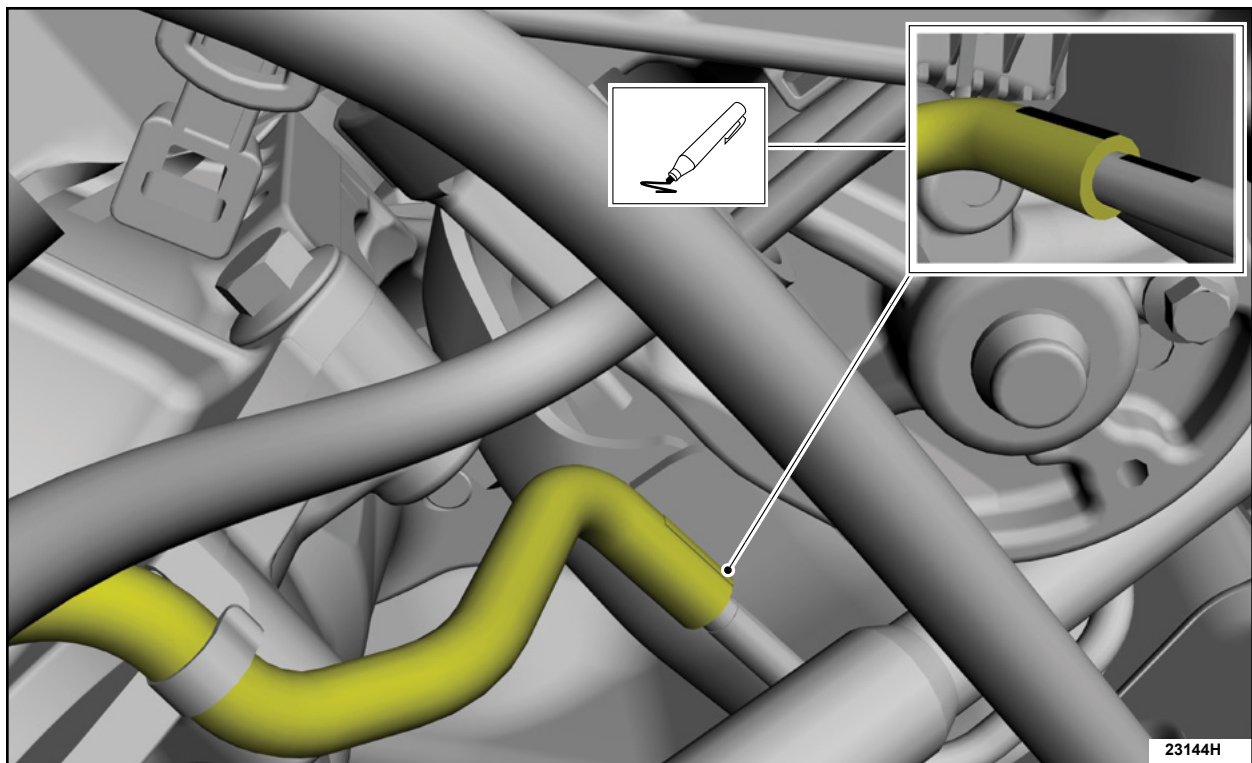

**FIGURE 8**





15. Lower the transmission jack and the front axle assembly. See Figure 9.

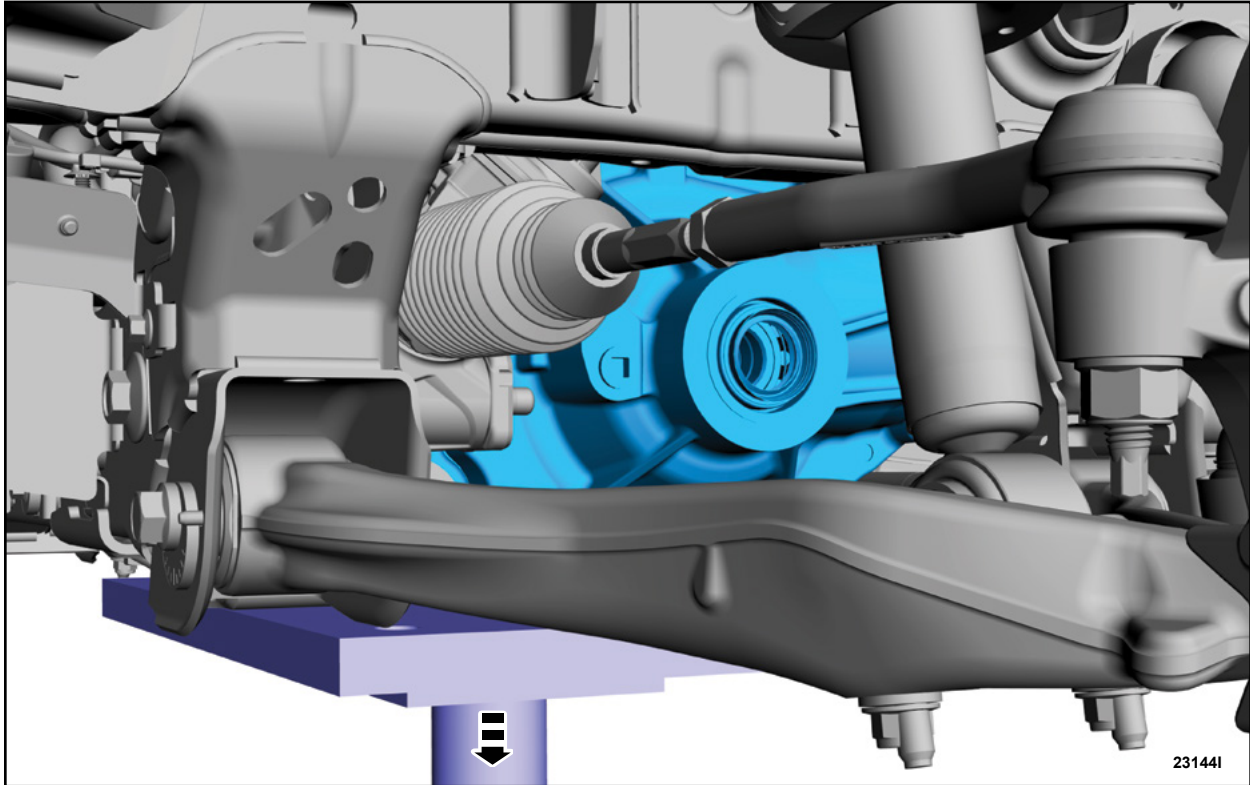

FIGURE 9



**⚠ WARNING:** Do not reuse steering column shaft bolts. This may result in fastener failure and steering column shaft detachment or loss of steering control. Failure to follow this instruction may result in serious injury to vehicle occupant(s).

**NOTICE:** Do not allow the steering wheel to rotate while the steering column shaft is disconnected or damage to the clockspring may result.

16. Remove and discard the steering column shaft coupler retainer (1). Separate the lower steering column shaft from the steering gear (2). See Figure 10.

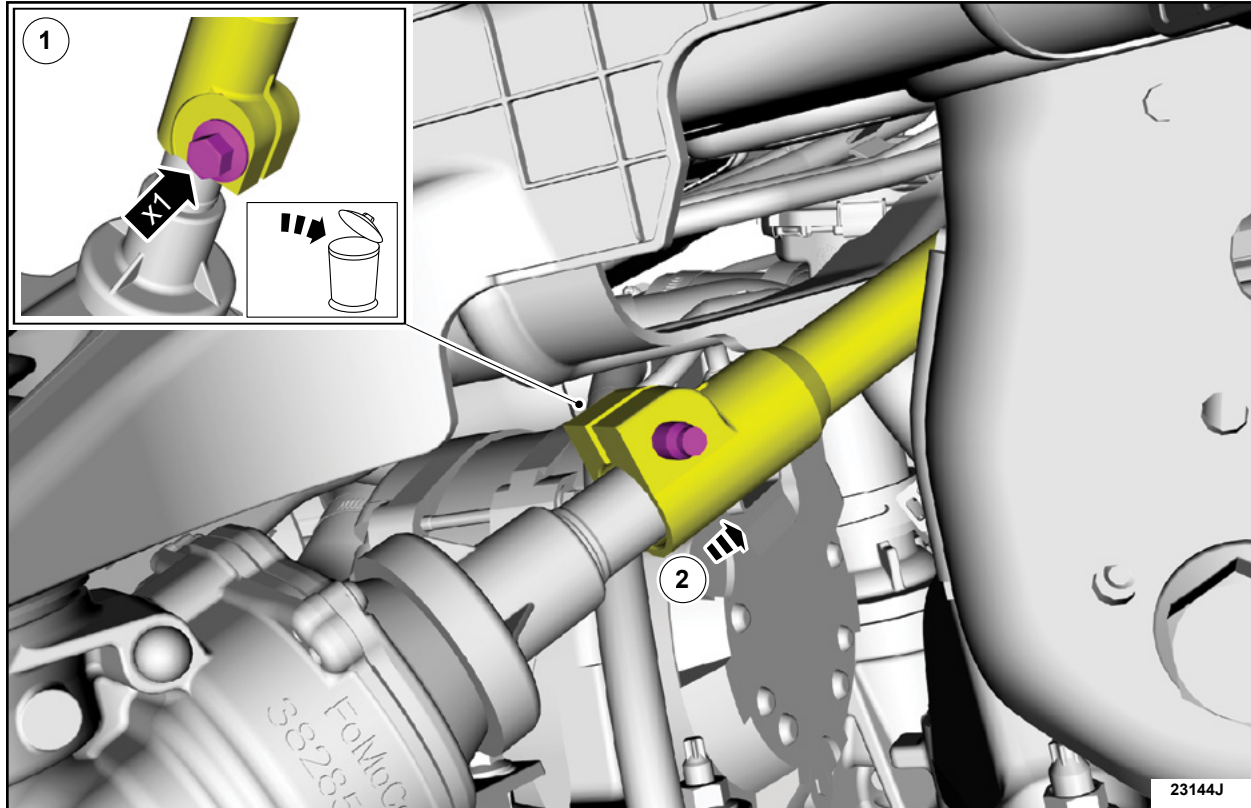
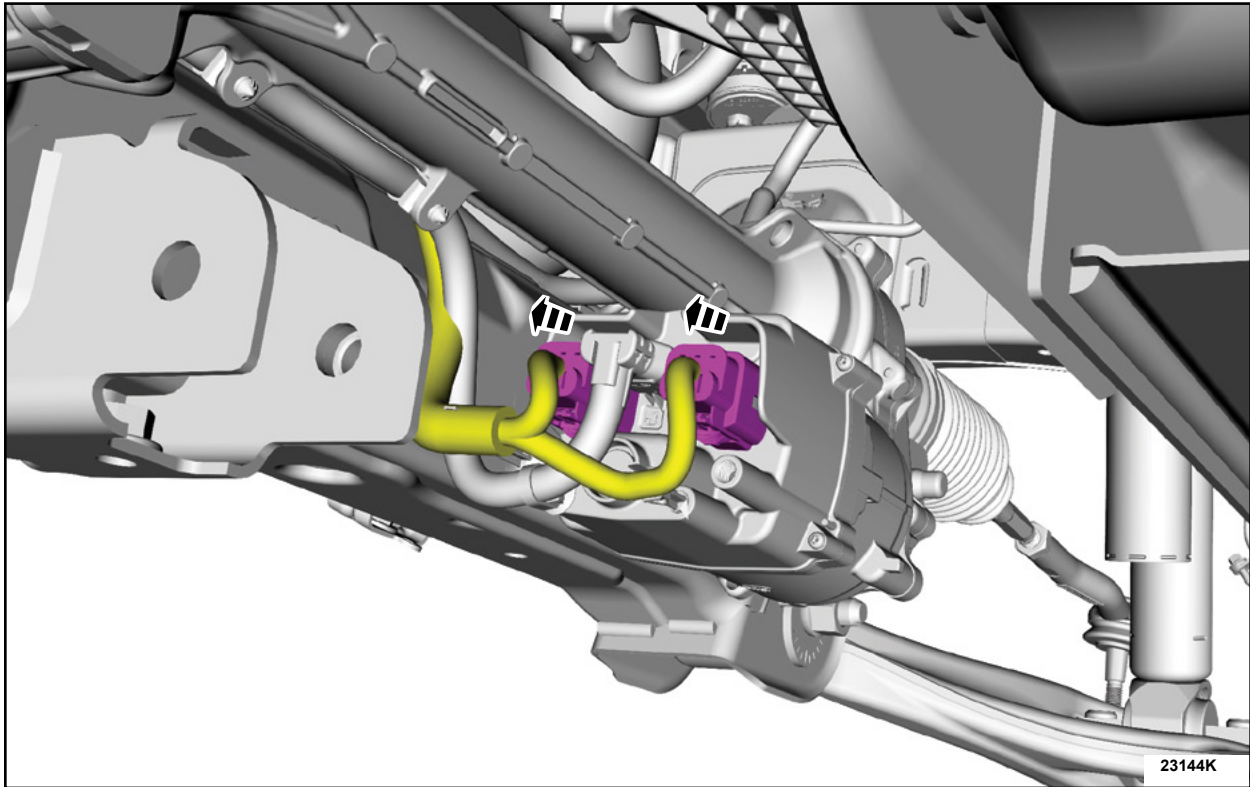

FIGURE 10



17. Disconnect the Electronic Power Assist Steering (EPAS) gear electrical connectors. See Figure 11.



**FIGURE 11**



18. Support the EPAS gear assembly (1). Remove and discard the EPAS gear retainers (2).  
See Figure 12.

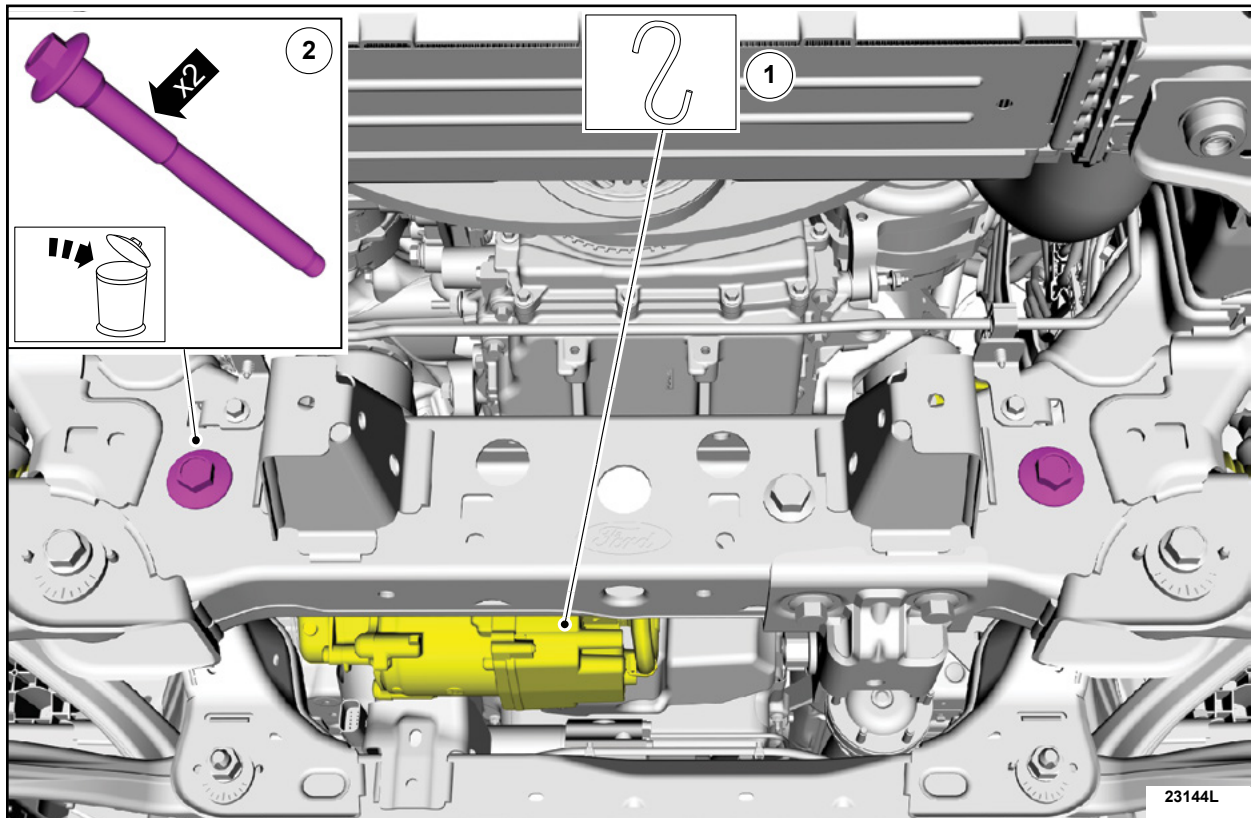
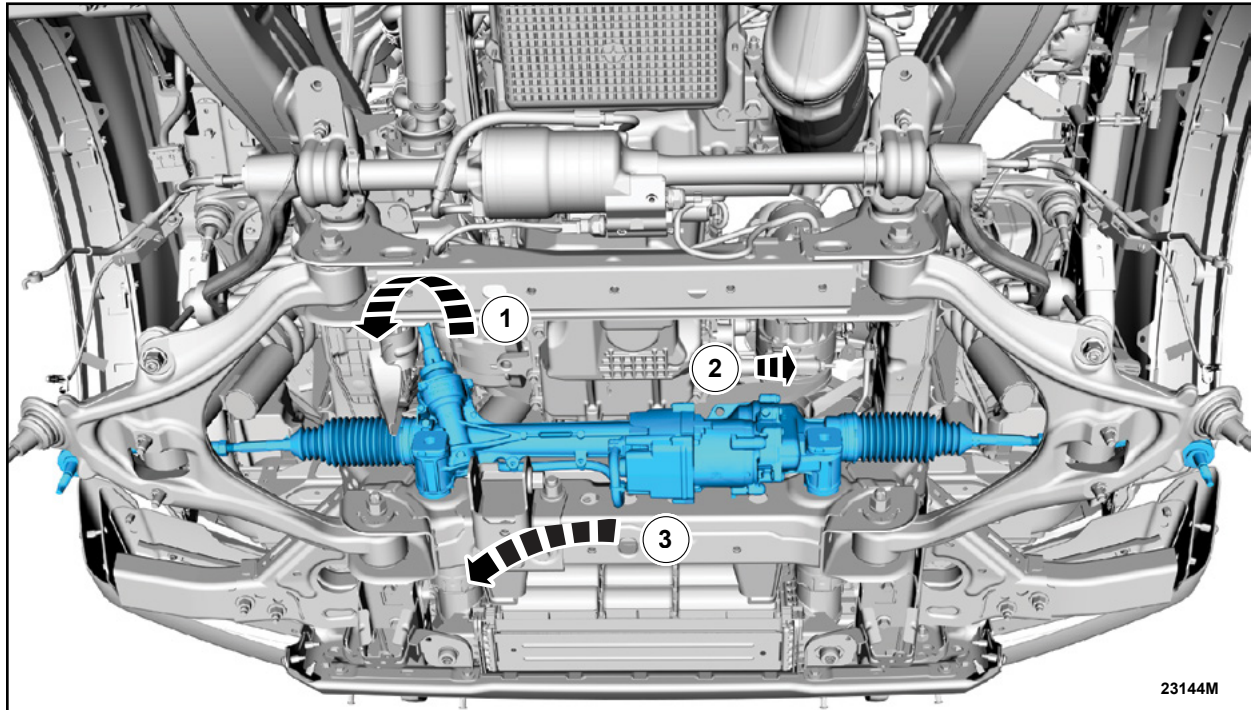

FIGURE 12





19. Rotate the EPAS gear tower downward (1), shift the EPAS gear toward the RH side of the vehicle (2) and remove the EPAS gear (3). See Figure 13.



**FIGURE 13**

20. Install the *new* steering gear. Follow the WSM procedures in Section 211-02.

- It is not necessary to install the LH catalytic converter as it was not removed.

**IMPORTANT NOTE:** Federal law prohibits selling motor vehicle parts or components that are under safety, compliance, or emissions recall. Unless a part is requested to be returned to Ford, all parts replaced under this FSA must be scrapped in accordance with all applicable local, state and federal environmental protection and hazardous material regulations. Refer to the Parts Retention, Return, & Scrapping section of the FSA dealer bulletin for further information.



**NEW VEHICLE DEMONSTRATION / DELIVERY HOLD**  
**\*DO NOT DRIVE VEHICLES\***  
**Safety Recall 23S09**  
 Certain 2022-2023 Bronco - Wildtrak & Raptor Models  
 Steering Gear Replacement

The following table contains a list of affected VINs for FSA 23S09.

**To search for a VIN:**

- Press the Ctrl key and the F key simultaneously, insert the VIN, and then press ENTER.
- Or use the Search Function (magnifier icon) in the Menu bar above.

| VIN               | Country       |
|-------------------|---------------|
| 1FMDE5CP0PLB13668 | United States |
| 1FMDE5CP0PLB19289 | United States |
| 1FMDE5CP1PLB23979 | United States |
| 1FMDE5CP2PLB19648 | United States |
| 1FMDE5CP5PLB19742 | United States |
| 1FMDE5CP6PLB12248 | United States |
| 1FMDE5CP7PLB06507 | United States |
| 1FMDE5CP7PLB19497 | United States |
| 1FMDE5CP7PLB23873 | United States |
| 1FMDE5CP7PLB23985 | United States |
| 1FMDE5CP9PLB11496 | United States |
| 1FMEE5DP0PLB11566 | United States |
| 1FMEE5DP0PLB15391 | United States |
| 1FMEE5DP0PLB15665 | United States |
| 1FMEE5DP0PLB16055 | United States |
| 1FMEE5DP0PLB16234 | United States |
| 1FMEE5DP0PLB16816 | United States |
| 1FMEE5DP0PLB16878 | United States |
| 1FMEE5DP0PLB17349 | United States |
| 1FMEE5DP0PLB17433 | United States |
| 1FMEE5DP0PLB17867 | United States |
| 1FMEE5DP0PLB19053 | United States |
| 1FMEE5DP0PLB19232 | United States |
| 1FMEE5DP0PLB20235 | United States |
| 1FMEE5DP0PLB20641 | United States |
| 1FMEE5DP0PLB21305 | United States |
| 1FMEE5DP1PLA89030 | United States |
| 1FMEE5DP1PLB11432 | United States |

**NEW VEHICLE DEMONSTRATION / DELIVERY HOLD**  
**\*DO NOT DRIVE VEHICLES\***  
**Safety Recall 23S09**  
Certain 2022-2023 Bronco - Wildtrak & Raptor Models  
Steering Gear Replacement

|                   |               |
|-------------------|---------------|
| 1FMEE5DP1PLB11897 | United States |
| 1FMEE5DP1PLB11916 | United States |
| 1FMEE5DP1PLB13262 | United States |
| 1FMEE5DP1PLB15321 | United States |
| 1FMEE5DP1PLB15495 | United States |
| 1FMEE5DP1PLB15772 | United States |
| 1FMEE5DP1PLB15853 | United States |
| 1FMEE5DP1PLB15870 | United States |
| 1FMEE5DP1PLB16212 | United States |
| 1FMEE5DP1PLB16226 | United States |
| 1FMEE5DP1PLB16257 | United States |
| 1FMEE5DP1PLB16291 | United States |
| 1FMEE5DP1PLB17280 | United States |
| 1FMEE5DP1PLB17778 | United States |
| 1FMEE5DP1PLB17795 | United States |
| 1FMEE5DP1PLB17814 | United States |
| 1FMEE5DP1PLB17988 | United States |
| 1FMEE5DP1PLB18087 | United States |
| 1FMEE5DP1PLB18154 | United States |
| 1FMEE5DP1PLB22009 | United States |
| 1FMEE5DP1PLB22379 | United States |
| 1FMEE5DP1PLB22429 | United States |
| 1FMEE5DP2PLB09964 | United States |
| 1FMEE5DP2PLB10080 | United States |
| 1FMEE5DP2PLB10127 | United States |
| 1FMEE5DP2PLB11018 | United States |
| 1FMEE5DP2PLB11150 | United States |
| 1FMEE5DP2PLB11634 | United States |
| 1FMEE5DP2PLB11925 | United States |
| 1FMEE5DP2PLB12038 | United States |
| 1FMEE5DP2PLB13044 | United States |
| 1FMEE5DP2PLB13089 | United States |
| 1FMEE5DP2PLB15148 | United States |
| 1FMEE5DP2PLB15196 | United States |

**NEW VEHICLE DEMONSTRATION / DELIVERY HOLD**

**\*DO NOT DRIVE VEHICLES\***

**Safety Recall 23S09**

Certain 2022-2023 Bronco - Wildtrak & Raptor Models  
Steering Gear Replacement

|                   |               |
|-------------------|---------------|
| 1FMEE5DP2PLB15201 | United States |
| 1FMEE5DP2PLB15313 | United States |
| 1FMEE5DP2PLB15439 | United States |
| 1FMEE5DP2PLB15585 | United States |
| 1FMEE5DP2PLB15845 | United States |
| 1FMEE5DP2PLB16235 | United States |
| 1FMEE5DP2PLB16364 | United States |
| 1FMEE5DP2PLB16896 | United States |
| 1FMEE5DP2PLB17496 | United States |
| 1FMEE5DP2PLB17708 | United States |
| 1FMEE5DP2PLB17868 | United States |
| 1FMEE5DP2PLB18129 | United States |
| 1FMEE5DP2PLB19023 | United States |
| 1FMEE5DP2PLB19653 | United States |
| 1FMEE5DP2PLB19927 | United States |
| 1FMEE5DP2PLB20611 | United States |
| 1FMEE5DP2PLB21841 | United States |
| 1FMEE5DP2PLB21855 | United States |
| 1FMEE5DP2PLB22021 | United States |
| 1FMEE5DP2PLB22083 | United States |
| 1FMEE5DP3PLB06491 | United States |
| 1FMEE5DP3PLB09648 | United States |
| 1FMEE5DP3PLB10248 | United States |
| 1FMEE5DP3PLB10721 | United States |
| 1FMEE5DP3PLB11156 | United States |
| 1FMEE5DP3PLB11416 | United States |
| 1FMEE5DP3PLB11450 | United States |
| 1FMEE5DP3PLB12324 | United States |
| 1FMEE5DP3PLB12369 | United States |
| 1FMEE5DP3PLB15353 | United States |
| 1FMEE5DP3PLB15546 | United States |
| 1FMEE5DP3PLB15918 | United States |
| 1FMEE5DP3PLB16387 | United States |
| 1FMEE5DP3PLB16714 | United States |

**NEW VEHICLE DEMONSTRATION / DELIVERY HOLD**  
**\*DO NOT DRIVE VEHICLES\***  
**Safety Recall 23S09**  
Certain 2022-2023 Bronco - Wildtrak & Raptor Models  
Steering Gear Replacement

|                   |               |
|-------------------|---------------|
| 1FMEE5DP3PLB16826 | United States |
| 1FMEE5DP3PLB17992 | United States |
| 1FMEE5DP3PLB18110 | United States |
| 1FMEE5DP3PLB19032 | United States |
| 1FMEE5DP3PLB20732 | United States |
| 1FMEE5DP3PLB22271 | United States |
| 1FMEE5DP3PLB22335 | United States |
| 1FMEE5DP4PLB07326 | United States |
| 1FMEE5DP4PLB09867 | United States |
| 1FMEE5DP4PLB10890 | United States |
| 1FMEE5DP4PLB11294 | United States |
| 1FMEE5DP4PLB11358 | United States |
| 1FMEE5DP4PLB11490 | United States |
| 1FMEE5DP4PLB15118 | United States |
| 1FMEE5DP4PLB15233 | United States |
| 1FMEE5DP4PLB15300 | United States |
| 1FMEE5DP4PLB15510 | United States |
| 1FMEE5DP4PLB15801 | United States |
| 1FMEE5DP4PLB15989 | United States |
| 1FMEE5DP4PLB16012 | United States |
| 1FMEE5DP4PLB16026 | United States |
| 1FMEE5DP4PLB16169 | United States |
| 1FMEE5DP4PLB17533 | United States |
| 1FMEE5DP4PLB18049 | United States |
| 1FMEE5DP4PLB18181 | United States |
| 1FMEE5DP4PLB20304 | United States |
| 1FMEE5DP4PLB20397 | United States |
| 1FMEE5DP4PLB20609 | United States |
| 1FMEE5DP5PLA88804 | United States |
| 1FMEE5DP5PLB10879 | United States |
| 1FMEE5DP5PLB11112 | United States |
| 1FMEE5DP5PLB15130 | United States |
| 1FMEE5DP5PLB15161 | United States |
| 1FMEE5DP5PLB15192 | United States |

**NEW VEHICLE DEMONSTRATION / DELIVERY HOLD**

**\*DO NOT DRIVE VEHICLES\***

**Safety Recall 23S09**

Certain 2022-2023 Bronco - Wildtrak & Raptor Models  
Steering Gear Replacement

|                   |               |
|-------------------|---------------|
| 1FMEE5DP5PLB15208 | United States |
| 1FMEE5DP5PLB15306 | United States |
| 1FMEE5DP5PLB15368 | United States |
| 1FMEE5DP5PLB15581 | United States |
| 1FMEE5DP5PLB16133 | United States |
| 1FMEE5DP5PLB16228 | United States |
| 1FMEE5DP5PLB16293 | United States |
| 1FMEE5DP5PLB16312 | United States |
| 1FMEE5DP5PLB16617 | United States |
| 1FMEE5DP5PLB16763 | United States |
| 1FMEE5DP5PLB16990 | United States |
| 1FMEE5DP5PLB17265 | United States |
| 1FMEE5DP5PLB18089 | United States |
| 1FMEE5DP5PLB18173 | United States |
| 1FMEE5DP5PLB18352 | United States |
| 1FMEE5DP5PLB19002 | United States |
| 1FMEE5DP5PLB19100 | United States |
| 1FMEE5DP5PLB20134 | United States |
| 1FMEE5DP5PLB21218 | United States |
| 1FMEE5DP5PLB21980 | United States |
| 1FMEE5DP5PLB22076 | United States |
| 1FMEE5DP5PLB22336 | United States |
| 1FMEE5DP5PLB22370 | United States |
| 1FMEE5DP6PLB09272 | United States |
| 1FMEE5DP6PLB10325 | United States |
| 1FMEE5DP6PLB10955 | United States |
| 1FMEE5DP6PLB11751 | United States |
| 1FMEE5DP6PLB12401 | United States |
| 1FMEE5DP6PLB13144 | United States |
| 1FMEE5DP6PLB15153 | United States |
| 1FMEE5DP6PLB15282 | United States |
| 1FMEE5DP6PLB15315 | United States |
| 1FMEE5DP6PLB15525 | United States |
| 1FMEE5DP6PLB15606 | United States |

**NEW VEHICLE DEMONSTRATION / DELIVERY HOLD**  
**\*DO NOT DRIVE VEHICLES\***  
**Safety Recall 23S09**  
Certain 2022-2023 Bronco - Wildtrak & Raptor Models  
Steering Gear Replacement

|                   |               |
|-------------------|---------------|
| 1FMEE5DP6PLB15623 | United States |
| 1FMEE5DP6PLB16187 | United States |
| 1FMEE5DP6PLB16299 | United States |
| 1FMEE5DP6PLB16643 | United States |
| 1FMEE5DP6PLB17470 | United States |
| 1FMEE5DP6PLB17713 | United States |
| 1FMEE5DP6PLB18182 | United States |
| 1FMEE5DP6PLB18988 | United States |
| 1FMEE5DP6PLB19316 | United States |
| 1FMEE5DP6PLB19591 | United States |
| 1FMEE5DP6PLB20031 | United States |
| 1FMEE5DP6PLB20093 | United States |
| 1FMEE5DP6PLB20952 | United States |
| 1FMEE5DP6PLB20997 | United States |
| 1FMEE5DP7PLA88688 | United States |
| 1FMEE5DP7PLB06929 | United States |
| 1FMEE5DP7PLB08812 | United States |
| 1FMEE5DP7PLB11046 | United States |
| 1FMEE5DP7PLB11256 | United States |
| 1FMEE5DP7PLB11886 | United States |
| 1FMEE5DP7PLB15131 | United States |
| 1FMEE5DP7PLB15243 | United States |
| 1FMEE5DP7PLB15498 | United States |
| 1FMEE5DP7PLB15517 | United States |
| 1FMEE5DP7PLB15811 | United States |
| 1FMEE5DP7PLB15839 | United States |
| 1FMEE5DP7PLB15971 | United States |
| 1FMEE5DP7PLB15985 | United States |
| 1FMEE5DP7PLB16019 | United States |
| 1FMEE5DP7PLB16439 | United States |
| 1FMEE5DP7PLB16618 | United States |
| 1FMEE5DP7PLB16652 | United States |
| 1FMEE5DP7PLB17087 | United States |
| 1FMEE5DP7PLB17249 | United States |



**NEW VEHICLE DEMONSTRATION / DELIVERY HOLD**

**\*DO NOT DRIVE VEHICLES\***

**Safety Recall 23S09**

Certain 2022-2023 Bronco - Wildtrak & Raptor Models  
Steering Gear Replacement

|                   |               |
|-------------------|---------------|
| 1FMEE5DP7PLB17333 | United States |
| 1FMEE5DP7PLB17400 | United States |
| 1FMEE5DP7PLB17431 | United States |
| 1FMEE5DP7PLB17610 | United States |
| 1FMEE5DP7PLB18398 | United States |
| 1FMEE5DP7PLB19602 | United States |
| 1FMEE5DP7PLB20149 | United States |
| 1FMEE5DP7PLB20569 | United States |
| 1FMEE5DP7PLB20829 | United States |
| 1FMEE5DP7PLB21897 | United States |
| 1FMEE5DP7PLB22130 | United States |
| 1FMEE5DP7PLB22337 | United States |
| 1FMEE5DP7PLB22399 | United States |
| 1FMEE5DP7PLB32611 | United States |
| 1FMEE5DP8PLB09967 | United States |
| 1FMEE5DP8PLB11329 | United States |
| 1FMEE5DP8PLB11332 | United States |
| 1FMEE5DP8PLB12030 | United States |
| 1FMEE5DP8PLB13274 | United States |
| 1FMEE5DP8PLB15302 | United States |
| 1FMEE5DP8PLB15543 | United States |
| 1FMEE5DP8PLB15705 | United States |
| 1FMEE5DP8PLB15834 | United States |
| 1FMEE5DP8PLB15896 | United States |
| 1FMEE5DP8PLB15977 | United States |
| 1FMEE5DP8PLB16028 | United States |
| 1FMEE5DP8PLB16143 | United States |
| 1FMEE5DP8PLB16904 | United States |
| 1FMEE5DP8PLB16949 | United States |
| 1FMEE5DP8PLB17633 | United States |
| 1FMEE5DP8PLB17924 | United States |
| 1FMEE5DP8PLB19981 | United States |
| 1FMEE5DP8PLB21455 | United States |
| 1FMEE5DP8PLB21889 | United States |



**NEW VEHICLE DEMONSTRATION / DELIVERY HOLD**

**\*DO NOT DRIVE VEHICLES\***

**Safety Recall 23S09**

Certain 2022-2023 Bronco - Wildtrak & Raptor Models  
Steering Gear Replacement

|                   |               |
|-------------------|---------------|
| 1FMEE5DP8PLB22007 | United States |
| 1FMEE5DP8PLB22363 | United States |
| 1FMEE5DP8PLB22394 | United States |
| 1FMEE5DP8PLB22444 | United States |
| 1FMEE5DP9PLB11498 | United States |
| 1FMEE5DP9PLB12652 | United States |
| 1FMEE5DP9PLB15714 | United States |
| 1FMEE5DP9PLB15924 | United States |
| 1FMEE5DP9PLB16118 | United States |
| 1FMEE5DP9PLB16331 | United States |
| 1FMEE5DP9PLB18127 | United States |
| 1FMEE5DP9PLB19455 | United States |
| 1FMEE5DP9PLB19522 | United States |
| 1FMEE5DP9PLB19715 | United States |
| 1FMEE5DP9PLB19939 | United States |
| 1FMEE5DP9PLB22288 | United States |
| 1FMEE5DP9PLB22338 | United States |
| 1FMEE5DPXPLA89379 | United States |
| 1FMEE5DPXPLB06178 | United States |
| 1FMEE5DPXPLB07511 | United States |
| 1FMEE5DPXPLB08593 | United States |
| 1FMEE5DPXPLB09551 | United States |
| 1FMEE5DPXPLB11641 | United States |
| 1FMEE5DPXPLB13180 | United States |
| 1FMEE5DPXPLB15124 | United States |
| 1FMEE5DPXPLB15138 | United States |
| 1FMEE5DPXPLB15172 | United States |
| 1FMEE5DPXPLB15284 | United States |
| 1FMEE5DPXPLB15575 | United States |
| 1FMEE5DPXPLB15950 | United States |
| 1FMEE5DPXPLB16130 | United States |
| 1FMEE5DPXPLB16192 | United States |
| 1FMEE5DPXPLB16404 | United States |
| 1FMEE5DPXPLB17407 | United States |

**NEW VEHICLE DEMONSTRATION / DELIVERY HOLD**  
**\*DO NOT DRIVE VEHICLES\***  
**Safety Recall 23S09**  
Certain 2022-2023 Bronco - Wildtrak & Raptor Models  
Steering Gear Replacement

|                   |               |
|-------------------|---------------|
| 1FMEE5DPXPLB18203 | United States |
| 1FMEE5DPXPLB18251 | United States |
| 1FMEE5DPXPLB18394 | United States |
| 1FMEE5DPXPLB19724 | United States |
| 1FMEE5DPXPLB20212 | United States |
| 1FMEE5DPXPLB21327 | United States |
| 1FMEE5DPXPLB22056 | United States |
| 1FMEE5DPXPLB22249 | United States |
| 1FMEE5DPXPLB22445 | United States |
| 1FMEE5JR0NLA51372 | United States |
| 1FMEE5JR0NLA51419 | United States |
| 1FMEE5JR0NLA51582 | United States |
| 1FMEE5JR0NLA52232 | United States |
| 1FMEE5JR0PLA80485 | United States |
| 1FMEE5JR0PLA81197 | United States |
| 1FMEE5JR1NLA51350 | United States |
| 1FMEE5JR1NLA51381 | United States |
| 1FMEE5JR1NLA51395 | United States |
| 1FMEE5JR1NLA51607 | United States |
| 1FMEE5JR1NLA51817 | United States |
| 1FMEE5JR1NLA51879 | United States |
| 1FMEE5JR1PLA80270 | United States |
| 1FMEE5JR1PLA80575 | United States |
| 1FMEE5JR1PLA80768 | United States |
| 1FMEE5JR2NLA51423 | United States |
| 1FMEE5JR2NLA51518 | United States |
| 1FMEE5JR2NLA51549 | United States |
| 1FMEE5JR2NLA51650 | United States |
| 1FMEE5JR2PLA80309 | United States |
| 1FMEE5JR2PLA80312 | United States |
| 1FMEE5JR2PLA80570 | United States |
| 1FMEE5JR2PLA81038 | United States |
| 1FMEE5JR3NLA51480 | United States |
| 1FMEE5JR3PLA80271 | United States |

**NEW VEHICLE DEMONSTRATION / DELIVERY HOLD**

**\*DO NOT DRIVE VEHICLES\***

**Safety Recall 23S09**

Certain 2022-2023 Bronco - Wildtrak & Raptor Models  
Steering Gear Replacement

|                   |               |
|-------------------|---------------|
| 1FMEE5JR3PLA80335 | United States |
| 1FMEE5JR3PLA81050 | United States |
| 1FMEE5JR4NLA51407 | United States |
| 1FMEE5JR4PLA80716 | United States |
| 1FMEE5JR5NLA50587 | United States |
| 1FMEE5JR5PLA80336 | United States |
| 1FMEE5JR5PLA80501 | United States |
| 1FMEE5JR6NLA50629 | United States |
| 1FMEE5JR6PLA80331 | United States |
| 1FMEE5JR6PLA80538 | United States |
| 1FMEE5JR6PLA80992 | United States |
| 1FMEE5JR7NLA50784 | United States |
| 1FMEE5JR7NLA51420 | United States |
| 1FMEE5JR7NLA51465 | United States |
| 1FMEE5JR7PLA80306 | United States |
| 1FMEE5JR7PLA80614 | United States |
| 1FMEE5JR7PLA80726 | United States |
| 1FMEE5JR8NLA50650 | United States |
| 1FMEE5JR8NLA51653 | United States |
| 1FMEE5JR8NLA51765 | United States |
| 1FMEE5JR8NLA51880 | United States |
| 1FMEE5JR8PLA80279 | United States |
| 1FMEE5JR8PLA80296 | United States |
| 1FMEE5JR8PLA80329 | United States |
| 1FMEE5JR8PLA80394 | United States |
| 1FMEE5JR8PLA89581 | United States |
| 1FMEE5JR9NLA51404 | United States |
| 1FMEE5JR9NLA51791 | United States |
| 1FMEE5JR9NLA51984 | United States |
| 1FMEE5JR9PLA80470 | United States |
| 1FMEE5JRXNLA51363 | United States |
| 1FMEE5JRXNLA51461 | United States |
| 1FMEE5JRXNLA51816 | United States |
| 1FMEE5JRXPLA80526 | United States |

**NEW VEHICLE DEMONSTRATION / DELIVERY HOLD**  
**\*DO NOT DRIVE VEHICLES\***  
**Safety Recall 23S09**  
Certain 2022-2023 Bronco - Wildtrak & Raptor Models  
Steering Gear Replacement

|                   |               |
|-------------------|---------------|
| 1FMEE5JRXPLA80543 | United States |
| 1FMEE5DP1PLB21975 | Saudi Arabia  |
| 1FMEE5DP6PLB12284 | Saudi Arabia  |
| 1FMEE5DP7PLB10687 | Saudi Arabia  |
| 1FMEE5DP7PLB10771 | Saudi Arabia  |
| 1FMEE5DP8PLB13159 | Saudi Arabia  |
| 1FMDE5CP2PLB12702 | Canada        |
| 1FMEE5DP1PLB12287 | Canada        |
| 1FMEE5DP2PLB08717 | Canada        |

**Ford Motor Company**  
**Recall Reimbursement Plan for 23S09**

*Ford and Lincoln dealers are in the best position to quickly and efficiently process reimbursement requests. However, federal legislation requires all motor vehicle manufacturers to establish processes through which customers may seek recall reimbursement directly from the manufacturer or the dealers.*

*Regarding the specific reimbursement plan for Recall # 23S09, owners who have paid for service to remedy the defect or noncompliance must have had that service performed before April 7, 2023. After this date, if repairs related to this recall are performed by a non-Ford repair facility in an emergency, customers must submit any refund requests through their dealership. As required by this federal regulation, Ford Motor Company submitted the details of its latest General Recall Reimbursement Plan in a letter to the National Highway Traffic Safety Administration (NHTSA) in May 2021. The following is the text of that letter and the Plan:*

**General Recall Reimbursement Plan**  
(As submitted to the NHTSA)

Under the requirements outlined in 49 CFR Part 573 and Part 577 of the Code of Federal Regulations, Ford Motor Company (Ford) is submitting the required information about our general reimbursement plan for the cost of remedies paid for by vehicle owners before they are notified of a related safety recall.

Set forth below is Ford's general plan to reimburse owners and purchasers for costs incurred for remedies in advance of notification of potential safety-related defects or noncompliance according to Part 573.6 (c)(8)(i). This plan has not changed since our February 20, 2019 submission.

**Reimbursement Notification**

Ford's notice to a vehicle owner in accordance with 49 CFR Part 577 will indicate that Ford is offering a refund if the owner paid to have service to remedy the defect or noncompliance before a specified ending date. In accordance with Part 573.13 (c)(2), this ending date will be defined as a minimum of ten calendar days after the date on which Ford mailed the last of its Part 577 notifications to owners, and will be indicated in the specific reimbursement plan available to owners for an individual recall. This notice will direct owners to seek eligible reimbursement through authorized dealers or, at their option, directly through Ford at the following address:

Ford Motor Company  
P.O. Box 6251  
Dearborn, MI 48121-6251

Ford notes that this rule allows for the identification of a beginning date for reimbursement eligibility. Under the rule, an owner who paid to remedy the defect or noncompliance before the identified beginning date would not be eligible for reimbursement. Ford generally has not established such a beginning date for reimbursement eligibility and does not presently anticipate changing this general policy. However, in any case, where Ford determines a beginning date is appropriate, Ford will indicate that date in the owner's notice. As permitted by 577.11(e), Ford may not include a reimbursement notification when all vehicles are well within the warranty period, subject to approval by the agency.

## **Costs to be Reimbursed**

For vehicles, reimbursement will not be less than the lesser of:

- The amount paid by the owner for the remedy that specifically addressed and was reasonably necessary to correct the defect or noncompliance that is the subject of the recall, or
- The cost of parts for the remedy (to be no more than the manufacturer's list retail price for authorized part(s), plus associated labor at local labor rates, miscellaneous fees (such as disposal of waste), and taxes.

For replacement equipment, reimbursement will be the amount paid by the owner for the replacement item (limited by the amount of the retail list price of the defective or noncompliant item that was replaced, plus taxes, where the brand or model purchased by the owner was different from the brand or model that was the subject of the recall). If the item of motor vehicle equipment was repaired, the reimbursement provisions identified above for vehicles will apply.

Ford notes that costs incurred by the owner within the period during which Ford's original or extended warranty would have provided for a free repair of the problem will not be eligible for reimbursement, as provided by Part 573.13 (d)(1).

### Entities Authorized to Provide Reimbursement

Ford will continue to use authorized dealers to reimburse owners under the specific reimbursement plans for a particular recall and will encourage owners to pursue requests for reimbursement directly through dealers to expedite reimbursement. Ford will also provide a mailing address to which customers can, at their option, send requests for reimbursement directly to Ford, as previously noted. Requests for reimbursement sent directly to Ford may take up to 60 days to process. Whether the owner chooses to pursue reimbursement requests through a dealer or directly through Ford, the owner will be directed to submit the required documentation, upon which reimbursement eligibility will be determined.

## **Required Documentation**

The reimbursement determination will depend upon the information provided by the customer. Consistent with Part 573.13 (d)(4) the following information must be submitted:

- Claimant's name and address.
- Vehicle make, model, and model year.
- Vehicle identification number (VIN) and, for replacement equipment, a description of such equipment or, for tires, the model, size, and TIN (DOT code).
- Identification of the recall number (either the Ford recall number or the NHTSA recall number).
- Identification of the owner of the recalled vehicle at the time that the pre-notification remedy was obtained.
- An original receipt for the pre-notification remedy that includes a breakdown of the amount for parts, labor, other costs, and taxes, including costs for the replacement item. Where the receipt covers work other than to address the recall or noncompliance, Ford may require the claimant to separately identify costs that are eligible for reimbursement.
- If the remedy was obtained during the warranty period, documentation indicating that the warranty was not honored or the warranty repair did not correct the problem related to the recall.

Failure to submit all of the above information may result in the denial of the reimbursement request.

**Additional Information**

The Part 577 required owner notice will provide a toll-free telephone number through which specific information about the reimbursement plan can be requested from Ford. This general reimbursement plan will be incorporated into notifications according to Part 573.6 by reference. Information specific to an individual recall also may be incorporated into the Part 573.6 notification.