



Stacy L. Balzer  
 Operating Director  
 Service Engineering Operations  
 Ford Customer Service Division

Ford Motor Company  
 P. O. Box 1904  
 Dearborn, Michigan 48121

April 13, 2023

**TO:** All U.S. Ford and Lincoln Dealers

**SUBJECT:** **NEW VEHICLE DEMONSTRATION / DELIVERY HOLD - Safety Recall 23S01**  
 Certain 2023 Model Year Bronco Sport Vehicles Equipped with a Vacuum Brake Booster  
 Anti-Lock Brake (ABS) System Hydraulic Control Unit (HCU) Replacement

**REF:** NEW VEHICLE DEMONSTRATION / DELIVERY HOLD – Advance Notice  
 Safety Recall 23S01  
 Dated: January 30, 2023

**AFFECTED VEHICLES**

Vehicle	Model Year	Assembly Plant	Build Dates
Bronco Sport	2023	Hermosillo	December 8, 2022 through December 16, 2022

US population of affected vehicles: 801. Affected vehicles are identified in OASIS and FSA VIN Lists.

**REASON FOR THIS SAFETY RECALL**

In the affected vehicles, the HCU may have an internal leak in the normally closed valve due to a flat spot on the ball of the armature assembly. An internally leaking HCU could cause longer brake pedal travel without any visual or audible warnings. This condition may be intermittent, resulting in inconsistent pedal travel. Additionally, the driver selectable Auto Vehicle Hold feature may not operate as intended if a leak is present in the rear normally closed valves. The vehicle may creep unexpectedly after an auto hold event is initiated.

**SERVICE ACTION**

Before demonstrating or delivering any new in-stock vehicles involved in this recall, dealers are to replace the HCU. This service must be performed on all affected vehicles at no charge to the vehicle owner.

**OWNER NOTIFICATION MAILING SCHEDULE**

Owner letters are expected to be mailed the week of April 24, 2023. Dealers should repair any affected vehicles that arrive at their dealerships, whether or not the customer has received a letter.

**PLEASE NOTE:**

**Federal law requires dealers to complete this recall service before a new vehicle is delivered to the buyer or lessee. Violation of this requirement by a dealer could result in a civil penalty of up to \$26,315 per vehicle. Correct all vehicles in your new vehicle inventory before delivery.**

**ATTACHMENTS**

- Attachment I: Administrative Information
- Attachment II: Labor Allowances and Parts Ordering Information
- Attachment III: Technical Information
- Owner Notification Letters
- Recall Reimbursement Plan

**QUESTIONS & ASSISTANCE**

For questions and assistance, contact the Special Service Support Center (SSSC) via the SSSC Web Contact Site. The SSSC Web Contact Site can be accessed through the Professional Technician System (PTS) website using the SSSC link listed at the bottom of the OASIS VIN report screen or listed under the SSSC tab.

Sincerely,

Stacy L. Balzer

**NEW VEHICLE DEMONSTRATION / DELIVERY HOLD - Safety Recall 23S01**  
Certain 2023 Model Year Bronco Sport Vehicles Equipped with a Vacuum Brake Booster  
Anti-Lock Brake (ABS) System Hydraulic Control Unit (HCU) Replacement

**OASIS ACTIVATION**

OASIS was activated on January 30, 2023.

**FSA VIN LISTS ACTIVATION**

FSA VIN Lists were available through <https://web.fsavinlists.dealerconnection.com> on January 30, 2023. Owner names and addresses will be available by May 12, 2023.

**NOTE:** Your FSA VIN Lists may contain owner names and addresses obtained from motor vehicle registration records. The use of such motor vehicle registration data for any purpose other than in connection with this recall is a violation of law in several states, provinces, and countries. Accordingly, you must limit the use of this listing to the follow-up necessary to complete this recall.

**SOLD VEHICLES**

- Ford has not issued instructions to stop selling/delivering or driving used vehicles under this safety recall. Owners should contact their dealers for an appointment to have their vehicles remedied as soon as practicable.
- Immediately contact any of your affected customers whose vehicles are not on your VIN list but are identified in OASIS. Give the customer a copy of the Owner Notification Letter (when available) and schedule a service date.
- Correct other affected vehicles identified in OASIS which are brought to your dealership.
- Dealers are to prioritize repairs of customer vehicles over repairs of new and used vehicle inventory.

**STOCK VEHICLES**

- Correct all affected units in your new vehicle inventory before delivery.
- Use OASIS to identify any affected vehicles in your used vehicle inventory.

**DEALER-OPERATED RENTAL VEHICLES**

The Fixing America's Surface Transportation (FAST) Act law effective June 2016 prohibits a rental company from selling, renting, or leasing vehicles subject to a safety or compliance recall. Please consult your legal counsel for legal advice.

**TITLE BRANDED / SALVAGED VEHICLES**

Affected title-branded and salvaged vehicles are eligible for this recall.

**OWNER REFUNDS**

- **This safety recall must still be performed, even if the owner has paid for a previous repair. Claiming a refund will not close the recall on the vehicle.**
- Ford Motor Company is offering a refund for owner-paid repairs covered by this recall if the repair was performed before the date indicated in the reimbursement plan, which is posted with this bulletin. Owners are directed to seek reimbursement through authorized dealers or, at their option, directly through Ford Motor Company at P.O. Box 6251, Dearborn, MI 48121-6251.
- Dealers are also pre-approved to refund owner-paid emergency repairs that were performed away from an authorized servicing dealer after the end date specified in the reimbursement plan. Non-covered repairs, or those judged by Ford to be excessive, will not be reimbursed.
- Refunds will only be provided for the cost associated with HCU replacement.

**RENTAL VEHICLES**

Rental vehicles are not approved for this program.

**PICK-UP AND DELIVERY**

All customers affected by this program have the option of complimentary Vehicle Pick-up & Delivery service (at participating dealers) in lieu of a rental vehicle. Refer to EFC12071, 2023 Remote Experience Program, Pickup & Delivery (PDL) Offset section for additional details.

**NEW VEHICLE DEMONSTRATION / DELIVERY HOLD - Safety Recall 23S01**  
Certain 2023 Model Year Bronco Sport Vehicles Equipped with a Vacuum Brake Booster  
Anti-Lock Brake (ABS) System Hydraulic Control Unit (HCU) Replacement

**ADDITIONAL REPAIR (LABOR TIME AND/OR PARTS)**

Additional repairs identified as necessary to complete the FSA should be managed as follows:

- For related damage and access time requirements, refer to the Warranty and Policy Manual / Section 6 – Ford & Lincoln Program Policies / General Information & Special Circumstances for FSAs / Related Damage.
- For vehicles within new vehicle bumper-to-bumper warranty coverage, no SSSC approval is required, although related damage must be on a separate repair line with the “Related Damage” radio button checked.
  - Ford vehicles – 3 years or 36,000 miles
- For vehicles outside new vehicle bumper-to-bumper warranty coverage, submit an Approval Request to the SSSC Web Contact Site before completing the repair.

**CLAIMS PREPARATION AND SUBMISSION**

- **Claim Entry:** Enter claims using Dealer Management System (DMS) or One Warranty Solution (OWS) online.
  - When entering claims, select claim type 31: Field Service Action. The FSA number 23S01 is the subcode.
  - For additional claims preparation and submission information, refer to the Recall and Customer Satisfaction Program (CSP) Repairs in the OWS User Guide.
- **Related Damage/Additional labor and/or parts:** Must be claimed as Related Damage on a separate repair line from the FSA with the same claim type and subcode as described in Claim Entry above.

**IMPORTANT:** Click the Related Damage Indicator radio button.
- **Refunds:** Submit refunds on a separate repair line.
  - Program Code: 23S01                      - Misc. Expense: ADMIN
  - Misc. Expense: REFUND                - Misc. Expense: 0.2 Hrs.
  - Multiple refunds should be submitted on one repair line and the invoice details for each repair should be detailed in the comments section of the claim.
- **Pickup & Delivery:** Refer to EFC12071, 2023 Remote Experience Program, Pickup & Delivery (PDL) Offset section for additional details.

**NEW VEHICLE DEMONSTRATION / DELIVERY HOLD - Safety Recall 23S01**  
 Certain 2023 Model Year Bronco Sport Vehicles Equipped with a Vacuum Brake Booster  
 Anti-Lock Brake (ABS) System Hydraulic Control Unit (HCU) Replacement

**LABOR ALLOWANCES**

Description	Labor Operation	Labor Time
Replace the HCU – vehicles with a 1.5L engine	23S01B	1.5 Hours
Replace the HCU – vehicles with a 2.0L engine	23S01C	2.0 Hours

**PARTS REQUIREMENTS / ORDERING INFORMATION**

Part Number	Description	Order Quantity	Claim Quantity
LX6Z-2B373-M	Hydraulic Control Unit	1	1

Order your parts through normal order processing channels. To guarantee the shortest delivery time, an emergency order for parts must be placed.

**DEALER PRICE**

For the latest prices, refer to DOES II.

**PARTS RETENTION, RETURN, & SCRAPPING**

Follow the provisions of the Warranty and Policy Manual, Section 1 - WARRANTY PARTS RETENTION AND RETURN POLICIES. If a replaced part receives a scrap disposition, the part must be scrapped by all applicable local, state, and federal environmental protection and hazardous material regulations. Federal law prohibits selling motor vehicle parts or components that are under safety, compliance, or emissions recall.

**EXCESS STOCK RETURN**

The excess stock returned for credit must have been purchased from Ford Customer Service Division by Policy Procedure Bulletin 4000.

**REPLACED FSA PARTS INSPECTION AND SIGN OFF**

Effective March 1<sup>st</sup>, 2021, all parts replaced as part of an FSA repair with a repair order open date of March 1<sup>st</sup>, 2021, or later must be inspected and signed off on the repair order by a member of your dealer fixed operations management team or an employee of the task has been delegated to. If the task is to be delegated to a non-management employee, the employee needs to be someone other than the technician who completed the repair and needs to understand the importance of completing this task consistently and accurately.

- All parts replaced as part of an FSA repair should be returned to the parts department following the Warranty Parts Retention and Return Policies.
- Inspect the replaced parts to verify the FSA repair was completed.
- If the FSA repair is found to be complete, the designated employee signs the repair order line or parts return stamp area (electronic or hand signed) for the FSA repair indicating the parts were inspected and validated to have been replaced.
- After the parts have been inspected, they should be handled based on the guidance in the parts status report in the Online Warranty System (Hold, Return, CORE, Scrap, etc.).
- This process is subject to review during warranty audits for FSA repairs with a repair order open date of March 1<sup>st</sup>, 2021, or later. Any eligible FSA claims requiring parts replacement found not to have been inspected and signed off during a warranty audit will be subject to chargeback and consideration for enrollment into the Dealer Incomplete Recall Repair Process.

**Note:** Other approvals (electronic or handwritten) for add-on repair lines, dealer-owned vehicle repairs, and repeat repairs do not qualify as FSA parts inspection approvals. The post-repair FSA parts inspection process (electronic or handwritten) is independent of other warranty approval requirements. The approval by the designated employee implies that the FSA parts were found to be replaced and must be able to be identified on the Repair Order. If multiple FSAs require approval on a single Repair Order, each applicable occurrence will require individual post-repair approval by the designated employee.

# CERTAIN 2023 MODEL YEAR BRONCO SPORT VEHICLES EQUIPPED WITH A VACUUM BRAKE BOOSTER — ANTI-LOCK BRAKE (ABS) SYSTEM HYDRAULIC CONTROL UNIT (HCU) REPLACEMENT

## SERVICE PROCEDURE

### Table Of Contents

Vehicles Equipped with a 2.0L Engine.....	1
All Other Vehicles.....	4

### Vehicles Equipped with a 2.0L Engine

1. Remove the front right-hand (RH) side wheel and tire. Please follow Workshop Manual (WSM) procedures in Section 204-04A.
2. Loosen the bolts and remove the undershield. See Figure 1.  
*Torque:*
  - 1: 55 lb.in (6.2 Nm)
  - 2: 177 lb.in (20 Nm)

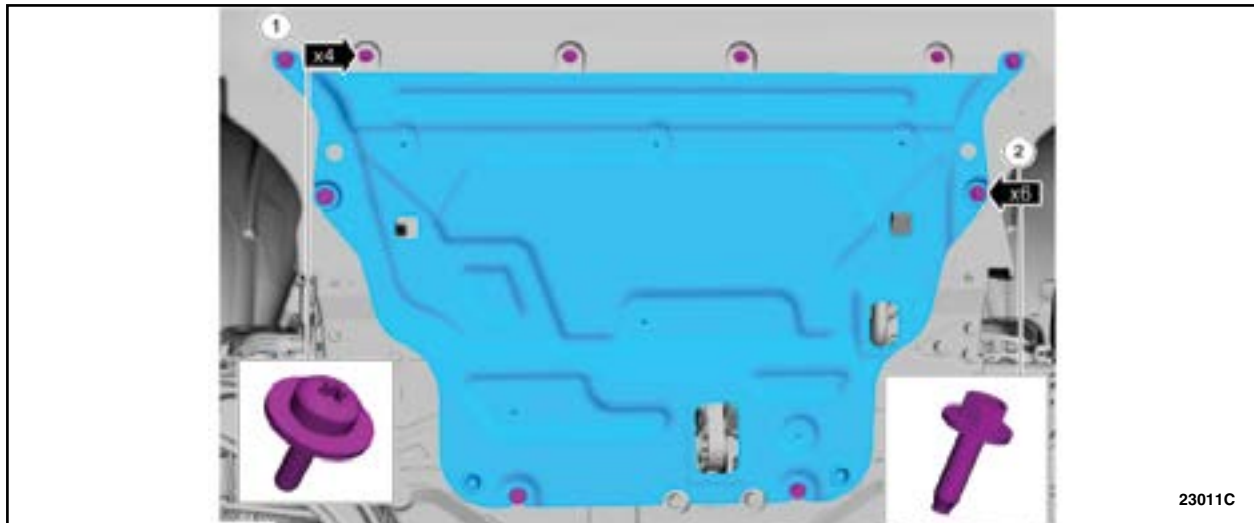
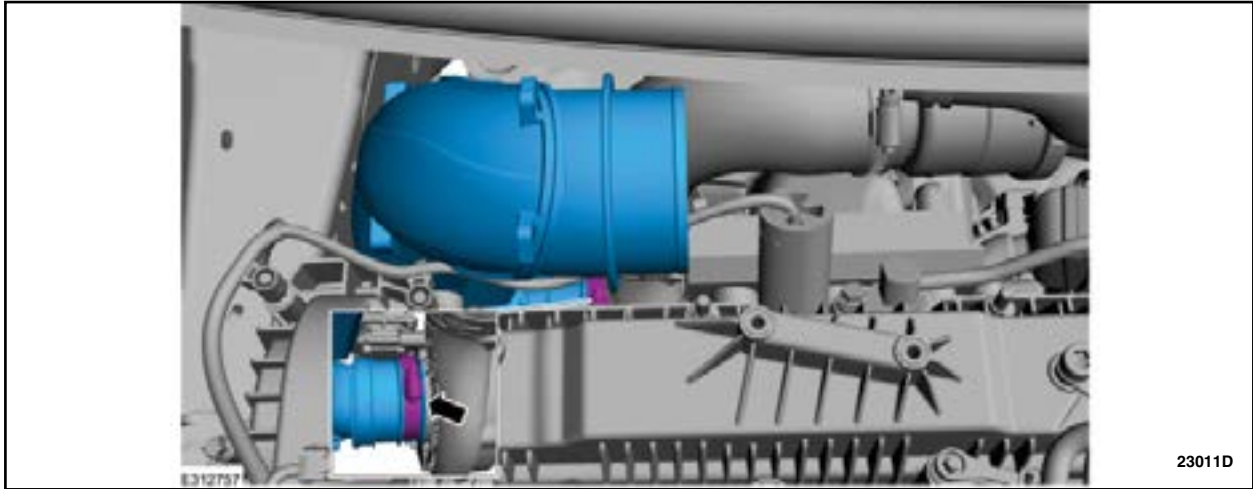

FIGURE 1



3. Loosen the clamp. See Figure 2.
  - *Torque*: 48 lb.in (5.4 Nm)



**FIGURE 2**

4. Lower the vehicle from the hoist to access the engine compartment.
5. Loosen the clamp and remove the charge air cooler (CAC) tube. See Figure 3.
  - *Torque*: 48 lb.in (5.4 Nm)

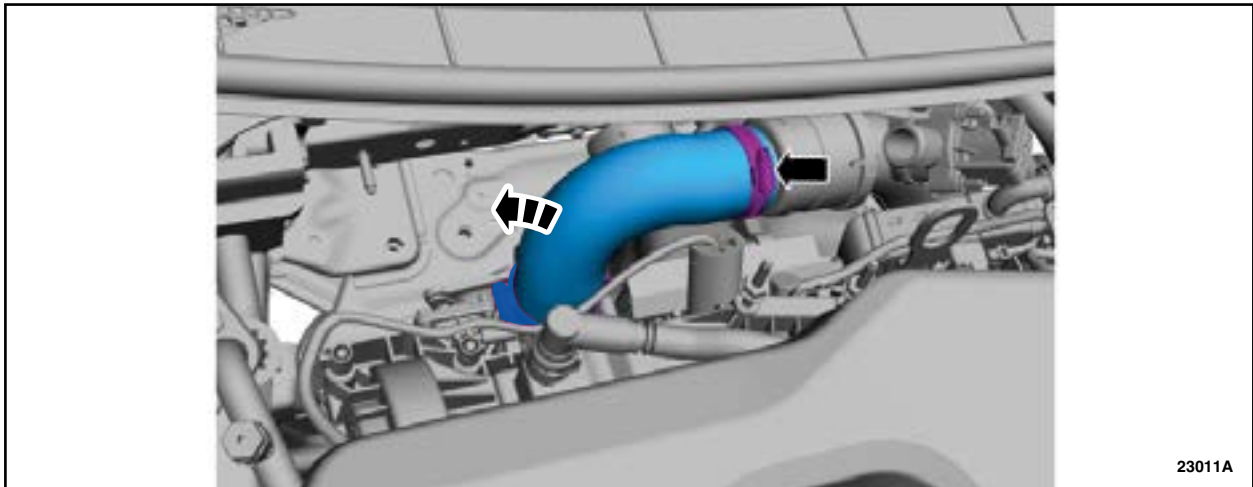

**FIGURE 3**



6. Replace the Hydraulic Control Unit (HCU). Please follow Workshop Manual (WSM) procedures in Section 206-09.

**NOTE:** Before removing the HCU, remove the bolt and position the A/C line bracket aside. See Figure 4.  
• *Torque:* 89 lb.in (10 Nm)



**FIGURE 4**

7. Reassemble the vehicle by reversing steps 1 through 5.



### All Other Vehicles

8. Replace the Hydraulic Control Unit (HCU). Please follow Workshop Manual (WSM) procedures in Section 206-09.

**NOTE:** Before removing the HCU, remove the bolt and position the A/C line bracket aside. See Figure 5.  
• *Torque:* 89 lb.in (10 Nm)



**FIGURE 5**





**Ford Motor Company**  
**Recall Reimbursement Plan for 23S01**

*Ford and Lincoln dealers are in the best position to quickly and efficiently process reimbursement requests. However, federal legislation requires all motor vehicle manufacturers to establish processes through which customers may seek recall reimbursement directly from the manufacturer or the dealers.*

*Regarding the specific reimbursement plan for Recall # 23S01, owners who have paid for service to remedy the defect or noncompliance must have had that service performed before May 12, 2023. After this date, if repairs related to this recall are performed by a non-Ford repair facility in an emergency, customers must submit any refund requests through their dealership. As required by this federal regulation, Ford Motor Company submitted the details of its latest General Recall Reimbursement Plan in a letter to the National Highway Traffic Safety Administration (NHTSA) in May 2021. The following is the text of that letter and the Plan:*

**General Recall Reimbursement Plan**  
(As submitted to the NHTSA)

Under the requirements outlined in 49 CFR Part 573 and Part 577 of the Code of Federal Regulations, Ford Motor Company (Ford) is submitting the required information about our general reimbursement plan for the cost of remedies paid for by vehicle owners before they are notified of a related safety recall.

Set forth below is Ford's general plan to reimburse owners and purchasers for costs incurred for remedies in advance of notification of potential safety-related defects or noncompliance according to Part 573.6 (c)(8)(i). This plan has not changed since our February 20, 2019 submission.

**Reimbursement Notification**

Ford's notice to a vehicle owner in accordance with 49 CFR Part 577 will indicate that Ford is offering a refund if the owner paid to have service to remedy the defect or noncompliance before a specified ending date. In accordance with Part 573.13 (c)(2), this ending date will be defined as a minimum of ten calendar days after the date on which Ford mailed the last of its Part 577 notifications to owners and will be indicated in the specific reimbursement plan available to owners for an individual recall. This notice will direct owners to seek eligible reimbursement through authorized dealers or, at their option, directly through Ford at the following address:

Ford Motor Company  
P.O. Box 6251  
Dearborn, MI 48121-6251

Ford notes that this rule allows for the identification of a beginning date for reimbursement eligibility. Under the rule, an owner who paid to remedy the defect or noncompliance before the identified beginning date would not be eligible for reimbursement. Ford generally has not established such a beginning date for reimbursement eligibility and does not presently anticipate changing this general policy. However, in any case, where Ford determines a beginning date is appropriate, Ford will indicate that date in the owner's notice. As permitted by 577.11(e), Ford may not include a reimbursement notification when all vehicles are well within the warranty period, subject to approval by the agency.

## **Costs to be Reimbursed**

For vehicles, reimbursement will not be less than the lesser of:

- The amount paid by the owner for the remedy that specifically addressed and was reasonably necessary to correct the defect or noncompliance that is the subject of the recall, or
- The cost of parts for the remedy (to be no more than the manufacturer's list retail price for authorized part(s), plus associated labor at local labor rates, miscellaneous fees (such as disposal of waste), and taxes.

For replacement equipment, reimbursement will be the amount paid by the owner for the replacement item (limited by the amount of the retail list price of the defective or noncompliant item that was replaced, plus taxes, where the brand or model purchased by the owner was different from the brand or model that was the subject of the recall). If the item of motor vehicle equipment was repaired, the reimbursement provisions identified above for vehicles will apply.

Ford notes that costs incurred by the owner within the period during which Ford's original or extended warranty would have provided for a free repair of the problem will not be eligible for reimbursement, as provided by Part 573.13 (d)(1).

### Entities Authorized to Provide Reimbursement

Ford will continue to use authorized dealers to reimburse owners under the specific reimbursement plans for a particular recall and will encourage owners to pursue requests for reimbursement directly through dealers to expedite reimbursement. Ford will also provide a mailing address to which customers can, at their option, send requests for reimbursement directly to Ford, as previously noted. Requests for reimbursement sent directly to Ford may take up to 60 days to process. Whether the owner chooses to pursue reimbursement requests through a dealer or directly through Ford, the owner will be directed to submit the required documentation, upon which reimbursement eligibility will be determined.

## **Required Documentation**

The reimbursement determination will depend upon the information provided by the customer. Consistent with Part 573.13 (d)(4) the following information must be submitted:

- Claimant's name and address.
- Vehicle make, model, and model year.
- Vehicle identification number (VIN) and, for replacement equipment, a description of such equipment or, for tires, the model, size, and TIN (DOT code).
- Identification of the recall number (either the Ford recall number or the NHTSA recall number).
- Identification of the owner of the recalled vehicle at the time that the pre-notification remedy was obtained.
- An original receipt for the pre-notification remedy that includes a breakdown of the amount for parts, labor, other costs, and taxes, including costs for the replacement item. Where the receipt covers work other than to address the recall or noncompliance, Ford may require the claimant to separately identify costs that are eligible for reimbursement.
- If the remedy was obtained during the warranty period, documentation indicating that the warranty was not honored or the warranty repair did not correct the problem related to the recall.

Failure to submit all of the above information may result in the denial of the reimbursement request.

**Additional Information**

The Part 577 required owner notice will provide a toll-free telephone number through which specific information about the reimbursement plan can be requested from Ford. This general reimbursement plan will be incorporated into notifications according to Part 573.6 by reference. Information specific to an individual recall also may be incorporated into the Part 573.6 notification.