



PREVOST

**SAFETY
RECALL**

SR22-83

DATE : September 2022	SECTION : 06 ELECTRICAL
SUBJECT: 9700 ALTERNATOR BELT REPLACEMENT	

First Release

INFORMATION REDACTED PURSUANT TO THE FREEDOM OF INFORMATION ACT (FOIA), 5 U.S.C.552(B)(6)

09-27-2022

APPLICATION

NOTICE TO SERVICE CENTERS

*Verify vehicle eligibility by checking warranty bulletin status with **SAP** or via **ONLINE WARRANTY SYSTEM** available on Service / Warranty tab of PrevoSt website.*

Model	VIN
Volvo 9700 Coaches. Model Year: 2020 - 2022	 From 3CET2V92XL5 [REDACTED] up to 3CET2W425N5 [REDACTED] incl. <i>With Remy 55S alternators only</i>

This Safety Recall does not necessarily apply to all the above-mentioned vehicles, some vehicles may have been modified before delivery. The owners of the vehicles affected by this recall will be advised by a letter indicating the Vehicle Identification Number (VIN) of each vehicle concerned.

DESCRIPTION

On vehicles affected by this recall, the heavy duty alternator belt (with aramid cord reinforcement) may continue to turn the alternator pulley after an alternator bearing failure. If the pulley continues to turn, it could lead to front bearing overheat.

Therefore, the heavy duty aramid belt must be replaced by a polyester belt as needed following the interchange table provided.

Before reinstalling the polyester belt, the alternators front bearing must be inspected for damage and the alternator(s) replaced as needed.

Please take note that only the vehicles equipped with a Remy 55S 250 amp alternators are affected by this bulletin.

MATERIAL

PrevoSt Part Number OLD	Belt Type	PrevoSt Part Number NEW	Application
23577315	BELT, POLY V 8PK1410	505611	Volvo 9700

Other parts that may be required:

Part No.	Description	Qty
560720 (Volvo 23507227)	Remy 55S alternator 24V-250A	As req.

NOTE

Material can be obtained through regular channels.

SAFETY PRECAUTIONS

- Eye protection should always be worn when working in a shop.
- Rules for Personal Protection Equipment should always be respected. Wear your PPE including but not limited to the following:



Safety First!



PROCEDURE

 DANGER
<p>Park vehicle safely, apply parking brake, stop the engine. Prior to working on the vehicle, set the ignition switch to the OFF position and trip the main circuit breakers equipped with a trip button. On Commuter type vehicles, set the battery master switch (master cut-out) to the OFF position.</p> <p>Lockout & Tag out (LOTO) must be performed during set-up, maintenance or repair activities. Refer to your local procedure for detailed information regarding the control of hazardous energy.</p>

NOTE

Aramid reinforced cord belt (left) vs new polyester cord belt (right).



Proceed to the belts replacement and bearings inspection following the instruction in the recall video bellow.

NOTE

Prevost vehicles shown in the video. Follow the same basic procedure to inspect an replace parts (as necessary) on the Volvo 9700 coaches

LINK TO THE VIDEO : <https://youtu.be/SnZYD2qYkCw>

Resume of the most common installations.

1. Remove the AC compressor belt.

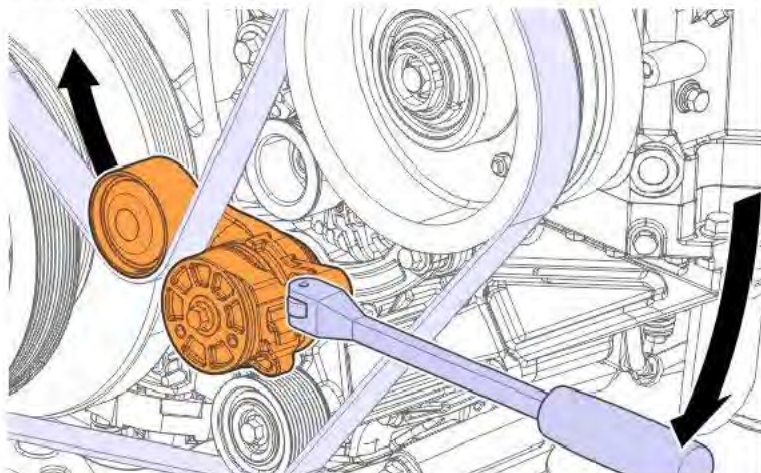

2. Remove the water pump belt.

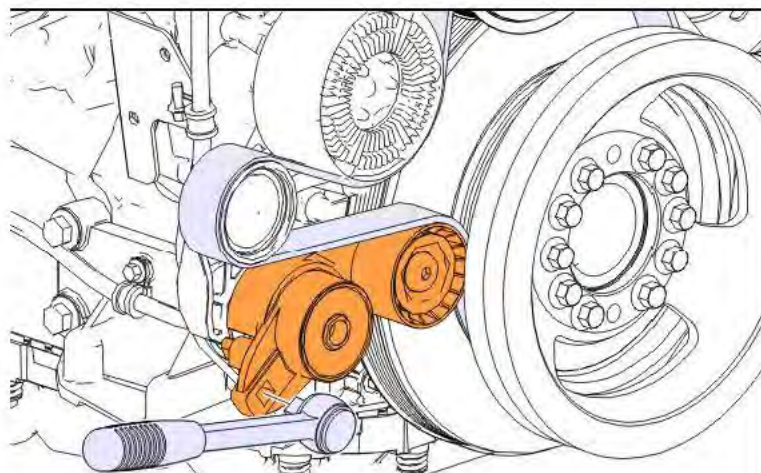

3. Remove the alternator belt.

- Apply torque clockwise to the tensioner (1).
- Insert locking pin (2).

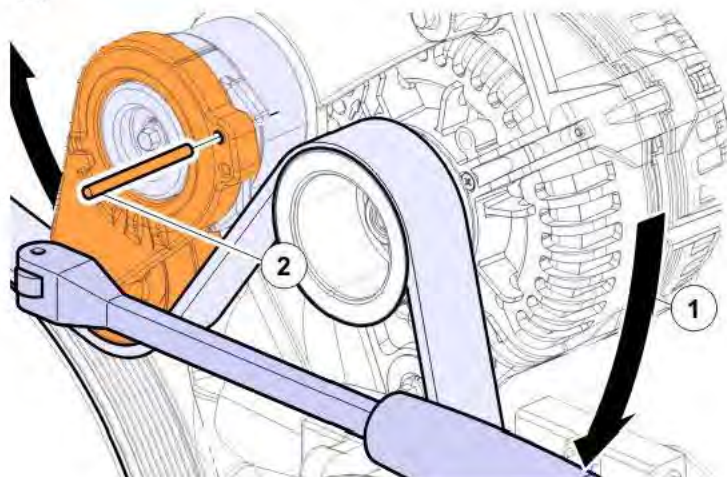

4. Spin all alternators and make sure no bearing noises are coming from the alternator(s). Replace alternator(s) as needed (Only OEM Remy alternator(s) with noisy bearings are covered by this safety recall; See *OEM Remy Alternator Identification* below).

NOTE

As a good practice, spin all idlers and tensioners and make sure no bearing noises are heard and replace the bearing(s) as required (idler & tensioner *are not part* of this safety recall unless covered by std vehicle warranty – Std warranty process must be used to claim these parts).

5. Reverse the procedure to reinstall the belts on the vehicle.

OEM REMY ALTERNATOR IDENTIFICATION

REMY 55S 250AMP

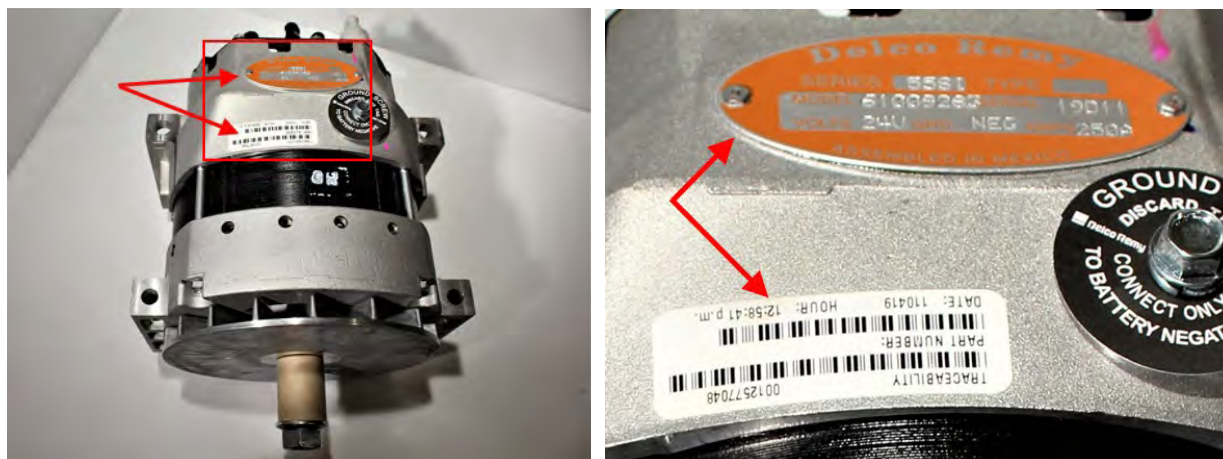

- REMY 55S Alternator will have a Delco-Remy identification plate riveted to the body as well as a bar code sticker next to the ground stud as shown.

PARTS DISPOSITION

All replaced parts must be returned to PrevoSt according to the Return Shipping Instructions available on www.prevoStcar.com (under service / warranty section) for full reimbursement. A copy of the warranty claim form must be enclosed with the shipment.

WARRANTY

This modification is covered by PrevoSt's normal warranty. We will reimburse you the belts and 3/4 hour (0.75) of labor for the inspection and belt replacement upon receipt of a completed A.F.A.

We will also reimburse you the parts and two hour(s) (2.0) of labor for each defective OEM alternator.

Please submit claim via our Online Warranty System, available at www.prevoStcar.com (under service \ warranty section). Use Claim Type: "Bulletin/Recall" and select "Safety Recall SR22-83".

Should you only wish to close the safety recall (without reimbursement), fill-in the "Safety Recall Certification Sheet" provided with this bulletin and return it to our warranty department by Email at prevost.warranty@volvo.com.

OTHER

VBC Bulletin	N/A
Fail Code	06.01
Defect Code	09
Syst.Cond	R
Causal Part	23577315

Access all our Service Bulletins on <http://techpub.prevostcar.com/en/> or scan the QR-Code with your smart phone.
E-mail us at **technicalpublications_prev@volvo.com** and type "ADD" in the subject to receive our warranty bulletins by e-mail.





**Safety Recall
Certification Sheet
(Ref: SR22-83)**

VEHICLE SERIAL NUMBER:

--	--	--	--	--	--	--	--	--	--	--	--	--	--	--	--	--	--	--	--	--

PERFORMED BY		OWNER/OPERATOR	
We hereby certify that Safety Recall Instructions with regard to Safety Recall SR22-83 have been performed.			
Name: _____		Name: _____	
Addr: _____		Addr: _____	
Phone: _____		Phone: _____	
Fax: _____		Fax: _____	
Signature : _____		Signature : _____	
Date: _____		Date: _____	

If the information mentioned above is incorrect or you are not the owner of this vehicle anymore, please fill this section and return to sender.

NEW OWNER:

BUSINESS:

ADDRESS (including County):

TELEPHONE: _____

FAX: _____

Please return this completed document with your A.F.A. form