



R22CB

SECOND FINAL NOTICE

DATE: January 11, 2024
TO: Blue Bird Owners
Subject: R22CB: 7.3L Gas Supply Line And Shifter Cable Interference

According to our records, we have not received confirmation the above referenced recall, dated February 13, 2023, has been completed. A copy of Recall R22CB is attached. Your buses affected by Recall R22CB are identified by Blue Bird body number and VIN under Section 2 on the enclosed cover sheet.

If this is the first time you received notification of Recall R22CB, please read the enclosed notification carefully. Recall R22CB must be completed, as soon as possible.

Corrective Action:

To correct this condition, affected vehicles will need to be inspected and repaired, per R22CB Recall Instructions. The shift cable will need to be inspected and/or properly routed. The affected units will need to be inspected for this condition and possibly rerouted if any signs of a wear are observed. Blue Bird will reimburse the labor cost of the repair related to this recall at no cost to the vehicle owner. Please contact your local Blue Bird dealer to arrange to have the Recall performed. To locate an authorized dealer, search online at www.blue-bird.com/find-a-dealer Parts to complete Recall R22CB are currently available. You may request parts through campaignparts@blue-bird.com

Labor Reimbursement:

Blue Bird will reimburse the labor cost of the repairs related to this recall at no cost to you the vehicle owner. The standard repair time (SRT) to accomplish these repairs in accordance with the R22CB remedy procedure(s) is outlined below. The remedy would be comprised of Repair A, or Repair A in combination with Repair B, Repair C and/or Repair D based on the inspection findings.

Repair A: Inspection Only: 0.2 Hours (12 minutes)
Repair B: Re-routing Shift Cable: 0.3 Hours (18 minutes)
Repair C: Install Brackets: 0.3 Hours (18 minutes)
Repair D: Fuel Line Replacement: 0.7 Hours (42 minutes)

Thank you for your prompt attention to this matter.



R22CB

IMPORTANT SAFETY RECALL NOTICE

NHTSA Recall Number: 22V-739 School Bus
NHTSA Recall Number: 22V-740 Non-School Bus

DATE: February 13, 2023

SUBJECT: R22CB: 7.3L Gas Supply Line And Shifter Cable Interference

Dear Blue Bird Owner:

This notice applies to your bus(es) identified by both Blue Bird Body Number and Vehicle Identification Number (VIN) on the enclosed yellow cover sheet. If you no longer own the subject bus(es), please complete the appropriate section of the yellow cover sheet and return to Blue Bird in the enclosed pink postage prepaid envelope.

This notice is sent to you in accordance with the requirements of the National Traffic and Motor Vehicle Safety Act.

Blue Bird Body Company has decided that a defect which relates to motor vehicle safety exists in:

- Certain model year 2022 through 2023 Blue Bird Vision School Buses
 - manufactured from May 3, 2021 through June 16, 2022
- Certain model year 2022 through 2023 Blue Bird Vision Non-School Buses
 - manufactured from June 11, 2021 through February 25, 2022

On the subject buses, it has been determined that certain Blue Bird Vision (BBCV) School and Non-School Buses equipped with 7.3L gasoline powered engines have a potential for the transmission shift cable to have insufficient clearance to the gasoline fuel supply line at the left rear corner of the engine. The transmission shift cable may come in physical contact with the gasoline fuel line at the rear of the engine. This inadvertent contact could abrade the gasoline fuel line and cause potential leaks. Additionally, some units may be missing the heat shield bracket, which is used to secure the shift cable. Potential interference could cause leak(s) of pressurized gasoline within the approximate area of the hot surfaces of the engine and could increase risk of a fire.

Corrective Action:

To correct this condition, affected vehicles will need to be inspected and repaired, per R22CB Recall Instructions. The shift cable will need to be inspected and/or properly routed. The affected units will need to be inspected for this condition and possibly rerouted if any signs of a wear are observed. Blue Bird will reimburse the labor cost of the repair related to this recall at no cost to the vehicle owner. Please contact your local Blue Bird dealer to arrange to have the Recall performed. To locate an authorized dealer, search online at www.blue-bird.com/find-a-dealer You may request parts at campaignparts@blue-bird.com **Parts are currently available.**

Labor Reimbursement:

Blue Bird will reimburse the labor cost of the repairs related to this recall at no cost to you the vehicle owner. The standard repair time (SRT) to accomplish these repairs in accordance with the R22CB remedy procedure(s) is outlined below. The remedy would be comprised of Repair A, or Repair A in combination with Repair B, Repair C and/or Repair D based on the inspection findings.



BLUE BIRD

Blue Bird Body Company

Page 2

R22CB

Labor Reimbursement: (continued)

Repair A: Inspection Only: 0.2 Hours (12 minutes)

Repair B: Re-routing Shift Cable: 0.3 Hours (18 minutes)

Repair C: Install Brackets: 0.3 Hours (18 minutes)

Repair D: Fuel Line Replacement: 0.7 Hours (42 minutes)

Administering the Recall and Parts:

Parts to complete Recall R22CB are currently available. You may request parts through campaignparts@blue-bird.com

Federal law requires that any vehicle lessor receiving this recall notice must forward a copy of this notice to the lessee within ten days.

If the modifications directed by this notification were performed on your bus prior to the receipt of this recall notification, attach a copy of the work order/invoice. Mail the documents in the pink self-addressed postage prepaid envelope included with the pink reply sheet to Blue Bird for warranty consideration. Reimbursements will be made in accordance with the requirements of the National Highway Transportation Safety Act, Title 49 Code of Federal Regulations, Parts 573 and 577.

Please contact your local Blue Bird Dealer with any questions regarding this recall campaign.

If Blue Bird Body Company should fail to or is unable to remedy this condition without charge to you, you may contact:

**ADMINISTRATOR
NATIONAL HIGHWAY TRAFFIC SAFETY ADMINISTRATION
1200 NEW JERSEY AVENUE, SE
WASHINGTON, D.C. 20590**

Or, you may call The National Highway Traffic Safety Administration toll free at:
1-888-327-4236 TTY 1-800-424-9153 or go to: <http://www.safercar.gov>



RECALL R22CB

7.3L SHIFT CABLE-GASOLINE FUEL LINE INTERFERENCE

Models Affected: Certain 2022 & 2023 Model Year Blue Bird Vision Buses equipped with 7.3L Gasoline engine

Issue: In certain vehicles, the transmission shift cable may come in physical contact with the gasoline fuel line at the rear of the engine. This inadvertent contact could abrade the gasoline fuel line and cause potential leaks. Additionally, some units may be missing the heat shield bracket, which is used to secure the shift cable.

Corrective Action: Inspect and if action is needed, re-route & secure the transmission shift cable away from the fuel line, per the below instructions. Replace damaged or missing components, as needed.

WARNING: Always follow all Federal, State, Local and Shop safety standards and use proper safety equipment, and thoroughly read and understand all instructions before performing these procedures. Park bus on level surface, apply parking brake, turn off ignition key, and chock wheels.

Related Tools:

Description	Tool Number
Fuel line disconnect tool	Rotunda 310-250 or equivalent
Hand tools	
Side cutters	

Service Parts:

Item	Description	Part Number	Quantity
1	TIE,CABLE,NYLON,BUTTON HD,14.75L X .22W	00024076	1
2	BRACKET,HEAT SHIELD,HYD BRAKE,FORD CV	10062357	1
3	BRACKET,STEEL,MNT,HYD BRAKE	10068143	1
4	NUT,HEX HD,5/16-18,SER WASHER,YEL ZN DICH	00829390	2
5	WASHER,FLAT,5/16 X 3/4 X 5/64,YEL ZN DICH	10029717	2
6	CAPSCREW,HEX HD,5/16-18X7/8,GR8,YEL ZN DICH	00854414	2
7	FUEL LINE,GAS,SUPPLY,SECTION 1	10070231	1

Labor Operations:

Repair	Description	Labor Hours	Parts Needed
A	Inspection	0.2 Hours (12 minutes)	No Parts
B	Re-routing Shift Cable	0.3 Hours (18 minutes)	Item 1
C	Install Brackets	0.3 Hours (18 minutes)	Items 1 - 6
D	Fuel Line Replacement	0.7 Hours (42 minutes)	Items 1 - 7

Instructions:

Step 1: Inspect the left rear corner of the engine from the top, and the bottom. If there is greater than 3” of clearance between the shift cable and the fuel line, no further action is required. Ref. Figure 1 for an example of insufficient clearance. If <3” of clearance, proceed to step 2.

CAUTION: DO NOT STEP ON THE ENGINE



BLUE BIRD

RECALL R22CB

7.3L SHIFT CABLE-GASOLINE FUEL LINE INTERFERENCE

Step 2: If vehicle is equipped with an air system, ensure shift cable is routed on the toe-box side of the air bundle. If not routed properly, shift to neutral & secure the chassis. Remove shift cable from transmission bracket and shift arm.

CAUTION: For vehicles with transmission park position feature; double check parking brake is set & wheels are chocked prior to shifting to neutral and removing shift cable.

Step 3: Verify the heat shield bracket (Item 2), regardless of brake type is in place. Reference Figure 2. If missing, install per Figure 3.

Step 4: Verify shift cable is routed properly and secured to the bracket with the HD button cable tie, p/n 00024076 per Figure 3

Step 5: With transmission in neutral, and shifter in neutral, make needed adjustments to the cable trunnion that allows smooth engagement into the transmission shifter arm.

Step 6: Carefully inspect the gasoline fuel line. **Any** physical damage to the fuel line requires replacement.

Step 7: If fuel line replacement is necessary, follow the below steps-

A- Remove the fuel system fuse. Fuse FH16(NEA), or fuse FB1-2(non-NEA).

B- Start the engine and allow it to stall. Attempt to start again until the engine no longer starts.

C- Disconnect the battery negative terminal.

a. **NOTE:** Even if equipped with a battery disconnect, **remove battery negative terminal.**

D- Wearing appropriate PPE, lay an absorbent cloth below the fuel line connection at the fuel rail and slowly disconnect the fuel line using Rotunda 310-250 or equivalent. See Figure 4

a. **NOTICE:** When reusing liquid or vapor tube connectors, make sure to use compressed air to remove any foreign material from the connector retaining clip area before separating from the tube or damage to the tube or connector retaining clip can occur. Apply clean engine oil to the end of the tube before inserting the tube into the connector.

b. **NOTICE:** Fuel injection equipment is manufactured to very precise tolerances and fine clearances. It is essential that absolute cleanliness is observed when working with these components or component damage can occur. Always install plugs to any open orifices or tubes.

E- Replace fuel line. Discard fuel laden cloth appropriately.

F- Re-connect negative battery terminal and torque to 44-72 in-lbs.

G- Install the fuel system fuse. The fuel pump should run for ~3 seconds. Check the system for leaks. If none found, start the engine. Verify no leaks are present.

Step 8: Connect IDS or RDT and reset fault codes.

Step 9: Open datalogger and monitor TR_DC%. Verify value reports between 40-46% in Neutral. Make necessary shift cable adjustments if out of specification.

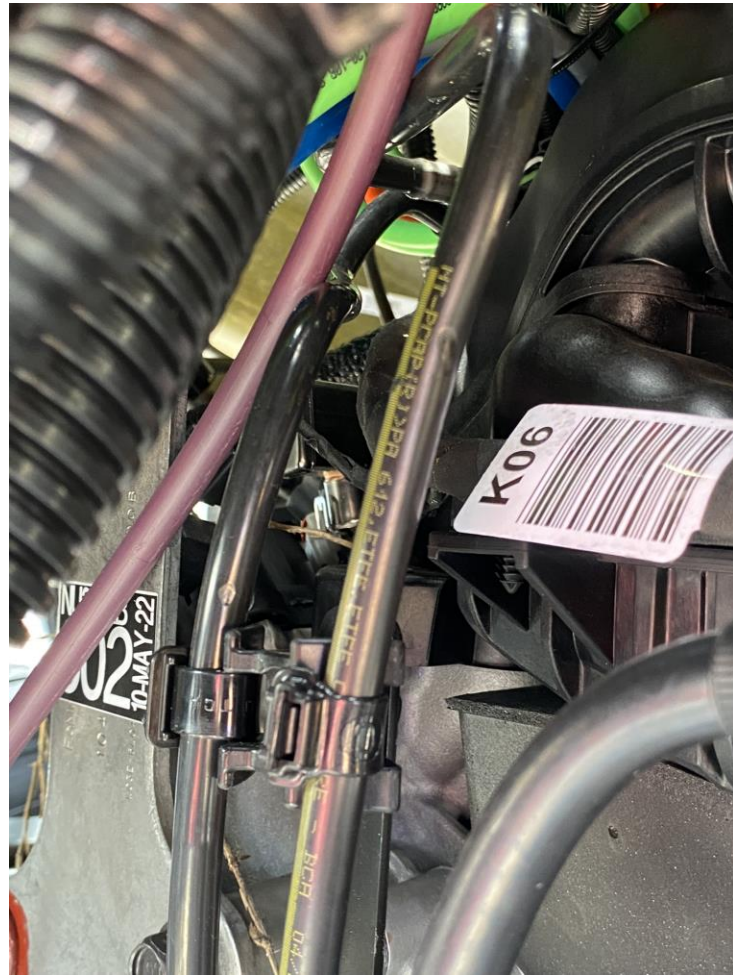

Fig 1

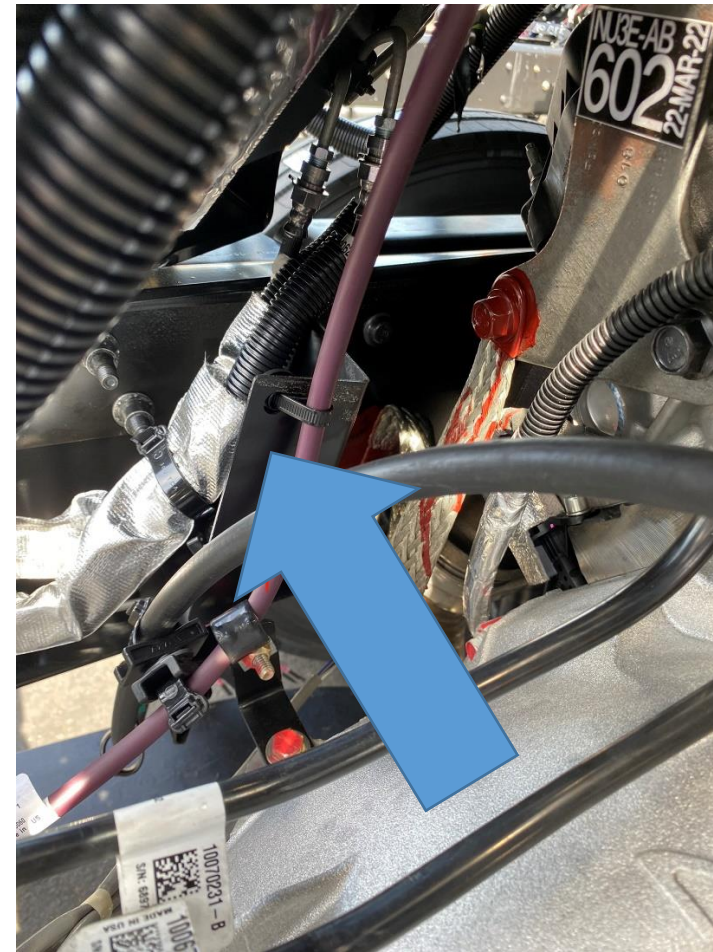

Fig 2



BLUE BIRD

RECALL R22CB

7.3L SHIFT CABLE-GASOLINE FUEL LINE INTERFERENCE

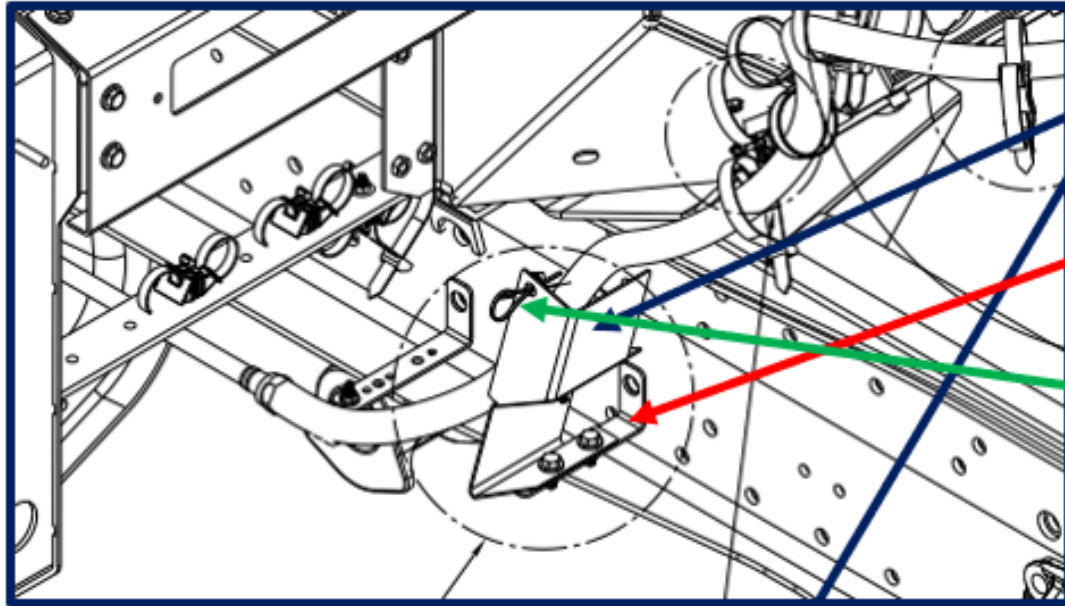

10062357

10068143

00024076

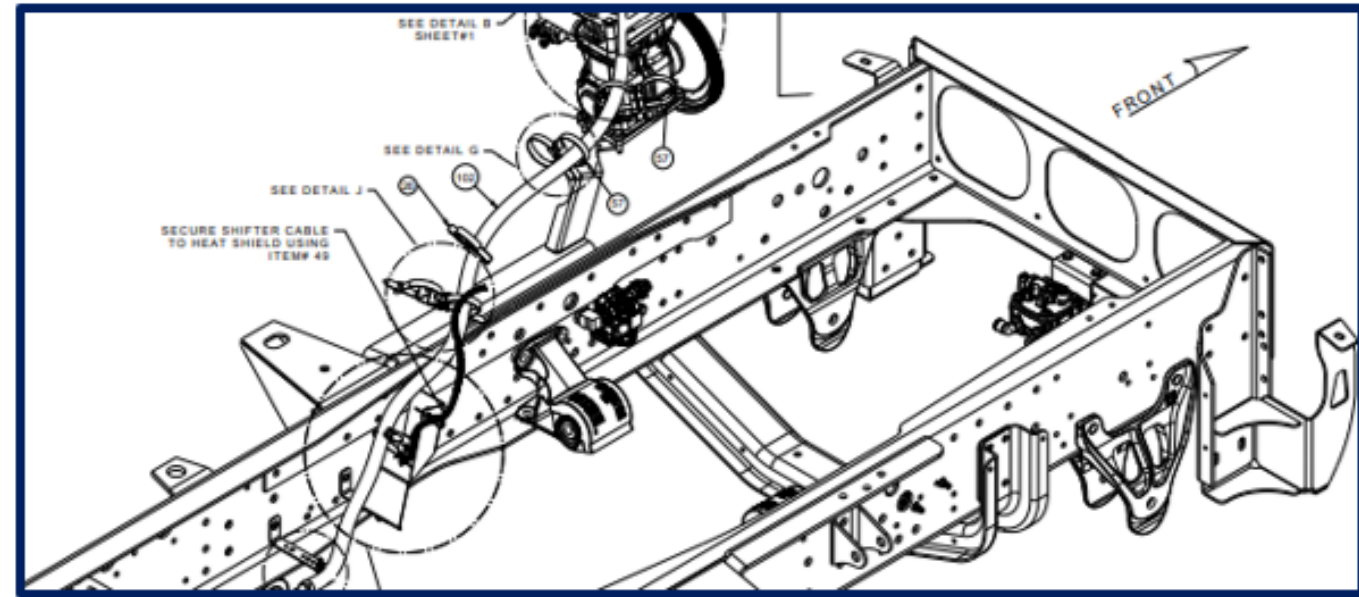
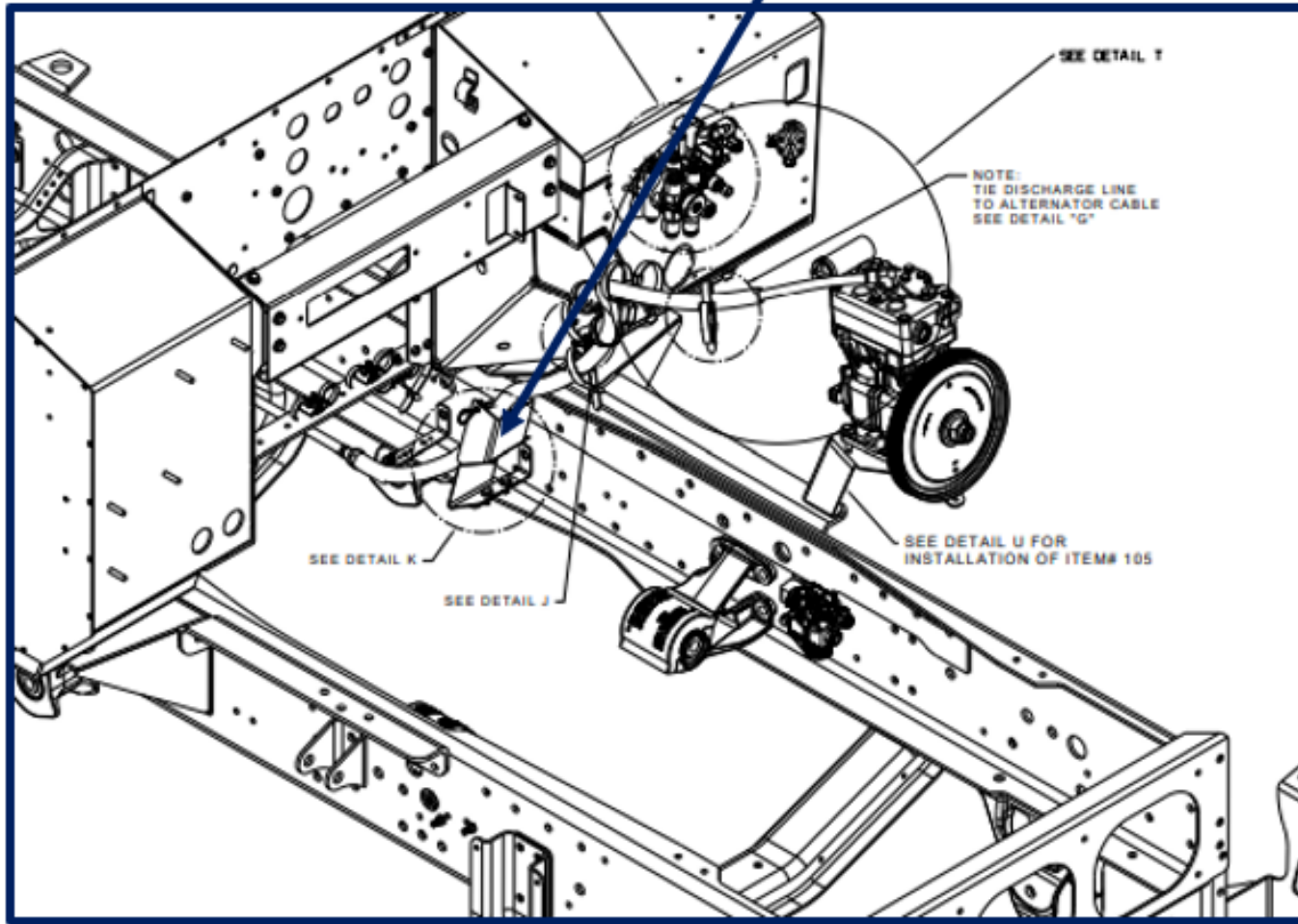
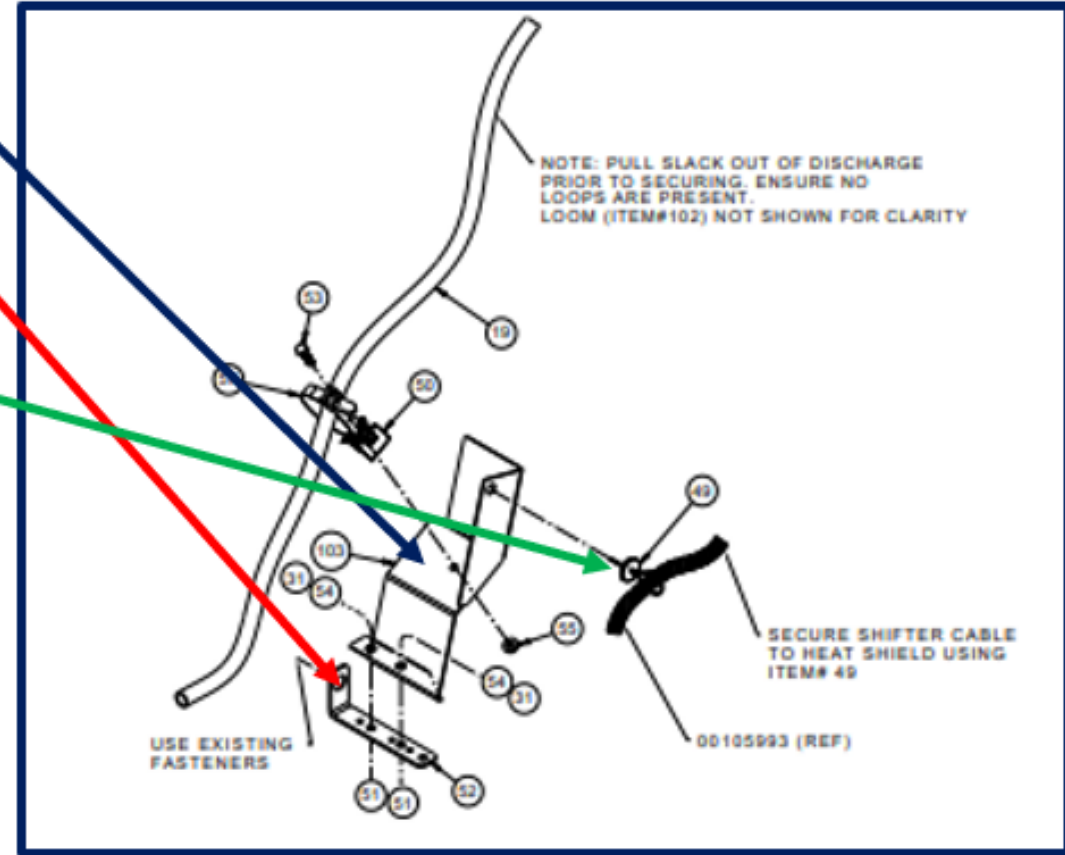

Fig 3

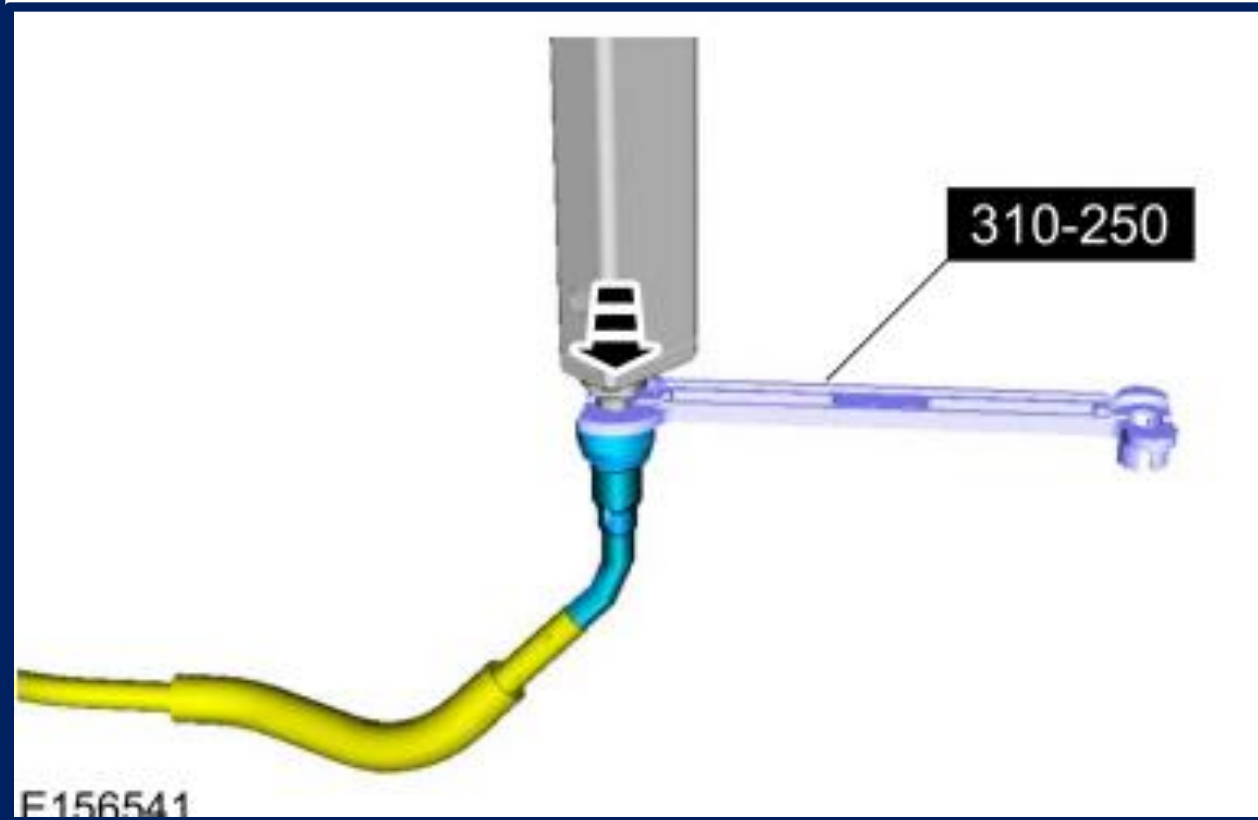
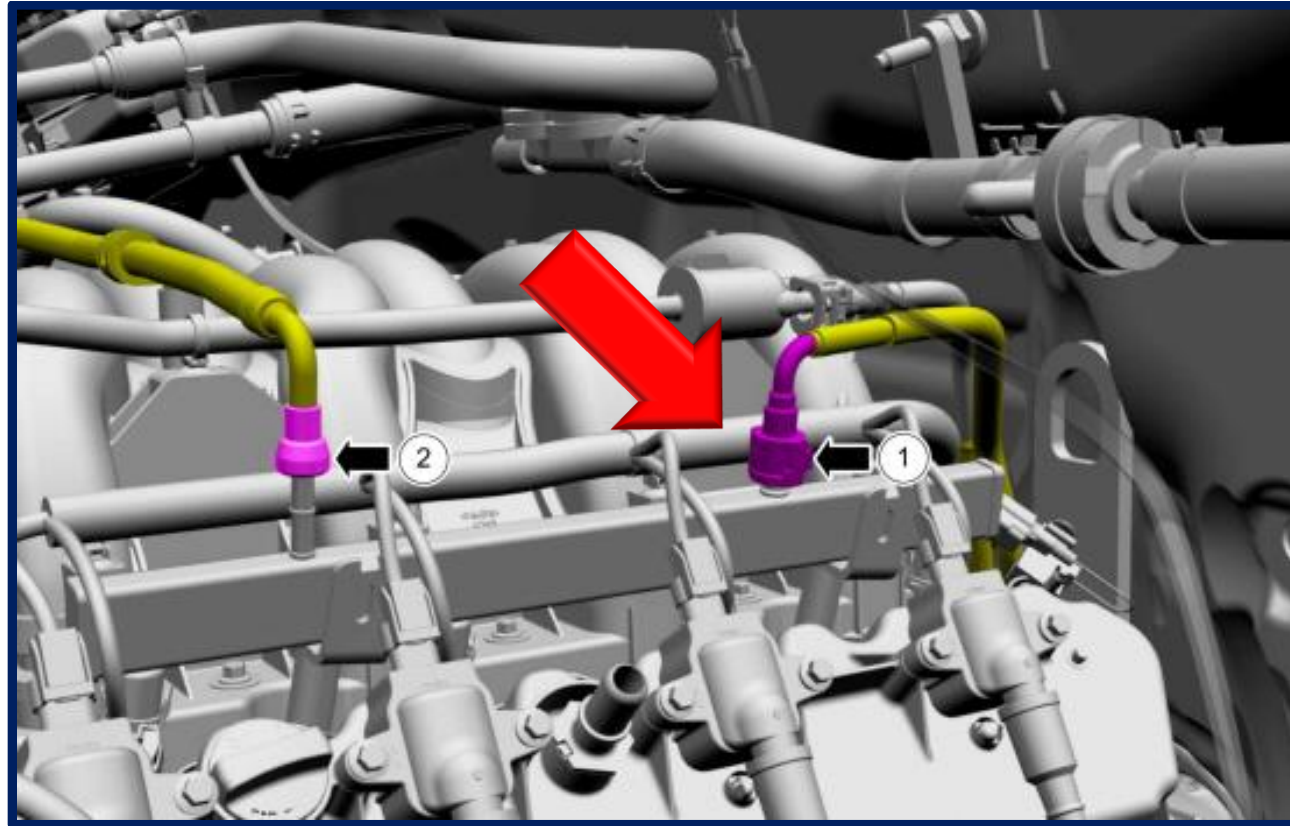

Fig 4