



R22CA

**SECOND FINAL NOTICE**

**DATE:** September 7, 2023  
**TO:** Blue Bird Owners  
**Subject:** R22CA: LPG Supply Line & RH Park Brake Cable Interference on Ford 6.8L

According to our records, we have not received confirmation that the above referenced recall, dated November 18, 2022, has been completed. A copy of Recall R22CA is attached. Your buses affected by Recall R22CA are identified by Blue Bird body number and VIN under Section 2 on the enclosed cover sheet.

If this is the first time you received notification of Recall R22CA, please read the enclosed notification carefully. Recall R22CA must be completed, as soon as possible.

**Corrective Action:**

To correct this condition, affected vehicles will need to be inspected and repaired, per R22CA Recall Instructions. The fuel lines and park brake cable will need to be properly routed and secured. The affected units will need to be inspected for this condition and either secured, re-secured, or repaired if any signs of a wear are observed. Blue Bird will reimburse the labor cost of the repair related to this recall at no cost to the vehicle owner. Please contact your local Blue Bird dealer to arrange to have the Recall performed. To locate an authorized dealer, search online at [www.blue-bird.com/find-a-dealer](http://www.blue-bird.com/find-a-dealer) You may request parts at [campaignparts@blue-bird.com](mailto:campaignparts@blue-bird.com) **Parts are currently available.**

**Labor Reimbursement:**

Blue Bird will reimburse the labor cost of the repairs related to this recall at no cost to you the vehicle owner. The standard repair time (SRT) to accomplish these repairs in accordance with the R22CA remedy procedure(s) is outlined below.

**Repair Options and allowable labor times for this campaign, outlined as follows:**

**Repair A: Inspection Only**

- 0.2 Hours (12 minutes)

**Repair B: Inspection and Re-secure PB Cable**

- 0.4 Hours (24 minutes)

**Repair C: Inspection, Re-securing PB Cable, and Replacement of Fuel Line**

- 1.5 Hours (90 minutes)

Thank you for your prompt attention to this matter.



R22CA

**IMPORTANT SAFETY RECALL NOTICE**

**NHTSA Recall Number: 22V-736 School Bus**

**DATE: November 18, 2022**

**SUBJECT: R22CA: LPG Supply Line & RH Park Brake Cable Interference on Ford 6.8L**

**Dear Blue Bird Owner:**

This notice applies to your bus(es) identified by both Blue Bird Body Number and Vehicle Identification Number (VIN) on the enclosed yellow cover sheet.

This notice is sent to you in accordance with the requirements of the National Traffic and Motor Vehicle Safety Act.

Blue Bird Body Company has decided that a defect which relates to motor vehicle safety exists in certain:

- Model year 2013 through 2021 Blue Bird Vision School Buses
  - manufactured from January 24, 2012 through December 11, 2019

The LPG supply line may be damaged from contact with the right-hand park brake cable, which can result in a fuel leak. There is no advanced warning of the condition without inspection of the fuel line. Therefore, the fuel line should be inspected for signs of contact and wear before using the bus. If the fuel line leaks, it could increase the risk of a fire in the presence of an ignition source.

**Corrective Action:**

To correct this condition, affected vehicles will need to be inspected and repaired, per R22CA Recall Instructions. The fuel lines and park brake cable will need to be properly routed and secured. The affected units will need to be inspected for this condition and either secured, re-secured, or repaired if any signs of a wear are observed. Blue Bird will reimburse the labor cost of the repair related to this recall at no cost to the vehicle owner. Please contact your local Blue Bird dealer to arrange to have the Recall performed. To locate an authorized dealer, search online at [www.blue-bird.com/find-a-dealer](http://www.blue-bird.com/find-a-dealer). You may request parts at [campaignparts@blue-bird.com](mailto:campaignparts@blue-bird.com). **Parts will be available on or before December 21, 2022.**

**Labor Reimbursement:**

Blue Bird will reimburse the labor cost of the repairs related to this recall at no cost to you the vehicle owner. The standard repair time (SRT) to accomplish these repairs in accordance with the R22CA remedy procedure(s) is outlined below.

**Repair Options and allowable labor times for this campaign, outlined as follows:**

**Repair A: Inspection Only**

- 0.2 Hours (12 minutes)

**Repair B: Inspection and Re-secure PB Cable**

- 0.4 Hours (24 minutes)

**Repair C: Inspection, Re-securing PB cable, and Replacement of Fuel Line**

- 1.5 Hours (90 minutes)



**BLUE BIRD**

Blue Bird Body Company

Page 2

R22CA

**Administering the Recall and Parts:**

Parts to complete Recall R22CA will be available on or before **December 21, 2022**. You may request parts through [campaignparts@blue-bird.com](mailto:campaignparts@blue-bird.com)

**Federal law requires that any vehicle lessor receiving this recall notice must forward a copy of this notice to the lessee within ten days.**

If you no longer own the subject bus(es), please complete the appropriate section of the yellow cover sheet and return to Blue Bird in the enclosed pink postage prepaid envelope.

**If the modifications directed by this notification were performed on your bus prior to the receipt of this recall notification, attach a copy of the work order/invoice.** Mail the documents in the pink self-addressed postage prepaid envelope included with the pink reply sheet to Blue Bird for warranty consideration. Reimbursements will be made in accordance with the requirements of the National Highway Transportation Safety Act, Title 49 Code of Federal Regulations, Parts 573 and 577.

**Please contact your local Blue Bird Dealer with any questions regarding this recall campaign.**

If Blue Bird Body Company should fail to or is unable to remedy this condition without charge to you, you may contact:

**ADMINISTRATOR  
NATIONAL HIGHWAY TRAFFIC SAFETY ADMINISTRATION  
1200 NEW JERSEY AVENUE, SE  
WASHINGTON, D.C. 20590**

Or, you may call The National Highway Traffic Safety Administration toll free at:  
1-888-327-4236 TTY 1-800-424-9153 or go to: <http://www.safercar.gov>



# RECALL R22CA

## LPG Supply Line & RH Park Brake Cable Interference

**Models Affected:** Certain 2013-2021 Model Year Blue Bird Vision Buses equipped with 6.8L Propane engine and RH hand lever parking brake

**Issue:** RH mounted park brake lever cable may not be secured and/or routed properly. In certain cases, the park brake cable may lay on the propane fuel lines causing damage. Additionally, an improperly secured RH park brake cable may damage/dislodge the automatic transmission vent which could allow water/dust/debris to enter transmission assembly and cause subsequent damage.

**Corrective Action:** Inspect unit for proper RH park brake cable routing and securement. If routed and secured per D0007365, no additional action is required. If routing and securement is not per D0007365, re-route and/or re-secure per D0007365.

**WARNING:** Always follow all Federal, State, Local and Shop safety standards and use proper safety equipment, and thoroughly read and understand all instructions before performing these procedures. Park bus on level surface, apply parking brake, turn off ignition key, and chock wheels.

Related service parts:

Item	Description	Part Number	Quantity
1	Mount, Heavy Duty, .250-hole size	00024168	As needed, max 2/bus
2	CAPSCREW,HEX HD,1/4-20 X 1,GR 5,YEL ZN DICH	00870477	As needed, max 2/bus
3	NUT,HEX,FLANGE SER,1/4-20,BLACK ZINC	00659979	As needed, max 2/bus
4	WASHER,FLAT,17/64 ID X 5/8,YEL ZN DICH	01247709	As needed, max 2/bus
5	TIE,CABLE,250LB	00029998	As needed, max 2/bus
6	TUBE,VENT,TRANSMISSION,FORD	10056558	As needed, 1 per bus
7	PIPE ASSY,PROPANE,FRWD FUEL LINE,SUPPLY,MY16,CV	10044217	As needed, 1 per bus
8	HOSE ASSY,PROPANE,FRWD FUEL LINE FEED,ROUSH,CV	10022860	As needed, 1 per bus
9	HOSE ASSY,PROPANE,FRWD FUEL LINE RETURN,ROUSH,CV	10022862	As needed, 1 per bus

**NOTE:** If either fuel line is damaged on GEN4 fuel systems (post 2016), order and install Fuel Line Assy (item #7) listed above. If a replacement line is needed for GEN 3 vehicles, they are serviced separately (items #8 and #9) listed above.

### Instructions:

- Step 1:** Inspect suspect area and verify park brake cable is secure. Ensure cable tie mounts are in place & torqued properly to the chassis routing bracket at 76 in-lbs.
- Step 2:** Replace and/or re-torque HD cable tie mounts, as necessary.
- Step 3:** Ensure transmission vent is in place. Replace if necessary.
- Step 4:** Inspect Liquid Propane fuel lines for any damage and replace, as needed.



# RECALL R22CA

## LPG Supply Line & RH Park Brake Cable Interference

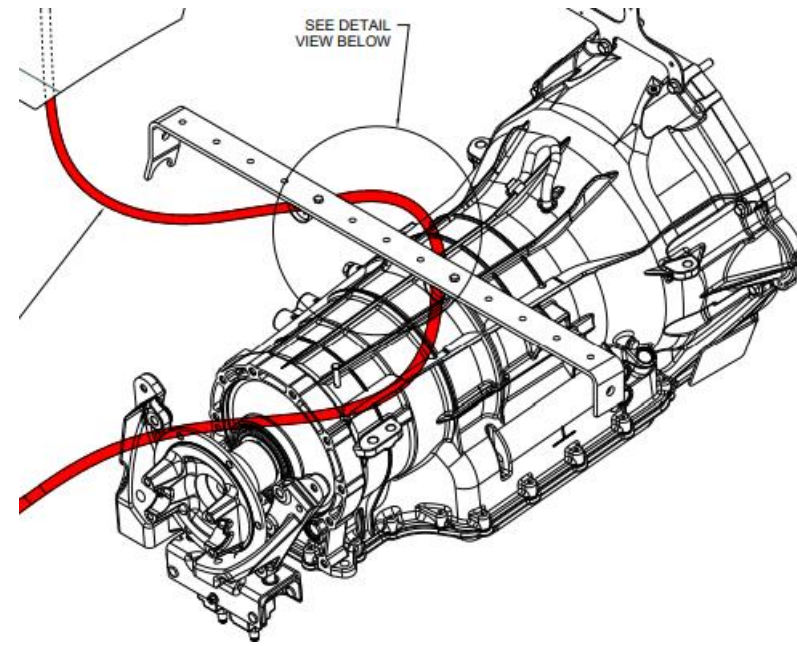
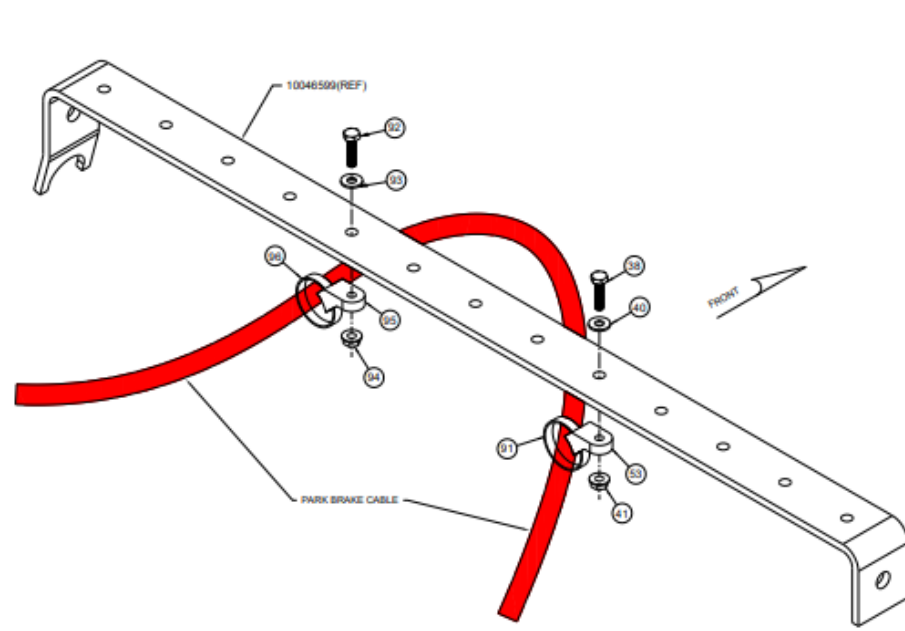



REVISION	Y	DATE	BY	APP	DESCRIPTION	
DR	TTL	APP	BH	B14261	REDAWN IN 3D; DELETED PICTURES FROM SHEET 3; UPDATED NOTE 1 ON SHEET 4; REMOVED ITEM 81 AS ADDED OPTIONAL PART AND UPDATED REMARKS FOR ITEM 29 PER TORQ 110209	
REVISION	Z	3/10/2022	WAS		REMOVED BRACKET 1004865 FROM ALL VIEWS, BUT REPLACED IT WITH 10070232 IN DETAIL D	
DR	AJ	APP	AJ	B15270	00971732	REMOVED BRACKET 1004865 FROM ALL VIEWS, BUT REPLACED IT WITH 10070232 IN DETAIL D
REVISION	AA	3/10/2022	WAS		W/ GAS, REPLACED ITEM #47.	
DR	TTL	APP	SM	B15022		SEE SHEET #3

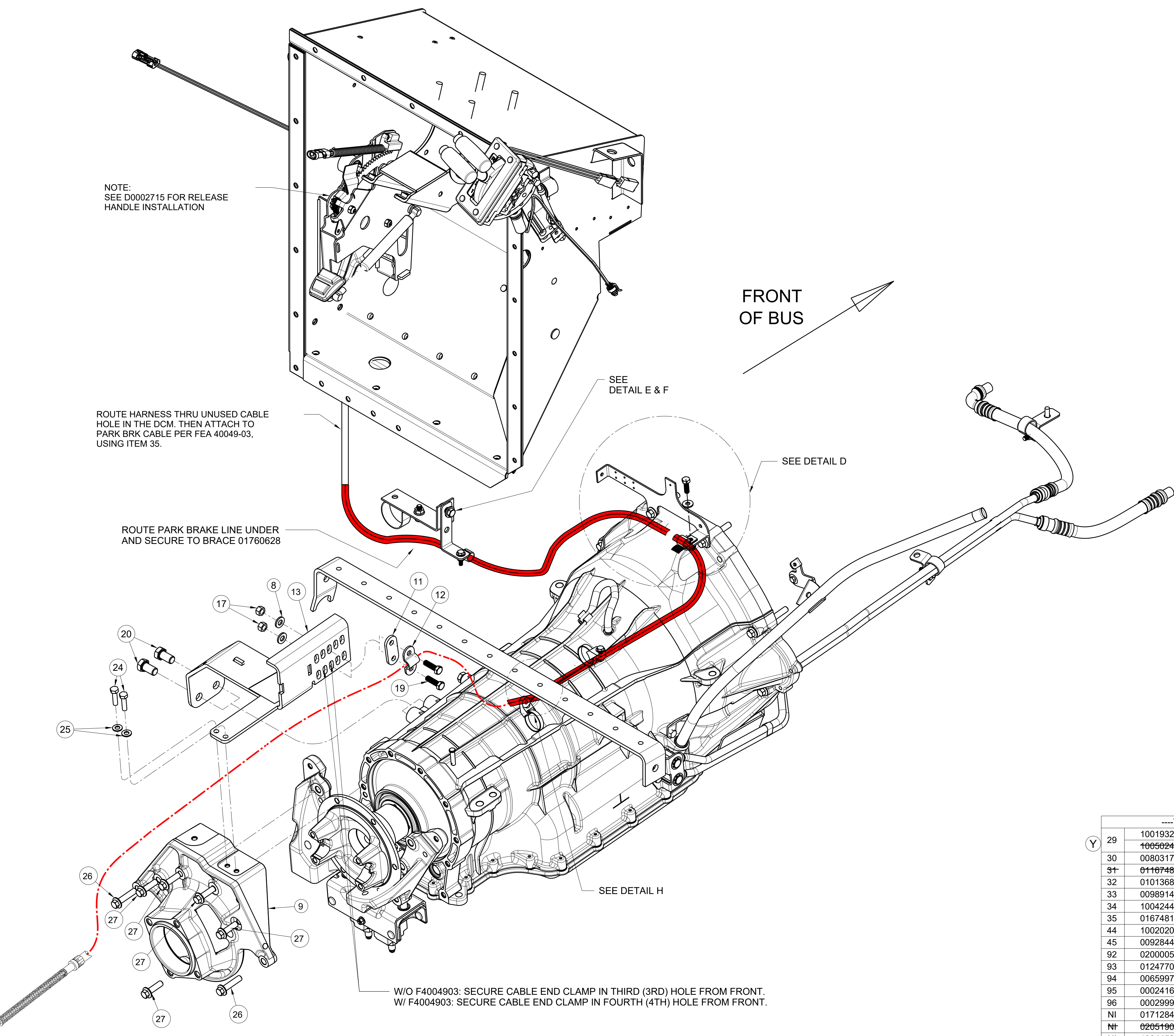
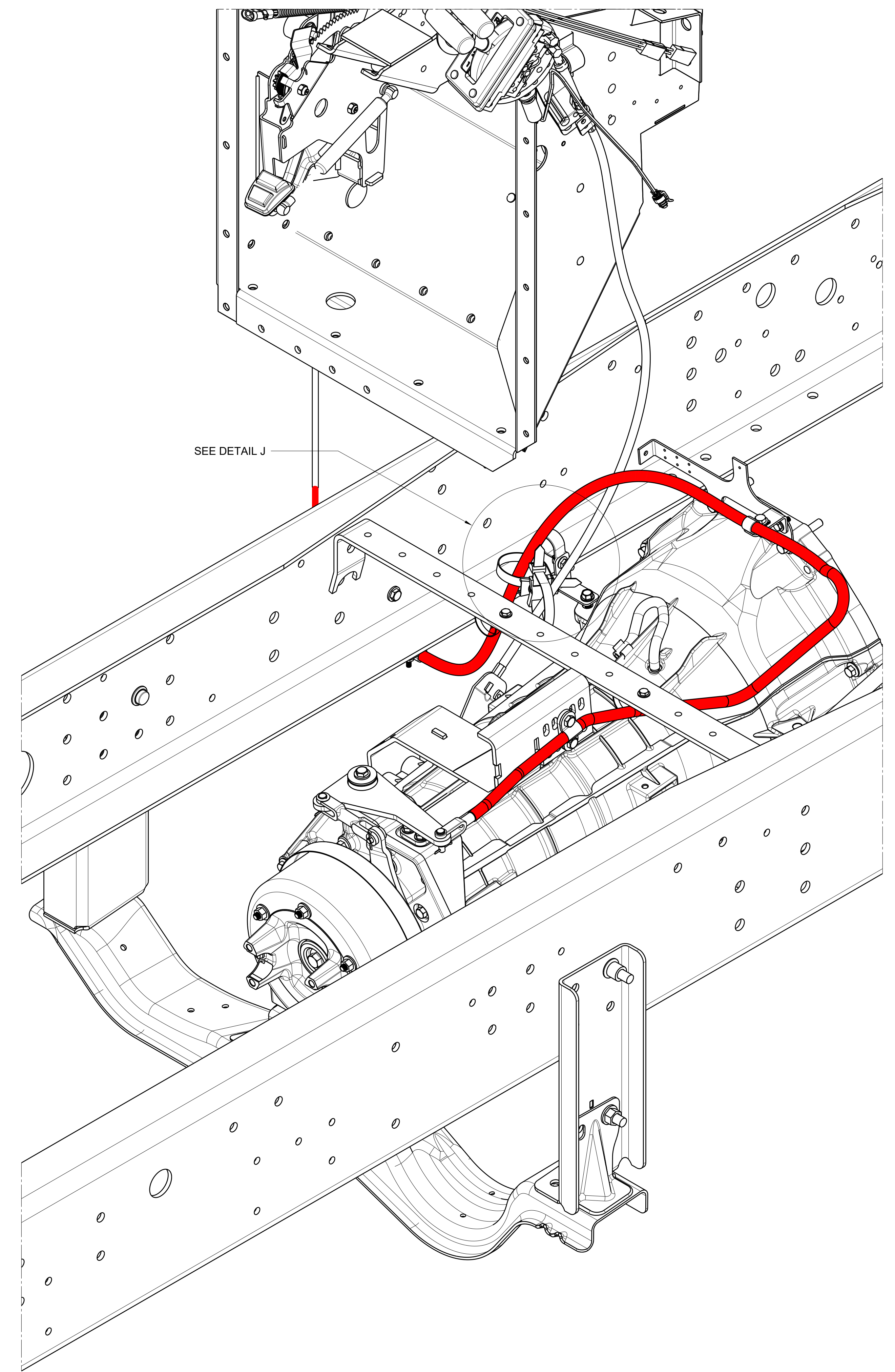

KEY	PART-NO	DESCRIPTION	QTY
1	00118761	BRAKE, PARKING, DRUM SPL100	1
2	10067577	BRAKE, PARKING, BOSCH	1
3	10002747	COVER ASSY, MTG, PARKING BRAKE, HYDRAULIC	1
4	01319607	LEVER, PARKING BRAKE ASSY, BOSCH	1
5	10056267	YOKE, BRAKE, PARKING	1
6	10020255	WELDMENT, BELLCRANK, PARKING BRAKE, EXTENDED ARM	1
7	01317429	SPACER, PARKING BRAKE LINKAGE	1
8	01107085	WASHER, FLAT, 13/32 X 13/16 X 3/32, HDN, BLK, ZN	4
9	10019591	BRACKET, MTG, PARK BRK CMPTS, FORD PROPANE, CV	1
10	01317502	YOKE, PARKING BRAKE, CLEVELAND 2708-3A	1
11	01443258	SPACER LINK, ORSCHEL N 8100131	1
12	01443241	CLAMP, CABLE, ORSCHEL N 8100108	1
13	10020262	WELDMENT, BRACKET, PARKING BRAKE, FORD TRANS, CV	1
14	00560748	WASHER, FLAT, 15/32 X 1 1/2 X 3/32, HDN, BLK, ZN	1
15	01319573	PIN, CLEVIS, 5/16, CLEVELAND 2708 1/2-3A	2
16	02008860	PIN, COTTER, 3/32 X 1, YLZNDICH	3
17	00826297	NUT, HEX HD, 3/8-16 LOCK, YEL, ZN DICH	3
18	00870451	CAPSCREW, HEX HD, 3/8-16X 2 1/2, GR8, YELZNDICH	1
19	00803213	CAPSCREW, HEX HD, 3/8-16X1 1/4, GR8, YEL, ZNDICH	2
20	10020701	CAPSCREW, HEX HD, 9/16-12X1, GR8, YEL, ZN DICH	2
21	00803239	CAPSCREW, HEX HD, 1/2-13 X 1 1/2, GR8, YELZNDICH	4
22	02001212	LOCKWASHER, SPLIT RING, 1/2, LHT, YEL, ZN DICH	4
23	01078922	WASHER, FLAT, 3/8X7/8X5/64 YELLOW ZINC DICH	6
24	01304633	CAPSCREW, HEX HD, M8-1.25X30, CL 10.9, OLVD, RBCHMT	2
25	02001048	WASHER, FLAT, 11/32 X 1 1/16 X 1/16, YEL, ZNDICH	2
26	00013655	CAPSCREW, HEX HD, M10-1.5 X 45, GRADE 10.9	2
27	10020703	CAPSCREW, HEX FLG, M10-1.50X35, GR 10.9, YEL, ZN DICH	5
28	00074309	PANEL, FLOOR, FRONT	REF
36	00803213	CAPSCREW, HEX HD, 3/8-16X1.25, GR8, YELZNDICH	6
37	00826297	NUT, HEX HD, 3/8-16 LOCK, YEL, ZN DICH	6
38	02000057	CAPSCREW, HEX HD, 1/4-20 X 1, GR 5, YEL, ZN DICH	2
39	00111133	BRACKET, MOUNTING, FUEL LINES TO ISBO7BC, BBCV	1
40	01247709	WASHER, FLAT, 17/64 ID X 5/8, YEL, ZN DICH	4
41	00659979	NUT, HEX, FLANGE SER, 1/4-20, BLACK ZINC	2
42	00021926	CLAMP, LOOP, .625	2
43	01317247	BRACKET, ATCH, BRAKE LINE TO FRAME	1
46	00839027	NUT, HEX HD, 3/8-16, GR G, SM FLG LK, YEL, ZNDICH	1
47	10019598	CAPSCREW, HEX HD, FLNGD, M10X1.00X65, FORD 6R140	REF
48	02001045	NUT, HEX HD, 25-20, LOCKING, YEL, ZNDICH	1
49	02000156	CAPSCREW, HEX HD, 5/16-24X 1, GR 5, YEL, ZN DICH	1
50	02001121	WASHER, FLAT, 5/16 X 3/4 X 5/64, YEL, ZN DICH	1
51	02004257	NUT, HEX HD, 5/16-24, FLG, PRVLG TORQ, YELZNDICH	1
52	00870477	CAPSCREW, HEX HD, 1/4-20 X 1, GR 8, YEL, ZN DICH	+
53	00024168	MOUNT, HEAVY DUTY, .25 HOLE SIZE	+
54	00799489	STRAP, TIE, PANHUFF	+
89	10001134	PIN, CLEVIS, 3/16 X 1.25	+
89	00971978	NUT, HEX HD, 5/16, YELLOW DICHROMATE	+
96	0001454	CLAMP, MTG, TIE CABLE	+
91	00029998	TIE, CABLE, 250LB	1

---THESE ITEMS ARE ONLY WITH FEATURE OPTION 30017-01/02---			
80	00003844	BRACKET, FUEL LINE STD-OFF, ISC, WITEX U-BLTS	1
81	01107937	CLAMP, LOOP, 2.00, INSULATED COV-3313	1
82	01107085	WASHER, FLAT, 13/32 X 13/16 X 3/32, HDN, BLK, ZN	1
83	00559195	CAPSCREW, HEX HEAD, 3/8-16X1, GR8, YEL, ZN DICH	1
84	00839027	NUT, HEX HD, 3/8-16, GR G, SM FLG LK, YEL, ZNDICH	1
85	01489434	TRIM, VINYL, BLACK, DOUBLE LIP	3*
86	00029998	TIE, CABLE, 250LB	2
87	00029253	SADDLE, DUAL SWIVEL, MOUNT	1

---THESE ITEMS ARE ONLY WITH FEATURE OPTION 40049-03---				REMARKS
29	10019322	LEVER ASSY, PARK BRAKE, W/PALM RELEASE BUTTON, CV	1	
30	10050246	LEVER ASSY, BRAKE, PARK, TRIGGER GUARD WINTERLOCK	1	W/0 40051-09/10
30	00803171	CAPSCREW, HEX HD, 3/8-16NCX1-1/2, GR8, YELZNDICH	3	
31	01167485	WASHER, FLAT, 11/32 X 1 1/16 X 5/64, HDN, BLK, ZN	5	
32	01013689	NUT, HEX HD, 3/8-16, WASHER SER, YEL, ZN DICH	3	
33	00889145	CAPSCREW, HEX HD, 5/16-18 X 1, GR8, YEL, ZNDICH	2	
34	10042449	PLATE, MTG, HANDBRAKE PRODUCTION ONLY, BBCV	1	
35	01674811	TIE, CABLE, NYLON, PANDUIT NO. PTL21-C30	5	
44	10020209	DECAL, PARKING, BRAKE, RELEASE W/PALM BUTTON	1	
45	00928440	NUT, ACORN, 3/8-16, YEL, ZN DICH, LOW CROWN	1	
92	02000057	CAPSCREW, HEX HD, 1/4-20 X 1, GR 5, YEL, ZN DICH	1	
93	01247709	WASHER, FLAT, 17/64 ID X 5/8, YEL, ZN DICH	1	
94	00659979	NUT, HEX, FLANGE SER, 1/4-20, BLACK ZINC	1	
95	00024168	MOUNT, HEAVY DUTY, .25 HOLE SIZE	1	
96	00029998	TIE, CABLE, 250LB	1	
NI	01712843	LUBRICANT, LPS, NO. 3, GALLON	.01	
NI	02051902	SEALANT, SILICONE, BLACK, CARTRIDGE	+	
NI	10044528	TUBE, GREASE, MULTIFAK EP-2	.05	

BOLT NO.	FASTENER TORQUE lbs-ft
18	27 - 30
20	73-82
21	91-97
24	22 - 25
26	53 - 58
27	53 - 58
32	9 - 12

FOR ALL OTHER FASTENERS SEE THE DESIGNATED FASTENERS TORQUE CHART IN THE ENGINEERING GENERAL INSTRUCTIONS.

- NOTE:
1. CABLE ASSEMBLY MUST BE A MINIMUM 3.50 INCH RADIUS. BENDS SHOULD BE AS LARGE AS POSSIBLE.
  2. SPRAY LPS NO.3 LUBRICANT AND RUST INHIBITOR (01712843) ON ALL YOKE AND PIN ASSEMBLIES AFTER ASSEMBLY.
  3. INSTALLATION MUST MEET FMVSS 105.
  4. ITEM# 34, SHIPPING PLATE, WILL NOT BE REUSED AND SHOULD BE DISPOSED OF AT BODY MOUNT.
  5. ITEM# 30, 31 & 32, SHIPPING CAPSCREWS TO BE USED TO MOUNT PARKING BRAKE TO FLOOR.
  6. RIGHT FRONT BOLT ONLY TO BE INSTALLED THREADS UP TO REDUCE INTERFERENCE WITH CABLE.
  7. SEE DETAIL A FOR SETTING PARKING BRAKE.

ALL DETAIL VIEWS ON SHEET 3

SEE SHEET 2 FOR PARK BRAKE CABLE ROUTING WITH RH PARK BRAKE 40049-03

BBCV W/F40433-02 TRANSMISSION W/HYD BRAKES AND FORD ENGINE

UTC 3/10/2022 7:37:57 AM

CONFIDENTIAL

The information herein is confidential business information and may not be copied or used for any purpose unless permission is expressly granted in writing by Blue Bird Corporation.

Copyright 2020 All Rights Reserved

Blue Bird Corporation  
Fort Valley, Georgia, U.S.A.

Scale: 1/1  
Inch: AA  
Sheet: 1/4

DIAGRAM, INSTL, PARK BRK, FORD PROPANE, CV

DR 11/25/10 BY TTL  
APP 11/25/10 BY HH

D0007365



REVISION	Y	12/16/2020	Project	Wks	REDRAWN IN 3DK; DELETED PICTURES FROM SHEET 3; UPDATED NOTE 7 ON SHEET 4; SEE SHEET 1 PER TCR# 110260
DR	TTL	APP BH	B14261	...	SEE SHEET 1 & 3
REVISION	Z	3/10/2021	Project	Wks	...
DR	AJ	APP AJ	B15270	...	SEE SHEET # 3
REVISION	AA	3/10/2022	Project	Wks	...
DR	TTL	APP SM	B15602	...	SEE SHEET # 3

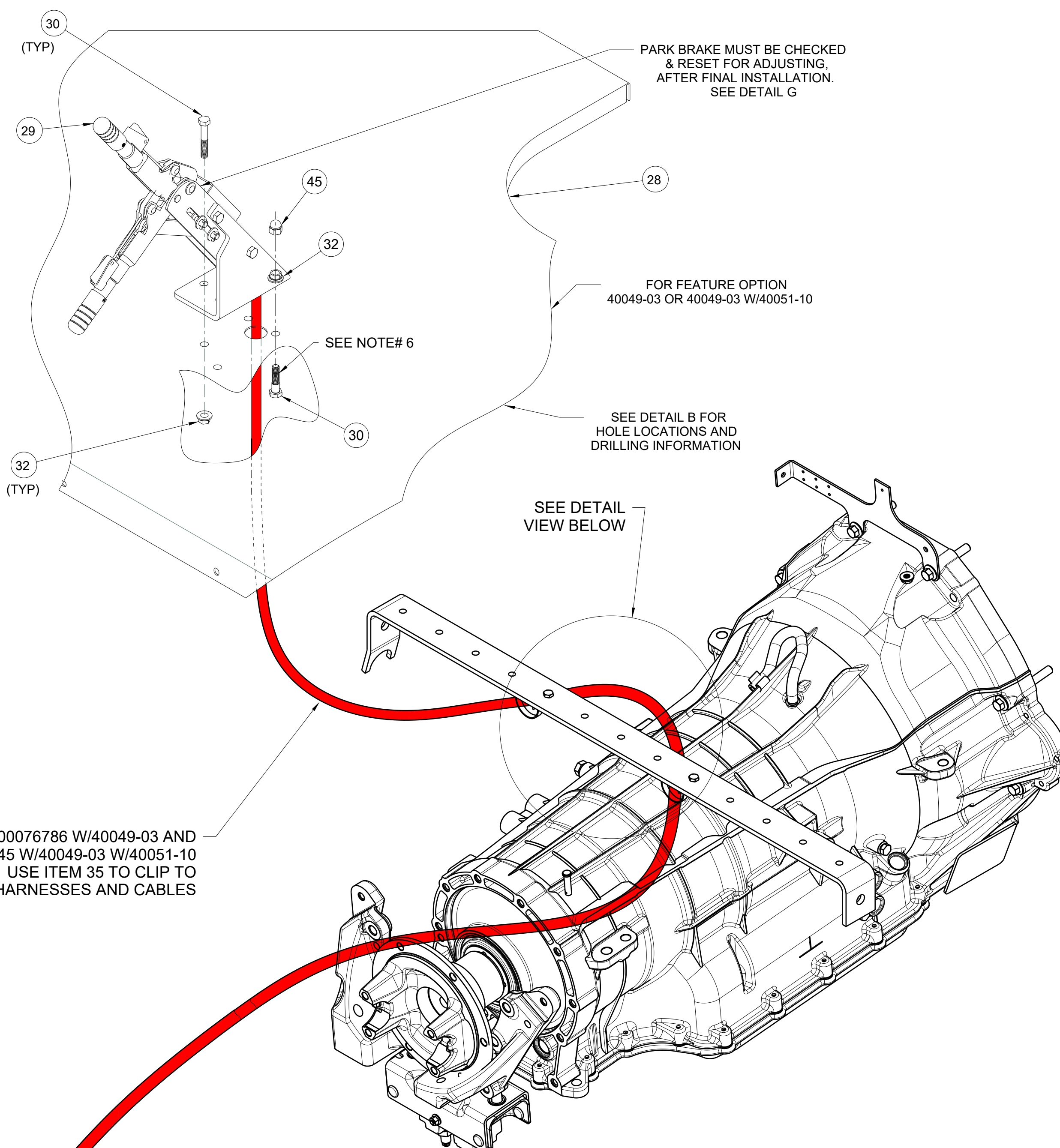
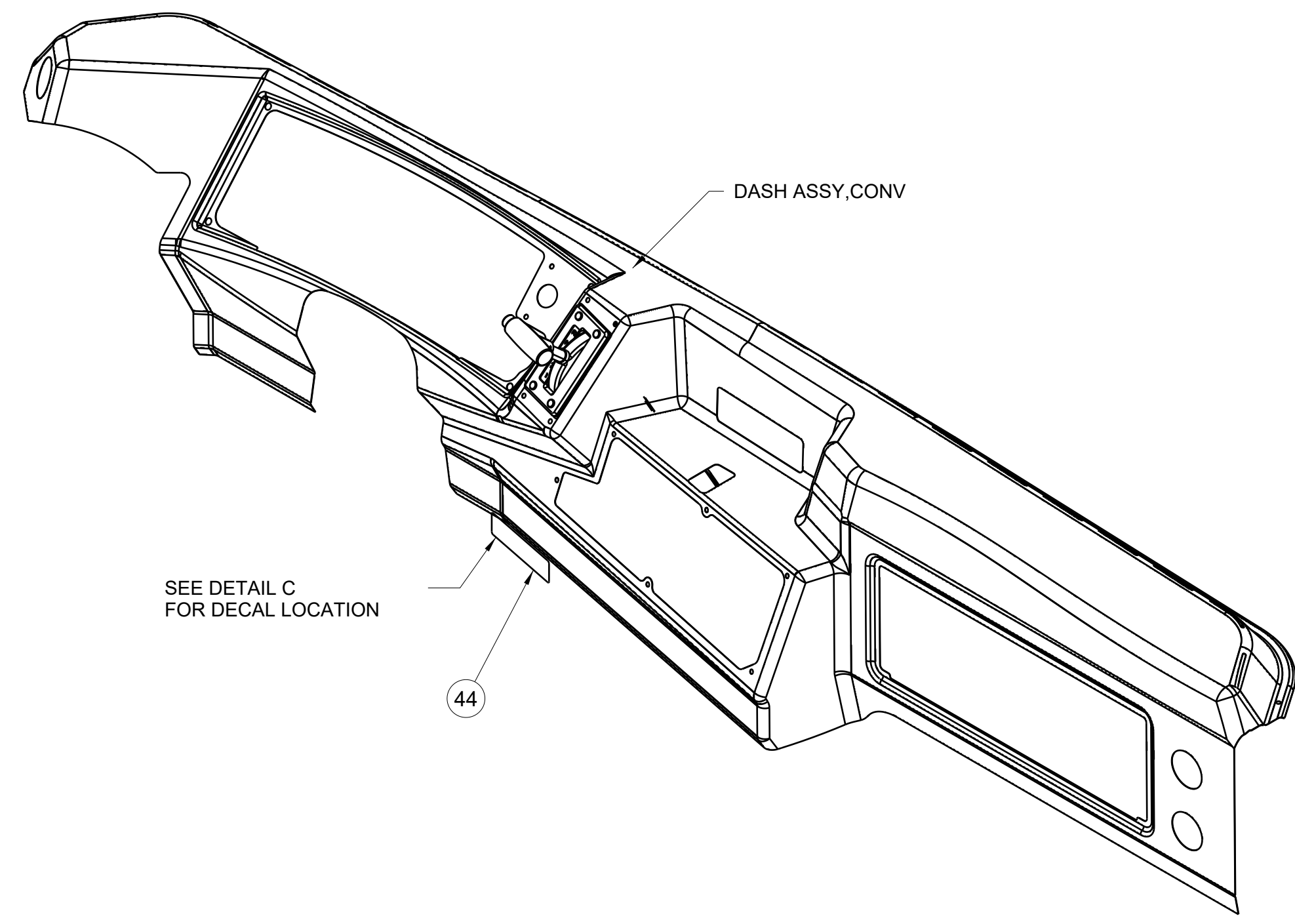

HARNESSES 00076786 W/40049-03 AND HARNESSES 10052645 W/40049-03 W/40051-10 USE ITEM 35 TO CLIP TO EXISTING HARNESSES AND CABLES

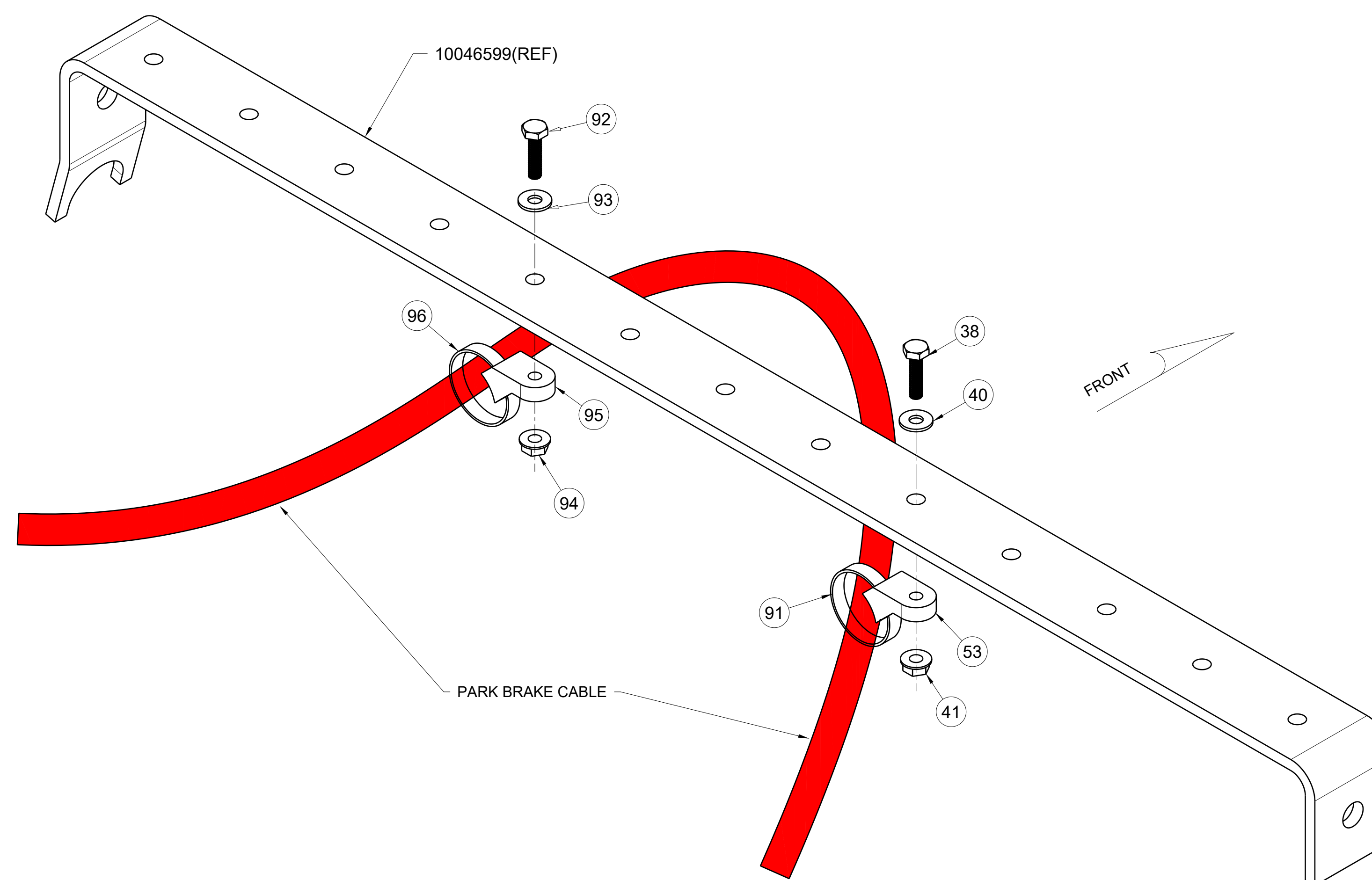
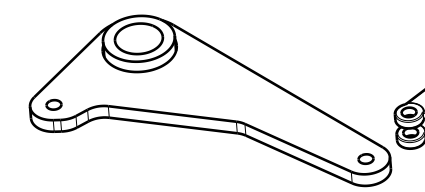

**PARK BRAKE CABLE ROUTING WITH RH PARK BRAKE 40049-03**

UTC 3/10/2022 7:38:15 AM

MATERIAL:		CONFIDENTIAL The information herein is confidential business information and may not be copied or used for any purpose unless permission is expressly granted in writing by Blue Bird Corporation. Copyright 2020 All Rights Reserved	
WEIGHT:	FINISH (1)RAW (1)PRIME (1)PAINT (1)OTHER SPEC #	Project	SCALE
COLOR NAME	GLOSS %	Blue Bird Corporation Fort Valley, Georgia, U.S.A.	1/1
NOTES:	TOLERANCE ON ALL DIMENSIONS IS PLUS (.06) OR MINUS (.06) (UNLESS OTHERWISE SPECIFIED)	DIAGRAM:INSTL.PARK BRK,FORD PROPANE.CV	AA
INACTIVATES NOS.	DO NOT SCALE	DR 11/25/10 BY TTL	2/4
		APP 11/25/10 BY HH	E D0007365



REVISION	Y	12/16/2020	Project	Wds	REDRAWN IN 3DK. DELETED PICTURES FROM SHEET 3. UPDATED NOTE 7 ON SHEET 4. SEE SHEET 1 PER TCW# 110269
DR	TTL	APP	BH	B14261	...
REVISION	Z	01/05/2021	Project	Wds	REMOVED BRACKET 10MMGMS FROM ALL VIEW, BUT REPLACED IT WITH 10070232 IN DETAIL D. W/ GAS REPLACED 1006134 WITH 0135623.
DR	AJ	APP	AJ	015270	...
REVISION	AA	3/10/2022	Project	Wds	PICTORIALLY UPDATED DRAWING FOR GUARD BRACKET CHANGE PER TCW# 120336.
DR	TTL	APP	SM	0156023	01760928

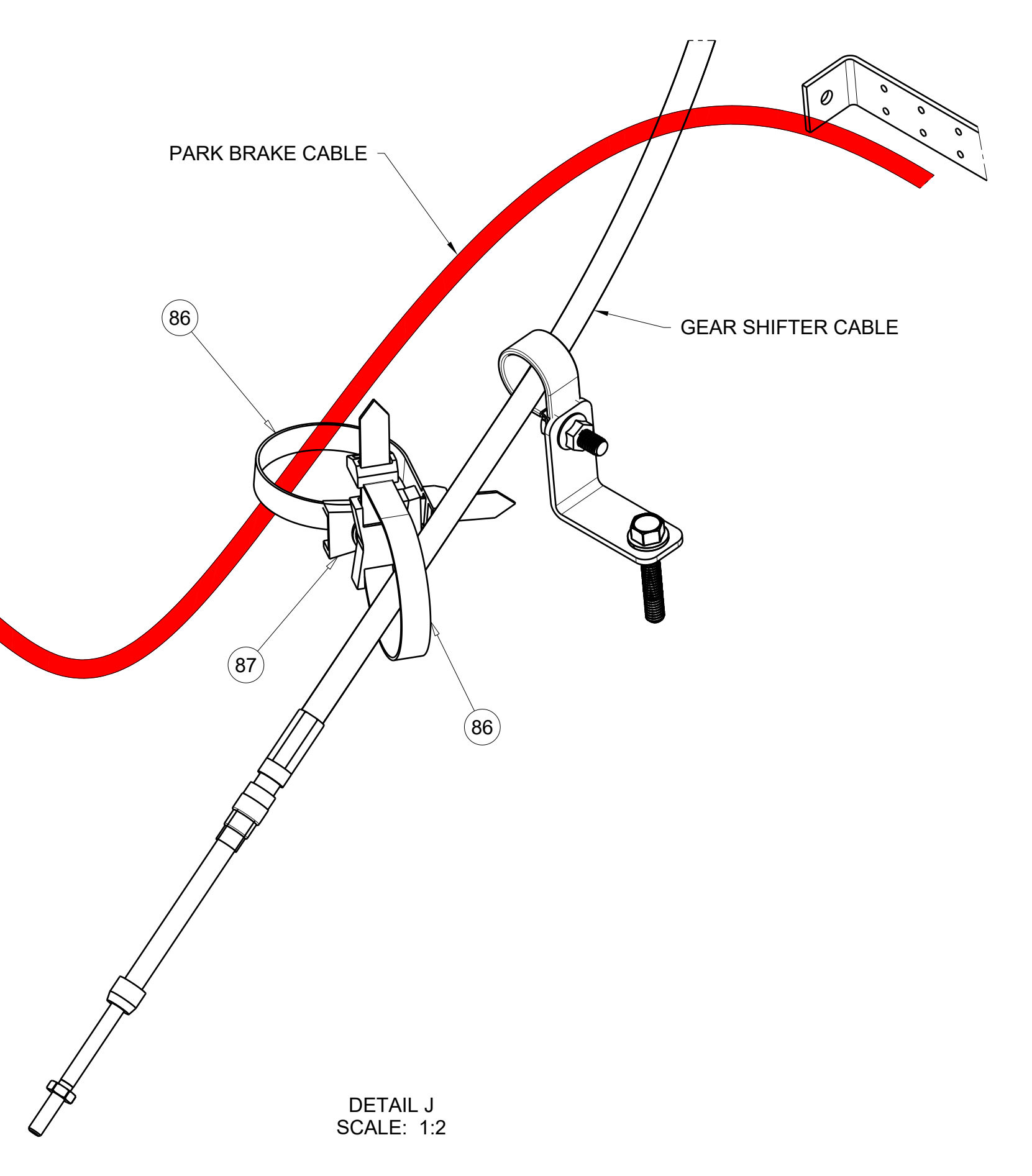
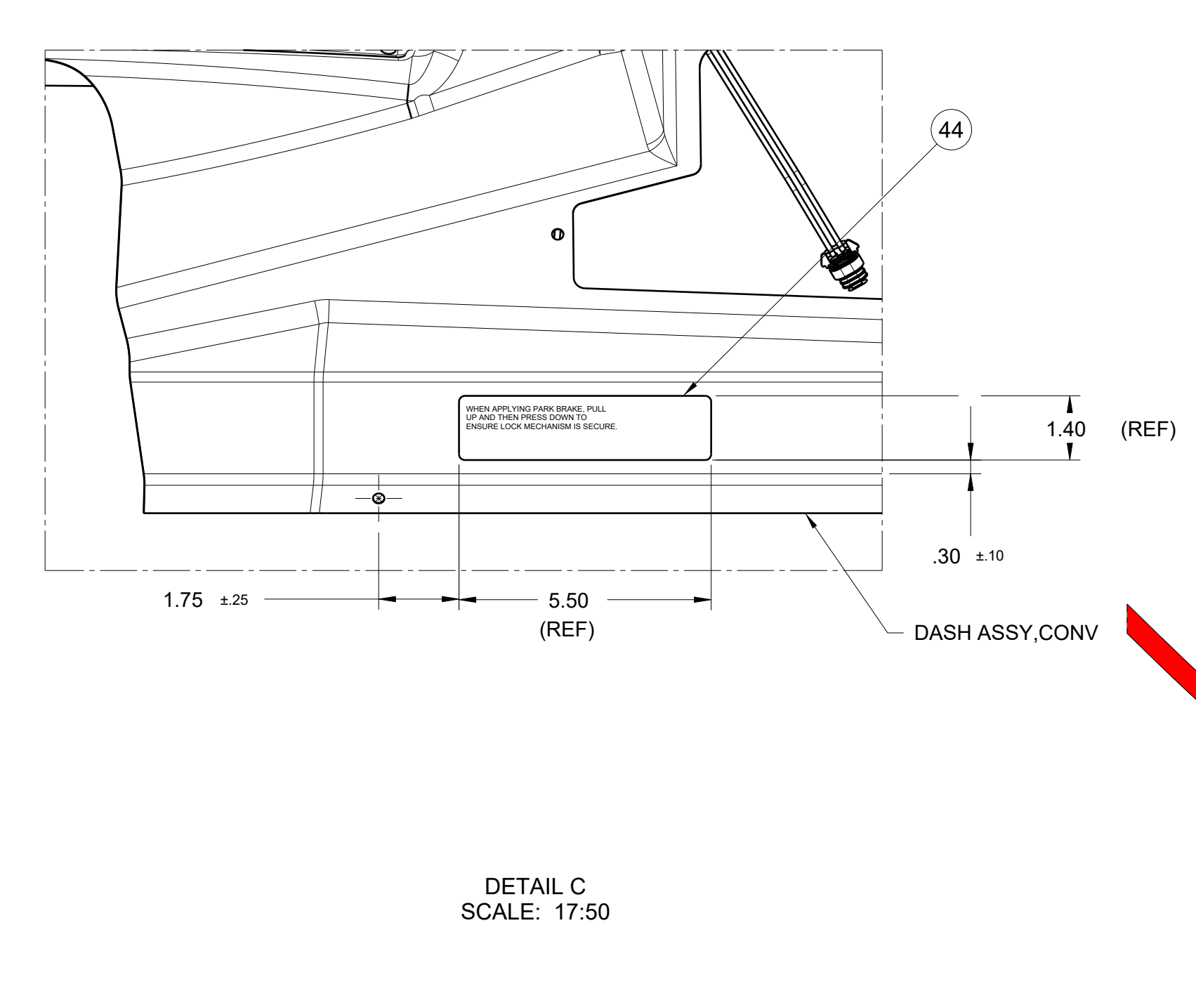
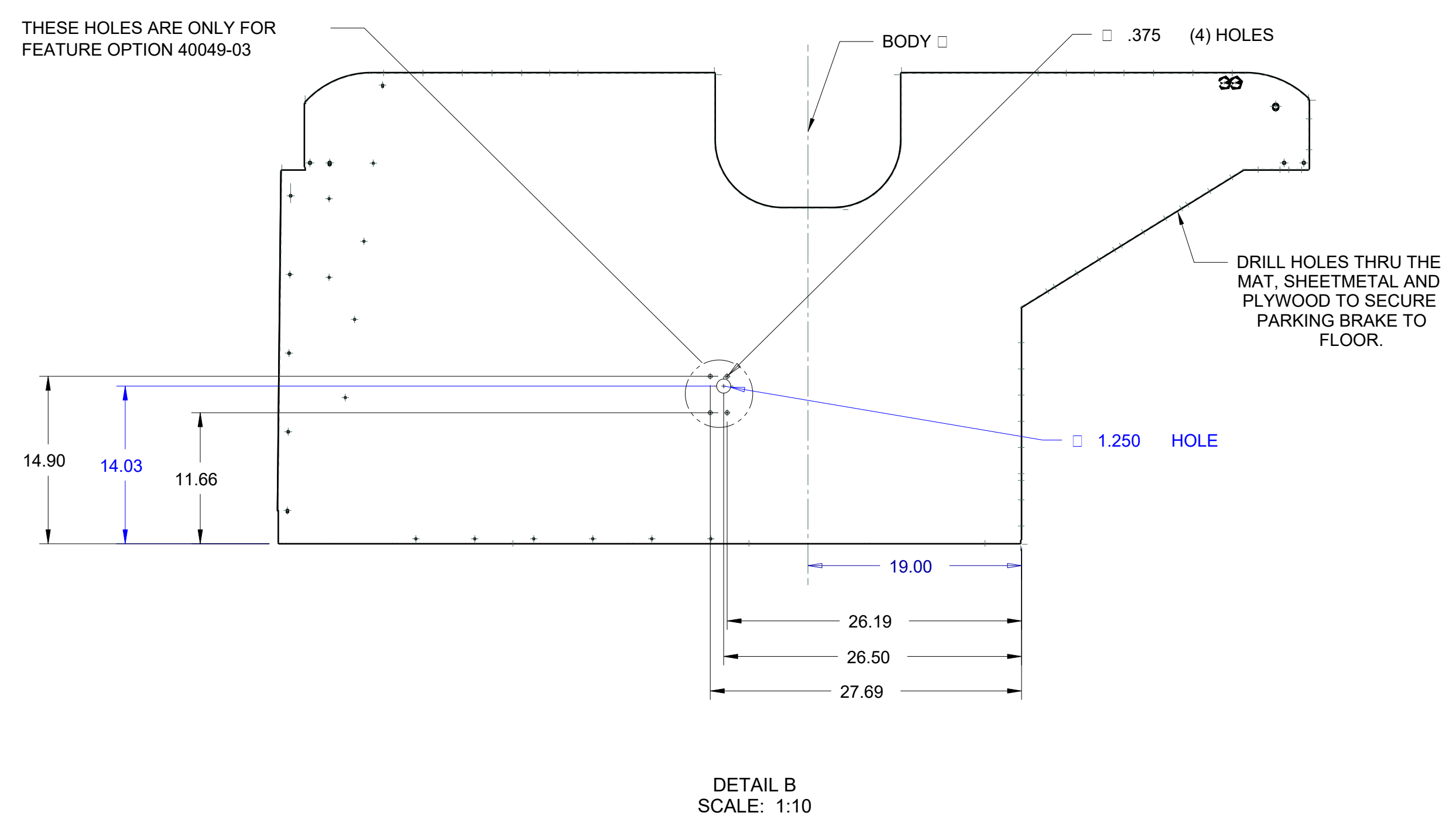
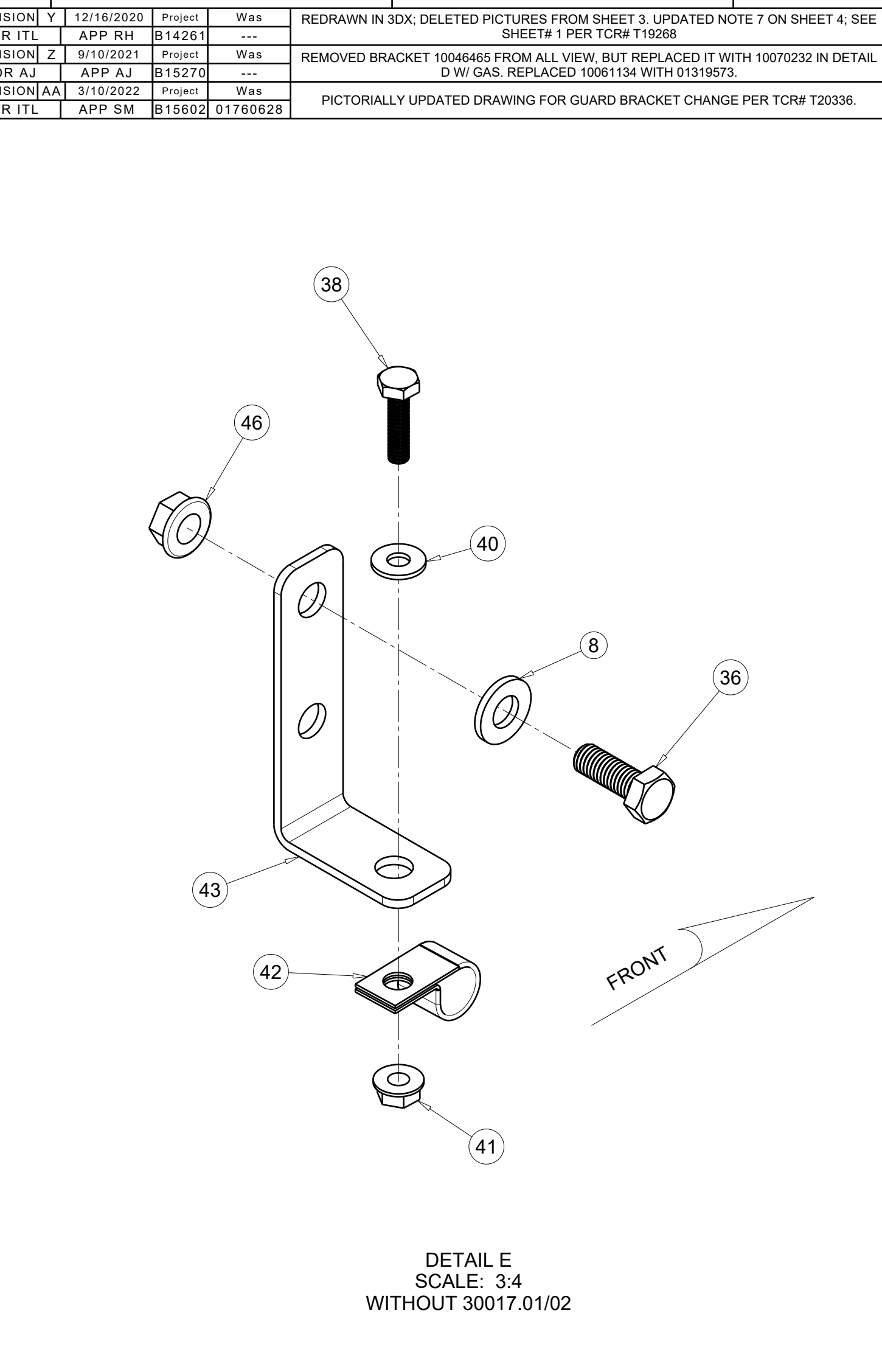
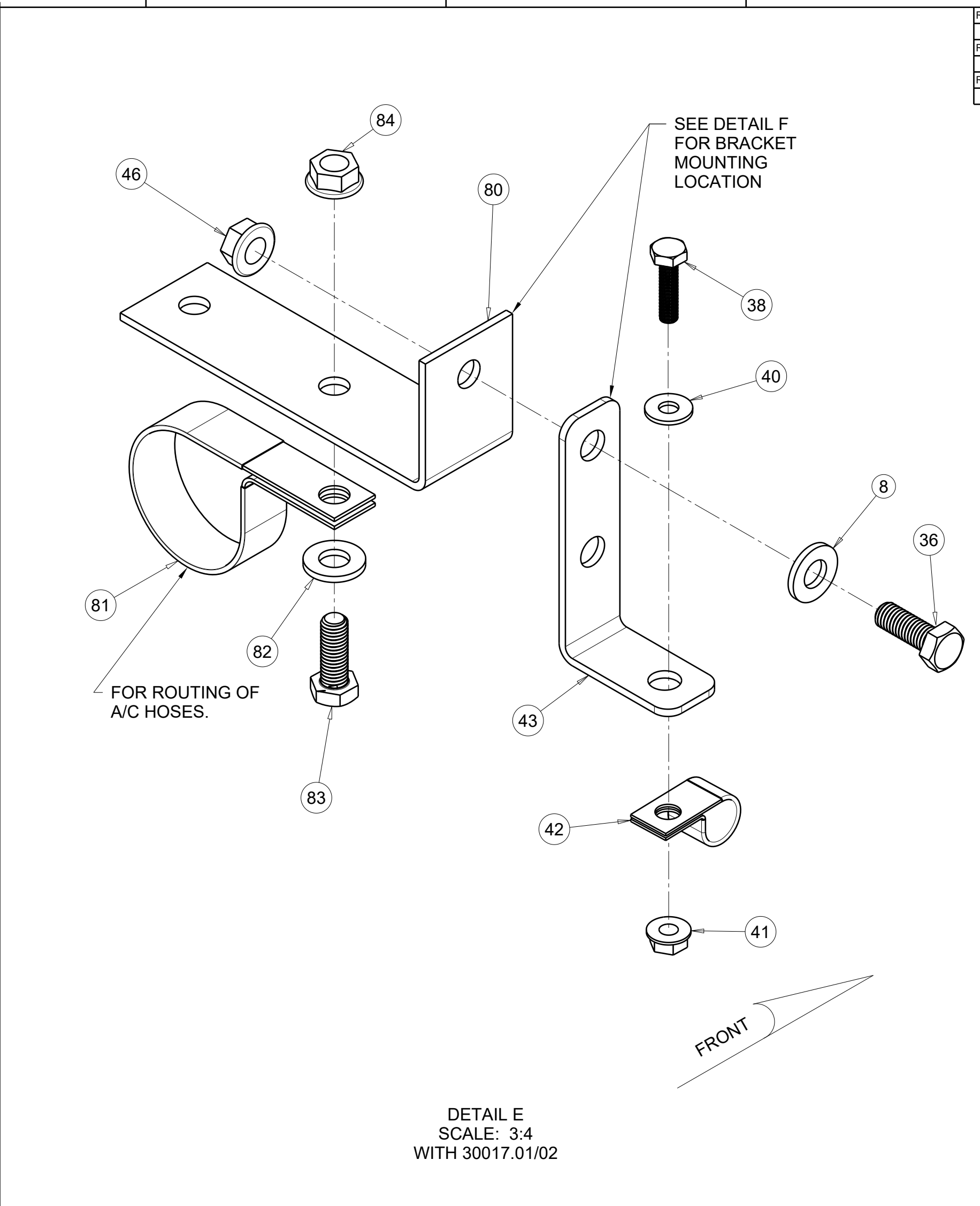
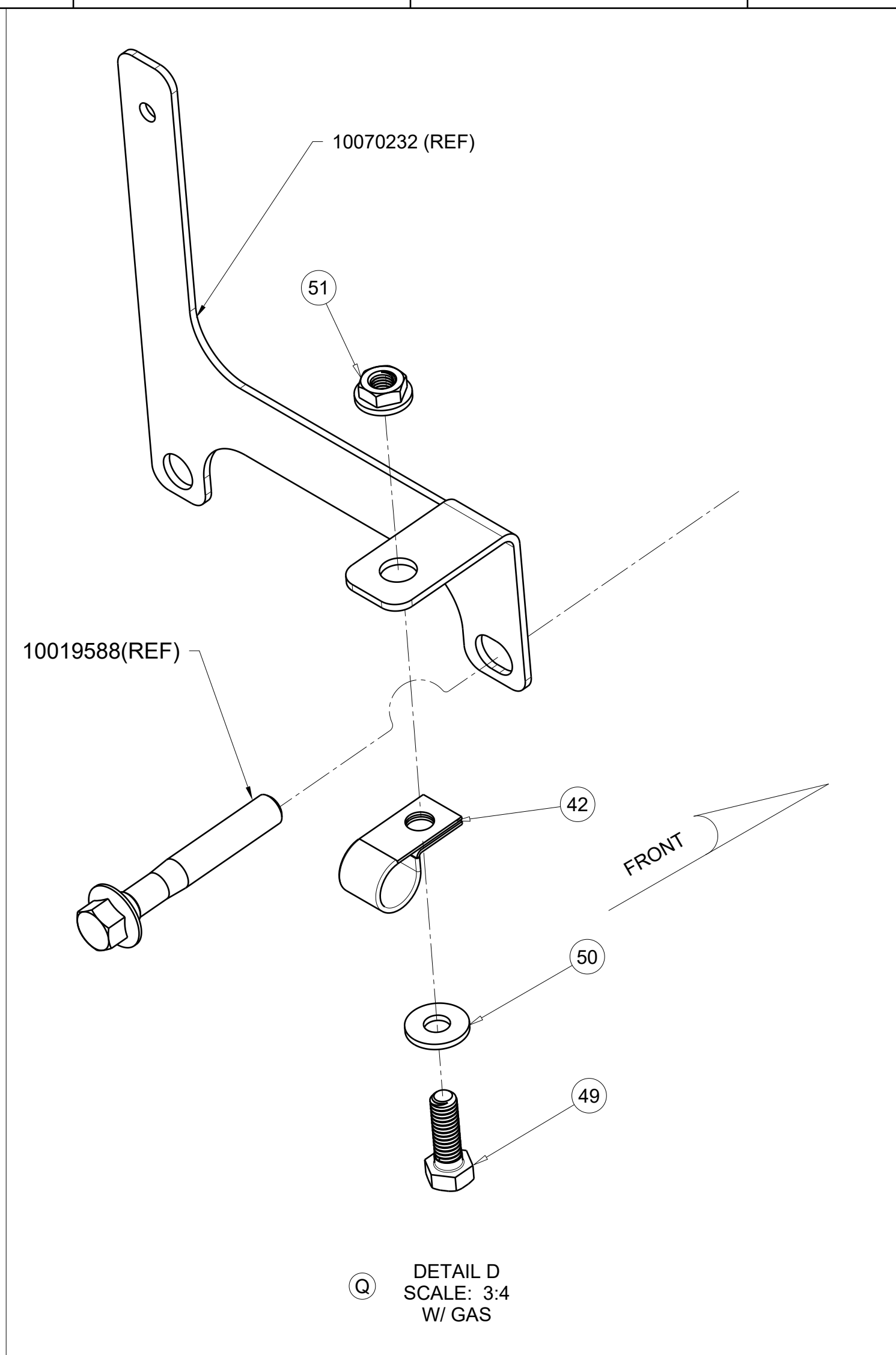
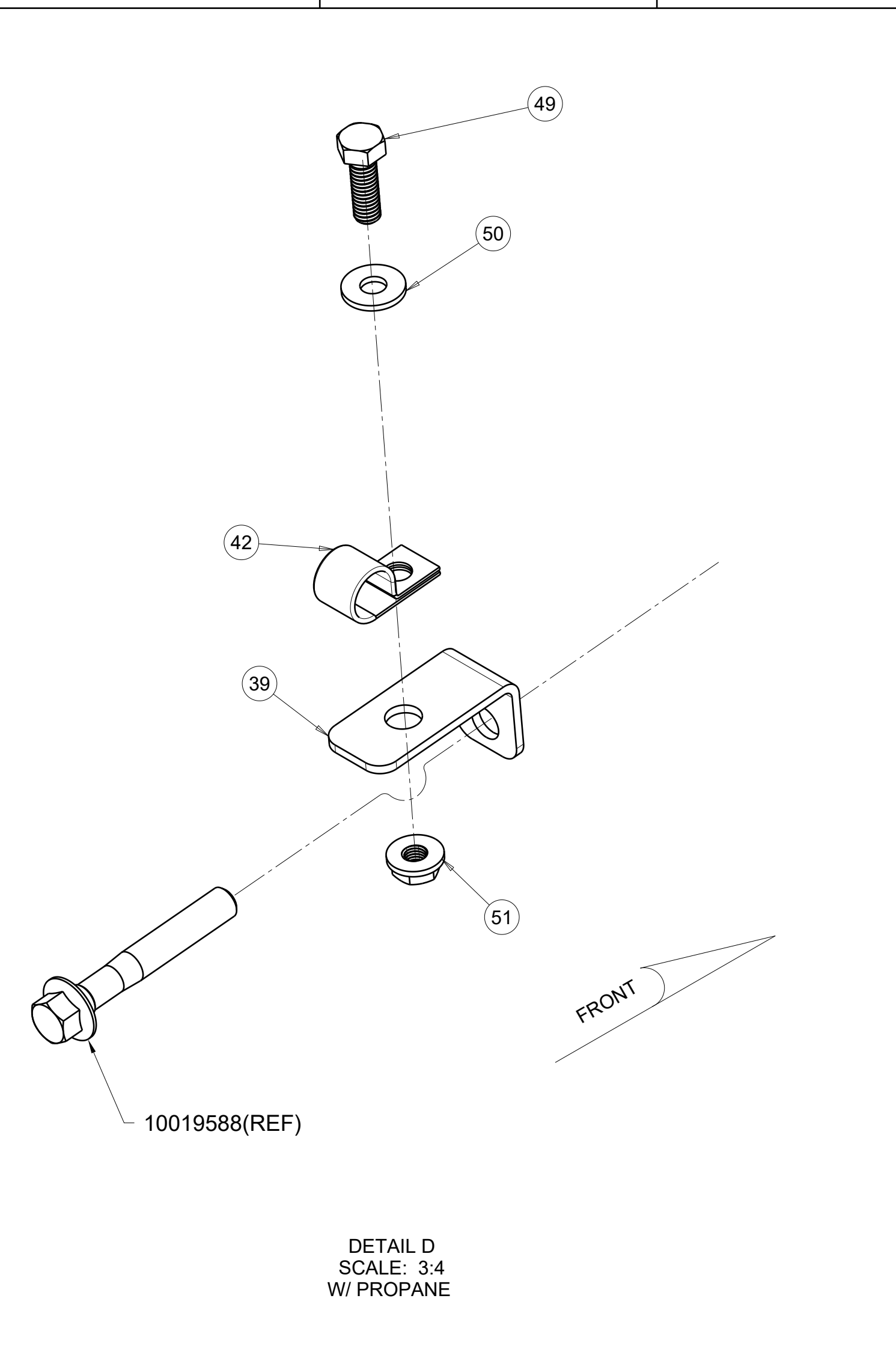
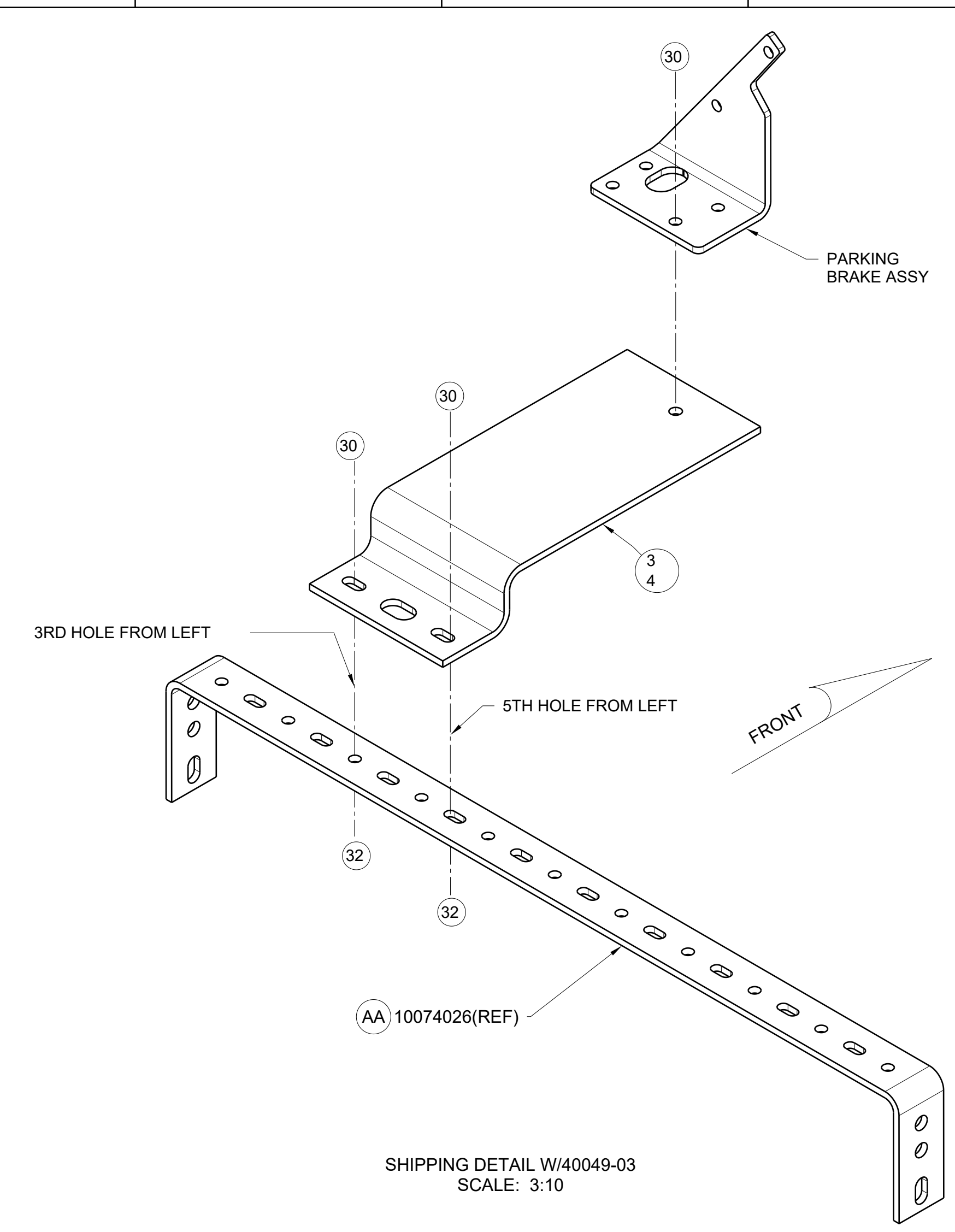

THIS VIEW REMOVED  
SEE SHEET 4

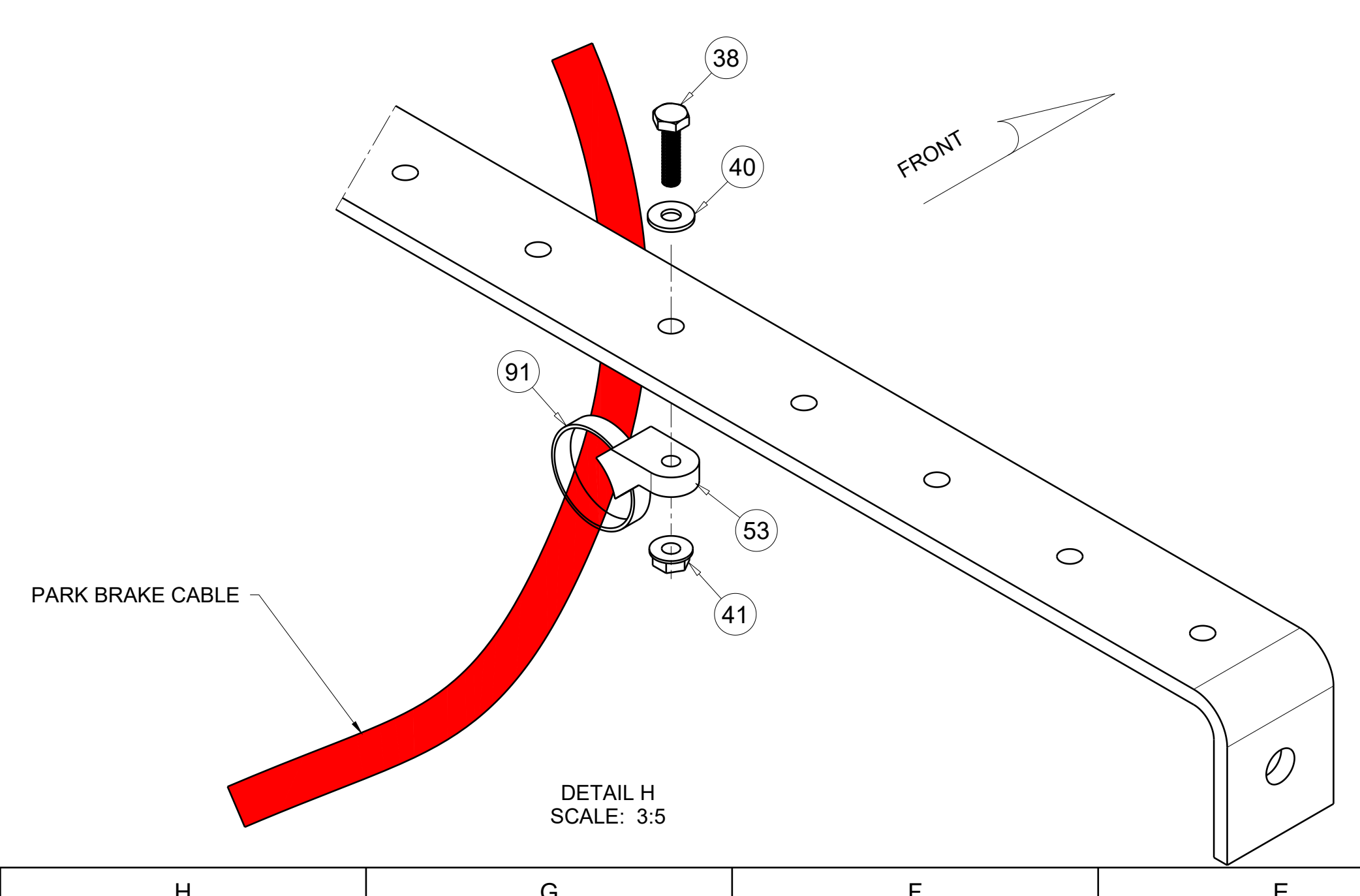
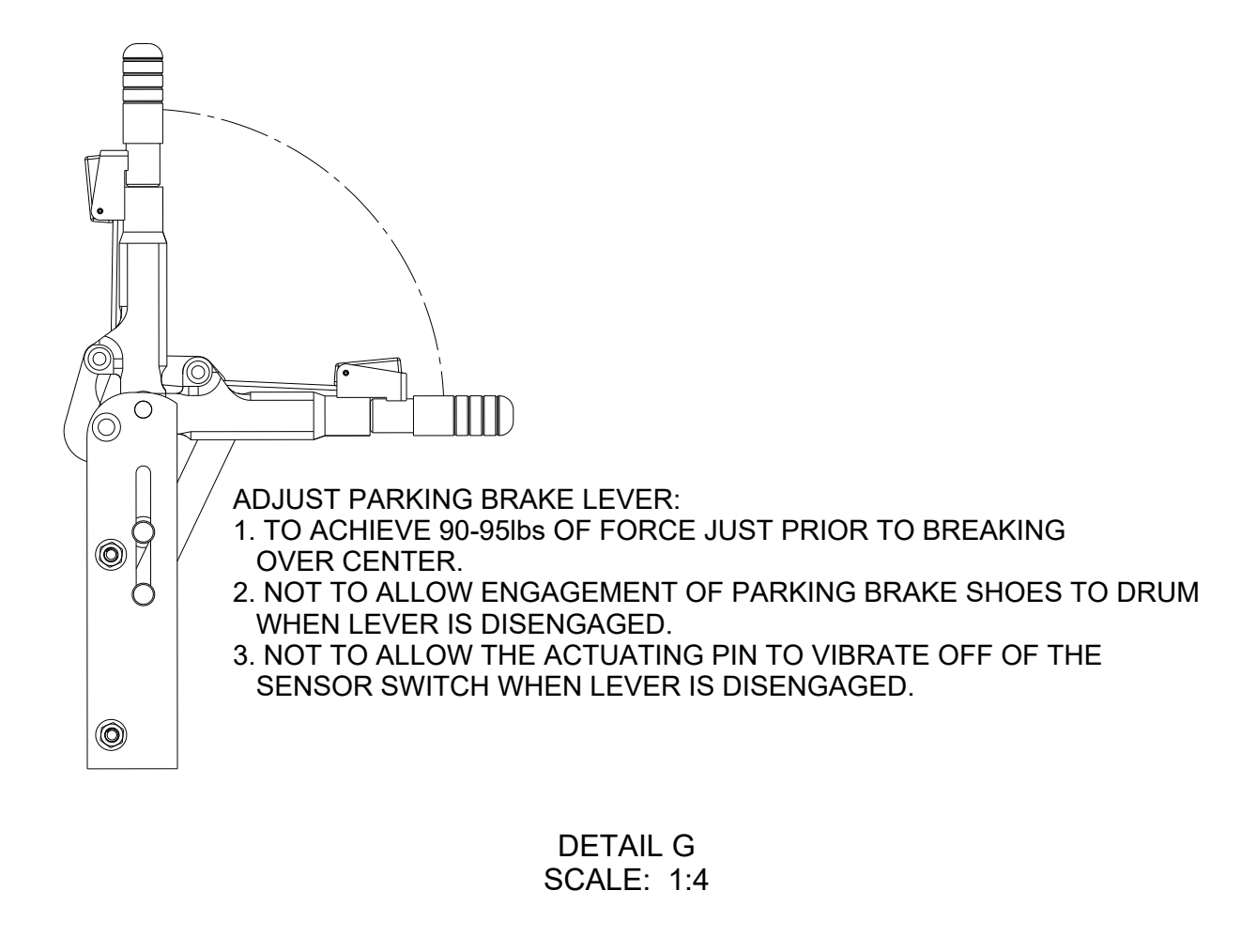
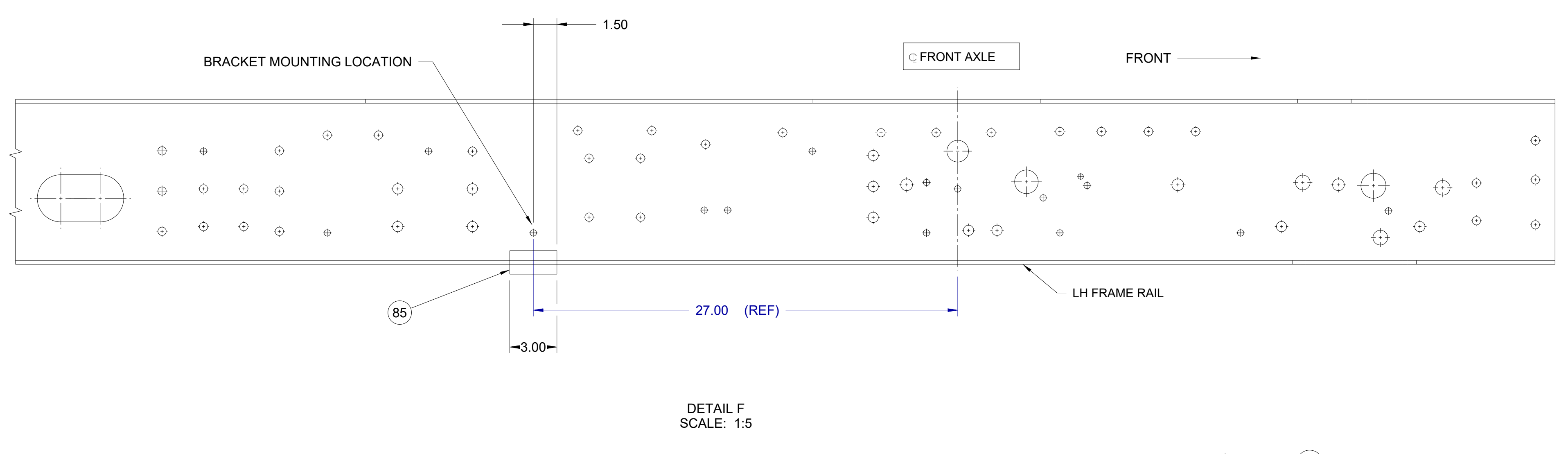

UTC 3/10/2022 7:38:19 AM

MATERIAL:		CONFIDENTIAL	
WEIGHT:		The information herein is confidential business information and may not be copied or used for any purpose unless permission is expressly granted in writing by Blue Bird Corporation.	
FINISH (1)RAW (1)PRIME (1)PAINT (1)OTHER SPEC #		Copyright 2020 All Rights Reserved	
TOLERANCE ON ALL DIMENSIONS IS PLUS (.00) OR MINUS (.00) (UNLESS OTHERWISE SPECIFIED)		Blue Bird Corporation Fort Valley, Georgia, U.S.A.	
INACTIVES NOS:		Project: B14261	
		Scale: 1/10	
		Rev: AA	
		DIAGRAM:INSTL.PARK BRK,FORD PROPANE.CV	
		DR 11/25/10 BY TTL	
		APP 11/25/10 BY HH	
		E D0007365	
		3/4	



REVISION	Y	12/16/2020	Project	Was	REDRAWN IN 3DK; DELETED PICTURES FROM SHEET 3; UPDATED NOTE 7 ON SHEET 4; SEE SHEET 1 PER TOR# 110260
DR	ITL	APP	BH	B14261	...
REVISION	Z	3/10/2021	Project	Was	SEE SHEET 1 & 3
DR	AJ	APP	AJ	B15270	...
REVISION	AA	3/10/2022	Project	Was	SEE SHEET #3
DR	ITL	APP	SM	B15602	...

1. SET CABLE END CLAMP IN THIRD (3RD) MOUNTING HOLE LOCATION (MIDDLE OF BRACKET). ENSURE FOOT PEDAL OR HAND LEVER IS IN THE FULLY RELEASED POSITION. WITH HAND LEVER (F4004903) SET END CLAMP IN THE FOURTH (4TH) MOUNTING HOLE LOCATION.

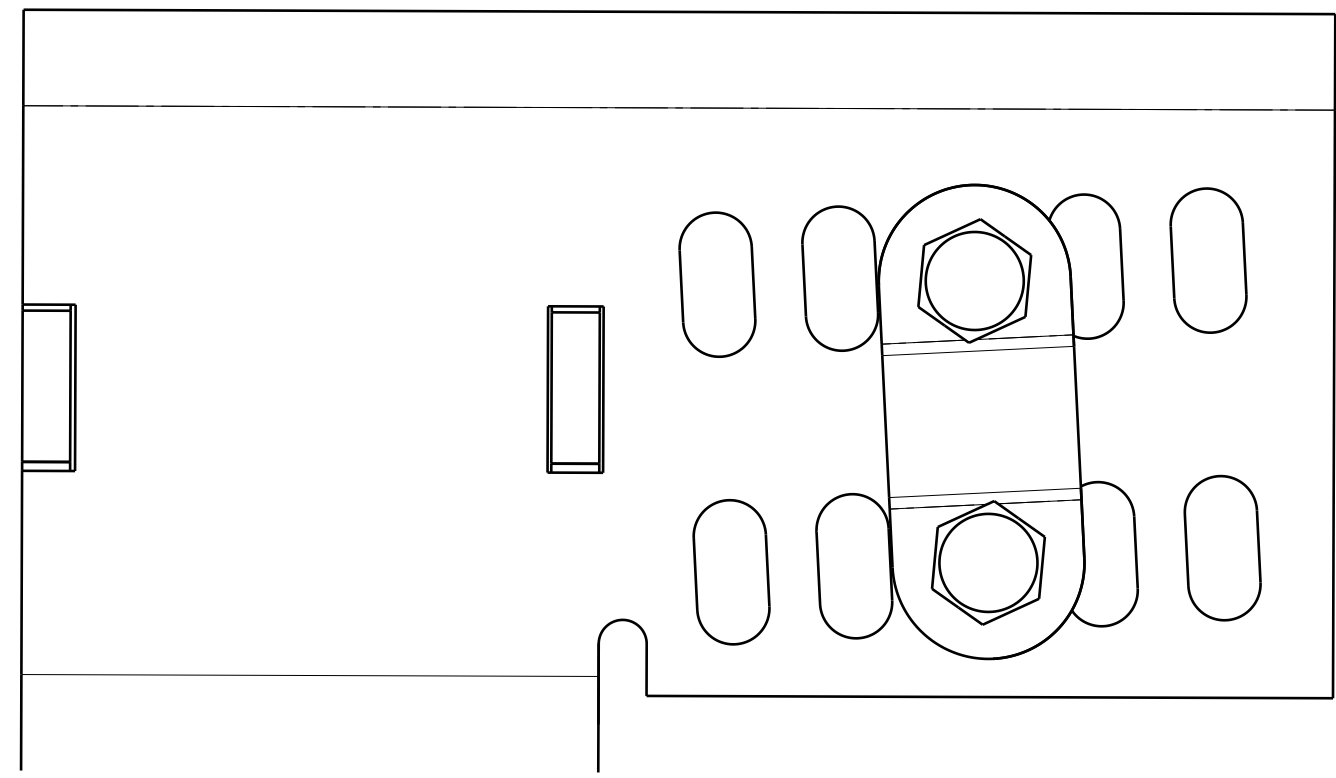

W/O F4004903

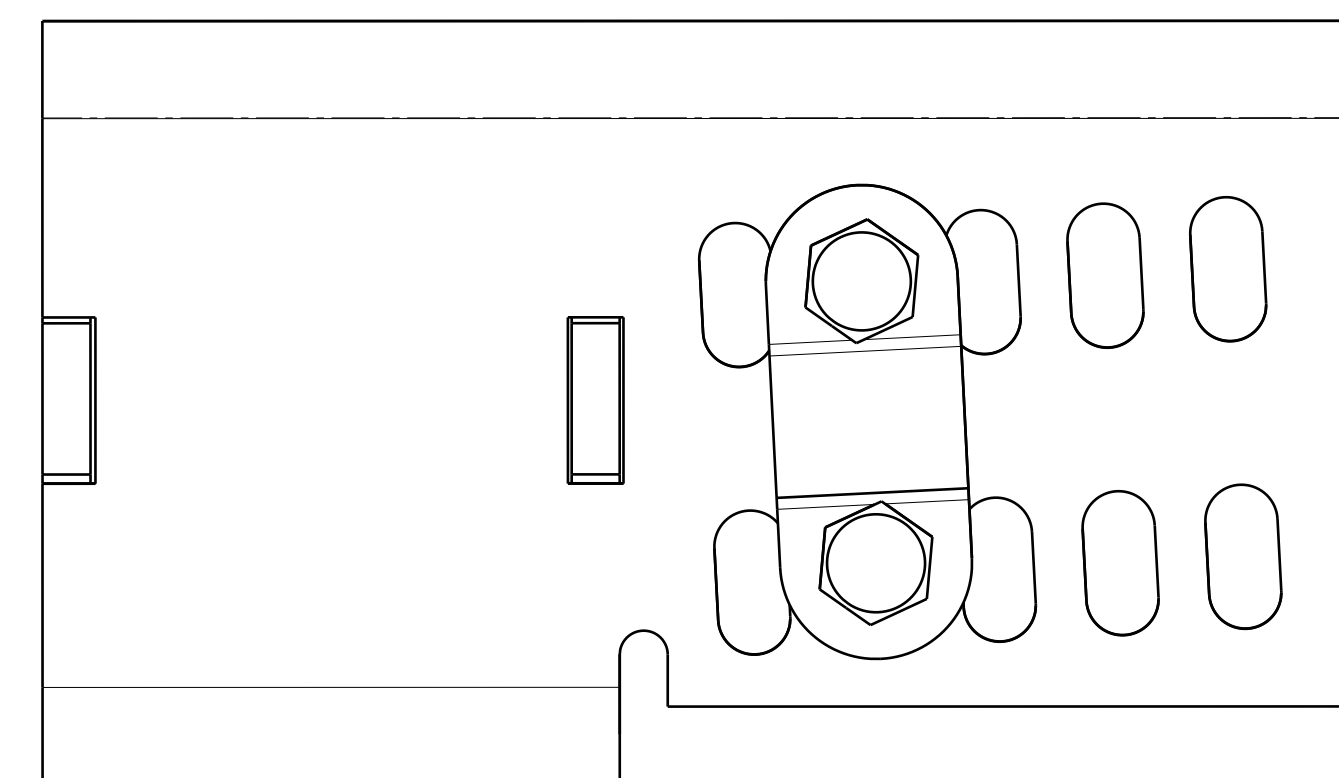

W/ F4004903

FRONT

FRONT

2. ENSURE THE CABLE IS SECURED FLUSH WITH THE CABLE END CLAMP

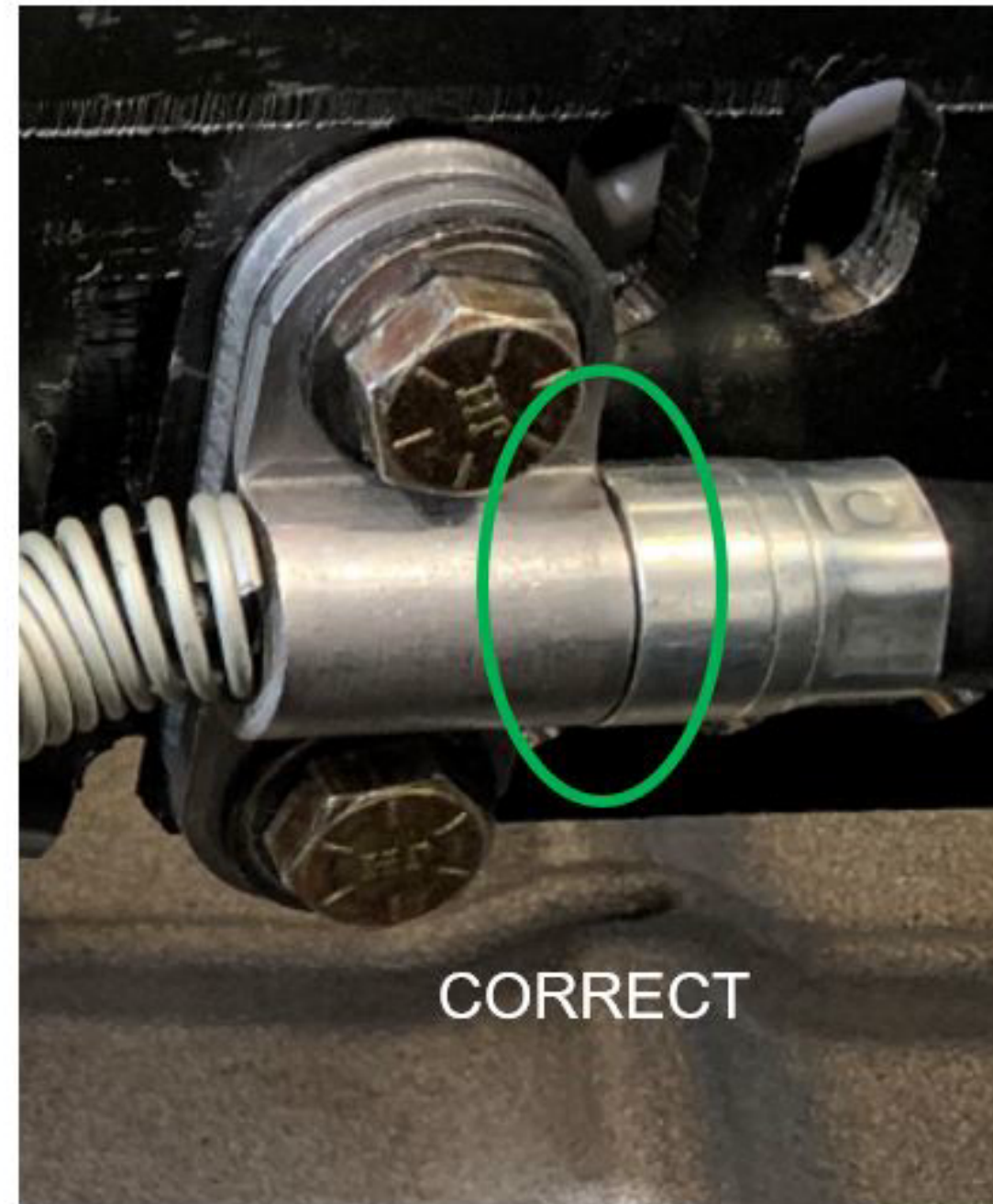
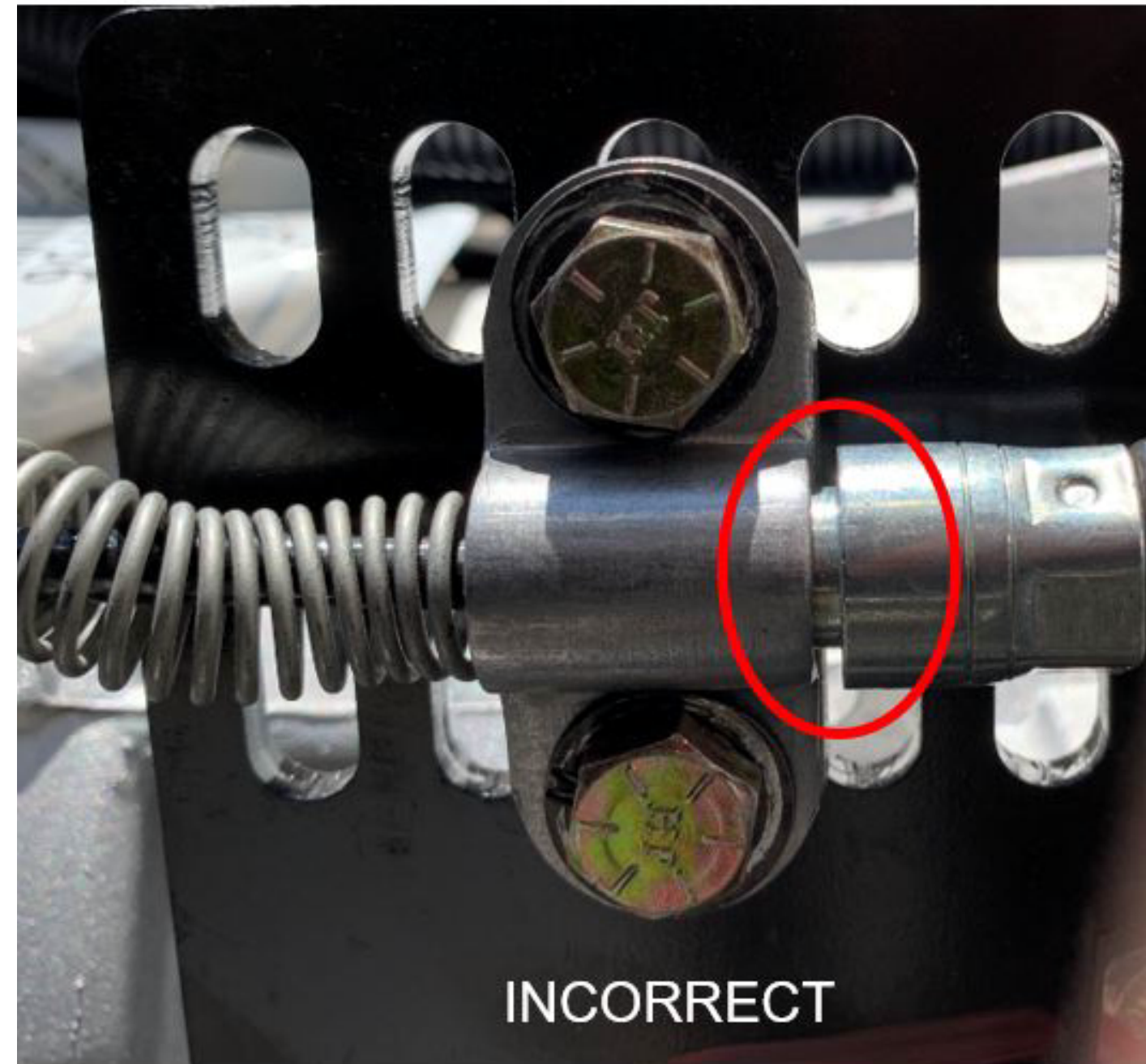

3. CHECK SLACK IN THE PARK BRAKE CABLE BY PULLING DOWN ON THE CABLE UNDER THE FOOT PEDAL.  
 A. ENSURE THAT THERE IS NO SLACK BY PULLING DOWN ON CABLE.  
 B. CHECK VISUALLY AND PHYSICALLY CHECK WITH YOUR FINGER TO ENSURE CABLE IS SEATED FLUSH ON THE BOTTOM OF THE PEDAL CLEVIS.

4. DO NOT SECURE THE CABLE TO THE BELL CRANK (ITEM #6) AT THIS POINT. REMOVE SLACK OUT OF BELL CRANK AND OTHER DOWNSTREAM LINKAGES BY PUSHING BELL CRANK FORWARD UNTIL YOU FEEL THE BRAKE SHOES CONTACT THE DRUM.



5. SCREW CABLE END YOKE (ITEM #10) FORWARD (CLOCKWISE) OR REARWARD(COUNTER-CLOCKWISE) SO THAT THE HOLE IN YOKE EYE ALIGNS WITH HOLE IN BELLCRANK. LOCK NUT MUST NOT BE TIGHTENED. DO NOT ENGAGE PARKING BRAKE BY PUSHING BELLCRANK TOO FAR FORWARD. PUSH BELL CRANK UNTIL INITIAL RESISTANCE IS FELT.



6. RE-ALIGN BELL CRANK AND YOKE. PLACE PIN (ITEM #88) INTO THE ALIGNED YOKE AND BELL CRANK AND SECURE WITH COTTER PIN (ITEM #16). TIGHTEN LOCK NUT (ITEM #89) AGAINST YOKE. **THE ASSEMBLY MUST MEET FMVSS 105.**

7. CENTER LINE OF CELVIS EYE TO CABLE END CLAMP SHOULD MEASURE  $8 \frac{3}{8}'' \pm \frac{1}{8}''$  IN RELEASED POSITION FOR FOOT PEDAL. HAND LEVER (F4004903) MEASUREMENT REMAINS  $7 \frac{3}{8}'' \pm \frac{1}{8}''$  IN RELEASED POSITION.

8. ENSURE THERE IS SUBSTANTIAL THREAD ENGAGEMENT BETWEEN THE CABLE AND CLEVIS. **MAXIMUM ALLOWABLE EXPOSED CABLE THREADS IS  $0.6875''$  ( $11/16''$ ).**



UTC 3/10/2022 7:38:24 AM

MATERIAL:		CONFIDENTIAL The information herein is confidential business information and may not be copied or used for any purpose unless permission is expressly granted in writing by Blue Bird Corporation. Copyright 2020 All Rights Reserved	
WEIGHT:	Project	Blue Bird Corporation	SCALE
FINISH (1)RAW (1)PRIME (1)PAINT (1)OTHER	B14261	Fort Valley, Georgia, U.S.A.	1/1
COLOR NAME			AA
SPEC #			AA
NOTES:	DIAGRAM:INSTL.PARK BRK,FORD PROPANE.CV		DR 11/25/10 BY ITL
TOLERANCE ON ALL DIMENSIONS IS PLUS (.00) OR MINUS (.00) (UNLESS OTHERWISE SPECIFIED)	DO SCALE	BY HH	E D0007365
INACTIVES NOS.			4/4