

November 23, 2022

Version 1

Safety Recall: 2017-19 Ridgeline Rearview Camera Inoperative Inspection

AFFECTED VEHICLES

Year	Model	Trim	VIN Range
2017-19	Ridgeline	ALL	Check the iN VIN status for eligibility.

BACKGROUND

The tailgate harness wires may become damaged with the articulation of the tailgate. This may cause the rearview camera to work intermittently or go blank.

CUSTOMER NOTIFICATION

Owners of affected vehicles will be sent a notification of this campaign.

Do an iN VIN status inquiry to make sure the vehicle is shown as eligible.

Some vehicles affected by this campaign may be in your new or used vehicle inventory.

Failure to repair a vehicle subject to a recall or campaign may subject your dealership to claims or lawsuits from the customer or anyone else harmed as a result of such failure. To see if a vehicle in inventory is affected by this safety recall, do a VIN status inquiry before selling it.

CORRECTIVE ACTION

Check the function of the back-up camera. If the camera is not working, inspect the rear tailgate harness. Replace the tailgate harness if harness damage is found.

NOTE: Only a replacement of the tailgate wiring harness will close the campaign, an inspection is to identify the system operation currently and to contact the customer once parts are available in ample supply.

CUSTOMER INFORMATION:The information in this bulletin is intended for use only by skilled technicians who have the proper tools, equipment, and training to correctly and safely maintain your vehicle. These procedures should not be attempted by "do-it-yourselfers," and you should not assume this bulletin applies to your vehicle, or that your vehicle has the condition described. To determine whether this information applies, contact an authorized Honda automobile dealer.

PARTS INFORMATION

NOTE:

- Tailgate harness supply availability will be very limited. Repair request is for a nonfunctioning camera only until parts inventory improves.
- If a harness replacement is required, please contact DPSM for approval.
- DPSM will require validation of non-functioning camera by visual inspection or photo.

Part Name	Order Part Number	You may receive any of the following	Quantity
2017–18 Tailgate Harness	32109-T6Z-A00	32109-T6Z-A00 32109-T6Z-305	1
2019 Tailgate Harness	32109-T6Z-A01	32109-T6Z-A01 32109-T6Z-A02	1

WARRANTY CLAIM INFORMATION

Operation Number	Description	Flat Rate Time	Defect Code	Symptom Code	Template ID	Failed Part Number
7375A5	Inspection only. Rear camera operation and tailgate wire harness.	0.3 hr	6RW00	KCK00	A22049A	32109-T6Z-A00
7371EV	Replace the tailgate harness (includes inspection).	1.2 hr	6RW00	KCK00	A22049B	32109-T6Z-A00

NOTE: You may receive one of two possible part numbers for 2017–18 model years and 2019 model year. Please add the part number to template ID A22049B.

INSPECTION PROCEDURE

1. Confirm operation of the rearview camera.
2. Turn the vehicle to accessory mode and put the transmission in reverse. With the help of an assistant, cycle the tailgate in drop down and swing mode.
 - If the camera is not working, go to step 3.
 - If the camera is working, inspection is complete. **No further action is needed, process an inspection warranty claim.**

3. Open the tailgate in drop-down mode. Inspect the harness at the left lower tailgate hinge area.
- If there is no damage to the harness wiring or corrugated tubing, continue with normal troubleshooting.
- If there is damage to the harness, go to REPAIR PROCEDURE.

NOTE: The tailgate harness supply availability will be very limited. If the harness replacement is required, please have your DPSM create a case with ACS. All part requests will require your DPSM to file a case with ACS for the part orders to be approved.



REPAIR PROCEDURE

1. Remove the wheel arch protectors.

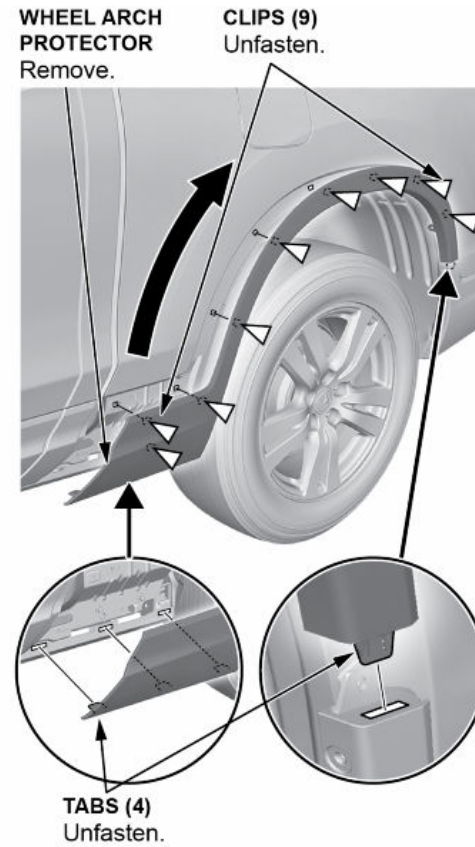
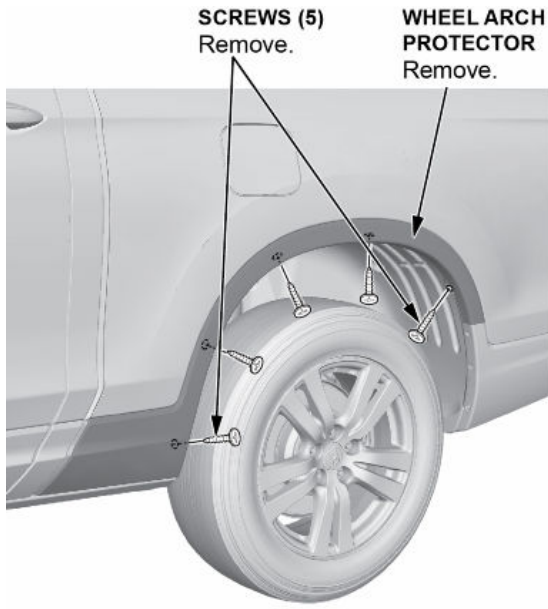

2. Remove rear splash guards (if equipped) 4 screws.

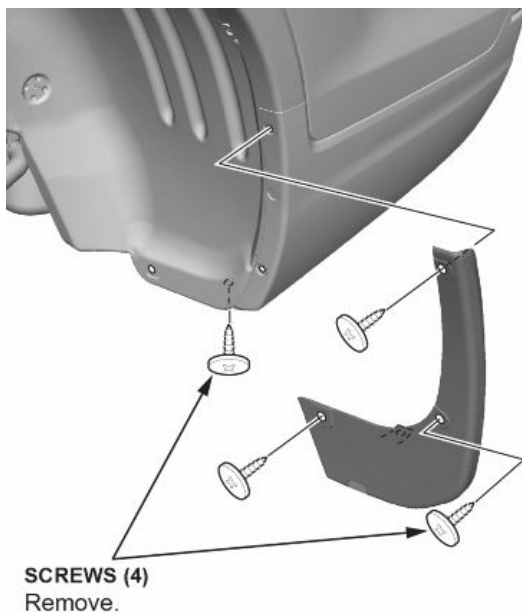

3. Remove the bolts, the screws, and the clips.

Without rear mud guard

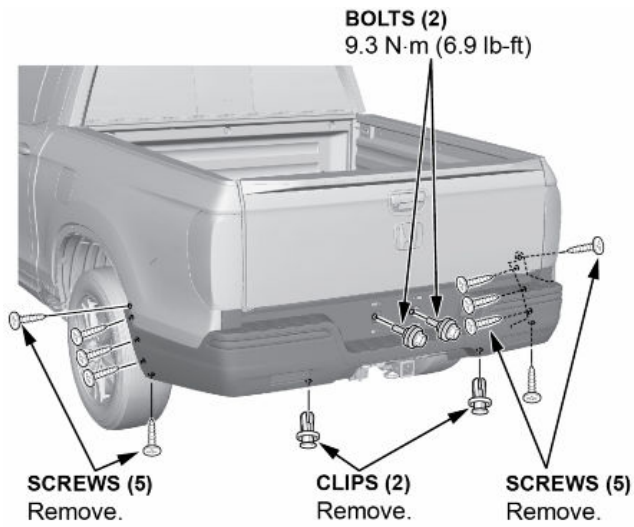

With rear mud guard

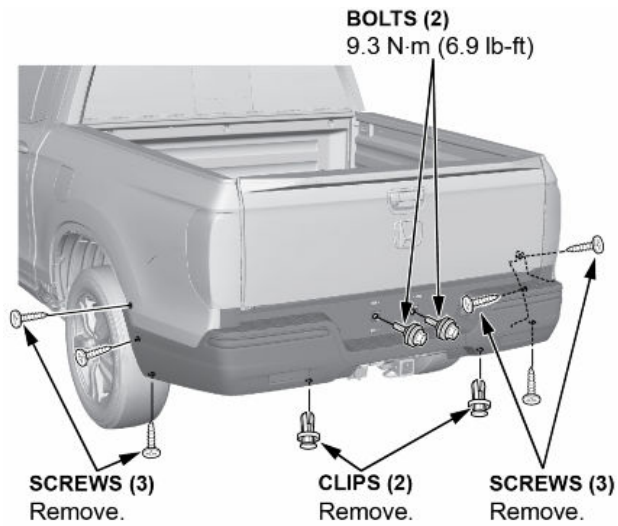

4. Pull out the rear bumper at the wheel arch area to release it from the hooks on the side spacer.

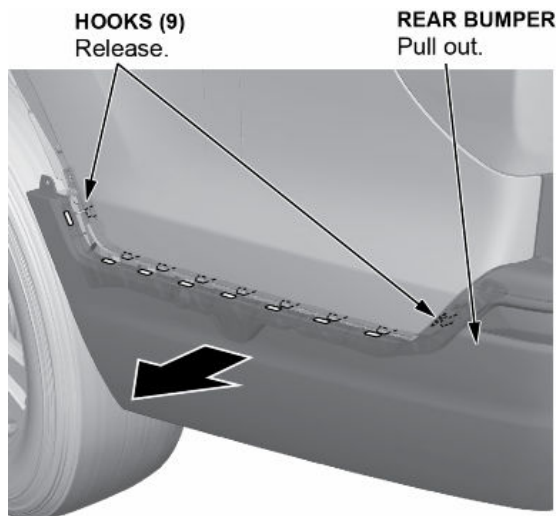

5. With the help of an assistant, release the rear bumper from the hooks on the spacer.

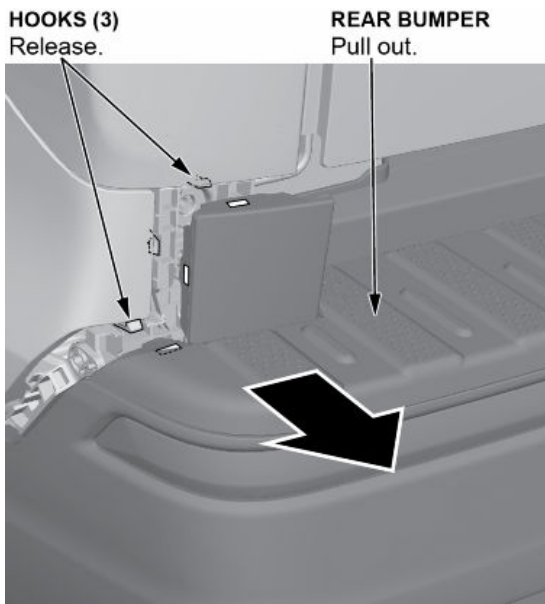

6. With the help of an assistant, pull out the rear bumper to release it from the hooks on the upper brackets. Disconnect the connectors (for some models). Remove the rear bumper.

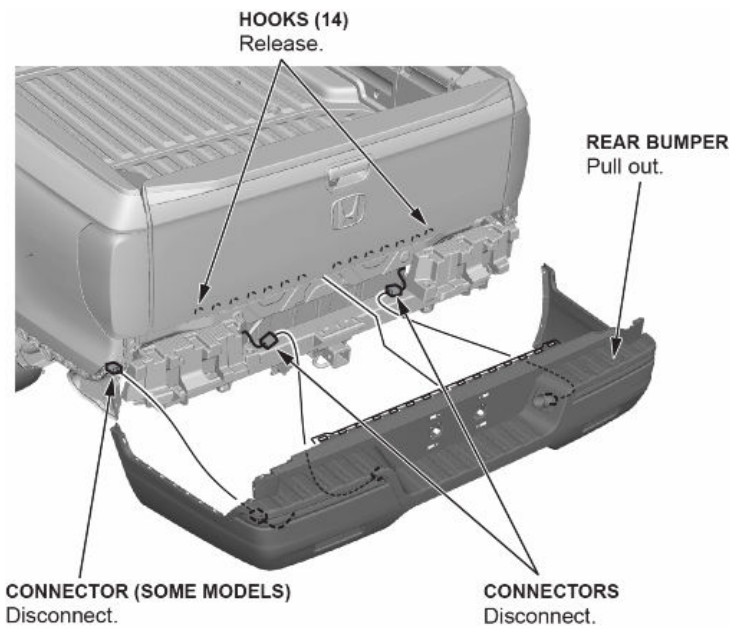

7. Remove the tailgate top trim.

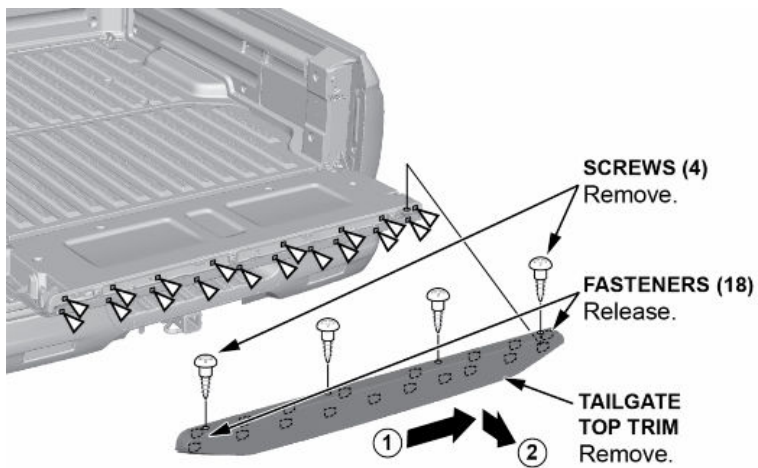

- Open the tailgate in drop-down mode.
- Remove the screws.
- Slide the tailgate top trim to the right, and remove it.
NOTE: The clips will stay in the tailgate.
- Remove the clips by turning them **45°**.

8. Remove the tailgate trim.

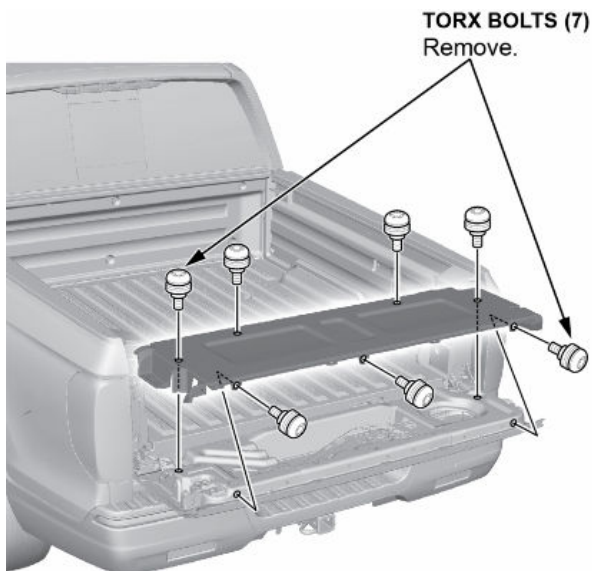

- Using a TORX T40 bit, remove the bolts, and then remove the tailgate trim.

9. Close the tailgate, disconnect the connector, and remove the harness clips.

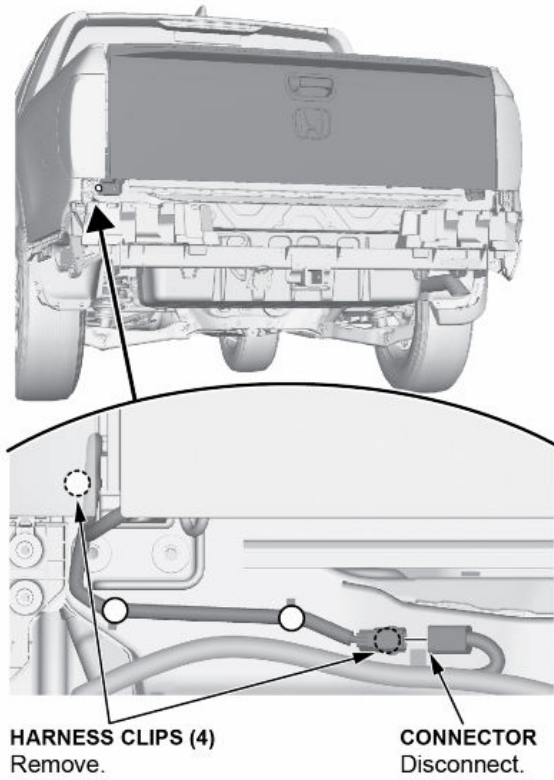

10. Open the tailgate in drop-down mode. Using a TORX T50 bit, loosen the left side tailgate lower hinge bolts but do not remove them entirely.



11. With the help of an assistant, lift the tailgate up slightly to allow clearance between the left tailgate lower hinge, and the tailgate for the harness to be removed.

NOTE: Be careful of pinch points when lifting the tailgate. Remove the tailgate harness, then remove the harness clips.

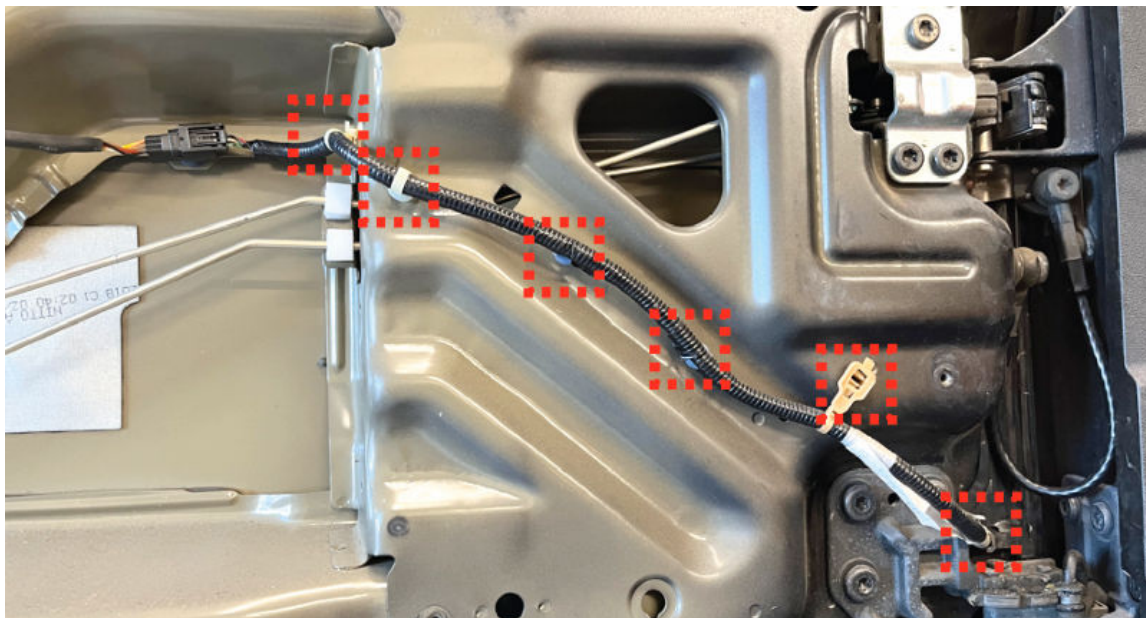

12. Disconnect the connector on the tailgate, then remove the harness clips.

13. Install the new harness. Make sure to route the new harness through the left tailgate hinge first.

NOTE:

- Be careful to attach the clip on the edge of the square notch on the tailgate first, and then attach the clip.
- **Annotate the replacement part number on the RO.**

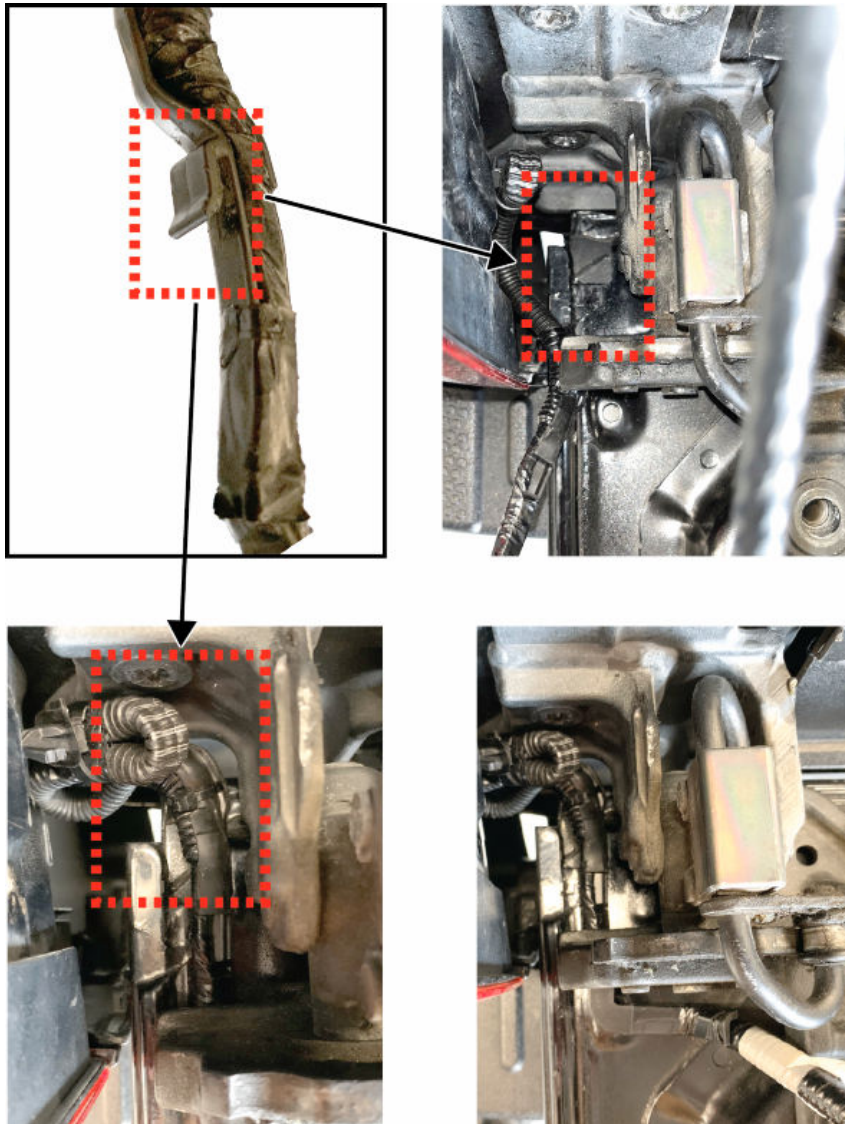

14. Route the harness along the tailgate and hinge and attach the clips. Connect the connector.

15. Torque the three Torx bolts to the lower left tailgate hinge to **41 N.m (30 lb-ft)**.

16. Install all of the parts in the reverse order of removal.

END