

## Awning Fabric Weld Repair Instructions

<b>Bulletin Type:</b>	Recall	<b>Publication Date:</b>	August 2022
<b>Bulletin #(s):</b>	22V-571 US 2022-424 Canada	<b>Revision Date:</b>	September 2022
<b>Job Code(s):</b>	9901578	<b>Revision Date:</b>	December 2022
<b>Flat Rate(s):</b>	9901578A - 0.30 Inspection only 9901578B - 0.60 Inspection and Repair 9901578C - 1.8 Inspection and Replace	<b>Make(s):</b>	Jayco
		<b>Model(s):</b>	Eagle, Jay Flight, North Point, Pinnacle, Seismic
		<b>Model Year(s):</b>	2022-2023
<b>Incident:</b>	Insufficient Fabric Awning Weld		
<b>Affected Units:</b>	2022-2023 Jayco Eagle, Jay Flight, North Point, Pinnacle, Seismic		
<b>Parts Kit: 22V-571</b>	Parts Kit #: 22V-571		
	Part Kit Contents: Adhesive, RPR Seam Awning (Jayco Part #2040196)		
<b>Misc. Tools &amp; Supplies: N/A</b>	<b>Stepladder</b>		

## Awning Fabric Weld Repair Instructions

<b>Bulletin Type:</b>	Recall	<b>Publication Date:</b>	August 2022
<b>Bulletin #(s):</b>	22V-572 US 2022-425 Canada	<b>Revision Date:</b>	September 2022
<b>Job Code(s):</b>	9902578	<b>Revision Date:</b>	December 2022
<b>Flat Rate(s):</b>	9901578A - 0.30 Inspection only 9901578B - 0.60 Inspection and Repair 9901578C - 1.8 Inspection and Replace	<b>Make(s):</b>	Starcraft
		<b>Model(s):</b>	Autumn Ridge Outfitter, Super Lite Maxx, Super Lite
		<b>Model Year(s):</b>	2022
<b>Incident:</b>	Insufficient Fabric Awning Weld		
<b>Affected Units:</b>	2022 Starcraft Autumn Ridge Outfitter, Super Lite Maxx, Super Lite		
<b>Parts Kit: 22V-571</b>	Parts Kit #: 22V-571		
	Part Kit Contents: Adhesive, RPR Seam Awning (Jayco Part #2040196)		
<b>Misc. Tools &amp; Supplies: N/A</b>	<b>Stepladder</b>		

## Awning Fabric Weld Repair Instructions

<b>Bulletin Type:</b>	Recall	<b>Publication Date:</b>	August 2022
<b>Bulletin #(s):</b>	22V-575 US 2022-426 Canada	<b>Revision Date:</b>	September 2022
<b>Job Code(s):</b>	9903578	<b>Revision Date:</b>	December 2022
<b>Flat Rate(s):</b>	9901578A - 0.30 Inspection only 9901578B - 0.60 Inspection and Repair 9901578C - 1.8 Inspection and Replace	<b>Make(s):</b>	Jayco & Entegra Coach
		<b>Model(s):</b>	Greyhawk, Melbourne, Redhawk, Odyssey
		<b>Model Year(s):</b>	2022

<b>Incident:</b>	Insufficient Fabric Awning Weld
<b>Affected Units:</b>	2022 Jayco Greyhawk, Melbourne, Redhawk & Entegra Coach Odyssey
<b>Parts Kit: 22V-571</b>	Parts Kit #: 22V-571
	Part Kit Contents: Adhesive, RPR Seam Awning (Jayco Part #2040196)
<b>Misc. Tools &amp; Supplies:</b>	Stepladder

## Awning Fabric Weld Repair Instructions

<b>Bulletin Type:</b>	Recall	<b>Publication Date:</b>	August 2022
<b>Bulletin #(s):</b>	22V-573 US 2022-427 Canada	<b>Revision Date:</b>	September 2022
<b>Job Code(s):</b>	9904578	<b>Revision Date:</b>	December 2022
<b>Flat Rate(s):</b>	9901578A - 0.30 Inspection only 9901578B - 0.60 Inspection and Repair 9901578C - 1.8 Inspection and Replace	<b>Make(s):</b>	Highland Ridge
		<b>Model(s):</b>	Mesa Ridge, Olympia, Open Range, Range Lite, Silverstar
		<b>Model Year(s):</b>	2022

<b>Incident:</b>	Insufficient Fabric Awning Weld
<b>Affected Units:</b>	2022 Highland Ridge Mesa Ridge, Olympia, Open Range, Range Lite, Silverstar
<b>Parts Kit: 22V-571</b>	Parts Kit #: 22V-571
	Part Kit Contents: Adhesive, RPR Seam Awning (Jayco Part #2040196)
<b>Misc. Tools &amp; Supplies:</b>	Stepladder

## INSUFFICIENT AWNING WELD(S) INSPECTION

- **Note:** This document supersedes the previously released version dated August 2022.
  - **Resourced Required:** Stepladder of adequate height to perform push test and inspect weld near awning rail.
1. All repairs must be documented with the following information:
    - a. Full unit information, including 17 digit VIN, Make/Model/Floorplan and Date of Manufacture.
    - b. Clear photo of the awning tag.
    - c. Photos documenting any weld separation concerns.
  2. This recall only affects awnings manufactured between January 17, 2022 - June 14, 2022. The date of manufacture can be located on the variant code label located on the awning fabric. (Figure 1) File for inspection only if the date range is outside January 17, 2022 - June 14, 2022. Proceed with inspection instructions of awning fabric weld if date range is between January 17, 2022 - June 14, 2022.
  3. Perform push test:
    - a. Extend the awning.
    - b. From underneath the awning, about 1" to 1.5" from the fabric edge push up on the fabric with one finger (Object 1) until the awning fabric is flush with the top of the awning rail. Look for any separation or visible daylight at the seam. Perform push test at both ends of the awning.
  4. Figure 2 shows no separation at the seam. File a claim for inspection only.
  5. Figure 3 shows separation at the seam:
    - a. If the separation is less than 6 inches, repair can be accomplished using the procedures described in the INSUFFICIENT AWNING FABRIC WELD REPAIR INSTRUCTIONS.
    - b. If the separation is over 6 inches, it will require the INSUFFICIENT AWNING FABRIC WELD REPLACEMENT INSTRUCTIONS.

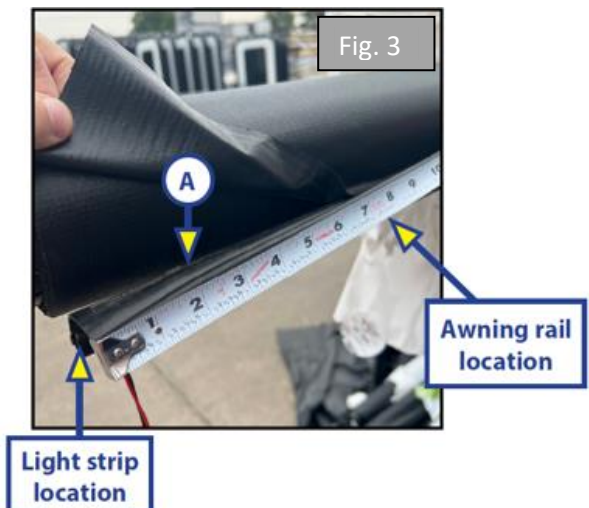
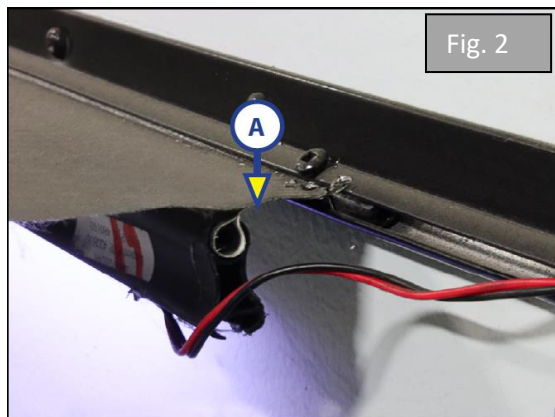
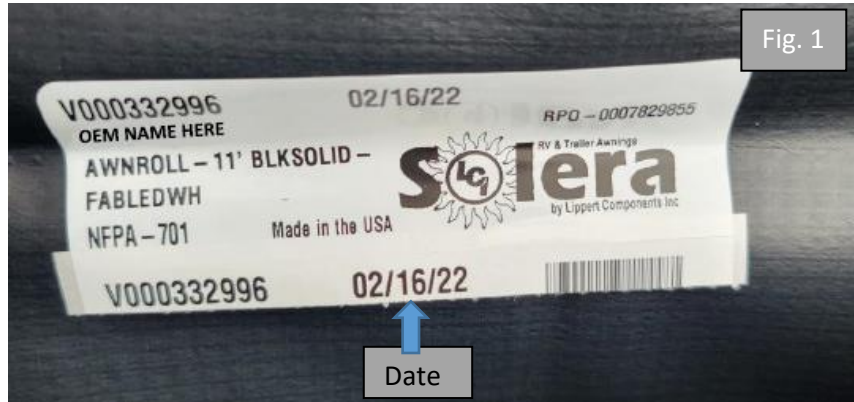

## INSUFFICIENT AWNING FABRIC WELD REPAIR INSTRUCTIONS

- **Seam Separation Repair Procedure is below**
- **Note: The repair procedure is optimal for seam separation less than 6".**
- Resources Required: Awning Seam Repair Adhesive Parts Kit #: 22V-571 (Figure 4)
  1. Begin by extending the awning:
    - a. For a seam fix at the awning rail, extend the awning a few feet.
  2. Tie both awning arms slightly back to gain some slack at the fabric.
  3. Clean the area to be repaired with mild soap and water. Allow to dry completely.
  4. Spread open the seam area needing repair (Figure 5) and apply a continuous bead of Awning Seam Repair Adhesive. (Figure 6)
    - a. Note: Figure 5 shows fabric off awning for clarity and upside down. The repair can be completed with the awning fabric installed.
  5. Use Awning Seam Repair Adhesive Parts Kit #: 22V-571 (Figure 4) along the entire separation (Figure 6).
  6. Press down firmly and hold for several minutes.
  7. Allow to dry for at least four hours.



Fig. 4

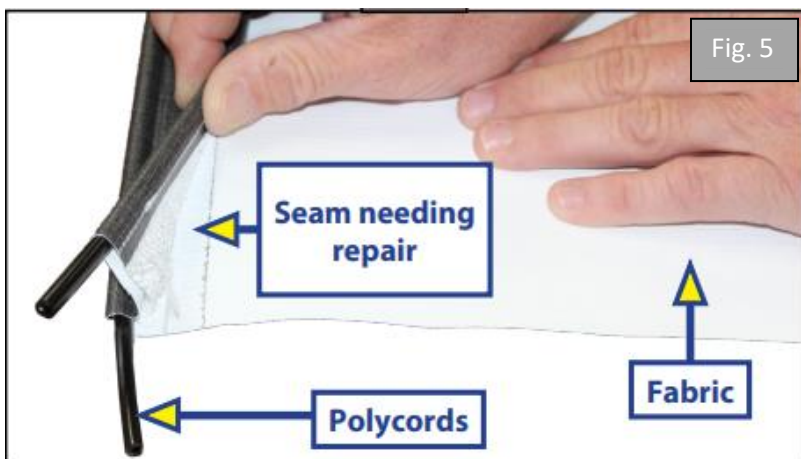

Fig. 5



Fig. 6

## INSUFFICIENT AWNING FABRIC WELD REPLACEMENT INSTRUCTIONS

- **CAUTION: Moving parts can pinch, crush or cut. Keep clear and use caution.**
- **Note: Previous awning versions had two (2) polycords and fabric stitching along the hem. The current awning model has one (1) polycord (see Figure 7) and no fabric stitching. This should not be mistaken as defective.**
- **Manual Awning Fabric Replacement**
  1. Order the Awning Fabric using the Compliance Order Form. You must include with order form:
    - a. Clear photo of the awning tag.
    - b. Photos documenting any weld separation concerns.
  2. Remove the drip cap (if equipped) from the end of the awning from which the fabric will be removed.
  3. Extend the awning out approximately 12" and insert cotter pins through both end caps into the shafts on the head assemblies. (Figure 8)

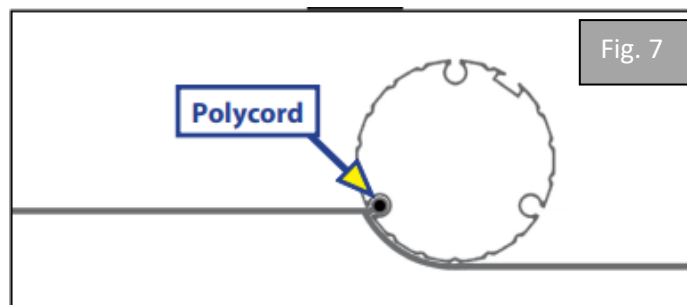

Fig. 7



Fig. 8

- a. Note: If the awning is 6' in length it will only need one cotter pin for the drive side end cap.
4. Secure both support arm assemblies by running a zip tie around the outer arm and around the pin on the top of the mount arm where the mount arm and inner arm connect. (Figure 9)
5. Remove the screws holding the poly cord in place on the awning rail.
  - a. **WARNING:** If not properly secured, the support arms can kick out due to pressure from the gas strut, which may result in serious injury or property damage.
6. Remove the drive head assembly and idler head assembly retaining bolts from the outer arms to separate the components.
7. Working together, remove the roll tube assembly (which includes the drive/idler head assemblies) from the awning rail and support arms by sliding the assembly along the awning rail until clear.
8. Secure the idler head and the roll tube to a work bench. Failure to support the roll tube, fabric and drive/idler head assemblies during removal may result in serious injury or property damage.
9. Hold the drive head assembly securely (there will be tension to be released) while another person removes the drive head assembly cotter pin.
10. While one person holds the roll tube, have another person slowly rotate the drive head assembly clockwise to release tension.
11. Mark the cam lock position on the roll tube with a non-permanent marker.
12. Remove the three screws holding the drive head assembly end cap on the roll tube and set the drive head assembly aside:
  - a. Note: Awnings longer than 6' will also have tension that needs to be released in the idler head assembly prior to continuing the procedure. To release tension, remove the idler head cotter pin and slowly rotate the idler head in a counterclockwise motion to release tension in the idler head assembly's spring.
13. Place the roll tube and fabric on a clean, level surface that is free of any debris able to scratch or damage the roll tube and/or fabric.
14. With one person holding the awning rail end of the fabric, another can rotate the roll tube to unroll the fabric until only the poly cord is left on the roll tube.
15. Remove the screws holding the poly cord in place on the roll tube.
16. Mark the roll tube groove containing the poly cord with a non-permanent marker prior to removing the fabric from the roll tube.
17. To remove the fabric, gently pull the roll tube from the idler end, while another person holds the fabric in place.



### • **Awning Fabric Installation**

1. Unroll the replacement fabric printed side down so that the polycord is parallel and away from the roll tube.
2. On a clean, level surface free of any debris able to scratch or damage the roll tube, gently slide the roll tube onto the polycord of the fabric, making sure that the non-printed side is touching the roll tube. (Figure 10)
3. Center the fabric on the roll tube.
4. Apply the screws that were holding the polycord in place on the roll tube. Install the screws no more than 1" from the edge of the fabric.
5. Roll the fabric onto the roll tube (Figure 11). Make sure the fabric stays snug and flat to the roll tube with the printed side facing away.
6. Using the three screws previously removed from the drive head assembly end cap, attach the drive head to the roll tube, making sure the orientation is the same.



- a. Note: Be sure the drive head assembly with the cam lock is on the right-hand side of the awning.

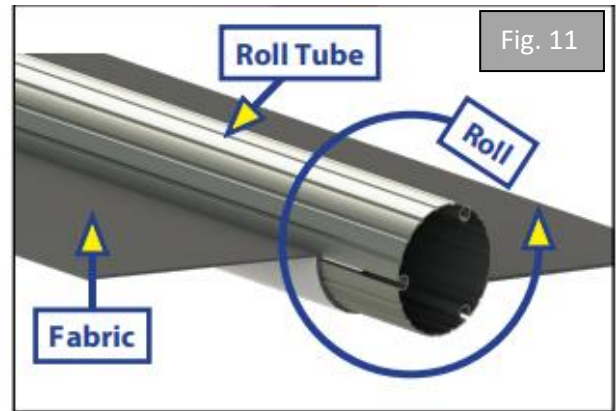
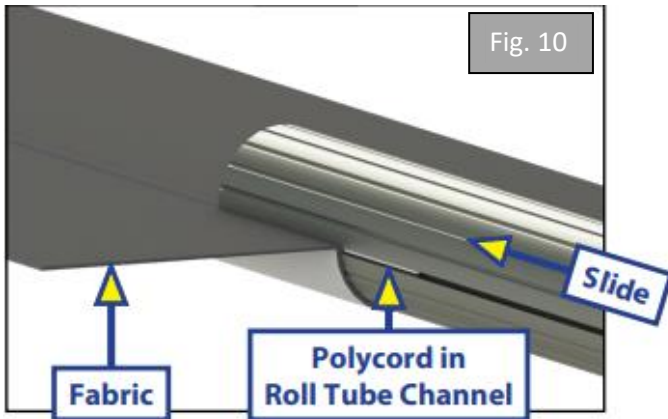

7. Secure the idler head and roll tube to the work bench.
8. Rotate the drive head assembly counterclockwise, proper turns according to the length of the awning (Figure 12) and insert a cotter pin into the end cap into the shaft on the drive head assembly:

Manual Awning Tensioning	
Awning Length	Proper Tensioning (# of turns)
6'	15
7'-16'	9
17'-21'	10
22'-28'	11

**NOTE: \*6' Awnings only have one spring to tension on the drive side.**

- a. **Note: Failure to support the roll tube, fabric and drive/idler head assembly during installation may result in serious injury or property damage.**
- b. **Note: If the awning is longer than 6' and the idler head assembly tension had previously been released, rotate the idler head assembly clockwise according to the length of the awning (Fig. 6) and insert a cotter pin into the end cap into the shaft on the idler head assembly. Be sure that both head assemblies are parallel once tension has been added.**
9. Working together, install the roll tube assembly (which includes the drive/idler head assemblies) to the awning rail and support arms by sliding the assembly along the awning rail. Make sure the awning will unroll with the printed side of the fabric up.
10. Install the previously removed drive/idler head assembly retaining bolts into the outer arms to secure.
11. Remove the cotter pins from both end caps and cut the zip ties from the support arm assemblies.
12. Extend and retract the awning several times to ensure that the fabric is square on the roll tube.
13. Secure the fabric in the awning rail 1" inside the edge of the fabric on both ends using a #6 x 1/2" hex head screw. Install the screw down through the awning rail into the fabric and the polycord (Figure 13).
14. Reinstall the drip cap (if previously equipped).

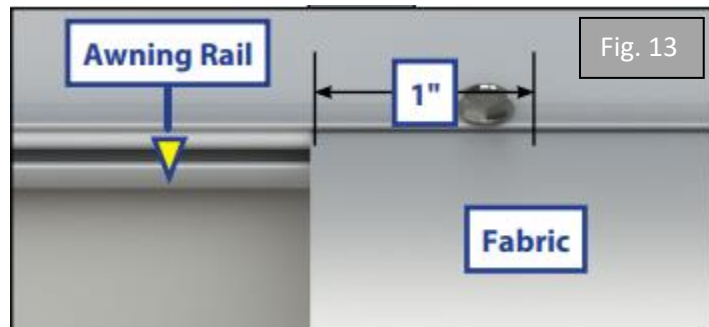

## • Power and Hybrid Awning Fabric Replacement

1. Remove the drip cap (if equipped) from the end from which the fabric will be removed.
2. Fully extend the awning.
3. Disconnect any fabric LED lights in the support arm assembly or remove the fabric LED light strip from the poly cord of the fabric.
4. Retract the awning until approximately 12" remain visible.
5. Secure both support arm assemblies by running a zip tie around the outer arm and around the pin on the top of the mount arm where the mount arm and inner arm connect. (Figure 14)
6. Remove the screws holding the poly cord in place on the awning rail.
7. Remove the wax screws holding the end caps onto the drive and idler head shafts (Figure 15).
8. Working together, remove the roll tube and fabric from the awning rail and support arm assemblies.
9. Place the roll tube and fabric on a clean, level surface that is free of any debris able to scratch or damage the roll tube and/or fabric
  - a. **WARNING:** Failure to support the roll tube, fabric and drive/idler head assembly during installation may result in serious injury or property damage.
10. Remove the end cap from the end of the roll tube from which the fabric will be removed.
11. With one person holding the end of the fabric that gets attached to the awning rail on the unit, another can rotate the roll tube to unroll the fabric until only the polycord is left on the roll tube.
12. Remove the screws holding the polycord in place on the roll tube.
13. To remove the fabric, gently pull the roll tube from one end, while another person holds the fabric in place.



Fig. 14



Fig. 15

## • Installation

1. Unroll the replacement fabric so that the cords are parallel with the roll tube.
2. On a clean, level surface free of any debris able to scratch or damage the roll tube, gently slide the roll tube onto the polycord of the fabric, making sure that the non-printed side is touching the roll tube (Figure 16).
3. Center the fabric on the roll tube.
4. Install the screws that were holding the polycord in place on the roll tube. Install the screws no more than 1" from the edge of the fabric.
5. Roll the fabric onto the roll tube (Figure 17). Make sure the fabric stays snug and flat to the roll tube with the printed side facing away.

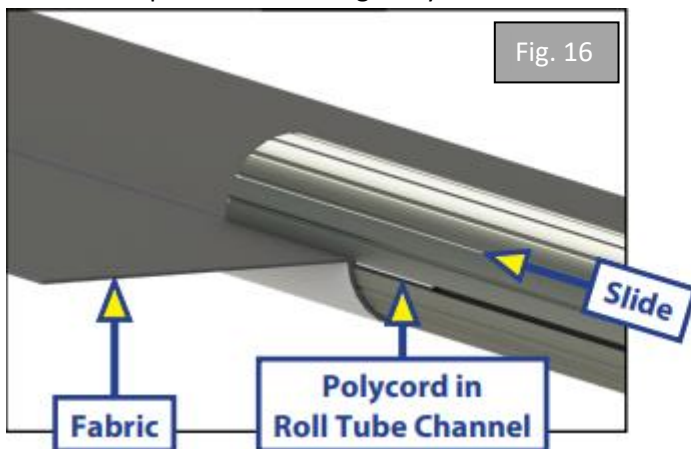

Fig. 16

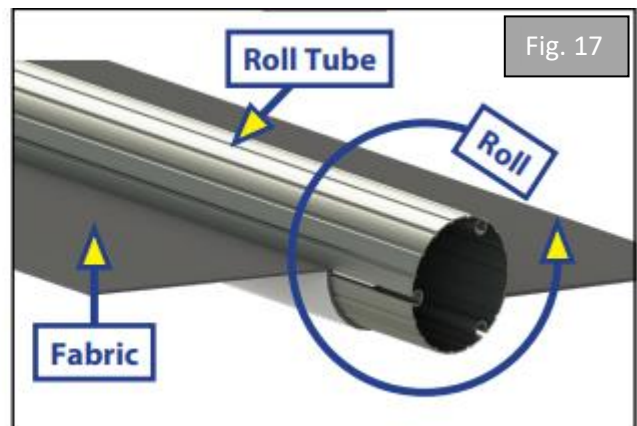
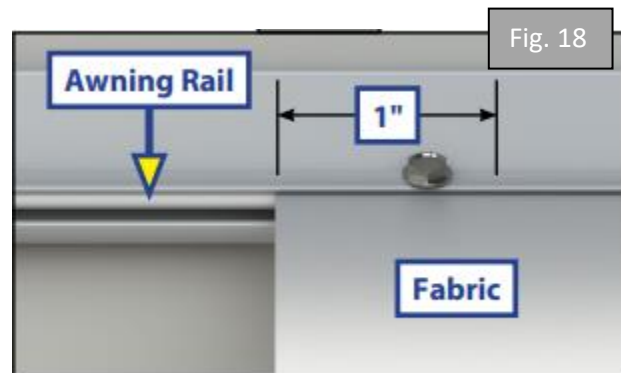

Fig. 17

6. Reinstall the end cap previously removed.
7. Working together, install the roll tube and fabric on the awning rail and support arms, making sure the awning will unroll with the printed side of the fabric up.
  - a. **WARNING:** Failure to support the roll tube, fabric and drive/idler head assembly during installation may result in serious injury or property damage.
8. Working together, slide the shaft on the head assembly into the end cap. Install the wax screws at each end to secure the roll tube end caps to the head assemblies.
  - a. Note: It is suggested to keep the head of the wax screw 1/8" from fastened so as not to compromise the structural integrity of the wax screw.
9. Extend and retract the awning several times to ensure that the fabric is square on the roll tube.
10. Secure the fabric in the awning rail no more than 1" inside the edge of the fabric on both ends using a #6 x 1/2" hex head screw. Install the screw down through the awning rail into the fabric and the polycord. (Figure 18)
11. Reinstall the drip cap (if previously equipped).
12. Reconnect any light wiring as needed.
  - a. Note: The fabric LED light strip will need to be installed on the polycord of the fabric prior to connecting any wiring previously removed.



*Jayco's sole obligation under our limited warranty is to repair or replace defective materials and/or workmanship deemed our responsibility as determined by Jayco in our sole discretion. Jayco reserves the right to use new and/or remanufactured parts or materials of similar quality to complete any work, and to make parts and/or design changes as appropriate without notice to anyone. Jayco designs and/or materials changes are done without obligation to incorporate such changes in previously manufactured product. Jayco makes every reasonable effort to ensure field remedies will not adversely affect performance and/or safety of the unit. This field remedy is not intended to extend to future performance of this RV, or any of its materials, components or parts beyond the standard warranty period. The RV owner's obligation to notify Jayco, or one of its independent, authorized dealers, of a claimed defect does not modify any obligation placed on the RV owner to contact Jayco directly when attempting to pursue remedies under state or federal law.*

903 South Main Street • P.O. Box 460 • Middlebury, IN 46540