



SAFETY RELATED RECALL

Global Recall Action
Number: H412

Subject: Autoliv Seatbelt Retractor Functionality	Publication No.: H412
	Model: F-PACE (X761)
	Model Year: 2022 - 2023
	Model: F-TYPE (X152)
	Model Year: 2022
	Model: XF (X260)
	Model Year: 2022
	Date of Issue: 19 August 2022

To:	Jaguar Land Rover (JLR) North America, LLC - USA and Canada
For the Attention of:	The approved JLR retailer/authorized repairer
Important:	NOTE: The information in this campaign is intended for use by trained, professional technicians with the knowledge, tools, and equipment required to do the job properly and safely. It informs these technicians of conditions that may occur on some vehicles or provides information that could assist in proper vehicle service. The procedures should not be performed by 'do-it-yourselfers'. If you are not a JLR retailer/authorized repairer, do not assume that a condition described affects your vehicle. Contact an authorized JLR retailer/authorized repairer to determine if this campaign applies to a specific vehicle

DESCRIPTION OF ISSUE AND THE EFFECT ON VEHICLE OPERATION

A potential concern has been identified on specific vehicles within the above vehicle range.

A concern has been identified on certain 2022 model year F-TYPE, XE and XF vehicles and certain 2022 and 2023 model year F-PACE vehicles where a damaged front seatbelt pretensioner tube may have been installed on the seatbelt retractor. The damaged tube could prevent the pretensioner from correctly operating by not pre-tensioning the seatbelt in the event of an accident where it would normally operate. This may result in a reduced level or complete loss of pre-tensioning in the event of a crash and increased occupant injury.

REGULATORY INFORMATION

JLR North America, LLC and JLR Canada ULC have informed the National Highway Traffic Safety Administration (NHTSA) and Transport Canada (TC) of their intent to perform a Safety Recall on certain 2022 model year F-TYPE, XE and XF vehicles and certain 2022 and 2023 model year F-PACE vehicles imported into the United States and Canadian markets. Information relating to this Safety Recall will be posted on the NHTSA and TC websites. United States Federal regulations require that retailers/authorized repairers must be notified within a reasonable time after the manufacturer decides that a defect that relates to motor vehicle safety or a non-compliance exists. United States Federal Law requires retailers/authorized repairers to complete any outstanding Safety Recall before a new vehicle is delivered to the buyer or lessee. Violation of this requirement by a retailer/authorized repairer, in the USA only, could result in a maximum civil penalty of up to the equivalent of \$24,423.00 USD per violation and the equivalent of \$122,106,996.00 USD for a related series of violations. This Safety Recall serves as notification to all retailers/authorized repairers in the United States and Federalized Territories and Canada that any affected new vehicles may not be sold and delivered for customer use until the Safety Recall repair is completed.

JLR North America, LLC / JLR Canada ULC recommends that affected sales demonstrator and loaner vehicles are repaired before use, and that used vehicles are repaired before sale. Retailers/authorized repairers who choose to proceed against this recommendation, where legally permitted, must clearly and conspicuously disclose the open Safety Recall notice to the applicable customers.

ACTION TO BE TAKEN

JLR has taken the decision to recall affected vehicles to repair the vehicle.

Visit the British Brands Sales Suite (BBSS) website for a list of affected vehicles at your retailer/authorized repairer.

Following procedures appropriate to your market and as required by local legislation, owners of affected vehicles should be contacted requesting that the owner contact their nearest retailer/authorized repairer as soon as possible to arrange for the repair to be completed. The National Sales Companies (NSCs), Importer, Regional Office or Government agency will contact the customers. If you have any questions about this process, please contact your NSC/Importer or Regional Office for more information.

Check the JLR Warranty Portal to make sure affected vehicles are correctly identified prior to starting this campaign. The Warranty Portal will be updated to reflect only those vehicles affected.

Retailers/authorized repairers are reminded that they must not sell vehicles identified as affected by this campaign until such time as the repair has been successfully completed.

An owner may indicate that a repair has already been completed for this concern, in which case the full cost of the repair should be reimbursed. Refer to the warranty section of this campaign for details of the Customer Reimbursement and Related Damage Process. At the time of confirming a booking for a vehicle repair, make sure you check the Warranty Portal to confirm if there are any other outstanding campaigns, to make sure the correct parts are available and adequate workshop time is allocated for repairs to be completed in one visit.

For information purposes, a Technical Question and Answer document is attached.

Yours faithfully

Steve Oldham

Global Customer Service Quality Director

SERVICE INSTRUCTION - H412



NOTE: The information in this campaign is intended for use by trained, professional technicians with the knowledge, tools, and equipment required to do the job properly and safely. It informs these technicians of conditions that may occur on some vehicles or provides information that could assist in proper vehicle service. The procedures should not be performed by 'do-it-yourselfers'. If you are not a Jaguar Land Rover (JLR) retailer/authorized repairer, do not assume that a condition described affects your vehicle. Contact an authorized [JLR](#) retailer/authorized repairer to determine if this campaign applies to a specific vehicle

Parts Information

Any required parts should be ordered through [JLR](#) in the normal manner, however, for this campaign, parts should be claimed for using the Customer Reimbursement and Related Damage Process - See the Customer Reimbursement and Related Damage Process section below for further details.

SROs - XF vehicles

Description	Model	SRO	Time
Front seatbelt retractors - Inspect pair - No further action	XF	05.10.50	0.5
Front seatbelt retractors - Inspect pair - Renew single	XF	05.10.70	0.7
Front seatbelt retractors - Inspect pair - Renew pair	XF	05.10.80	0.8
Drive in/drive out	XF	10.10.10	0.2



NOTE: Repair procedures are under constant review, and therefore times are subject to change; those quoted here must be taken as guidance only. Always refer to TOPIx to obtain the latest repair time.

SROs - XE vehicles

Description	Model	SRO	Time
Front seatbelt retractors - Inspect pair - No further action	XE	05.10.40	0.4
Front seatbelt retractors - Inspect pair - Renew single	XE	05.10.60	0.6
Front seatbelt retractors - Inspect pair - Renew pair	XE	05.10.70	0.7
Drive in/drive out	XE	10.10.10	0.2



NOTE: Repair procedures are under constant review, and therefore times are subject to change; those quoted here must be taken as guidance only. Always refer to TOPIx to obtain the latest repair time.

SROs - F-PACE vehicles

Description	Model	SRO	Time
Front seatbelt retractors - Inspect pair - No further action	F-PACE	05.10.50	0.5
Front seatbelt retractors - Inspect pair - Renew single	F-PACE	05.10.70	0.7
Front seatbelt retractors - Inspect pair - Renew pair	F-PACE	05.10.80	0.8
Drive in/drive out	F-PACE	10.10.10	0.2



NOTE: Repair procedures are under constant review, and therefore times are subject to change; those quoted here must be taken as guidance only. Always refer to TOPIx to obtain the latest repair time.

SROs - F-TYPE vehicles

Description	Model	SRO	Time
-------------	-------	-----	------

Description	Model	SRO	Time
Front seatbelt retractors - Inspect pair - No further action	F-TYPE	05.10.50	0.5
Front seatbelt retractors - Inspect pair - Renew single	F-TYPE	05.10.60	0.6
Front seatbelt retractors - Inspect pair - Renew pair	F-TYPE	05.10.70	0.7
Drive in/drive out	F-TYPE	10.10.10	0.2



NOTE: Repair procedures are under constant review, and therefore times are subject to change; those quoted here must be taken as guidance only. Always refer to TOPlx to obtain the latest repair time.

Warranty Information

Warranty claims should be submitted quoting program code H412 with option code X. In this instance it will also be necessary to enter the relevant SROs from the warranty information table.

The option that allows for the drive in/drive out allowance can only be claimed if the vehicle is brought back into the workshop for this action alone to be undertaken.

Warranty claims should be submitted in accordance with the current JLR Warranty Manual and its amendments, unless stated otherwise in this bulletin.

Customer Reimbursement and Related Damage Process



NOTE: If there is a requirement to claim for related/consequential damage or customer reimbursement, refer to the related instruction that can be found in TOPlx (in the Search box search for 'Related Damage Claim' and open the related bulletin link).

Table of Contents
REMOVAL AND INSTALLATION: SERVICE INSTRUCTION 1 - XF VEHICLES
REMOVAL AND INSTALLATION: SERVICE INSTRUCTION 2 - XE VEHICLES
REMOVAL AND INSTALLATION: SERVICE INSTRUCTION 3 - F-PACE VEHICLES
REMOVAL AND INSTALLATION: SERVICE INSTRUCTION 4 - F-TYPE VEHICLES

SERVICE INSTRUCTION 1 - XF VEHICLES

NOTES:



Some illustrations may vary depending on the vehicle specification but the essential information is always correct.



Some components are shown removed from the vehicle to provide extra clarity.



Front safety belt retractor is also known as front row seatbelt retractor in the TOPlx Workshop Manual.

1. Position the front row seat to the most forward position.

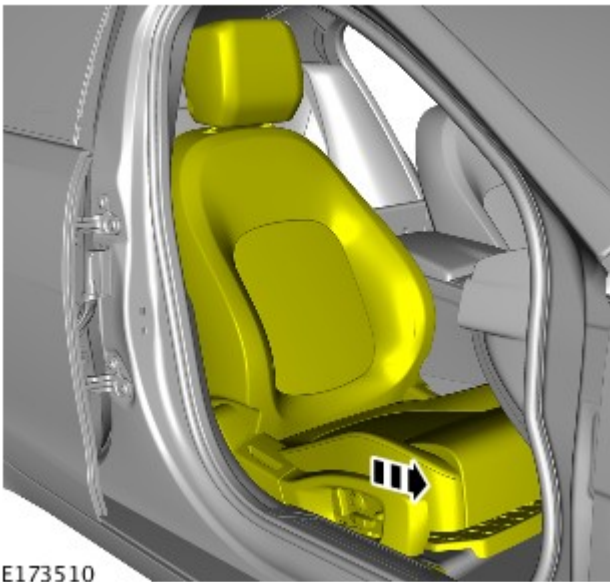

E173510

2. Release the 2 door aperture seals.



E173508

3. Release, but do not fully remove the b-pillar upper trim panel.

1. Release the 2 lower trim clips.

2. Release the 2 center clips.

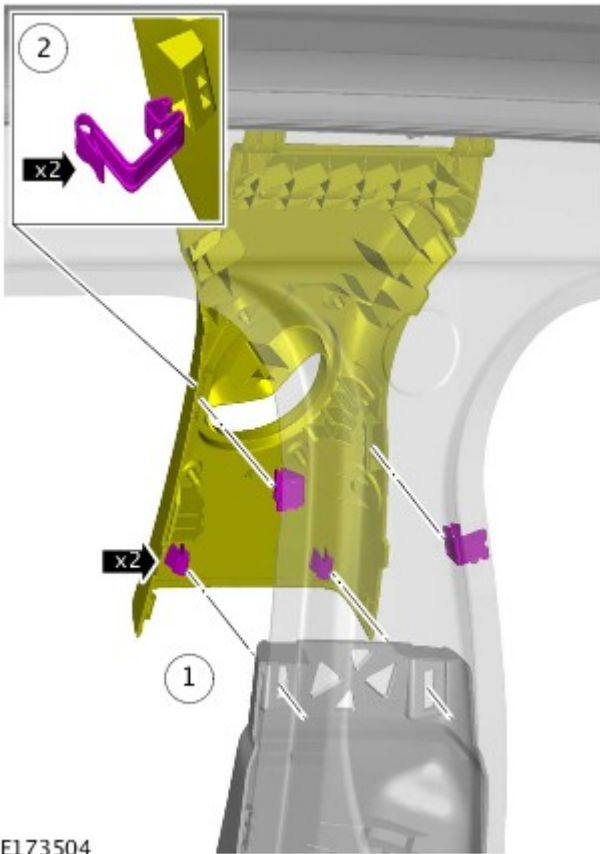

E173504

4. Remove the b-pillar upper trim panel.

1. Release the b-pillar upper trim panel from the b-pillar.

2. Release the 2 upper locating arms.

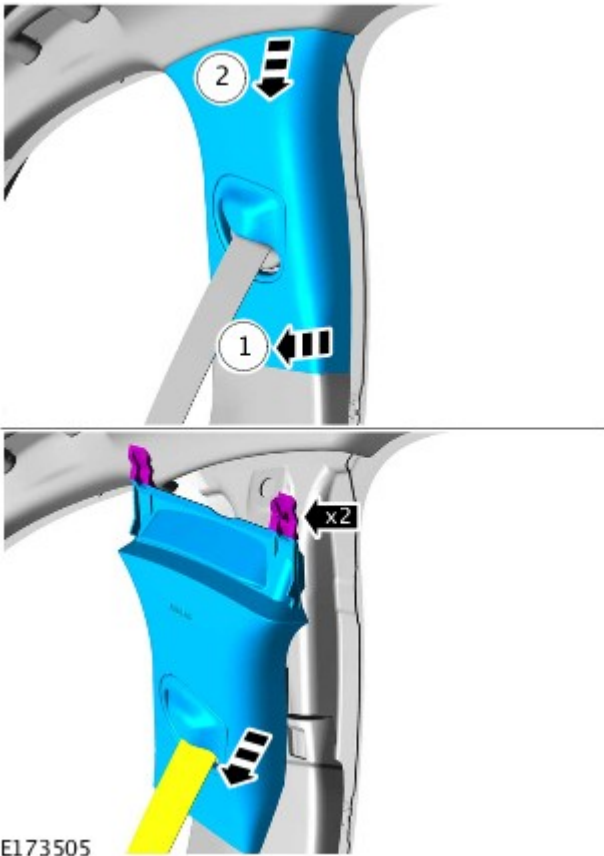

5. Remove the front treadplate.

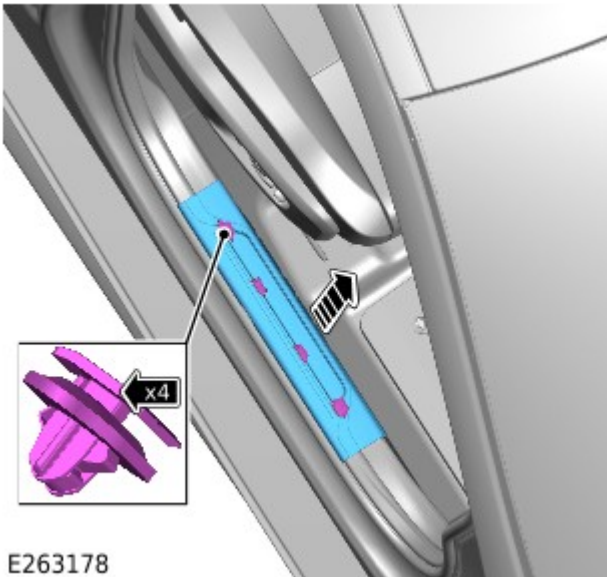

6. Remove the rear treadplate.

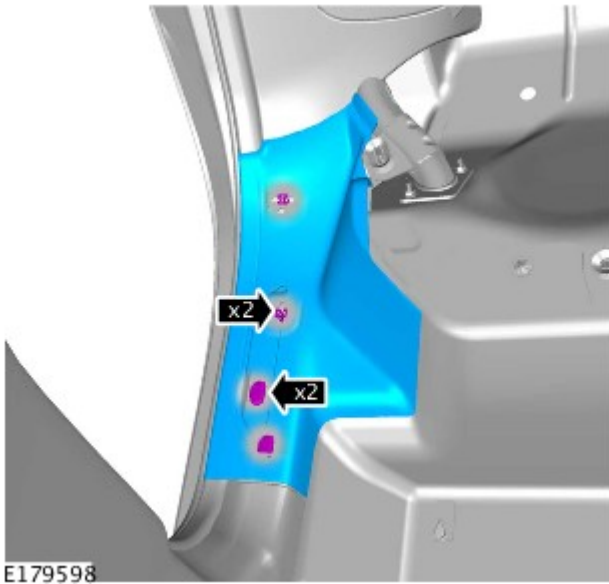

7. Remove the b-pillar lower trim panel.

- Release the 4 trim clips.

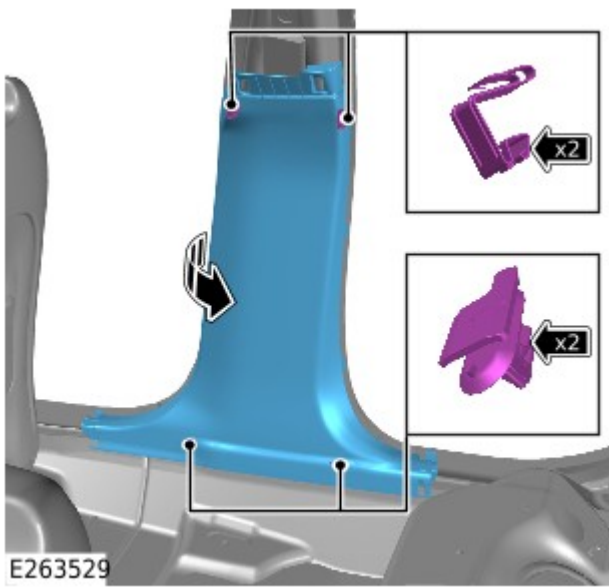

8. Repeat steps 1 to 7 for the opposite side of the vehicle.

9. Inspect both front safety belt retractors for damage shown in the area marked 'A' in the illustrations.

- Any front safety belt retractors which **are** damaged, as shown in the illustration marked with a RED 'X', must be renewed. Continue to step 10 to renew any damaged front safety belt retractors.
- If both front safety belt retractors **are not** damaged, as shown in the illustration marked with a GREEN '✓', reverse steps 1 to 8 above.

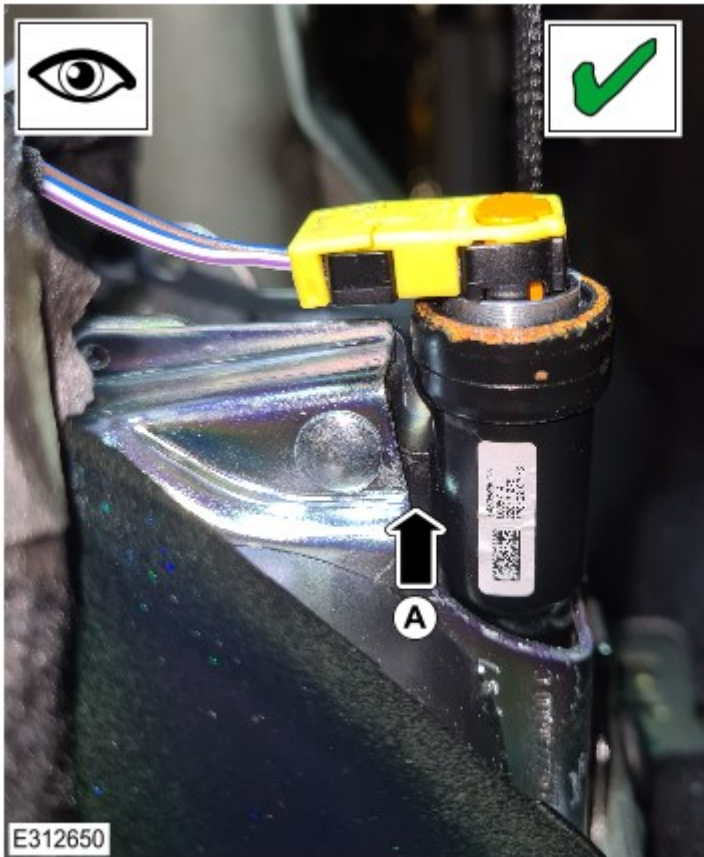

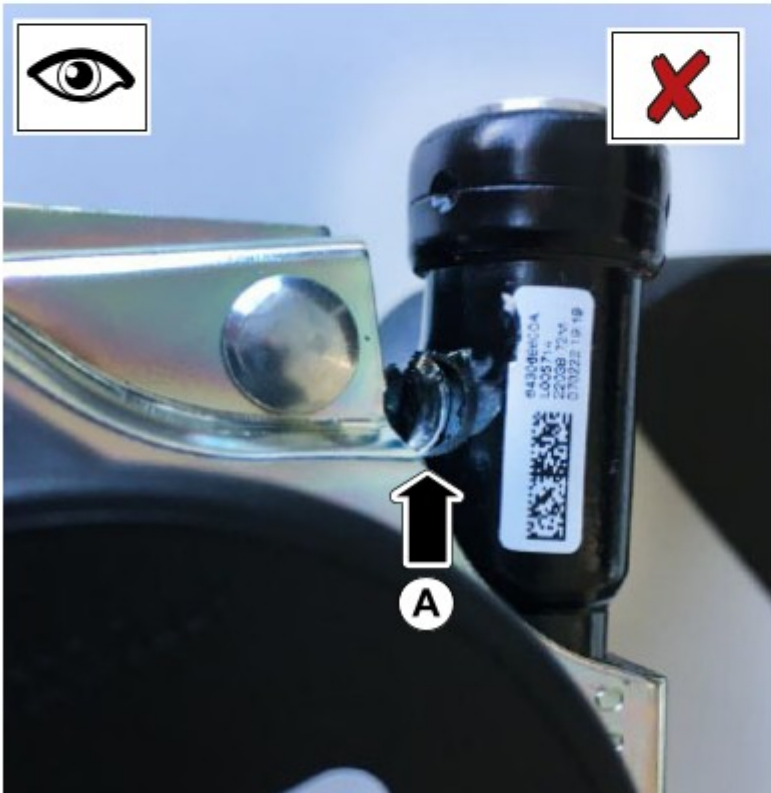

E312651

10. Renew the damaged front safety belt retractor(s), (see TOPIx Workshop Manual section 501-20: Seatbelt System - Removal and Installation - Front Safety Belt Retractor).

SERVICE INSTRUCTION 2 - XE VEHICLES

NOTES:



Some illustrations may vary depending on the vehicle specification but the essential information is always correct.



Some components are shown removed from the vehicle to provide extra clarity.



Front safety belt retractor is also known as front row seatbelt retractor in the TOPlx Workshop Manual.

1. Position the front row seat to the most forward position.

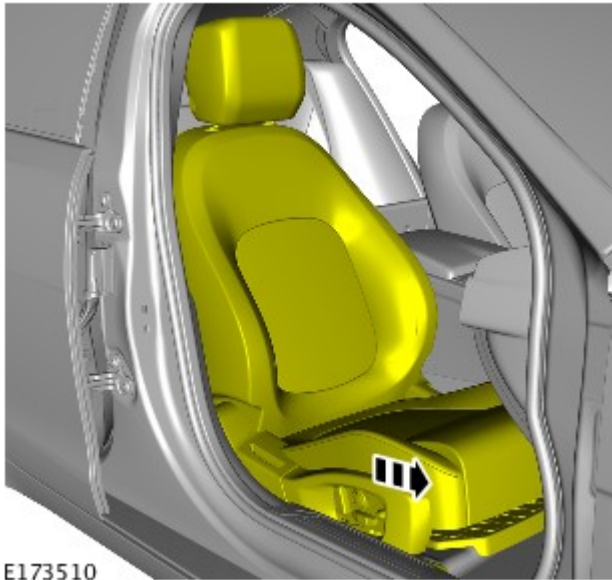

E173510

2. Release the 2 door aperture seals.



E173508

3. Release, but do not fully remove the b-pillar upper trim panel.

1. Release the 2 lower trim clips.

2. Release the 2 center clips.

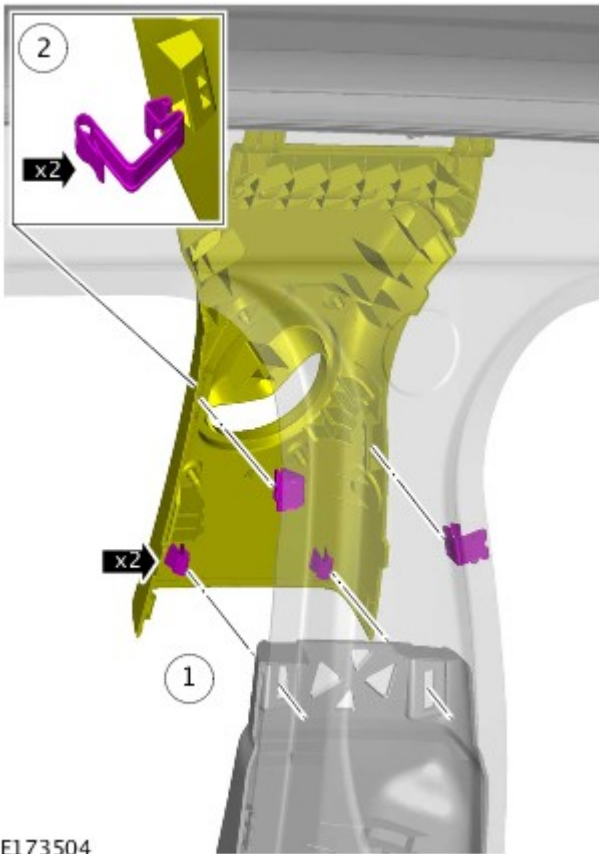

E173504

4. Remove the b-pillar upper trim panel.

1. Release the b-pillar upper trim panel from the b-pillar.

2. Release the 2 upper locating arms.

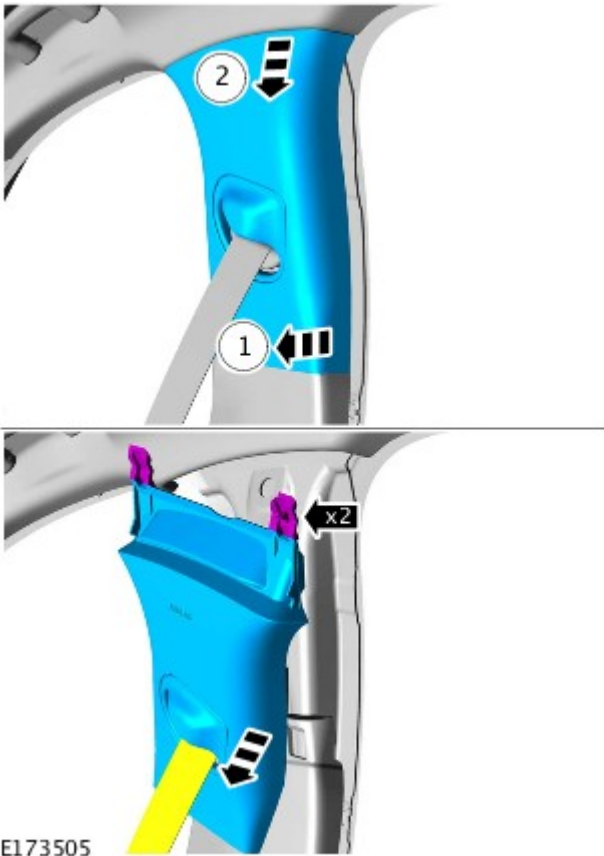

5. Remove the front treadplate.

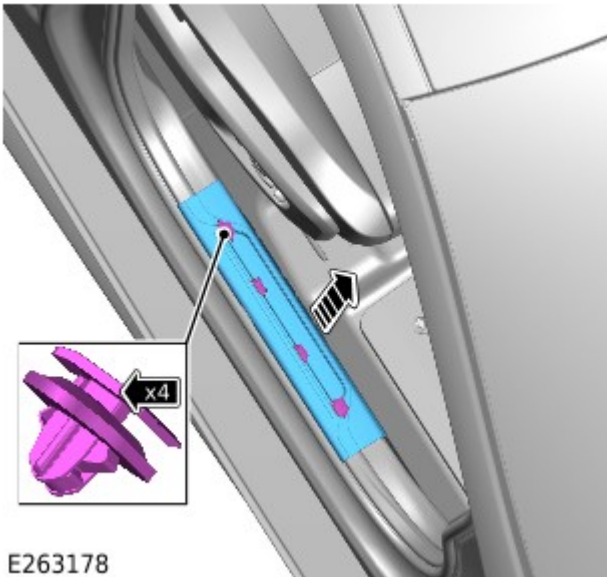

6. Release the second row seat cushion.

- Release the 2 second row center seatbelt buckles.
- Release the 4 clips.

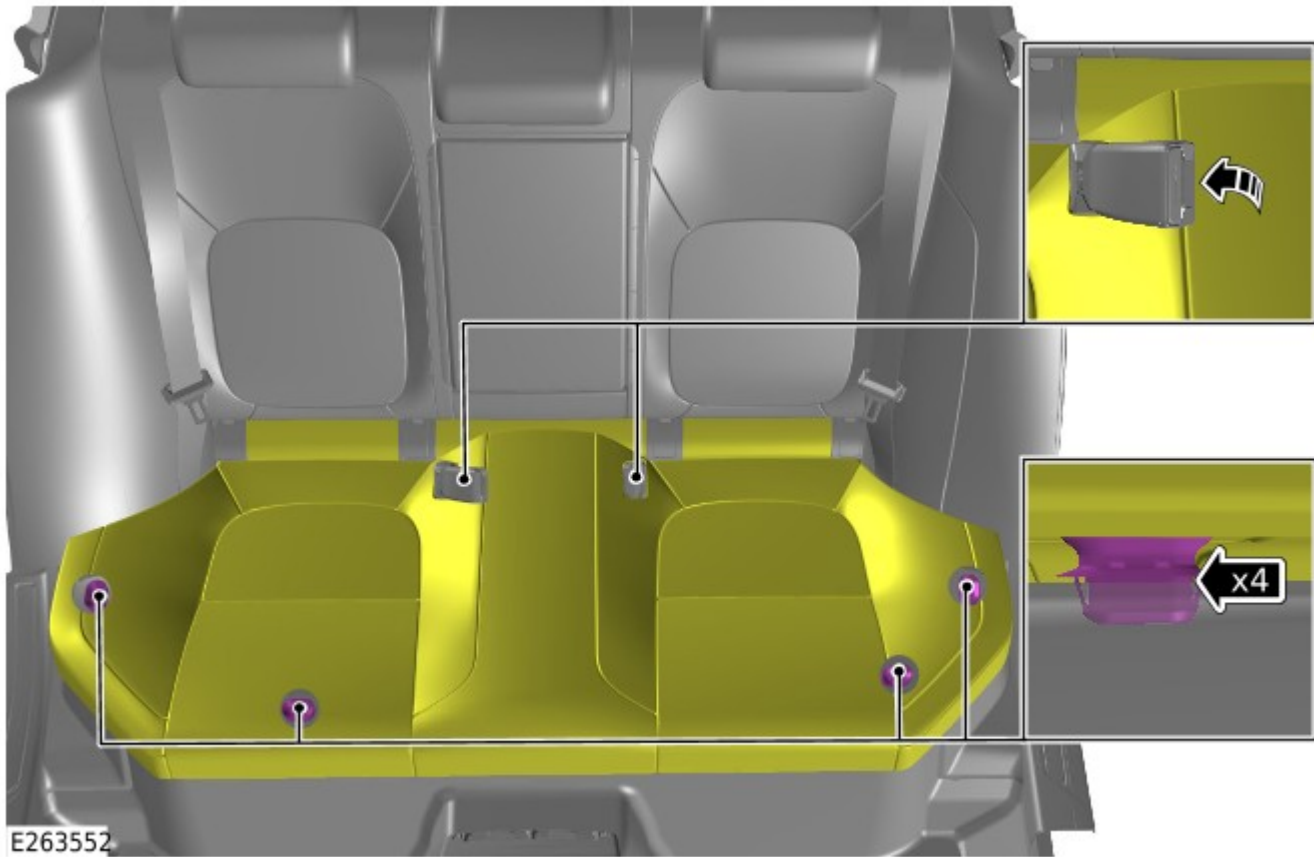

7. Remove the rear treadplate.

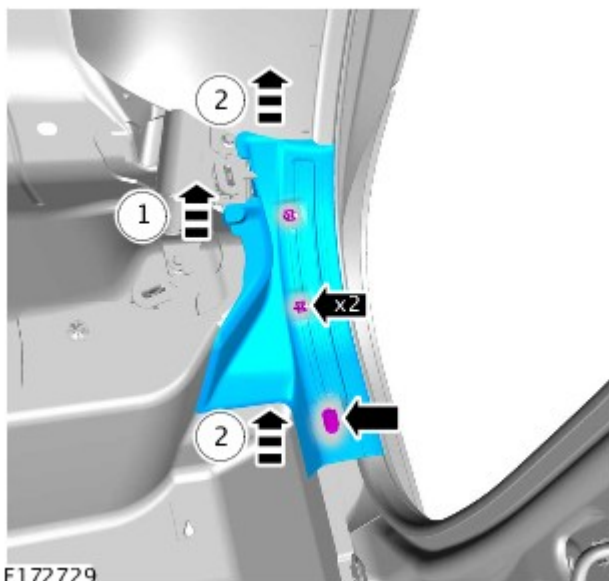

8. Remove the b-pillar lower trim panel.

- Release the 4 trim clips.

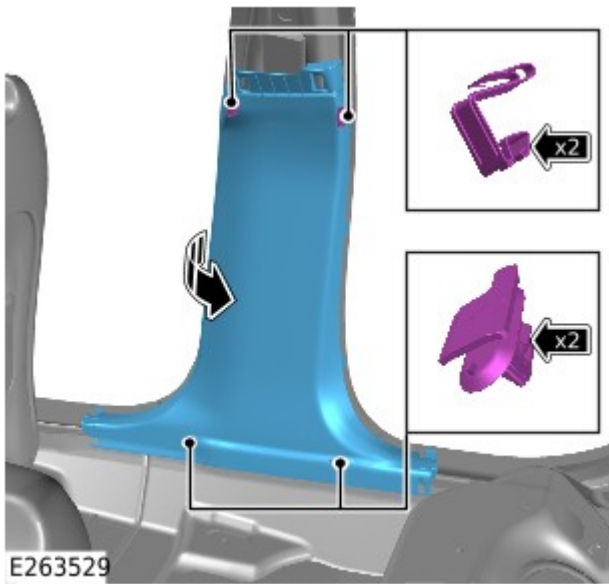

9. Repeat steps 1 to 8 for the opposite side of the vehicle.

10. Inspect both front safety belt retractors for damage shown in the area marked 'A' in the illustrations.

- Any front safety belt retractors which **are** damaged, as shown in the illustration marked with a RED 'X', must be renewed. Continue to step 11 to renew any damaged front safety belt retractors.
- If both front safety belt retractors **are not** damaged, as shown in the illustration marked with a GREEN '✓', reverse steps 1 to 9 above.

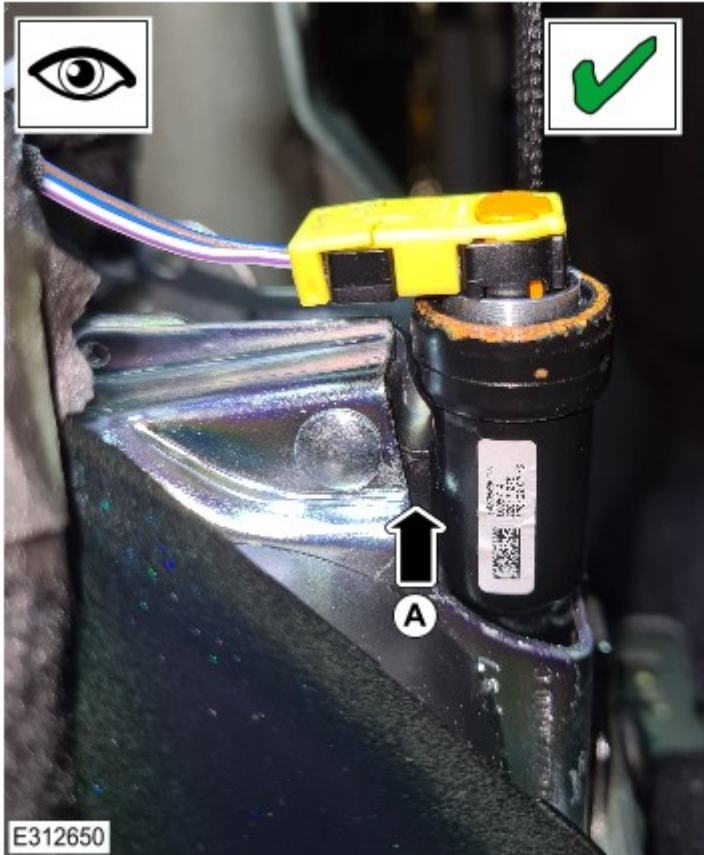

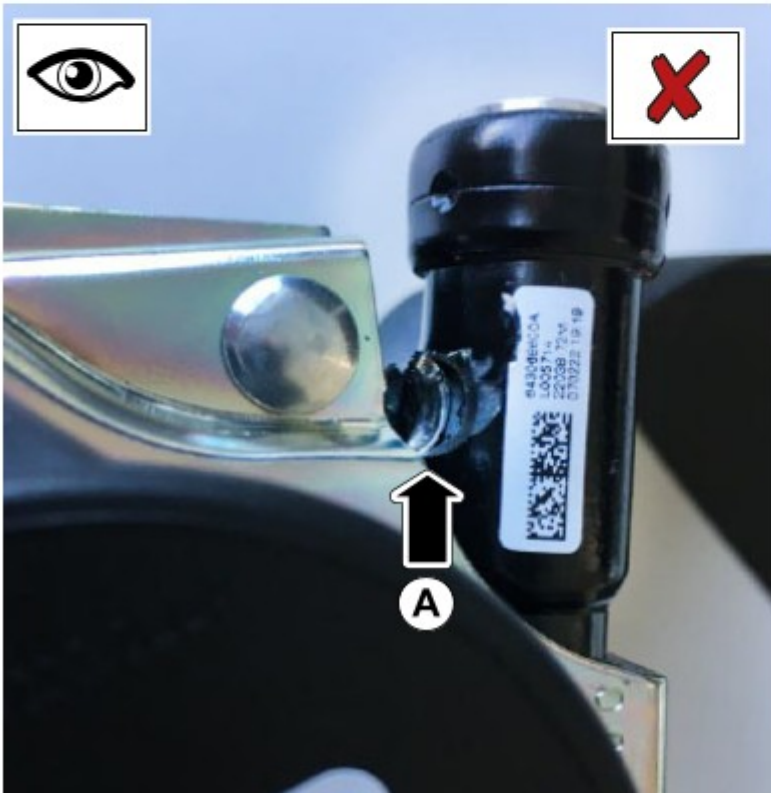

E312651

11. Renew the damaged front safety belt retractor(s), (see TOPIx Workshop Manual section 501-20: Seatbelt System - Removal and Installation - Front Safety Belt Retractor).

SERVICE INSTRUCTION 3 - F-PACE VEHICLES

NOTES:



Some illustrations may vary depending on the vehicle specification but the essential information is always correct.



Some components are shown removed from the vehicle to provide extra clarity.



Front safety belt retractor is also known as front row seatbelt retractor in the TOPlx Workshop Manual.

1. Position the front row seat to the most forward position.

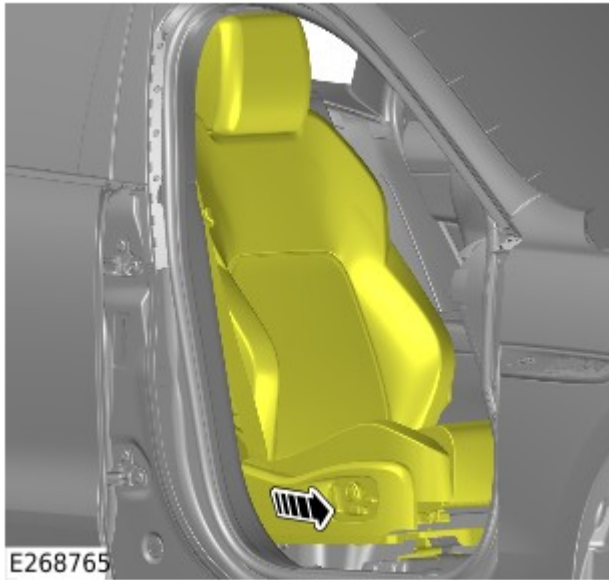

2. Release the 2 door aperture seals.



3. Release, but do not fully remove the b-pillar upper trim panel.

1. Release the 2 lower trim clips.

2. Release the 2 center clips.

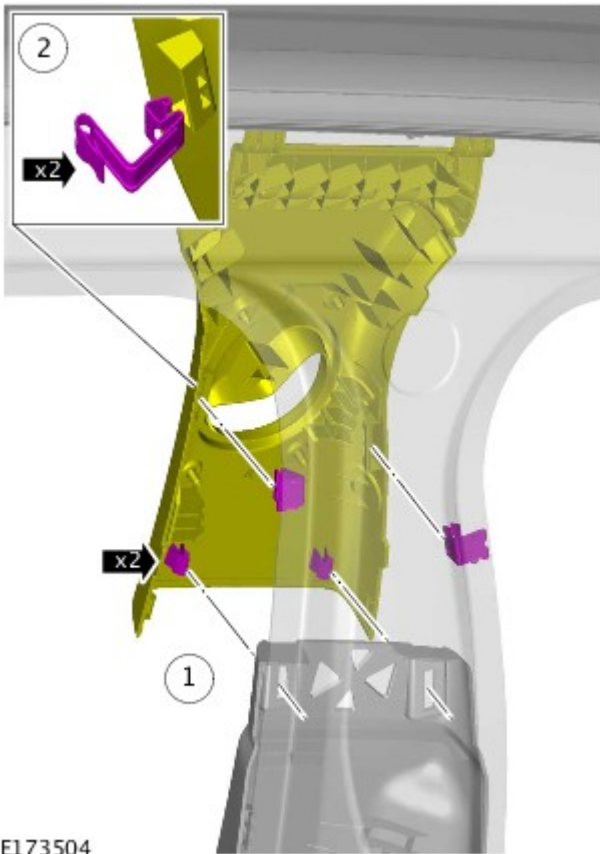

E173504

4. Remove the b-pillar upper trim panel.

1. Release the b-pillar upper trim panel from the b-pillar.

2. Release the 2 upper locating arms.

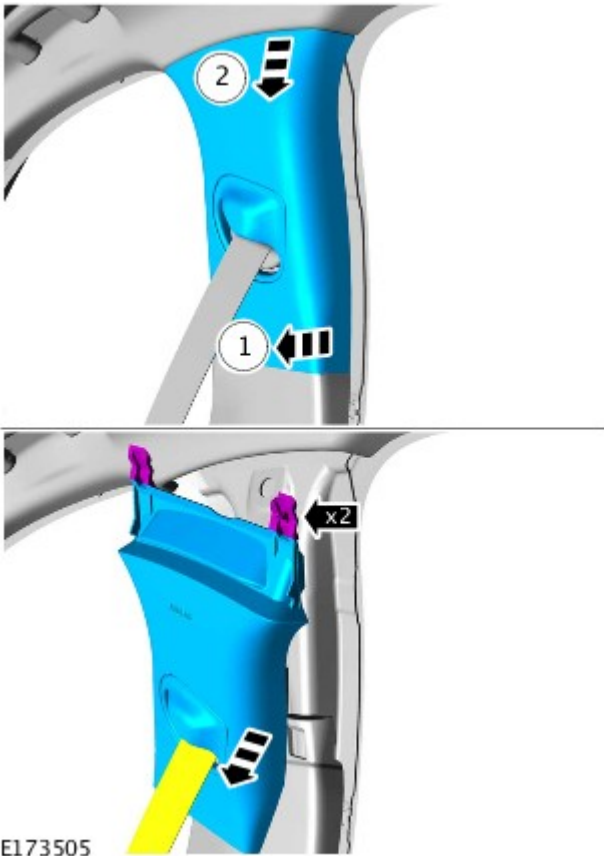

E173505

5.



NOTE: Do not disconnect the electrical connector.

Release the front treadplate.

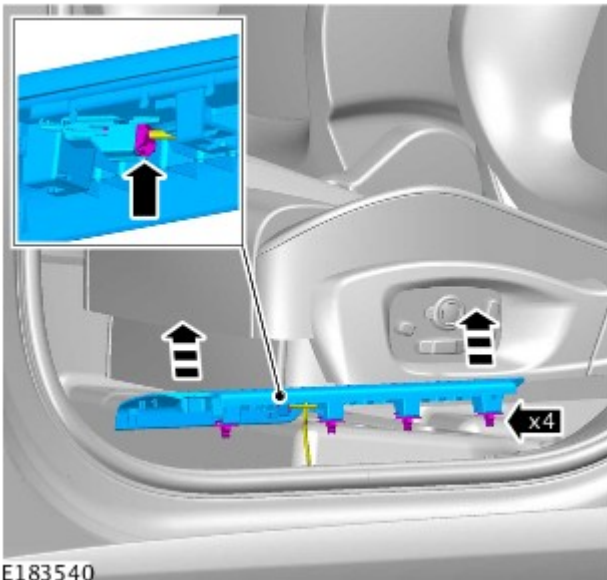

E183540

6. Release the second row seat cushion.

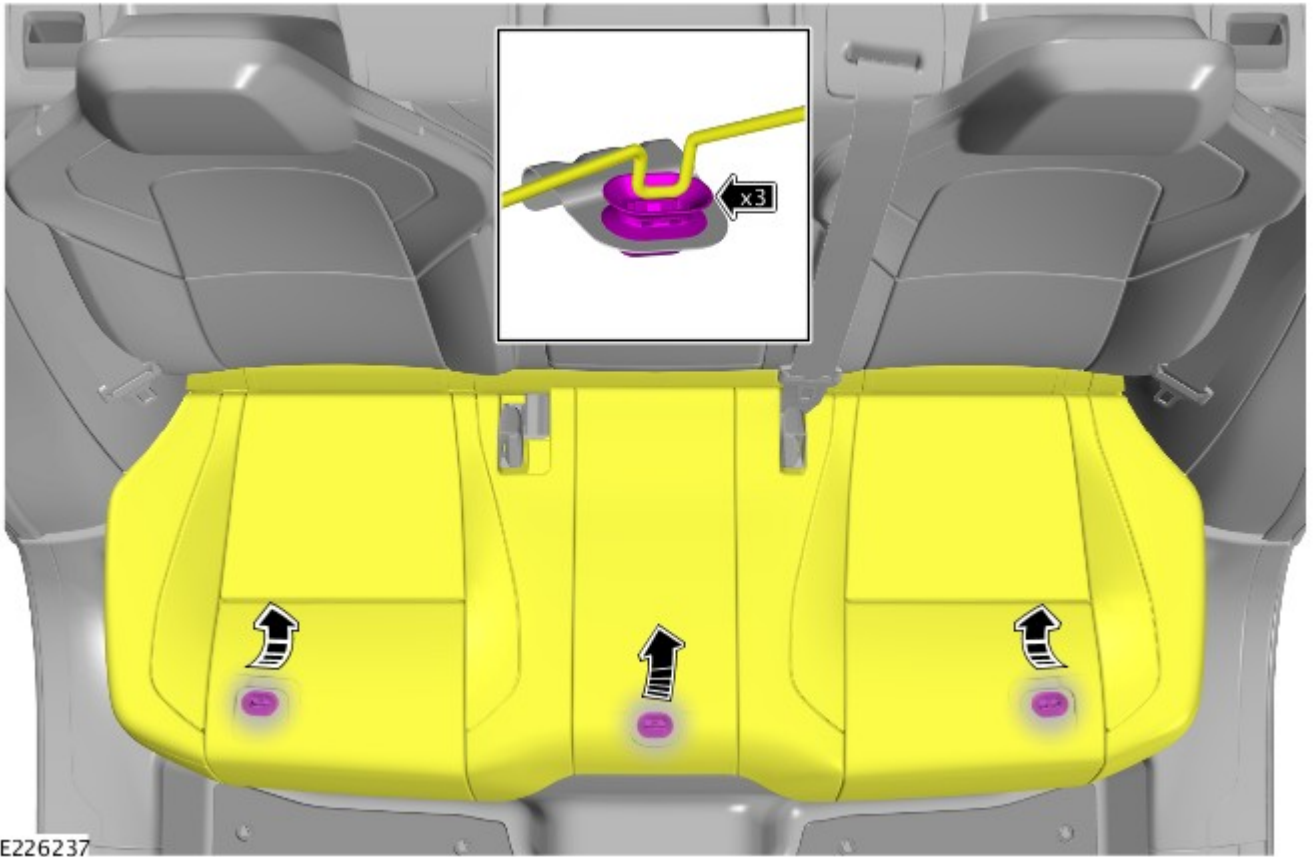

E226237

7.



NOTE: Do not disconnect the electrical connector.

Release the rear treadplate.

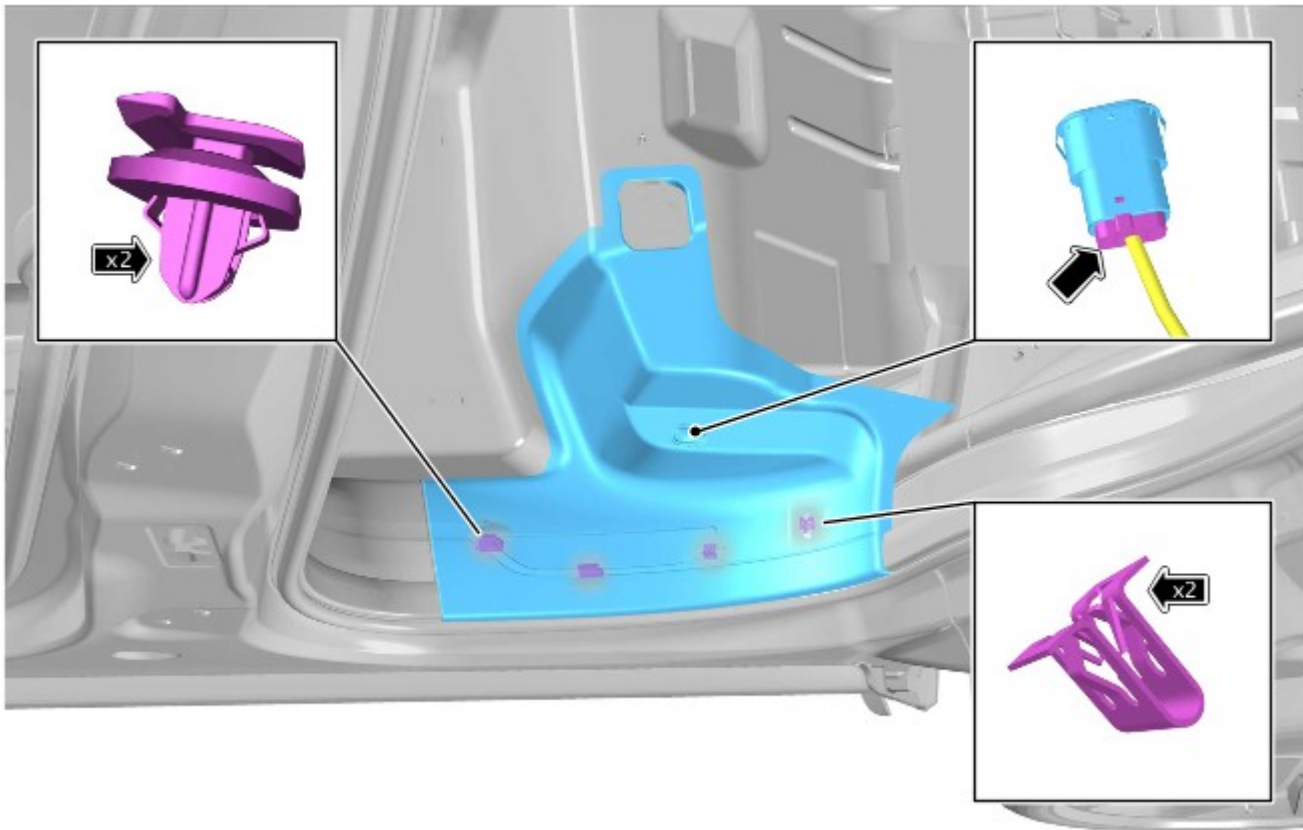

E227561

8. Remove the b-pillar lower trim panel.

- Release the 4 trim clips.

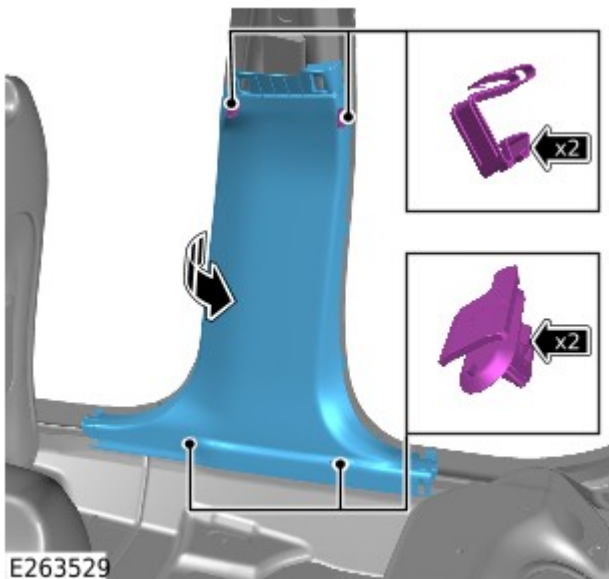

E263529

9. Repeat steps 1 to 8 for the opposite side of the vehicle.

10.



NOTE: Use a suitable telescopic/flexible mirror to assist with this step.

Inspect both front safety belt retractors for damage shown in the area marked 'A' in the illustrations.

- Any front safety belt retractors which **are** damaged, as shown in the illustration marked with a RED 'X', must be renewed. Continue to step 11 to renew any damaged front safety belt retractors.
- If both front safety belt retractors **are not** damaged, as shown in the illustration marked with a GREEN '✓', reverse steps 1 to 9 above.

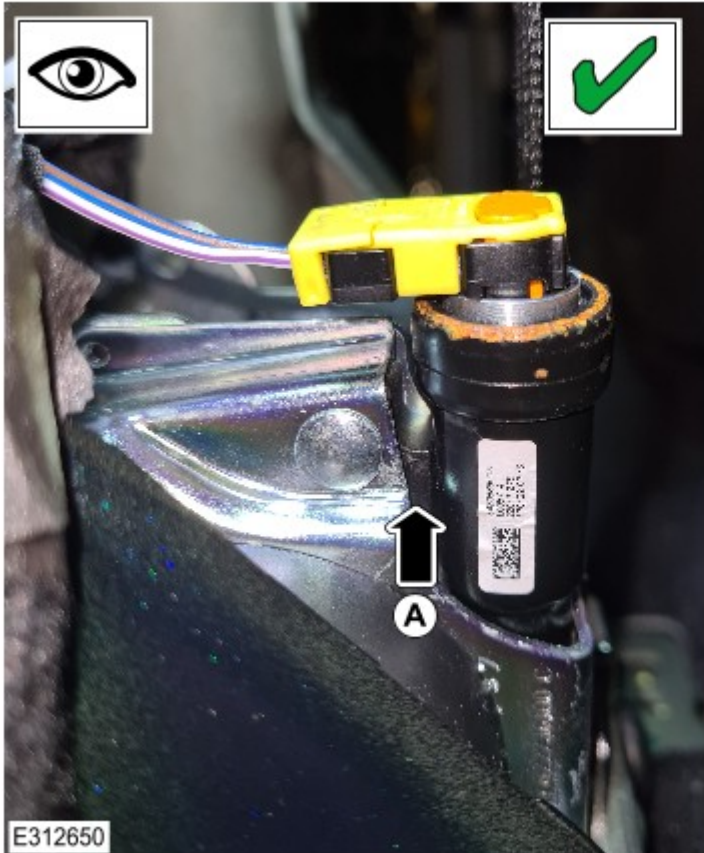

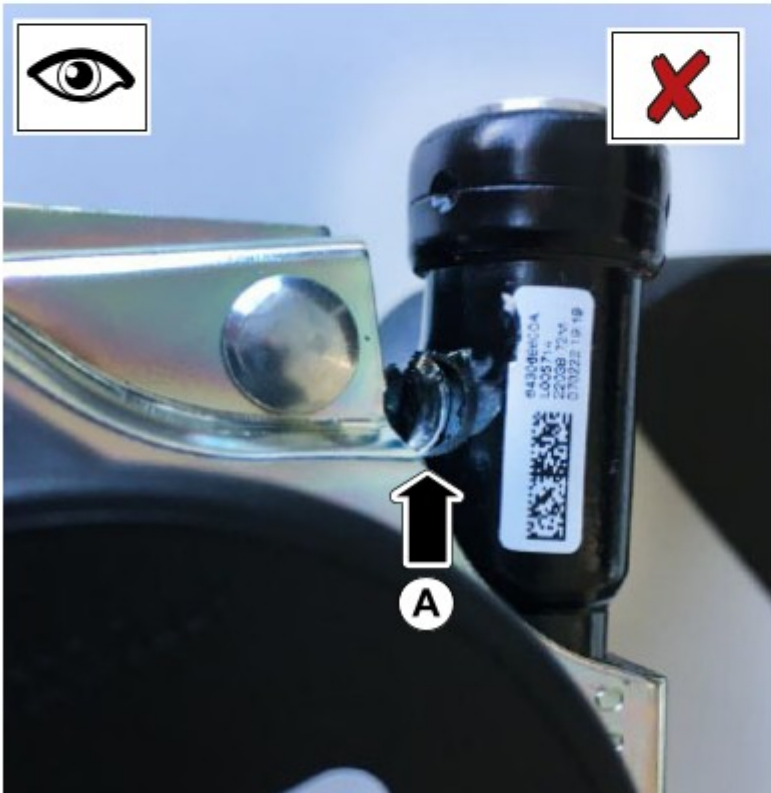

E312651

11. Renew the damaged front safety belt retractor(s), (see TOPIx Workshop Manual section 501-20: Seatbelt System - Removal and Installation - Front Safety Belt Retractor).

SERVICE INSTRUCTION 4 - F-TYPE VEHICLES

NOTES:



Some illustrations may vary depending on the vehicle specification but the essential information is always correct.



Some components are shown removed from the vehicle to provide extra clarity.



Front safety belt retractor is also known as front row seatbelt retractor in the TOPlx Workshop Manual.

FIXED ROOF VEHICLES ONLY



1.



NOTE: Repeat this step for the opposite side of the vehicle.

Position the front row seat to the most forward position.

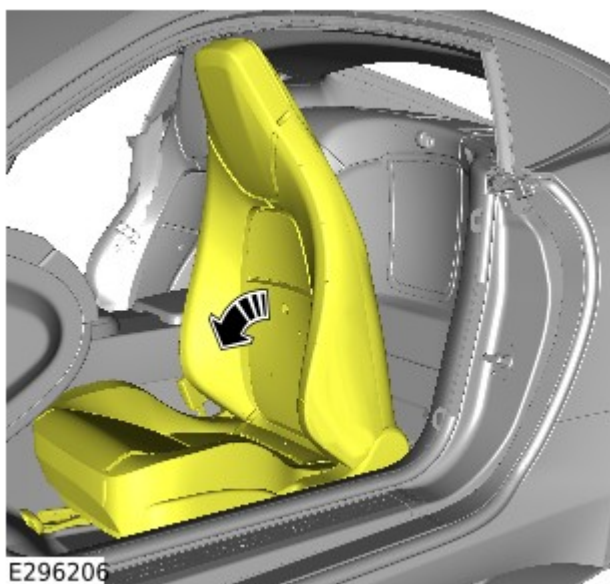

2.



NOTE: Repeat this step for the opposite side of the vehicle.

Reposition the front seat backrest for access.

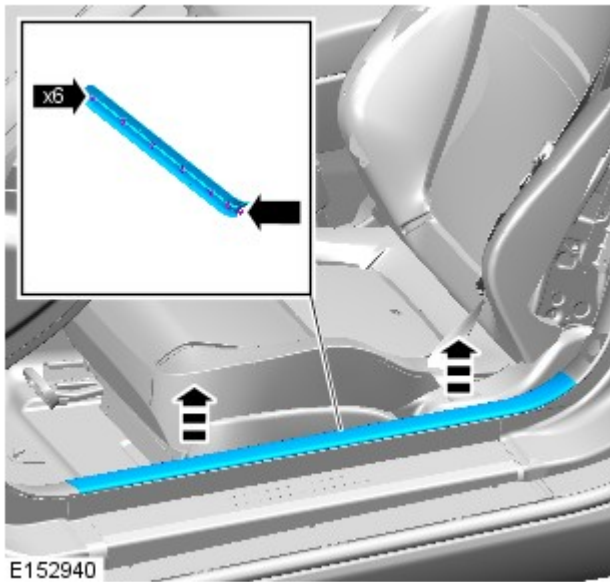

3.



NOTE: Repeat this step for the opposite side of the vehicle.

Remove the front treadplate.

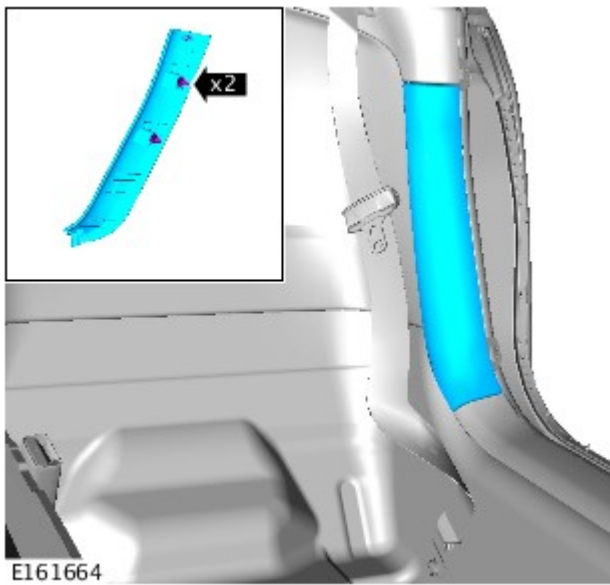

4.



NOTE: Repeat this step for the opposite side of the vehicle.

Remove the trim panel.

5. Remove the trim panel.

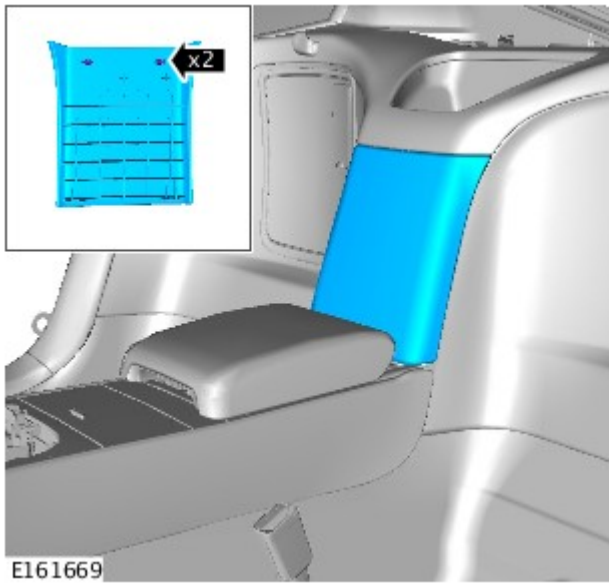

6. Remove the parcel shelf.

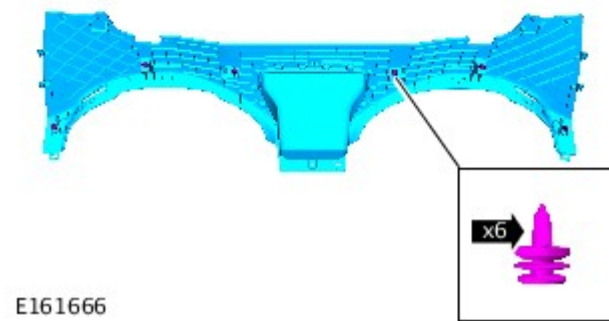
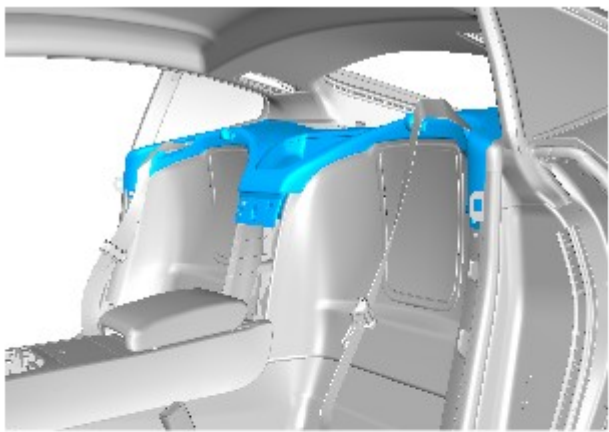

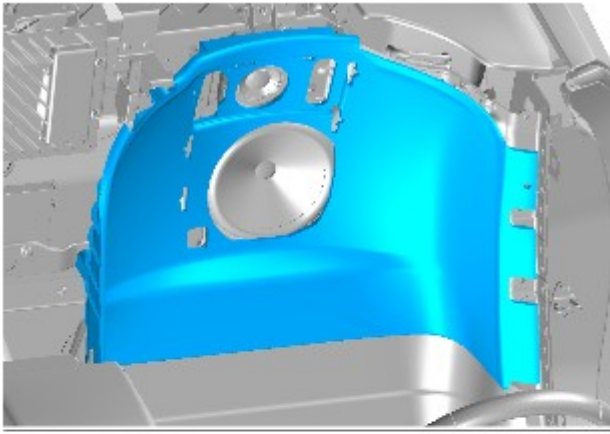

7.



NOTE: Repeat this step for the opposite side of the vehicle.

Remove the trim panel.

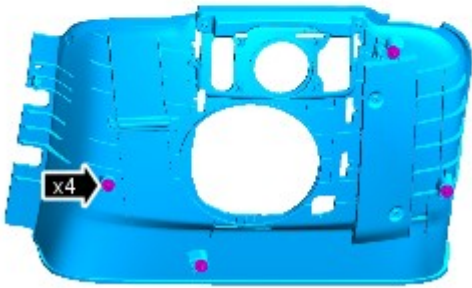

E152941

8. Inspect both front safety belt retractors for damage shown in the area marked 'A' in the illustrations.

- Any front safety belt retractors which **are** damaged, as shown in the illustration marked with a RED 'X', must be renewed. Continue to step 9 to renew any damaged front safety belt retractors.
- If both front safety belt retractors **are not** damaged, as shown in the illustration marked with a GREEN '✓', reverse steps 1 to 7 above.

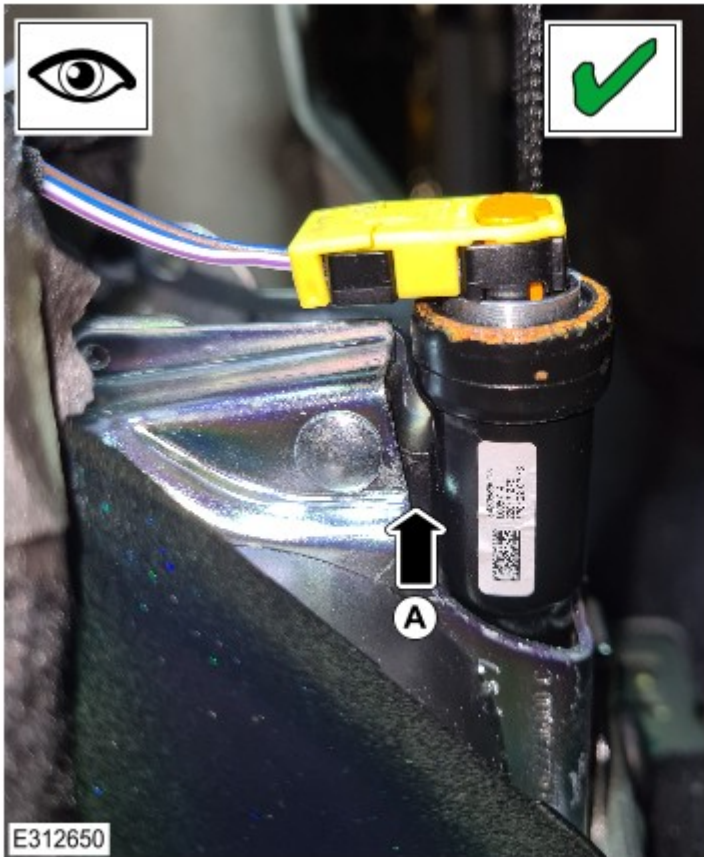



E312651

9. Renew the damaged front safety belt retractor(s), (see TOPIx Workshop Manual section 501-20: Seatbelt System - Removal and Installation - Front Safety Belt Retractor).

FOLDING TOP VEHICLES ONLY

10. Disconnect the startup battery, (see TOPIx Workshop Manual section 414-01: Battery, Mounting And Cables - General Procedures - Startup Battery Disconnect And Connect)

11.



NOTE: Repeat this step for the opposite side of the vehicle.

Position the front row seat to the most forward position.

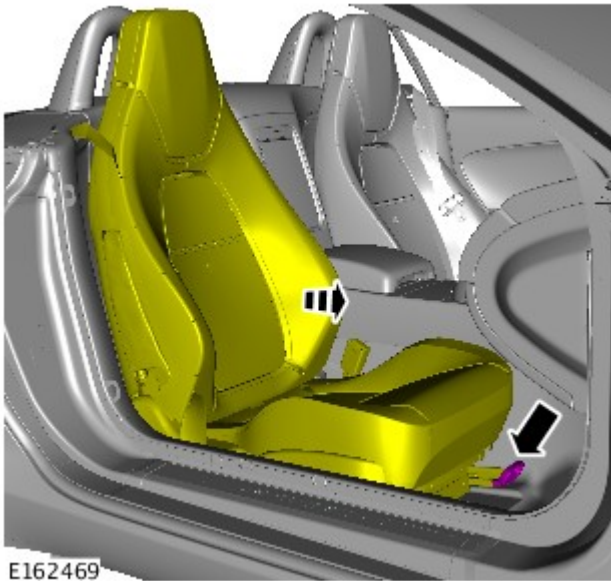

E162469

12.



NOTE: Repeat this step for the opposite side of the vehicle.

Reposition the front seat backrest for access.

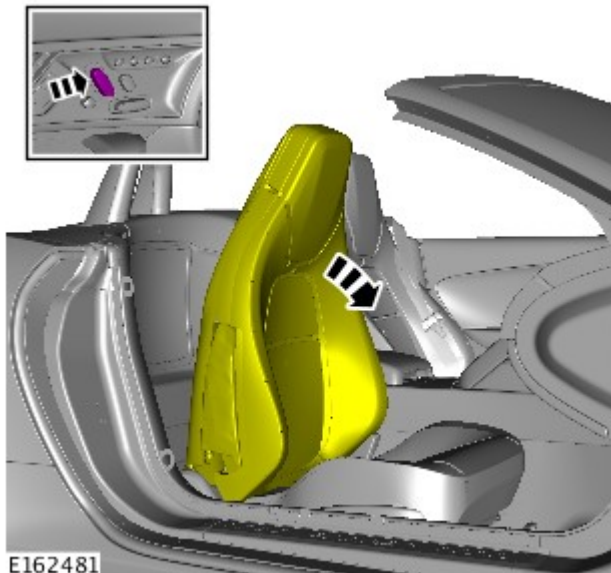

E162481

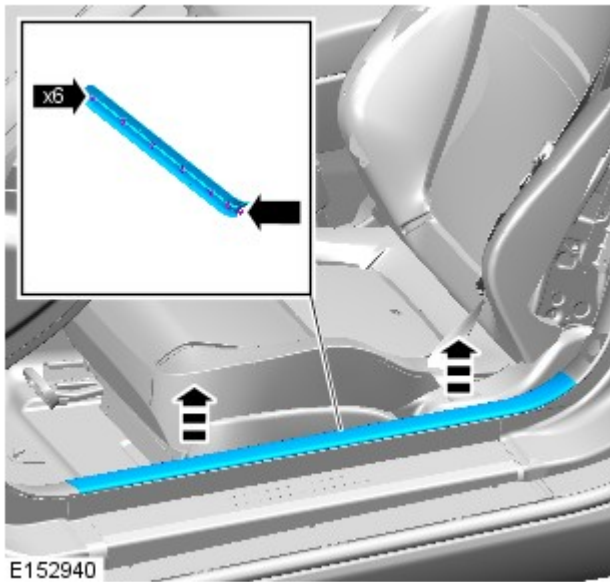

13.



NOTE: Repeat this step for the opposite side of the vehicle.

Remove the front treadplate.

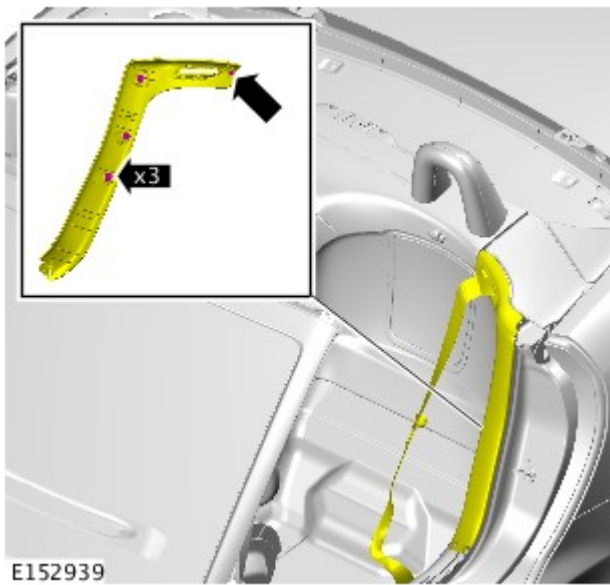

14.



NOTE: Repeat this step for the opposite side of the vehicle.

Release the trim.

15. Remove the trim panels.

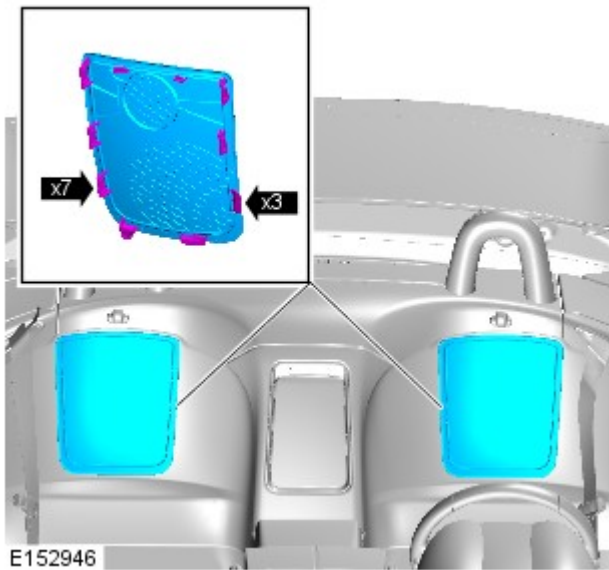

16.



NOTE: Repeat this step for the opposite side of the vehicle.

Remove the roll-over protection bar.

- **Torque:** 45 Nm

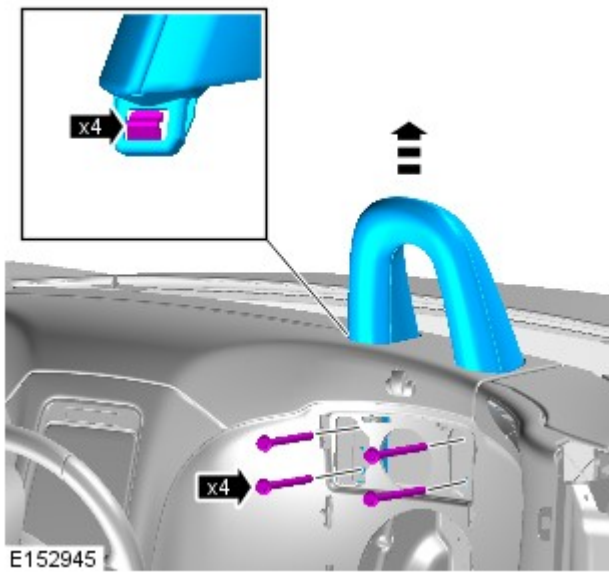

17. Remove the trim clips.

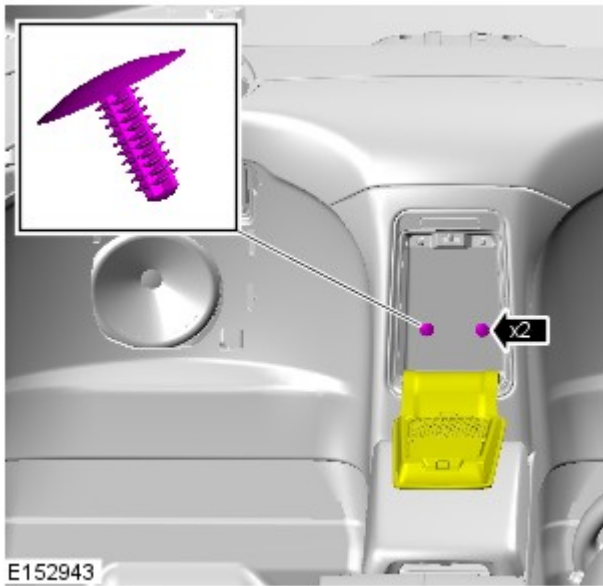

18. Remove the parcel shelf.

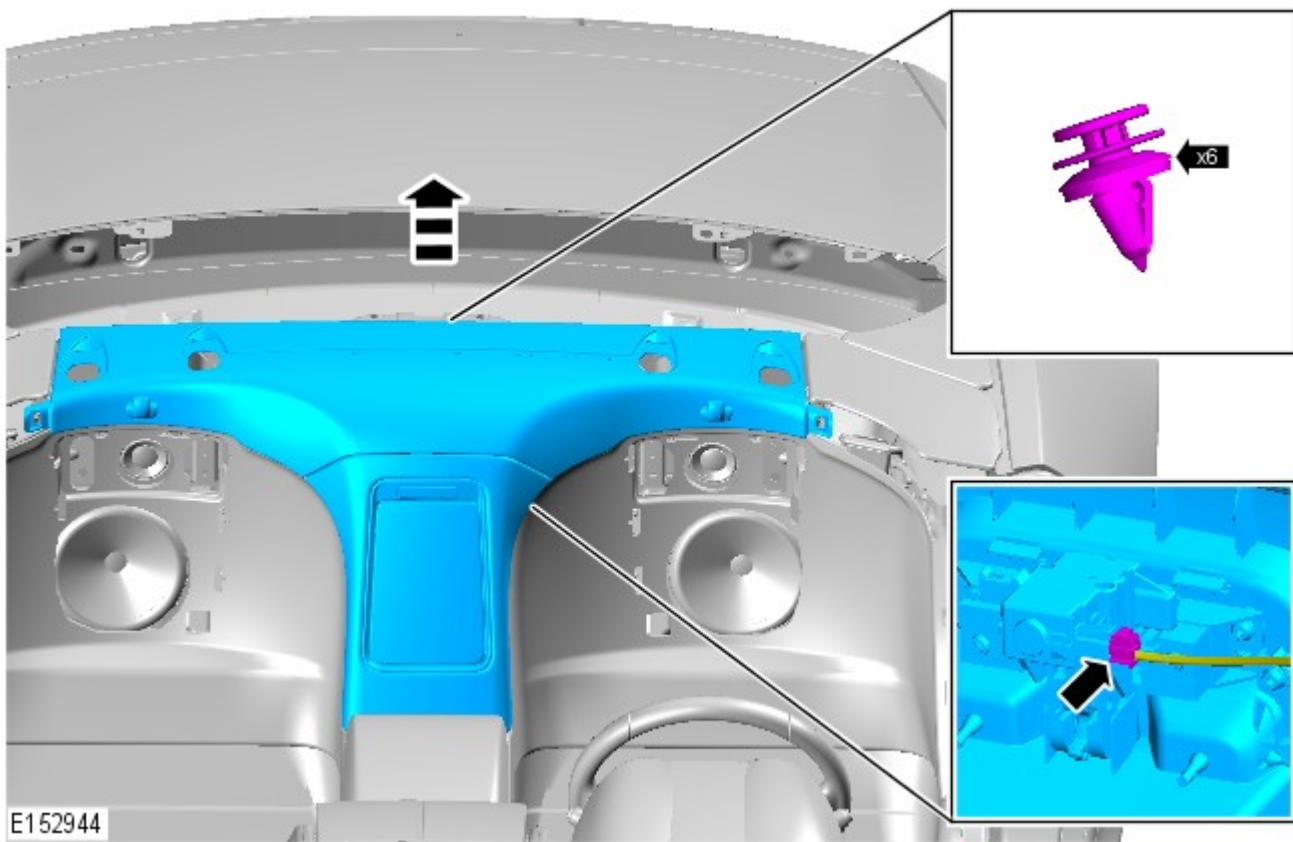

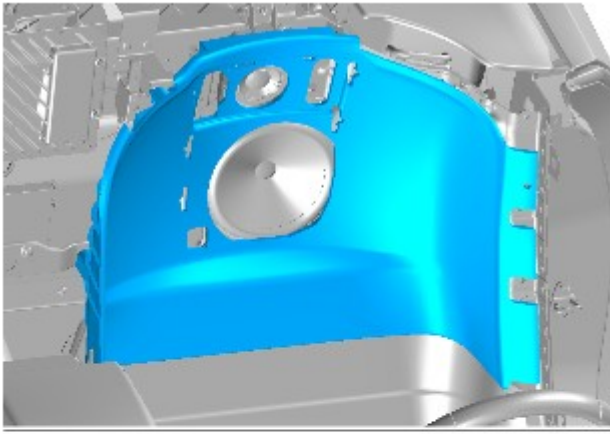

19.



NOTE: Repeat this step for the opposite side of the vehicle.

Remove the trim panel.

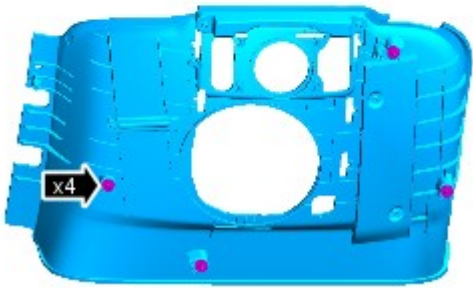

E152941

20. Inspect both front safety belt retractors for damage shown in the area marked 'A' in the illustrations.

- Any front safety belt retractors which **are** damaged, as shown in the illustration marked with a RED 'X', must be renewed. Continue to step 21 to renew any damaged front safety belt retractors.
- If both front safety belt retractors **are not** damaged, as shown in the illustration marked with a GREEN '✓', reverse steps 10 to 19 above.

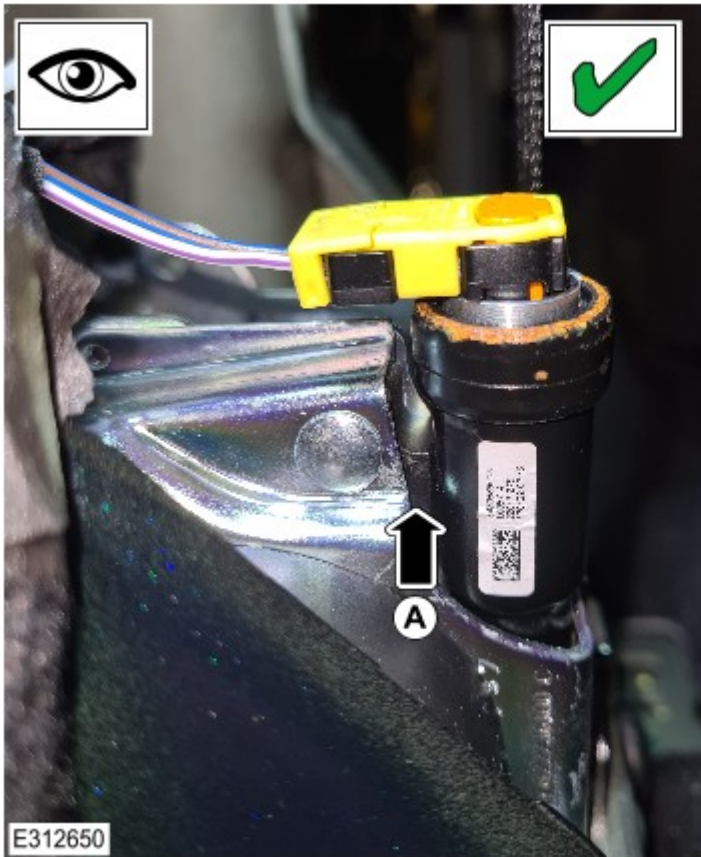



E312651

21. Renew the damaged front safety belt retractor(s), (see TOPIx Workshop Manual section 501-20: Seatbelt System - Removal and Installation - Front Safety Belt Retractor).

SAMPLE CUSTOMER LETTER - FOR INFORMATION ONLY

Name
Address line 1
Address line 2
Address line 3
Post Code

Vehicle Identification Number (VIN):
Registration Number:
Program Number: H412

Date: month/year

**SAFETY RELATED RECALL - F-PACE, F-TYPE, XE and XF vehicles - Autoliv Seatbelt Retractor
Functionality**

Dear

Jaguar Land Rover Limited would like to advise you that during ongoing quality assessment of our product it has been identified that a possible safety related problem may occur on certain Jaguar vehicles within a specific production range. Please read the information below, this will explain the actions that we intend to take and what you will need to do.

Why are we contacting you?

We have identified that the seatbelt pretensioner tube installed on the front seatbelt retractor may have been damaged during the manufacturing process. The damaged tube could prevent the pretensioner from correctly operating by not pre-tensioning the seatbelt in the event of an accident, where it would normally operate. This may result in a reduction or complete loss of pre-tensioning in the event of a crash and increased occupant injury.

What will your Jaguar retailer/authorized repairer do?

We will inspect the seatbelt pretensioner tube for damage and renew the seatbelt retractor if required.

How long will it take?

The work on your vehicle will be completed as quickly and efficiently as possible in order to minimize inconvenience to you. Your retailer/authorized repairer will be able to advise how long your vehicle will be required for when a booking is made.

What we are asking you to do

Please contact your preferred Jaguar retailer/authorized repairer without delay. To book your vehicle in for this action you will need to provide the retailer/authorized repairer with the following which are detailed at the beginning of this letter:

- The VIN for your vehicle
- Vehicle registration number of your vehicle.
- The program code for the action.

If you do not have a retailer/authorized repairer, please access or www.jaguar.com for contact details.

If you no longer own the vehicle could you please complete the 'Change of Ownership' slip attached to this letter, returning the slip to Jaguar Land Rover Limited immediately in the enclosed 'Freepost' envelope. This will enable us to make contact with the new owner.

If you have concerns

If you experience any concerns relating to this Recall, contact the Service Manager at the retailer/authorized repairer for assistance or contact the JLR Limited Customer Experience Centre on 0345 303 2303 or (enter phone number).

This bulletin is being issued in accordance with the legislative or industry requirements concerning vehicle defects. The authorities will closely monitor the response rate of this bulletin.

Please treat this matter with the urgency it requires, JLR Limited apologize for any inconvenience this bulletin may cause and thank you, in advance, for your co-operation.

Yours sincerely

Head of Business

Technical Questions And Answers



FOR USE ON ENQUIRY

Jaguar Land Rover H412

2022 model year F-TYPE, XE and XF vehicles and 2022 and 2023 model year F-PACE vehicles Seatbelt Pretensioner Functionality

A concern has been identified on certain 2022 model year F-TYPE, XE and XF vehicles and certain 2022 and 2023 model year F-PACE vehicles where, due to a retailer production issue, a damaged front seatbelt pretensioner tube may have been installed on the seatbelt retractor. The damaged tube could prevent the pretensioner from operating correctly in the event of an accident.

Question 1

Why is Jaguar Land Rover (JLR) Limited recalling these vehicles?

Answer

JLR is conducting a voluntary safety recall involving certain 2022 model year F-TYPE, XE and XF vehicles and certain 2022 and 2023 model year F-PACE vehicles. Customers will be asked to take their vehicles to an approved retailer/authorized repairer to have the seatbelt pretensioner tube inspected for damage and if damage is identified, the seatbelt retractor will be renewed.

Question 2

Can you tell me more about what is wrong with the vehicles?

Answer

Autoliv (seatbelt retailer) made JLR aware of a manufacturing concern detected on some front seatbelt retractors that results in damage to the pretensioner tube caused during seatbelt retractor assembly. This may result in a reduced level or complete loss of pre-tensioning in the event of a crash and increased occupant injury.

Question 3

How would the customer become aware of their vehicle potentially having this concern?

Answer

This concern may manifest itself only in the event of a crash where a seatbelt pretensioner would normally operate.

Question 4

Does this concern affect vehicle safety?

Answer

JLR has determined that the seatbelt pretensioner not operating correctly could pose a risk to vehicle safety in the event of an accident.

Question 5

Has JLR received many complaints?

Answer

JLR has received no field reports of vehicles that could be attributed to this issue.

Question 6

Have there been any accidents or injuries or fires?

Answer

There have been no reports of accidents or injuries or fires relating to this concern of which JLR is aware.

Question 7

How was the concern discovered?

Answer

JLR were notified of this concern by the seatbelt manufacturer, Autoliv.

Question 8

How long has JLR known about this concern?

Answer

JLR were notified of this concern on April 8, 2022.

Question 9

Is the defect leading you to any concerns regarding the reliability of a system, which is supposed to be designed and engineered for the passengers' safety? What type of measures are you planning to take?

Answer

JLR has no concerns with the overall reliability of the vehicle. JLR carefully monitors field data to make sure that any matters relating to safety and compliance are rigorously investigated.

Question 10

What has JLR done in production?

Answer

This is a JLR retailer issue which has been addressed in the retailer manufacturing process by introducing sensors to detect mis-positioning of the retractor and stop the manufacturing process where mis-positioning is detected.

Question 11

What will retailers/authorized repairers do to the vehicles?

Answer

Retailers/authorized repairers will inspect the front seatbelt pretensioner tubes for damage and if damage is identified, the seatbelt retractor will be replaced.

Question 12

Which vehicles are affected by this recall?

.

Answer

Certain 2022 and 2023 model year Jaguar vehicles within the Vehicle Identification Number (VIN) ranges are potentially affected:

- F-PACE from SADCJ2EX2NA693574 to SADCA2BW5NA695394 (Solihull Manufacturing Plant)
- F-TYPE from SAJDB1BX5NCK78735 to SAJDA1AE4NCK79393 (Castle Bromwich Manufacturing Plant)
- XE from SAJAA4BN1NCP69339 to SAJAB4BNXNCP69420 (Castle Bromwich Manufacturing Plant)
- XF from SAJBL4GX1NCY91515 to SAJBL4GX5NCY91713 (Castle Bromwich Manufacturing Plant)

Question 13

Are other JLR models affected by this concern?

Answer

Yes, certain 2022 and 2023 Model Year Land Rover Defender, Discovery, Discovery Sport, Range Rover Sport and Range Rover Velar vehicles have also been affected.

Question 14

Is the repair available to rework vehicles?

Answer

Parts are available for JLR retailers/authorized repairers to conduct this repair.

Question 15

How much will the recall cost JLR?

Answer

Cost was not a factor in deciding to recall these vehicles.

Question 16

How do I know if my vehicle is affected?

Answer

All owners of potentially affected vehicles will shortly receive a letter inviting them to contact a JLR retailer/authorized repairer for the work to be completed.

Question 17

How long does it take for the vehicle to be inspected and repaired?

Answer

The work will be completed as quickly and efficiently as possible in order to minimize inconvenience to customers and is expected to take no longer than 1 hour to complete. Naturally, due to retailer/authorized repairer schedules, vehicles may be required for longer.

Question 18

Can I safely continue to drive my vehicle until it has been repaired?

Answer

Customers are advised to contact a JLR retailers/authorized repairers should they have any concerns regarding the seatbelt operation.

Note:

Please make sure that any press enquiries are referred to the JLR Corporate Affairs office.