

TECHNICAL INSTRUCTIONS
FOR
SAFETY RECALL 22TA06
POTENTIAL LOSS OF VEHICLE CONTROL
CERTAIN 2023 MODEL YEAR bZ4X

The repair quality of covered vehicles is extremely important to Toyota. All dealership technicians performing this repair are required to successfully complete the most current version of the E-Learning course “Safety Recall and Service Campaign Essentials”. To ensure that all vehicles have the repair performed correctly; technicians performing this repair are required to currently hold at least one of the following certification levels:

- Expert Technician (Hybrid)

Always check which technicians can perform the repair by logging on to <https://www.uotdealerreports.com>. It is the dealership’s responsibility to select technicians with the above certification level or greater to perform this repair. Carefully review your resources, the technician skill level, and ability before assigning technicians to this repair. It is important to consider technician days off and vacation schedules to ensure there are properly trained technicians available to perform this repair at all times.

I. OPERATION FLOW CHART

The flow chart is for reference only. DO NOT use it in place of the full technical instructions. Follow ALL steps as outlined in the full technical instructions to confirm the campaign is completed correctly.

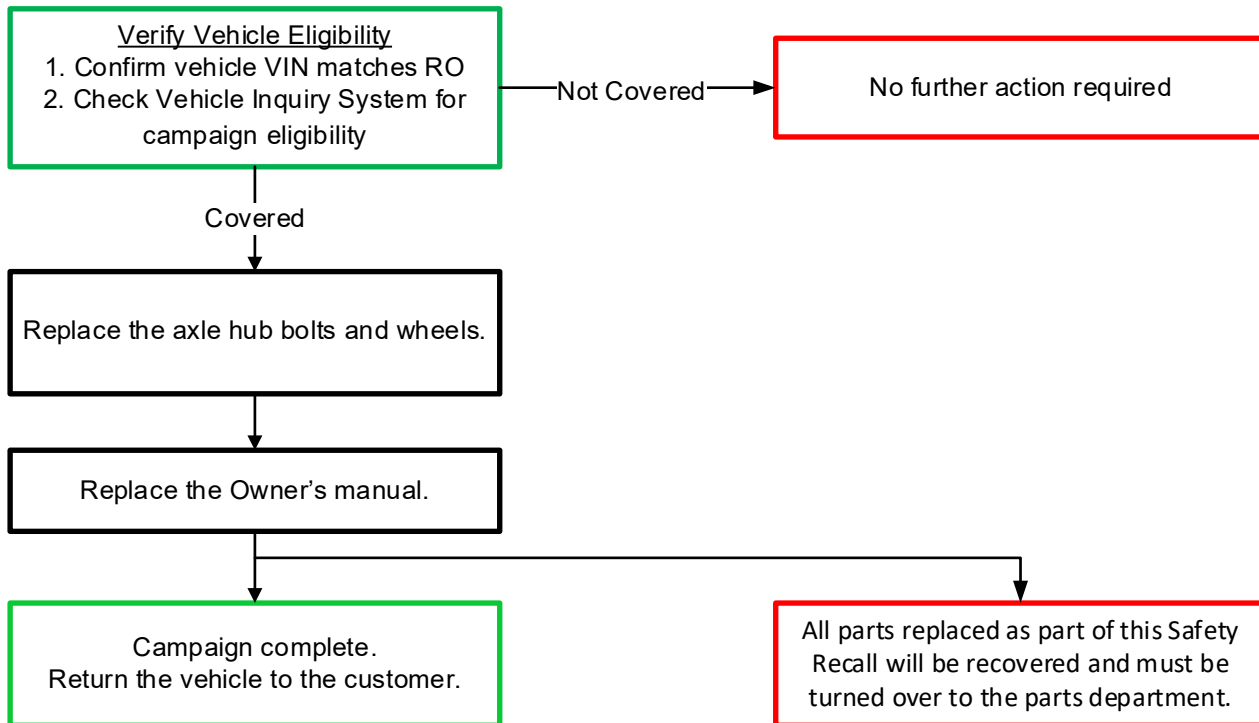

II. IDENTIFICATION OF AFFECTED VEHICLES

1. CHECK VEHICLE FOR CAMPAIGN ELIGIBILITY

- Compare the vehicles VIN to the VIN listed on the Repair Order to ensure they match.
- Check the TIS Vehicle Inquiry System to confirm the VIN is involved in this Campaign, and that it has not already been completed.

NOTICE:

TMNA warranty will not reimburse dealers for repairs completed on vehicles that are not affected or were previously completed, even by another dealer.

III. PREPARATION

A. PARTS

Part Number	Part Description	Quantity
04002-25142	WHEEL, DISC (18-inch)	4
Part Number	Part Description	Quantity
04002-25242	WHEEL, DISC (20-inch)	4
Part Number	Part Description	Quantity
04002-32142	BOLT, AXLE HUB*	1
* The kit above includes the following parts.		
Part Number	Part Name	Quantity
90942-02101	BOLT, HUB (FOR AXLE)	20
Part Number	Part Description	Quantity
90942-A5005	VALVE, TIRE PRESSURE MONITOR	4
Part Number	Part Description	Quantity
-	OWNER'S MANUAL*	1

*Owner's Manual will be shipped directly to the dealer ATTN service manager for all confirmed vehicles at their location.

B. TOOLS, SUPPLIES & EQUIPMENT

- Standard Hand Tools
- Car Tire Balancer
- Torque Wrench
- Tire Fitting Equipment
- Tire Pressure Gauge
- Torx Socket Wrench T10

SST – These are essential special service tools that the dealership should have.

Part Number	Part Description	Quantity
09650-53010	One Touch Wheel Guide Pin	1

C. MATERIALS

- Protective Gloves
- Marker
- Protective Glasses
- Soapy Water or Equivalent
- Protective Tape

IV. BACKGROUND

After low-mileage use, all of the hub bolts on a wheel on the subject vehicles can loosen to the point where the wheel can detach from the vehicle. If a wheel detaches from the vehicle while driving, it could result in a loss of vehicle control, increasing the risk of a crash. **No one should drive these vehicles until the remedy is performed.**

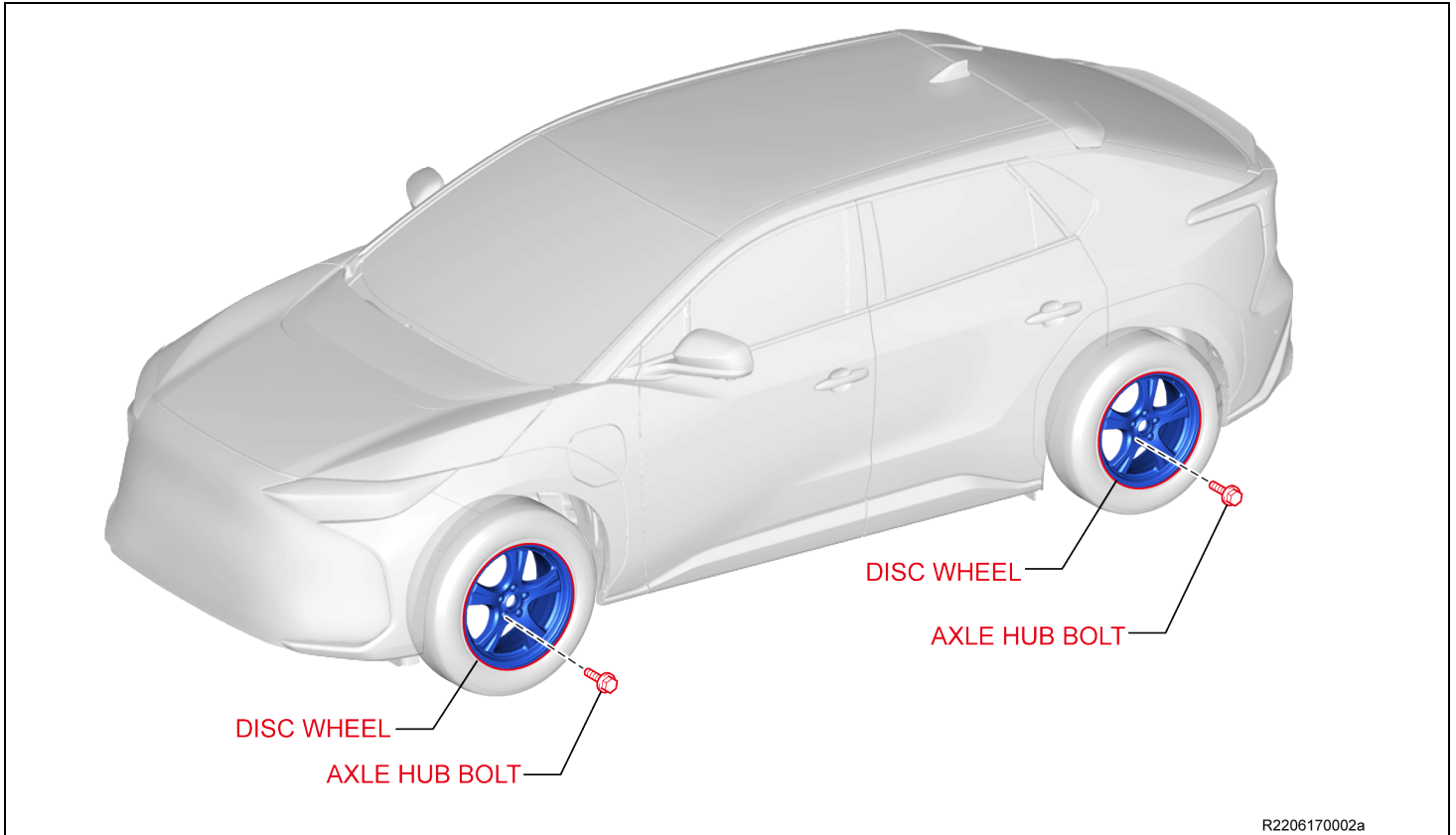

V. COMPONENTS

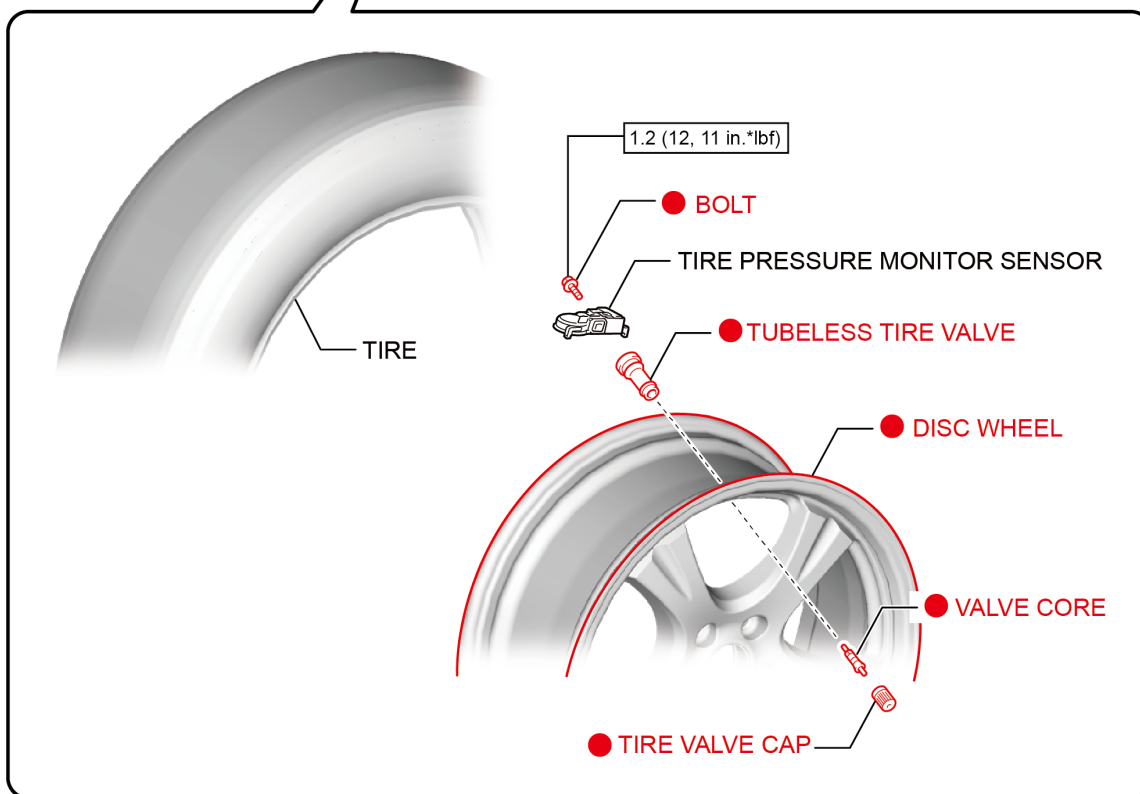
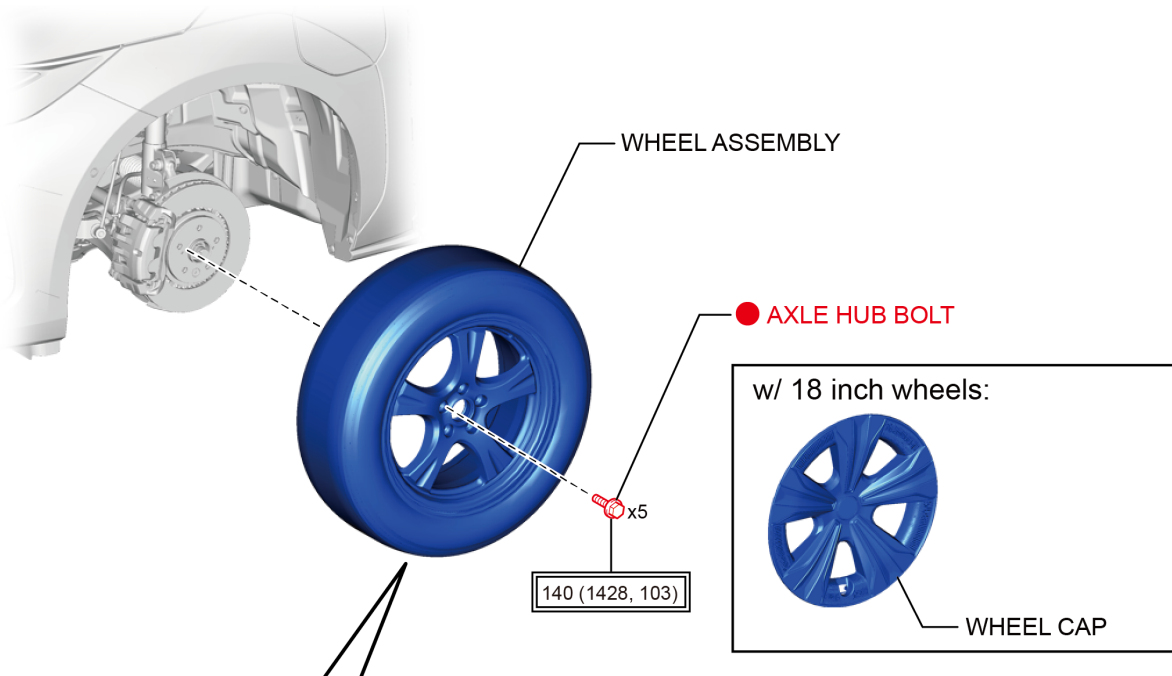

● : Replacement part

$N \cdot m$ (kgf*cm, ft.*lbf) : Specified torque

$N \cdot m$ (kgf*cm, ft.*lbf) : Tightening torque for "Major areas involving basic vehicle performance such as moving/turning/stopping"

R2208090012a

HINT:

The illustration shown is LH front side of 18inch aluminum wheel specification.

VI. REPLACE WHEEL AND HUB BOLT

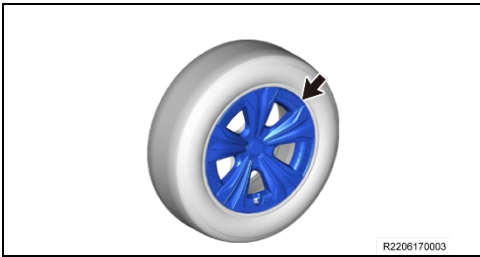

1. REMOVE THE WHEEL CAP (w/ 18 inch wheels)

- a) Remove the wheel cap.

2. RECORD THE TIRE MOUNTING POSITIONS

- a) Before removing the wheel and tire assembly from the vehicle, use tape marked with the wheel position on the vehicle. (e.g., right front = RF, right rear = RR, etc.).

HINT:

- If the TPMS is not installed in its original position, the pressure displayed on the multi-information display will not be displayed correctly.
- In the unlikely event that the original position of the TPMS is no longer known, it is necessary to record the ID number of the tire pressure warning valve and transmitter and register it to the vehicle ECU. (For the procedure, refer to the repair manual.)

3. MARK THE OLD WHEELS



- The new wheels and old wheels have the same shape and cannot be distinguished.
- Be sure to mark the old wheels (surface of bolt holes) before removing the wheel assembly from the vehicle so that you can tell the new ones and old ones apart.
- Make sure not to reinstall the old parts.



- a) As shown in the illustration, mark the wheel and middle of the axle hub bolt head (indented part) before removing the wheel assemblies from vehicle.



For 20-inch aluminum wheels, **DO NOT** let paint contact the wheel cap or wheel hub ornament sub-assemblies since they are to be reused.

4. REMOVE THE TIRE w / WHEEL

[Refer to TIS for instructions on Suspension / TIRE / WHEEL / TIRE AND WHEEL / REMOVAL.](#)

HINT:

Use SST or Wheel Guide Pin (0915B-53010) to facilitate alignment of wheel assembly with the axle hub bolt hole and to prevent the wheel assembly from falling.

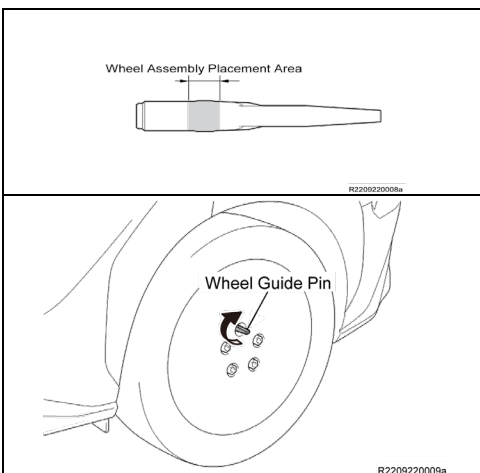

- a) How to use the provided Wheel Guide Pin

- (1) Remove the axle hub bolt which is at the 12 o'clock position and install the wheel guide pin turning it clockwise by hand.
- (2) Remove the remaining 4 axle hub bolts, and remove the wheel assembly.

5. REMOVE WHEEL CAP SUB-ASSEMBLY AND WHEEL HUB ORNAMENT SUB-ASSEMBLY (w/ 20-inch wheels)

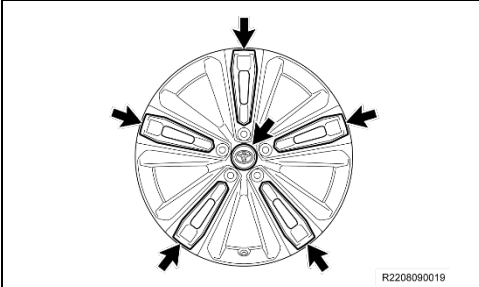

- Place a moving blanket or protective blanket on the work bench.
 - Place the wheel face down so the back side of the wheel is exposed.
 - Remove the wheel cap sub-assembly and the 5 wheel hub ornament sub-assemblies by releasing the claws on the backside of the wheel.
- Hint: Placing the wheel face down will prevent wheel hub ornaments from falling or dropping during removal.



6. REMOVE THE TIRE AND THE TIRE PRESSURE WARNING VALVE AND TRANSMITTER

- Remove the tires.

[Refer to TIS for instructions on Suspension / TIRE PRESSURE MONITORING / TIRE PRESSURE WARNING VALVE / REMOVAL.](#)

7. INSTALL THE TIRE PRESSURE WARNING VALVE AND TRANSMITTER



- Always use a **NEW** bolt, tubeless tire valve, valve core and tire valve cap when installing the tire pressure warning valve and transmitter.
- Make sure not to damage the urethane covered backside of the tire pressure warning valve and transmitter (the surface opposite to the side with the ID code) with anything sharp.

8. INSTALL TIRE AND BALANCE WHEEL ASSEMBLY

- Reinstall the removed tires to the **NEW** wheels.

[Refer to TIS for instructions on Suspension / TIRE PRESSURE MONITORING / TIRE PRESSURE WARNING VALVE / INSTALLATION.](#)

HINT:

The positions of the tire pressure warning valve and transmitter when they are set on the mounting machine are indicated in the repair manual, but they may differ with the recommended positions depending on the specifications of the mounting machine being used. Perform this work using the standard work methods that suit the equipment environment at the dealer so that the tire pressure warning valve and transmitter are not interfered with.



- When markings were forgotten, tires were rotated, etc., the “tire position write” procedure is necessary. Before installing the tires, write down the transmitter ID of the tire pressure warning valve and transmitter.
- Check that there is no oil, water or lubricant around the rim hole, tire pressure warning valve and transmitter. Failing to do so may result in improper installation.
- Use only a specified tire valve cap. If an unspecified tire valve cap is used, it may seize to the tire pressure warning valve and transmitter.
- Make sure that the tire pressure warning valve and transmitter is installed so that the printed surface can be seen. If the tire pressure warning valve and transmitter is installed upside down, it may be damaged or fail to transmit signals when driving at high speeds.
- Check that there is no deformation or damage to the tire pressure warning valve and transmitter.
- Check that there is no foreign matter on the grommet and around the rim hole.
- **DO NOT** apply soapy water or equivalent directly to the tire pressure warning valve and transmitter.
- Make sure that the tire bead and mount tool **DO NOT** interfere with the tire pressure warning valve and transmitter.
- Make sure that the tire pressure warning valve and transmitter is not clamped by the bead and rim.

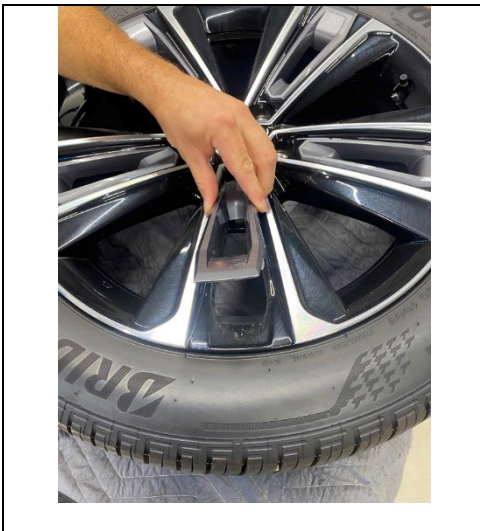

9. INSTALL WHEEL CAP SUB-ASSEMBLY AND WHEEL HUB ORNAMENT SUB-ASSEMBLY (w/ 20 inch wheels)

- a) Install the wheel cap sub-assembly and 5 wheel hub ornament sub-assemblies that were removed from the old wheels.

10. HOW TO DISTINGUISH THE AXLE HUB BOLTS

Critical

- The new axle hub bolt has a washer and an O-ring which keep the washer from falling off.
- The bolt head flange has 3 ribs so that the new and old bolts can be distinguished even when they are installed on the wheels.
- Check the difference between the new and old bolts to make sure the old bolts are not reinstalled.

HINT:

The length of the 3 ribs on the bolt head is slightly different depending on the manufacturer.

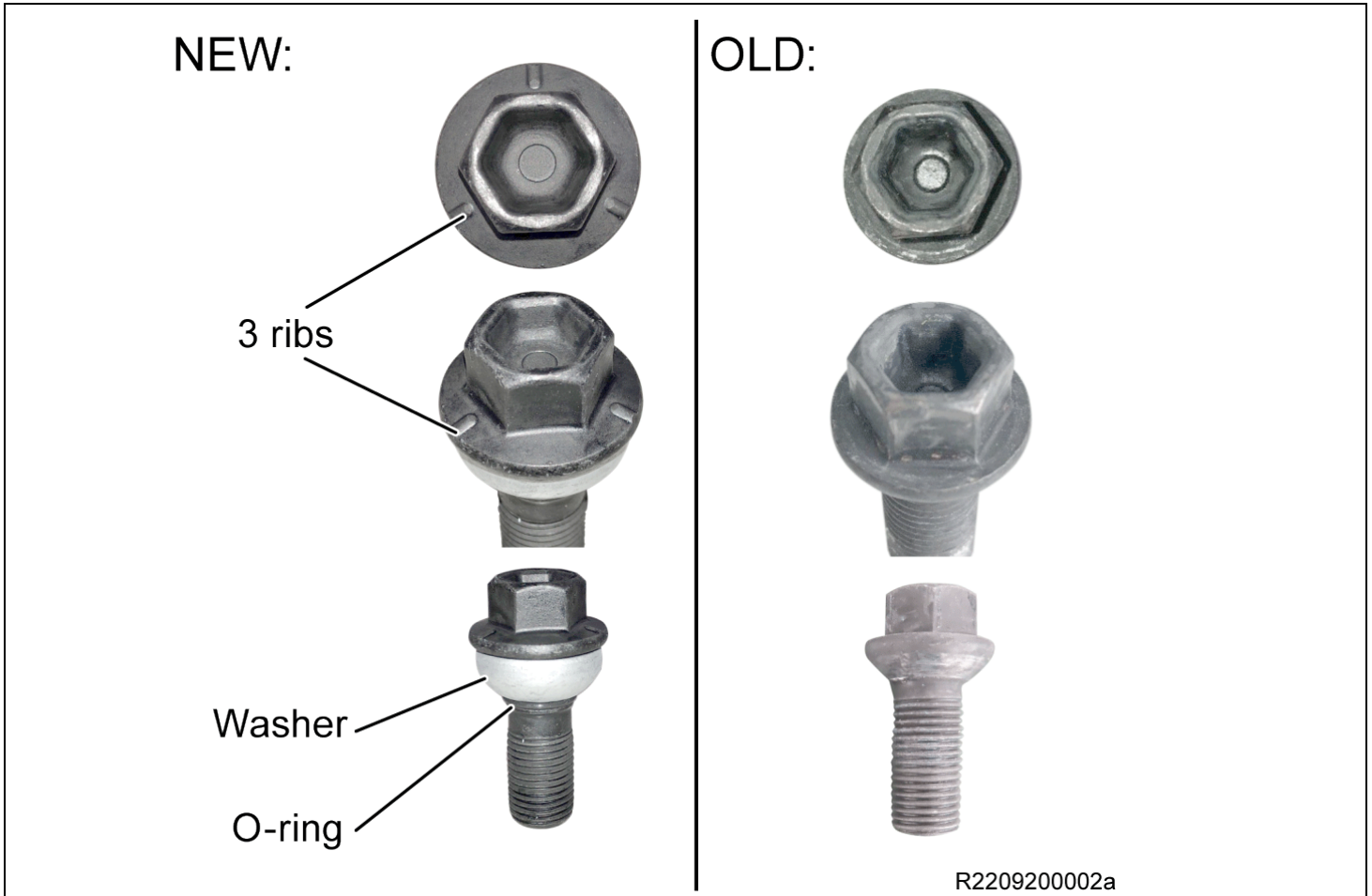

a) Confirm the axle hub bolts are **NEW** ones.

Critical

- If the vehicle was equipped with accessory locking hub bolts these will not be reused and will be recovered along with the old hub bolts.

b) CHECK AXLE HUB BOLT O-RING STATE

- (1) Check the O-rings for damage, deterioration (chips, scratches, cracks, fissures, fractures) and bite-in of foreign matter.

Standard: There is no damage, deterioration and bite-in of foreign matter

HINT:

- If there is any foreign matter, clean and remove.
- When cleaning, **DO NOT** disassemble the axle hub bolt or damage the O-ring.
- If there is any damage or deterioration, replace the axle hub bolt with a new one.

- (2) Check the O-ring is properly installed.

Standard: The O-ring is installed to the O-ring groove

HINT:

Ensure the O-ring is installed in the O-ring groove on the bolt as shown, if the O-ring is missing or damaged replace the axle hub bolt with a new one.

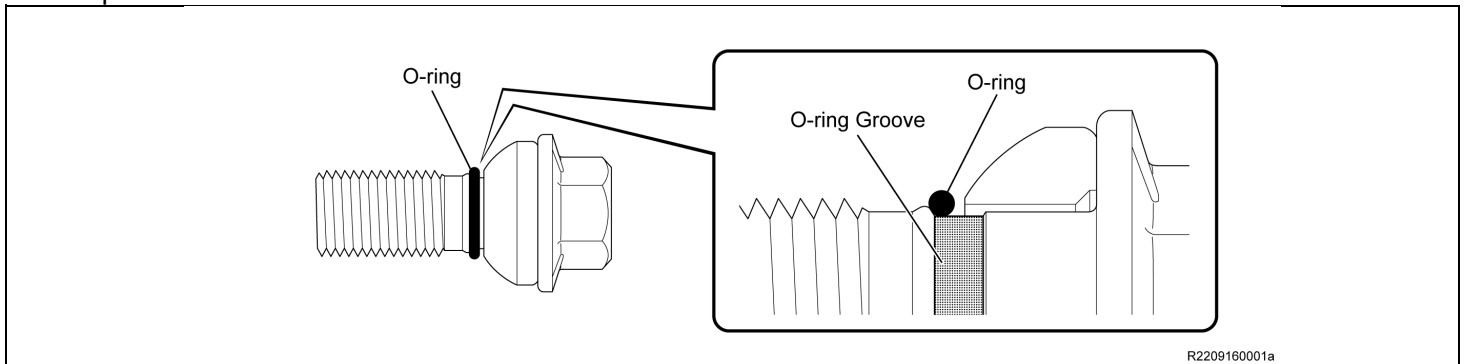

11. INSTALL THE TIRE w/ WHEEL

[Refer to TIS for instruction on Suspension / TIRE / WHEEL / TIRE AND WHEEL / INSTALLATION.](#)

Torque: 140 N*m (1428 kgf*cm, 103 ft.*lbf)



- Check that there is no foreign matter or rust on the axle hub bolt hole threads and the contact surfaces of the wheel, brake disc, axle hub, etc. Clean the contact surfaces and axle hub bolts if necessary. If a wheel assembly is installed with foreign matter or rust between the contact surfaces, the foreign matter or rust may work loose. This may result in a reduction of the fastening force (axial force) leading to looseness or loss of one or more axle hub bolts.
- When installing the axle hub bolts, check that the axle hub bolts rotate smoothly by hand. If the axle hub bolts do not rotate smoothly, check that there is no foreign matter or rust and clean if necessary.

HINT:

Use SST or Wheel Guide Pin (0915B-53010) to facilitate alignment of wheel assembly with the axle hub bolt hole and to prevent the wheel assembly from falling.

12. ADJUST THE TIRE AIR PRESSURE



Adjust the tire air pressure after lowering the lift. If the pressure is adjusted while the vehicle is on the lift, and then the vehicle is lowered to the ground, the air pressure will change slightly due to a change in volume, and the meter display value may be offset.

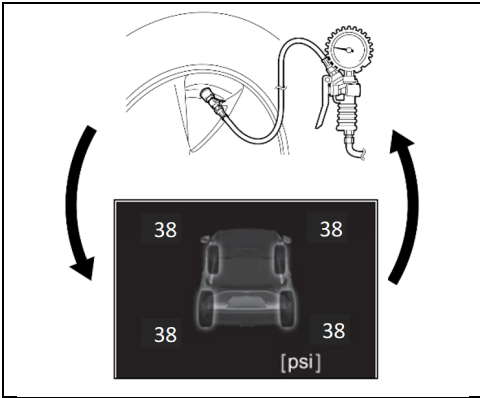

- a) Turn to READY On, and press the steering switch to display "Tire Pressure [kPa]" on the multi-information display.
- b) Adjust the tire inflation pressure to the specified value checking the values shown on tire pressure gauge and multi-information display.

Cold Tire Inflation Pressure:
38 psi (260 kPa , 2.7 kgf/cm²,)

HINT:

If the tire inflation pressure is not displayed and "---" is shown, the transmitter may be damaged. Inspect the transmitter according to the repair manual.

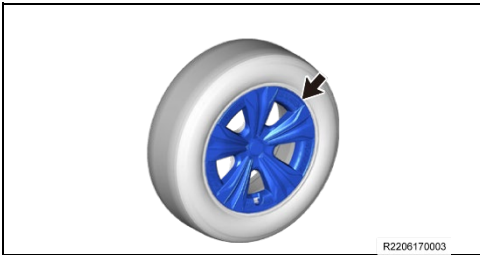

13. REINSTALL THE WHEEL CAP (w/ 18 inch wheels)

- a) Align the position of the tubeless tire valve and wheel cap hole, and then install the wheel cap.

Critical Make sure to align the position of tubeless tire valve and wheel cap hole, otherwise the tubeless tire valve may be damaged.

VII. REPLACE THE OWNER'S MANUAL

1. REPLACE OWNER'S MANUAL WITH UPDATED OWNER'S MANUAL

- a) Apply a mark to the recovered Owner's Manual and then discard it.

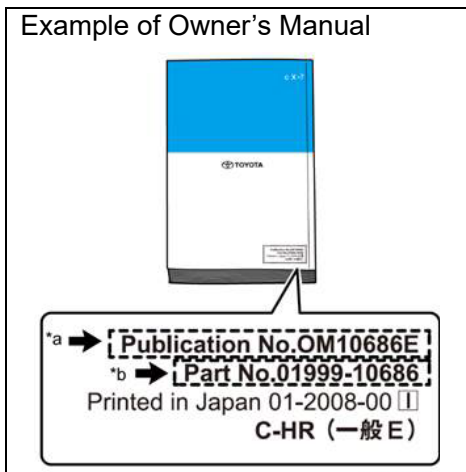

HINT: Updated Owner's Manual will have the following information
 Publication No. OM42G17U
 Part No. 01999-42G17

◀ VERIFY REPAIR QUALITY ▶

- Confirm all hub bolts are torqued properly to: **140 N*m (1428 kgf*cm, 103 ft.*lbf)**
- Confirm the multi-information display can show the tire pressure for all four tires.
 - Confirm new Owner's Manual is in the glove box.

VIII. APPENDIX

A. PARTS DISPOSAL

As required by Federal Regulations, please make sure all recalled parts (original parts) removed from the vehicle are disposed of in a manner in which they will not be reused, ***unless requested for parts recovery return.***

B. CAMPAIGN DESIGNATION DECODER

