

# SAFETY RECALL

NORTH AMERICA

## High Pressure Fuel Pump



Reference: Z46 / NHTSA 22V-406

FCA US LLC



Remedy available for

2014 - 2020 (WK) Jeep Grand Cherokee



**RAM**

Remedy available for

2014 - 2019 (DS) RAM 1500 Pickup

Template Version 1.0

Revision	Edition	Detail
4	March 2024	Parts information is updated.

### SYMPTOM DESCRIPTION

The High-Pressure Fuel Pump (HPFP) on about 138,640 of the above vehicles may fail prematurely. A HPFP failure may introduce internally failed component debris into the fuel system potentially causing fuel starvation. Vehicle occupants may notice a Malfunction Indicator Lamp illuminating, a fuel leak, abnormal engine noise, or a change in drive quality. Fuel starvation may result in an unexpected loss of motive power, which can cause vehicle crash without prior warning.

### SCOPE

This recall applies only to the above vehicles equipped with a 3.0L engine (sales codes EXF and EXN).

NOTE: Some vehicles above may have been identified as not involved in this recall and therefore have been excluded from this recall.

### IMPORTANT:

- Some of the involved vehicles may be in dealer new vehicle inventory. Federal law requires you to complete this recall service on these vehicles before retail delivery. Violation of this requirement by a dealer could result in a civil penalty of up to \$27,168 per vehicle.
- Some of the involved vehicles may be in dealer used vehicle inventory. Dealers should complete this recall service on these vehicles before retail delivery.
- Dealers should also perform this recall on vehicles in for service.

Involved vehicles can be determined by using the VIP inquiry process.

### REPAIR TO BE PERFORMED

Vehicles delivered to the dealer in good running condition should complete HPFP replacement only. See Service Procedure A (non-contaminated system).

If the vehicle is brought to the dealer not running, the technician will follow the current diagnostic procedure to determine if there was an HPFP failure. If HPFP failure was determined, replacement of both the HPFP and fuel pump module is required, including fuel system cleaning. See Service Procedure B (contaminated system).

### ALTERNATE TRANSPORTATION

Dealers should attempt to minimize customer inconvenience by placing the owner in a loaner vehicle if inspection determines that HPFP replacement is required, and the vehicle must be held overnight.

# SAFETY RECALL

NORTH AMERICA

## High Pressure Fuel Pump



Reference: Z46 / NHTSA 22V-406

FCA US LLC

### COMPLETION REPORTING / REIMBURSEMENT

Claims for vehicles that have been serviced must be submitted on the DealerCONNECT Claim Entry Screen located on the Service tab. Claims paid will be used by FCA to record recall service completions and provide dealer payments.

Use the following labor operation numbers and time allowances:

Labor Description	Number	Hrs
Replace High Pressure Fuel Pump and Fuel Tubes and fuel filters (WK)	14-Z4-61-82	2.2
Clean Fuel Tank, Replace In-Tank Fuel Modules, Fuel Filters, Fuel Injectors, Fuel Rails, HP Fuel Tubes, and HP Fuel Pump (WK)	14-Z4-61-83	7.8
Replace High Pressure Fuel Pump and Fuel Tubes and fuel filter (DS)	14-Z4-61-82	1.9
Clean Fuel Tank, Replace In-Tank Fuel Modules, Fuel Filters, Fuel Injectors, Fuel Rails, HP Fuel Tubes, and HP Fuel Pump (DS)	14-Z4-61-83	5.9

Labor Description	Number	Allowance
Floor Plan Reimbursement	95-95-95-97	Calculate See Below

Floor Plan Reimbursement represents the vehicle's average daily allowance (see table below) multiplied by the number of days the vehicle was in dealer inventory and not available for sale. This reimbursement is limited to the number of days from the date of the stop sale to the date that the remedy was made available. Note: If the vehicle was received by your dealership (KZX date) AFTER the stop sale date, you will use the KZX date instead of the stop sale date. For this Recall, the stop sale was initiated on **06/16/2022**. The **WK** remedy was made available on **01/04/2024**, therefore the number of days cannot exceed **567** days. The **DS** remedy was made available on **2/29/2024**, therefore the number of days cannot exceed **623** days.

Vehicle	Average Daily Allowance
2014 – 2020 (WK) Jeep Grand Cherokee	██████
2014 – 2019 (DS) RAM 1500 Pickup	██████

Add the cost of the recall parts package plus applicable dealer allowance to your claim.

In addition, enter "MATL" in the Part Number section of your claim with the applicable Material Allowance where appropriate.

**NOTE:** See the Warranty Administration Manual, Recall Claim Processing Section, for complete recall claim processing instructions.

# SAFETY RECALL

NORTH AMERICA

## High Pressure Fuel Pump



Reference: Z46 / NHTSA 22V-406

FCA US LLC

### PARTS INFORMATION

Part No.	Qty.	Part Name
<b>WK PARTS</b>		
<b>ORDER THESE PARTS FOR NON-CONTAMINATED WK VEHICLES (NO HPFP FAILURE)</b>		
CSSMZ461AA	1	High Pressure Fuel Pump
CSSMZ46EAA	1	Tube Kit and EGR Gaskets
	1	GASKET - UPPER EGR TUBE
	1	RUBBER GASKET - UPPER EGR TUBE
	4	TUBE - FUEL INJECTOR SUPPLY
CSSMZ463AA	1	FUEL/WATER SEPARATOR KIT
04275086AE	1	AUTHORIZED MODIFICATION (LABEL)
CSFP01A1AA	1	SEE ORDERING INFORMATION BELOW THIS TABLE. (Contaminated and Non-Contaminated Vehicle)
	1	Owner's Manual Addendum
	1	Tip Card
	1	Fuel Door Decal

### Process Steps to Order Campaign kit CSFP01A1AA:

1. Access the “DealerCONNECT” website.
2. Select the “Marketing” link in the header of DealerCONNECT.
3. Locate the “Product Information” section heading on the Marketing page.
4. Select the “Literature and Merchandising Materials” link in the product information section.
5. Locate the “MOPAR” section heading on the Literature and Merchandising Materials page.
6. Select the “Recall Labels / Cards” link listed in the MOPAR section.
7. Select **Item > Update Cart > Submit Order.**

Part No.	Qty.	Part Name
<b>WK PARTS</b>		
<b>ORDER THESE PARTS FOR CONTAMINATED WK VEHICLES (WITH HPFP FAILURE)</b>		
CSSMZ461AA	1	High Pressure Fuel Pump
68334956AA	1	Tube Kit
68211302AA	6	Fuel Injectors with NAS (50 state emissions)
CSSMZ465AA	6	Injector O-ring
	1	Fuel Rail Right
	1	Fuel Rail Left
	1	O-ring Fuel Pump Module
	1	Tube -fuel Injector supply (left) (NOT USED)
	4	Bolt and Washer, Driveshaft
	3	Bolt and Washer, Driveshaft
	2	Stud and Washer, Driveshaft
	1	Pickup Unit Level Module
CSGNZ961AA	1	Gasket, EGR Upper Tube
	1	Rubber Gasket, Upper EGR Tube
CSSMZ467AA	1	<b>Fuel Pump (2011-2015)</b>
	1	Fuel Pump Level Unit (Module)
	1	O-ring, Fuel Pump Module
CSSMZ468AA	1	<b>Fuel Pump (2016-2020)</b>
	1	Module Kit – Fuel Pump
	1	O-ring, Fuel Pump Module
CSSMZ463AA	1	Fuel/Water Separator Kit
55398183AA	1	Clamp, Tailpipe
04275086AE	1	AUTHORIZED MODIFICATION (LABEL)
CSFP01A1AA	1	SEE ORDERING INFORMATION BELOW

Strictly respect STELLANTIS Group safety, cleanliness, and environmental instructions for any vehicle service. Document exclusively reserved for dealer information. Internal distribution to be ensured by dealer. Reproduction forbidden without the written agreement of STELLANTIS Group. (C) 2023 STELLANTIS Group. All Rights Reserved

(dit)

# SAFETY RECALL

NORTH AMERICA

## High Pressure Fuel Pump



Reference: Z46 / NHTSA 22V-406

FCA US LLC

Part No.	Qty.	Part Name
		THIS TABLE. (Contaminated and Non-Contaminated Vehicle)
	1	Owner's Manual Addendum
	1	Tip Card
	1	Fuel Door Decal

### Process Steps to Order Campaign kit CSFP01A1AA:

1. Access the “**DealerCONNECT**” website.
2. Select the “**Marketing**” link in the header of DealerCONNECT.
3. Locate the “**Product Information**” section heading on the Marketing page.
4. Select the “**Literature and Merchandising Materials**” link in the product information section.
5. Locate the “**MOPAR**” section heading on the Literature and Merchandising Materials page.
6. Select the “**Recall Labels / Cards**” link listed in the MOPAR section.
7. Select **Item > Update Cart > Submit Order**.

# SAFETY RECALL

NORTH AMERICA

## High Pressure Fuel Pump



Reference: Z46 / NHTSA 22V-406

FCA US LLC

Part No.	Qty.	Part Name
<b>DS PARTS</b>		
<b>ORDER THESE PARTS FOR NON-CONTAMINATED DS VEHICLES (NO HPFP FAILURE)</b>		
CSSMZ461AA	1	High Pressure Fuel Pump
CSSMZ46EAA	1	Tube Kit and EGR Gaskets GASKET - UPPER EGR TUBE
	1	RUBBER GASKET - UPPER EGR TUBE
	4	TUBE - FUEL INJECTOR SUPPLY
CSSMZ462AA	1	FUEL/WATER SEPARATOR KIT
04275086AE	1	AUTHORIZED MODIFICATION (LABEL)
CSFP01A1AA	1	SEE ORDERING INFORMATION BELOW THIS TABLE. (Contaminated and Non-Contaminated Vehicle)
	1	Owner's Manual Addendum
	1	Tip Card
	1	Fuel Door Decal

Part No.	Qty.	Part Name
<b>DS PARTS</b>		
<b>ORDER THESE PARTS FOR CONTAMINATED DS VEHICLES (WITH HPFP FAILURE)</b>		
CSSMZ461AA	1	High Pressure Fuel Pump
CSSMZ46DAA	6	Injector O-ring
	6	Fuel Injectors
	1	Fuel Rail Right
	1	Fuel Rail Left
	1	O-ring Fuel Pump Module
	1	Fuel Pump Module
CSGNZ961AA	1	Gasket, EGR Upper Tube
	1	Rubber Gasket, Upper EGR Tube
CSSMZ462AA	1	Fuel/Water Separator Kit
68334956AA	1	Tube Kit (9 tubes)
04275086AE	1	AUTHORIZED MODIFICATION (LABEL)
CSFP01A1AA	1	SEE ORDERING INFORMATION BELOW THIS TABLE. (Contaminated and Non-Contaminated Vehicle)
	1	Owner's Manual Addendum
	1	Tip Card
	1	Fuel Door Decal

### Process Steps to Order Campaign kit CSFP01A1AA:

1. Access the “DealerCONNECT” website.
2. Select the “Marketing” link in the header of DealerCONNECT.
3. Locate the “Product Information” section heading on the Marketing page.
4. Select the “Literature and Merchandising Materials” link in the product information section.
5. Locate the “MOPAR” section heading on the Literature and Merchandising Materials page.
6. Select the “Recall Labels / Cards” link listed in the MOPAR section.
7. Select **Item > Update Cart > Submit Order**.

### Process Steps to Order Campaign kit CSFP01A1AA:

1. Access the “DealerCONNECT” website.
2. Select the “Marketing” link in the header of DealerCONNECT.
3. Locate the “Product Information” section heading on the Marketing page.
4. Select the “Literature and Merchandising Materials” link in the product information section.
5. Locate the “MOPAR” section heading on the Literature and Merchandising Materials page.

Strictly respect STELLANTIS Group safety, cleanliness, and environmental instructions for any vehicle service.  
 Document exclusively reserved for dealer information. Internal distribution to be ensured by dealer.  
 Reproduction forbidden without the written agreement of STELLANTIS Group. (C) 2023 STELLANTIS Group. All Rights Reserved

(dit)

# SAFETY RECALL

NORTH AMERICA

## High Pressure Fuel Pump



Reference: Z46 / NHTSA 22V-406

FCA US LLC

6. Select the “**Recall Labels / Cards**” link listed in the MOPAR section.
7. Select **Item > Update Cart > Submit Order**.

### PARTS RETURN

No parts return required for this campaign.

Render the recalled HPFP unusable and discard.

### SPECIAL TOOLS

Number	Description
NPN	wiTECH MicroPod II / MDP
NPN	Laptop Computer
NPN	wiTECH Software
VM.10345	Tool, High Pressure Pump Installation
1023	Puller (Originally Shipped in Kit Number(s) 8678)
APS35IB	Blue Point Spanner Wrench or equivalent
2025400090	Remover-Installer, Fuel Rail Bolt
VM.10358A	Remover, Fuel Injector
9717	Brush, Injector Bore (Originally Shipped in Kit Number 9910)
8978A	Decay Tool, Fuel
9340	SAE Fuel Pump Lock Ring Wrench (Originally Shipped In Kit Number(s) 9327, 9327CC, 9397, 9575)

### DEALER NOTIFICATION

To view this notification on DealerCONNECT, select “Global Recall System” on the Service tab, then click on the description of this notification.

### OWNER NOTIFICATION / SERVICE SCHEDULING

All involved vehicle owners known to FCA are being notified of the service requirement by first class mail. They are requested to schedule appointments for this

service with their dealers. A generic copy of the owner letter is attached.

### VEHICLE LISTS, GLOBAL RECALL SYSTEM, VIP AND DEALER FOLLOW UP

All involved vehicles have been entered into the DealerCONNECT Global Recall System (GRS) and Vehicle Information Plus (VIP) for dealer inquiry as needed.

GRS provides involved dealers with an updated VIN list of their incomplete vehicles. The owner’s name, address and phone number are listed if known. Completed vehicles are removed from GRS within several days of repair claim submission.

To use this system, click on the “**Service**” tab and then click on “**Global Recall System**.” Your dealer’s VIN list for each recall displayed can be sorted by those vehicles that were unsold at recall launch, those with a phone number, city, zip code, or VIN sequence.

**Dealers must perform this repair on all unsold vehicles before retail delivery.** Dealers should also use the VIN list to follow up with all owners to schedule appointments for this repair.

*Recall VIN lists may contain confidential, restricted owner name and address information that was obtained from the Department of Motor Vehicles of various states. Use of this information is permitted for this recall only and is strictly prohibited from all other use.*

### ADDITIONAL INFORMATION

If you have any questions or need assistance in completing this action, please contact your Service and Parts District Manager.

Customer Services / Field Operations  
FCA US LLC.

# SAFETY RECALL

NORTH AMERICA

## High Pressure Fuel Pump



Reference: Z46 / NHTSA 22V-406

FCA US LLC

### SERVICE PROCEDURE - WK

For vehicles with a non-contaminated fuel system, use the procedure below.

#### A. Replace HPFP – Non-Contaminated System

**WARNING:** Observe the following precautions when working on fuel systems: No sparks, open flames or smoking. Avoid inhaling and swallowing fuel. Avoid eye and skin contact with fuel. Pour fuels only into suitable and appropriately marked containers. Wear protective clothing. Failure to observe these precautions may result in fire, explosion, property damage, and serious or fatal injury.

**WARNING:** High-pressure fuel lines deliver fuel under extreme pressure from the injection pump to the injectors. This may be as high as 1800 bar (26,106 psi). Use extreme caution when inspecting for high-pressure fuel leaks. Inspect high-pressure fuel leaks with a sheet of cardboard. Wear safety goggles and adequate protective clothing when servicing fuel system. Fuel under this amount of pressure can penetrate skin causing serious or fatal injury.

**NOTE:** The fuel injection pump can be replaced without having to perform the entire base engine valve timing procedure. This procedure gives instruction on how to remove and install the new fuel injection pump without performing the base engine timing. Do not rotate the pump shaft after removing from the vehicle. The alignment of the pump shaft must be measured and recorded using a commercially available degree wheel after the pump is removed and before transferring the pump gear over to the new pump. This is done to align the pump to the same position during installation. If the base engine valve timing must be performed as part of the repair, refer to Service Library 09 - Engine/Valve Timing/Standard Procedure.

**NOTE:** When key is cycled to the off position, fuel system pressure automatically bleeds down.

1. Cycle the ignition to the Off position. Be certain that all electrical accessories are turned off.
2. Position the passenger front seat forward.

**NOTE:** Shown with seat removed for clarity.

3. Remove the battery cover (1) (Figure 1).

**NOTE:** If equipped with an Intelligent Battery Sensor (IBS), disconnect the IBS connector first before disconnecting the negative battery cable.

4. Disconnect and isolate the negative battery cable from the battery.

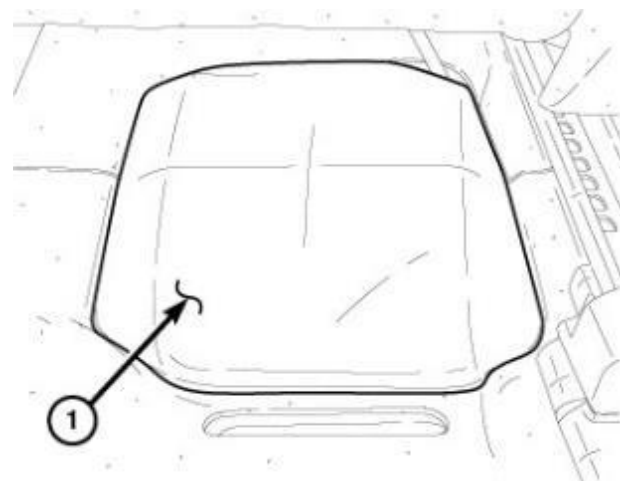


Figure 1 – Battery Cover

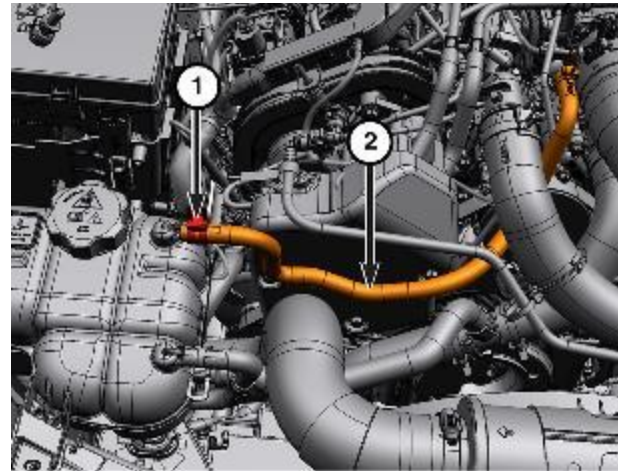
**SAFETY RECALL**  
NORTH AMERICA  
**High Pressure Fuel Pump**



Reference: Z46 / NHTSA 22V-406

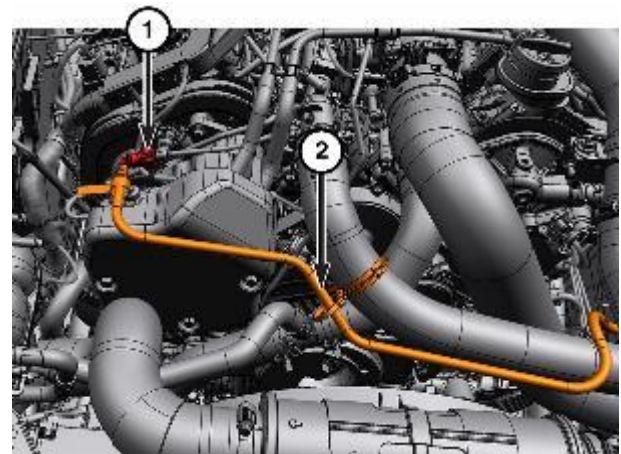
FCA US LLC

5. Release the hose clamp (1) and set the degas hose (2) aside (Figure 2).



**Figure 2 – Degas Hose**

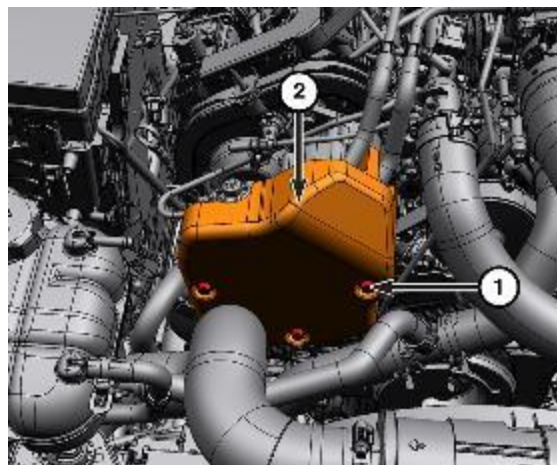
6. Disconnect the quick-connect fitting (1) and set the vacuum line (2) aside (Figure 3).



**Figure 3 – Vacuum Line**



7. Remove the screws (1) that secure the cover (2) for the high-pressure fuel pump (Figure 4).



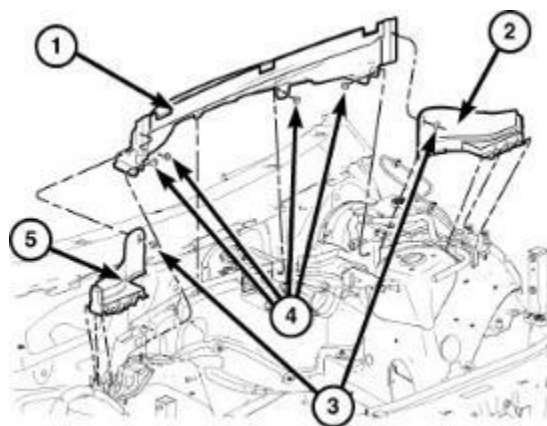
**Figure 4 – Cover Screws**

8. Remove the engine cover (1) (Figure 5).



**Figure 5 – Engine Cover**

9. Remove the cowl extension (1) and the side extensions (2, 5) (Refer to 23 - Body/Exterior/SILENCER, Cowl Extension/Removal) (Figure 6).



**Figure 6 – Cowl Extension and Side Extensions**

# SAFETY RECALL

NORTH AMERICA

## High Pressure Fuel Pump

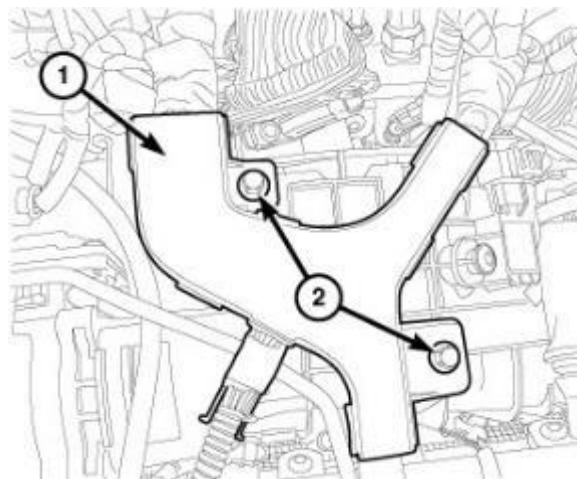


Reference: Z46 / NHTSA 22V-406

FCA US LLC

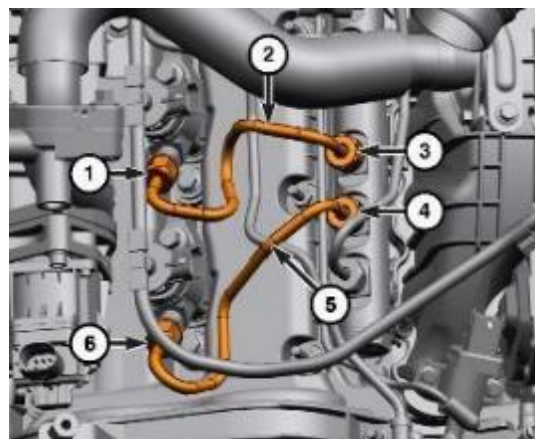
10. Remove the bolts (2) and pull up on the engine wire harness assembly (1) to release retainers from the intake manifold (Figure 7).

**NOTE: Use a backing wrench on the fuel injector when unscrewing the union nut.**



**Figure 7 – Engine Wiring Harness**

11. Remove and discard the right-side fuel tubes (5, 2) from fuel injectors No. 1 and 2 (Figure 8).



**Figure 8 – Right-Side Fuel Tubes Wiring Harness**

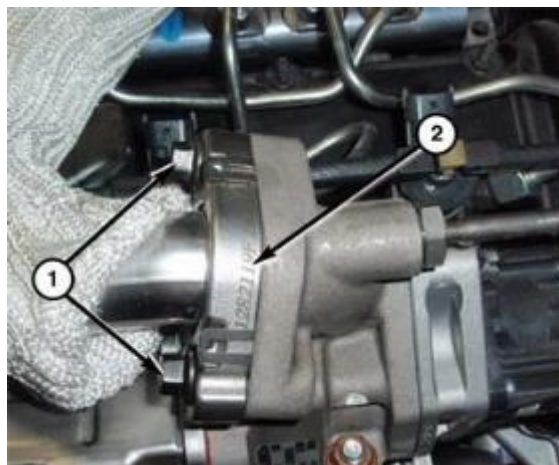
**SAFETY RECALL**  
NORTH AMERICA  
**High Pressure Fuel Pump**



Reference: Z46 / NHTSA 22V-406

FCA US LLC

12. Remove the upper EGR tube bolts (1) (Figure 9) and (2) (Figure 10).
13. Remove and discard both gaskets.



**Figure 9 – Upper EGR Tube Bolts**



**Figure 10 – Upper EGR Tube Bolts at Intake**

# SAFETY RECALL

NORTH AMERICA

## High Pressure Fuel Pump



Reference: Z46 / NHTSA 22V-406

FCA US LLC

14. Remove the nut (1) securing the fuel tube (Figure 11).
15. Remove the union nuts (2, 4) and the right high pressure fuel tube (3), discard the fuel tube (Figure 11).
16. Remove the bolt (9) securing the left side fuel tube (11) to EGR air flow control valve (Figure 11).
17. Loosen the union nuts (10, 12) and remove the left high pressure fuel tube (11), discard the fuel tube (Figure 11).
18. Install protective caps to the fuel injectors and fuel rails.
19. Disconnect the low-pressure fuel supply lines (3) (Figure 12).
20. Disconnect the fuel quantity solenoid wire harness connector (2) (Figure 12).

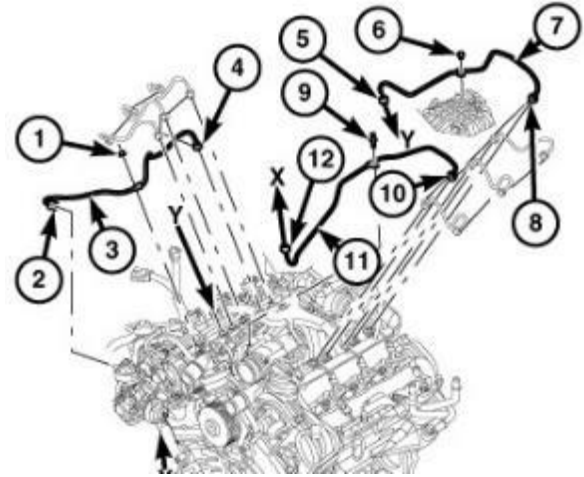


Figure 11 – Fuel Tube Nut

**NOTE: The fuel injection pump can be replaced without having to perform the entire base engine valve timing procedure. This procedure gives instruction on how to remove and install the new fuel injection pump without performing the base engine timing. Do not rotate the pump shaft after removing from the vehicle. The alignment of the pump shaft must be measured and recorded using a commercially available degree wheel after the pump is removed and before transferring the pump gear over to the new pump. This is done to align the pump to the same position during installation. If the base engine valve timing must be performed as part of the repair, refer to Service Library 09 - Engine/Valve Timing/Standard Procedure.**

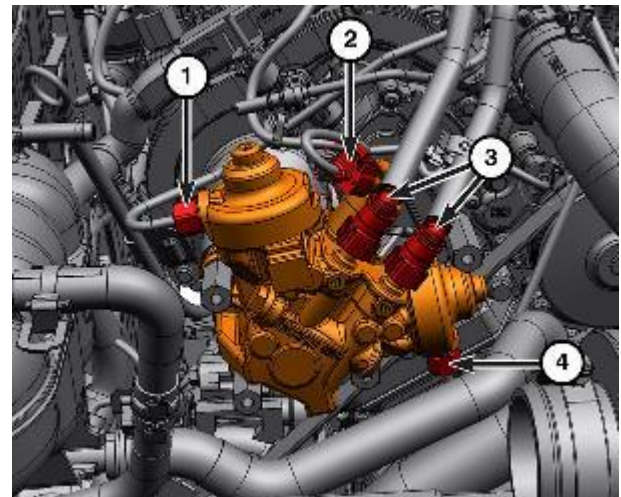


Figure 12 – HPFP Connections

# SAFETY RECALL

NORTH AMERICA

## High Pressure Fuel Pump

Reference: Z46 / NHTSA 22V-406



FCA US LLC

21. Remove the upper bolts (1) from the high-pressure pump (2) (Figure 13).
22. Using Tool, High Pressure Pump Installation VM.10345 Install the studs in the upper locations.

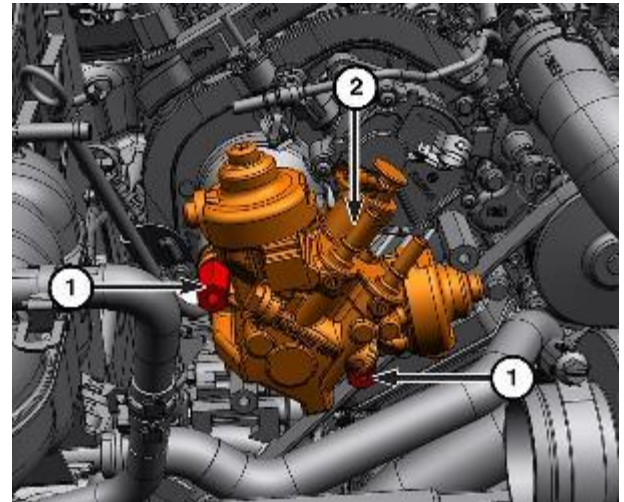


Figure 13 – Upper HPFP Bolts

23. Remove the lower bolt (1) from the HPFP and remove it from the vehicle (Figure 14).

**NOTE: The fuel injection pump needs to be timed using a commercially available degree wheel.**

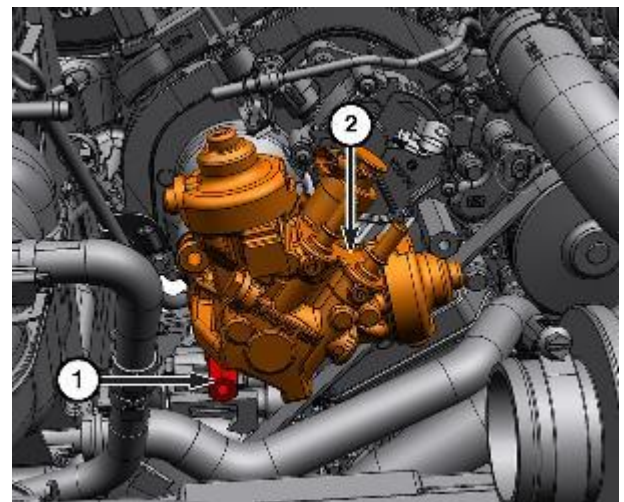


Figure 14 – Lower HPFP Bolt

# SAFETY RECALL

NORTH AMERICA

## High Pressure Fuel Pump

Reference: Z46 / NHTSA 22V-406



FCA US LLC

24. Install the degree wheel onto the pump with the zero at the fuel quantity solenoid then mark the location of the hole in the gear on the degree wheel (Figure 15).



**Figure 15 – Installing a Printed Paper Degree Wheel from the Internet**

25. Using a commercially available spanner wrench such as Blue Point APS351B, Snap-on APS351C or equivalent (2) to hold fuel injection pump gear. Remove the fuel injection pump gear nut (1) (Figure 16).



**Figure 16 – Spanner Wrench and Drive Gear on the HPFP**

## SAFETY RECALL

NORTH AMERICA

### High Pressure Fuel Pump

Reference: Z46 / NHTSA 22V-406



FCA US LLC

26. The use of Puller 1023 or a commercially available gear puller is required to remove the fuel injection pump gear (2) (Figure 17).

**WARNING:** High-pressure lines deliver diesel fuel under extreme pressure from the injection pump to the fuel injectors. This may be as high as 2000 bar (29,008 psi). Use extreme caution when inspecting for high-pressure fuel leaks. Fuel under this amount of pressure can penetrate skin causing personal injury or death. Inspect for high-pressure fuel leaks with a sheet of cardboard. Wear safety goggles and adequate protective clothing when servicing fuel system.

**WARNING:** Observe the following precautions when working on fuel systems: No sparks, open flames or smoking. Avoid inhaling and swallowing fuel. Avoid eye and skin contact with fuel. Pour fuels only into suitable and appropriately marked containers. Wear protective clothing. Failure to observe these precautions may result in fire, explosion, property damage, and serious or fatal injury.

**CAUTION:** Do Not Force the high-pressure pump into the right timing cover or attempt to seat it by drawing it in with the bolts. The pump gear must be properly aligned with the drive gear on the camshaft before the high-pressure pump will seat on the cylinder head mounting surface. Failure to properly align drive gears will damage the high-pressure pump or camshaft drive gear.

**NOTE:** The high-pressure pump needs to be timed before it can be installed. Use a commercially available degree wheel to time the high-pressure pump.

**NOTE:** The fuel injection pump can be replaced without having to perform the entire base engine valve timing procedure. This procedure gives instruction on how to remove and install the new fuel injection pump without performing the base engine timing. Do not rotate the pump shaft after removing from the vehicle. The alignment of the pump shaft must be measured and recorded using a commercially available degree wheel after the pump is removed and before transferring the pump gear over to the new pump. This is done to align the pump to the same position during installation. If the base engine valve timing must be performed as part of the repair, refer to Service Library 09 - Engine/Valve Timing/Standard Procedure.

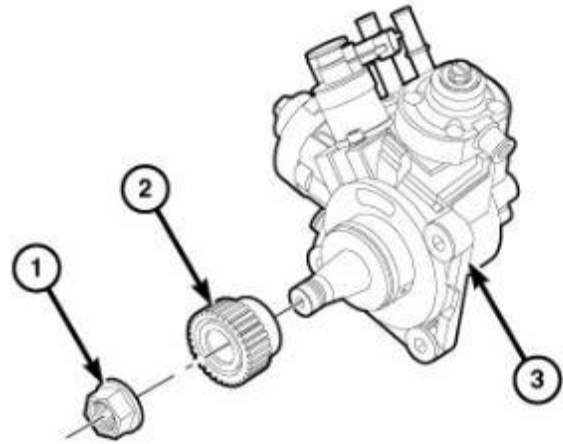


Figure 17 – Removing the Drive Gear on the HPFP

# SAFETY RECALL

NORTH AMERICA

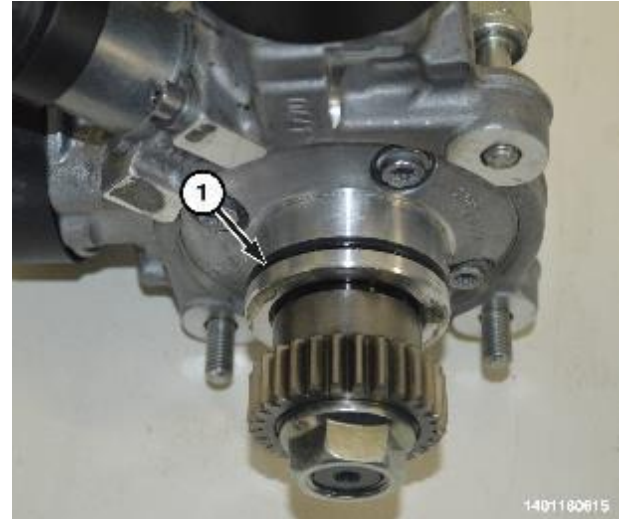
## High Pressure Fuel Pump



Reference: Z46 / NHTSA 22V-406

FCA US LLC

27. Install a **NEW** O-ring seal (1) to the high-pressure fuel injection pump (Figure 18).
28. Install the gear (2) and **NEW** nut (1) onto the **NEW** high-pressure pump (3) and tighten the nut (1) finger tight (Figure 17).
29. Using a commercially available spanner wrench (2) such as Blue Point APS35IB or equivalent to hold the pump, tighten the nut (1) to 50 N·m (37 Ft. Lbs.) (Figure 16).
30. Install the degree wheel with the zero in line with the fuel quantity solenoid and rotate the pump shaft so that the hole aligns with the reference mark on the degree wheel referenced during the removal (Figure 15).



**Figure 18 – HPFP O-ring Seal**

31. Install the HPFP onto the Tool, High Pressure Pump Installation VM.10345 installed in the upper timing cover.
32. Install the HPFP (2) and hand tighten the bolt (1) (Figure 14).
33. Remove the Tool, High Pressure Pump Installation VM.10345 from the upper bolts location and install the bolts (Figure 13).
34. Tighten the bolts (1) that secure the fuel injection pump to 25 N·m (18 Ft. Lbs.).
35. Connect the fuel injection pump electrical connector (2) (Figure 11).
36. Connect the low-pressure fuel supply and return lines (3) (Figure 11).
37. Remove the protective caps from the fuel injectors and fuel rail.

**NOTE: Fuel tubes are a onetime only use and must be replaced anytime they have been removed.**

38. Install the **NEW** left high-pressure fuel tube (11) and tighten the union nuts (10, 12) finger tight (Figure 11):
  - Tighten the union nut (10) to 5 N·m (44 in. lbs.) plus an additional 75 degrees turn.
  - Tighten the union nut (12) to 11 N·m (8 ft. lbs.) plus an additional 75 degrees turn.
39. Install the bolt (9) securing the left side high pressure fuel tube (11) to EGR air flow control valve and tighten to 11 N·m (8 ft. lbs.) (Figure 11).
40. Install the **NEW** right high-pressure fuel tube (3) and tighten union nuts (2, 4) finger tight (Figure 11):
  - Tighten the union nut (4) to 5 N·m (44 in. lbs.) plus an additional 75 degrees turn.
  - Tighten the union nut (2) to 11 N·m (8 ft. lbs.) plus an additional 75 degrees turn.



**SAFETY RECALL**  
NORTH AMERICA  
**High Pressure Fuel Pump**



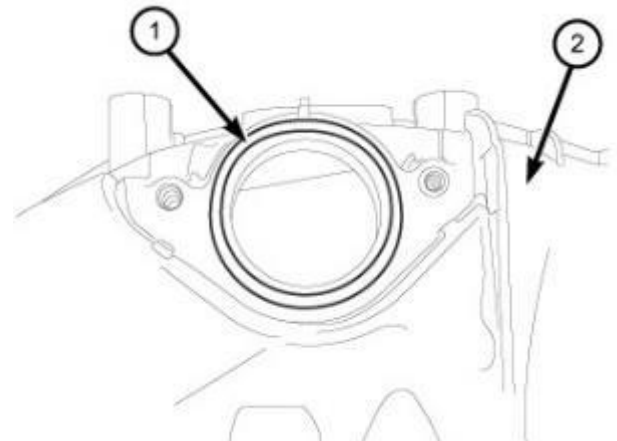
Reference: Z46 / NHTSA 22V-406

FCA US LLC

41. Install the nut (1) securing the right-side high-pressure fuel tube (3) to right side cylinder head cover and tighten to 11 N·m (8 ft. lbs.) (Figure 11).

**NOTE: Use a backing wrench on the fuel injector when tightening the union nut.**

42. Install the **NEW** right-side fuel tubes (5, 2) to the fuel injectors No. 1 and 2 and tighten the union nuts finger tight (Figure 8).
  - Tighten the union nut (3 & 4) to 5 N·m (44 in. lbs.) plus an additional 75 degrees turn.
  - Tighten the union nut (1 & 6) to 11 N·m (8 ft. lbs.) plus an additional 75 degrees turn.
43. Install the engine wire harness assembly (1) to the intake manifold and push down to seat the wire harness retainers. Tighten the bolts (2) to 11 N·m (8 ft. lbs.) (Figure 7).
44. Clean all upper EGR tube gasket sealing areas.
45. Install a **NEW** O-ring gasket (1) onto the intake manifold (2) (Figure 19).



**Figure 19 – Upper EGR Tube O-ring at Intake Manifold**

# SAFETY RECALL

NORTH AMERICA

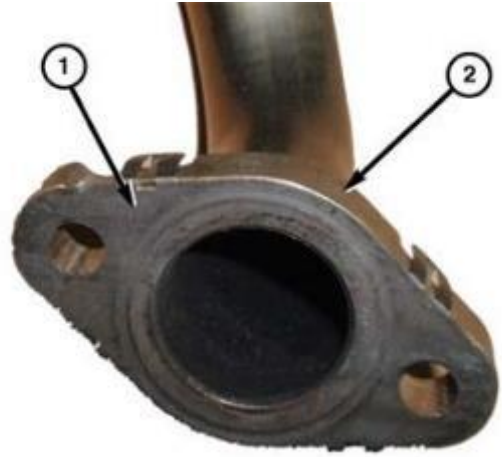
## High Pressure Fuel Pump

Reference: Z46 / NHTSA 22V-406

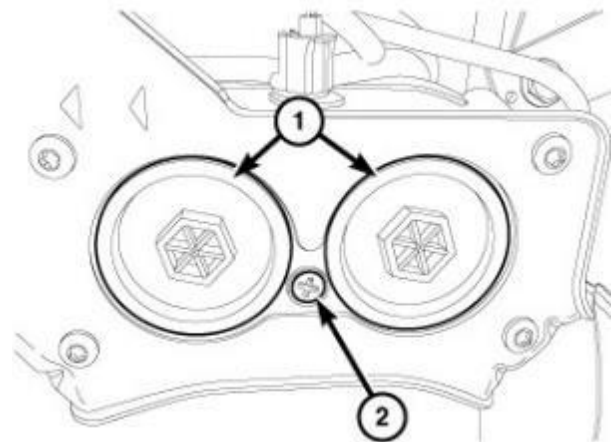


FCA US LLC

46. Install a **NEW** EGR tube gasket (1) (Figure 20).
47. Install the EGR tube (1) to the intake manifold. Tighten the bolts (2) to 11 N·m (8 ft. lbs.) (Figure 10).
48. Install the EGR tube bolts (1) and tighten to 25 N·m (18 ft. lbs.) (Figure 9).
49. Install the fuel injection pump cover (2) and tighten the screws (1) securely (Figure 4).
50. Set the vacuum line (2) in place and connect the quick-connect fitting (1) (Figure 3).
51. Set the degas hose (2) in place and secure the hose clamp (1) (Figure 2).
52. Raise the vehicle.
53. Remove the transmission skid plate (Refer to 13 - Frame and Bumpers/Under Body Protection/PLATE, Skid - Removal).
54. Loosen the drain plug (2) and drain the diesel fuel into a suitable container (Figure 21).
55. Securely tighten the drain plug (2).

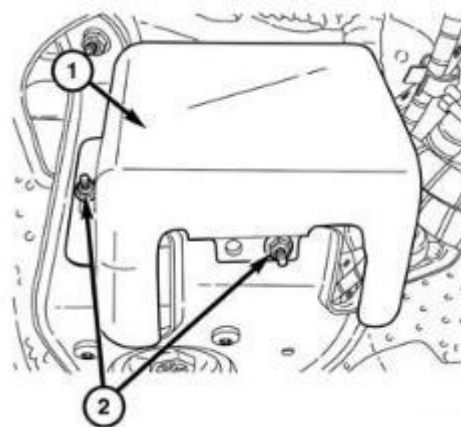


**Figure 20 – Upper EGR Tube Gasket**



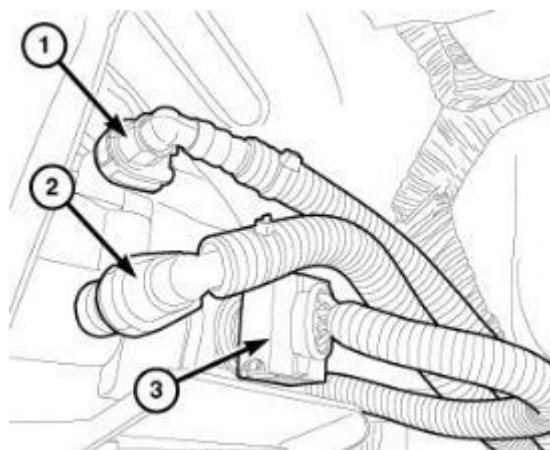
**Figure 21 – Drain Plug**

56. Remove the nuts (2) and the fuel filter shield (1) (Figure 22).



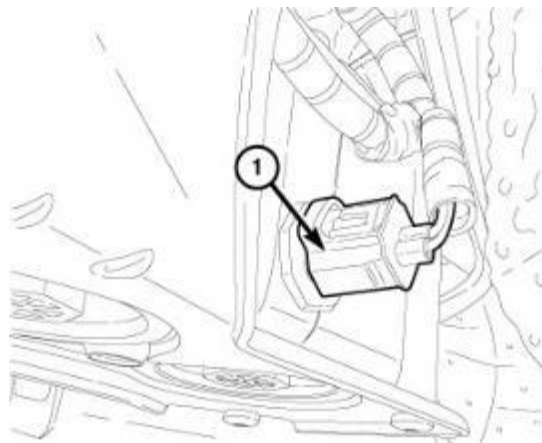
**Figure 22 – Fuel Filter Shield**

57. Disconnect the fuel filter/water separator outlet fuel line (1) (Figure 23).
58. Disconnect the fuel filter/water separator inlet fuel line (2) (Figure 23).
59. Disconnect the combination fuel heater/temperature sensor wire harness connector (3) (Figure 23).



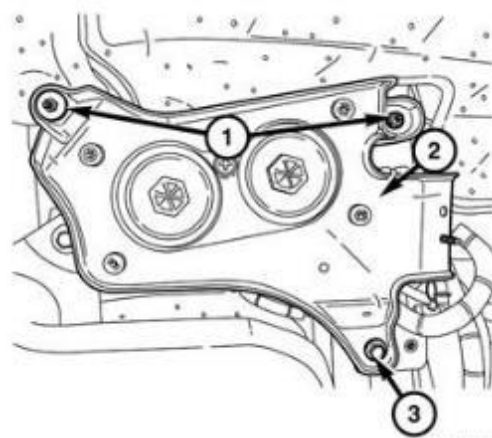
**Figure 23 – Inlet and Outlet Lines**

60. Disconnect the Water In Fuel (WIF) sensor wire harness connector (1) (Figure 24).



**Figure 24 – WIF Sensor Connector**

61. Remove the nuts (1), bolt (3), and the fuel filter/water separator assembly (2) (Figure 25).



**Figure 25 – Fuel Filter/Water Separator**

**SAFETY RECALL**  
NORTH AMERICA  
**High Pressure Fuel Pump**



Reference: Z46 / NHTSA 22V-406

FCA US LLC

- 62. Clean the outside of the housing. Remove and discard each fuel filter cover and the fuel filter element from the bottom of the fuel filter/water separator (Figure 26).



**Figure 26 – Remove Old Filter Covers and Elements**

- 63. From the top of the fuel filter/water separator, remove the cover (Figures 27 & 28).



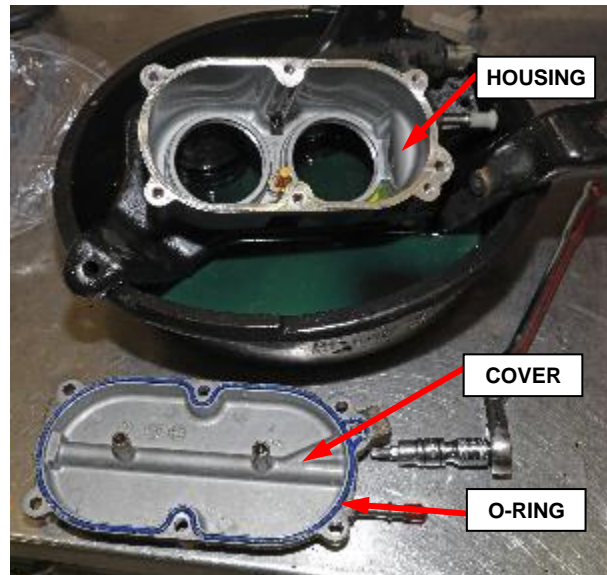
**Figure 27 – Remove Fuel Filter/Water Separator Cover**

**SAFETY RECALL**  
NORTH AMERICA  
**High Pressure Fuel Pump**



Reference: Z46 / NHTSA 22V-406

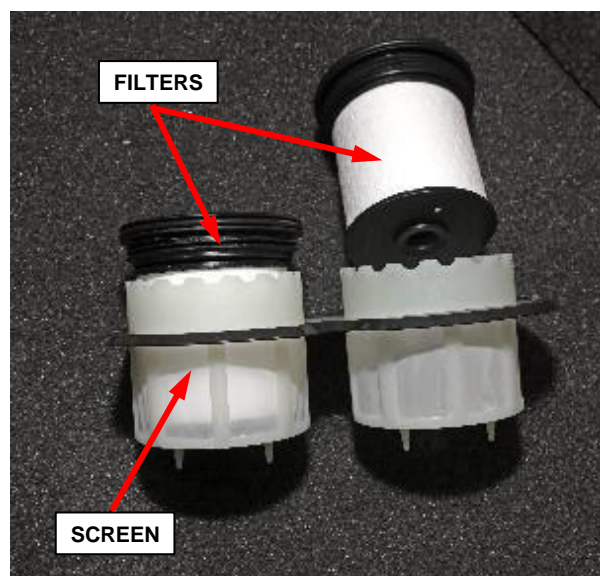
FCA US LLC



**Figure 28 – Fuel Filter/Water Separator Cover Removed**

**NOTE: The NEW Fuel Filter Kit contains two filter elements, a cover O-ring (not shown) and a filter screen (Figure 29)**

64. Thoroughly clean the inside of the housing and cover.



**Figure 29 – New Fuel Filter Kit**

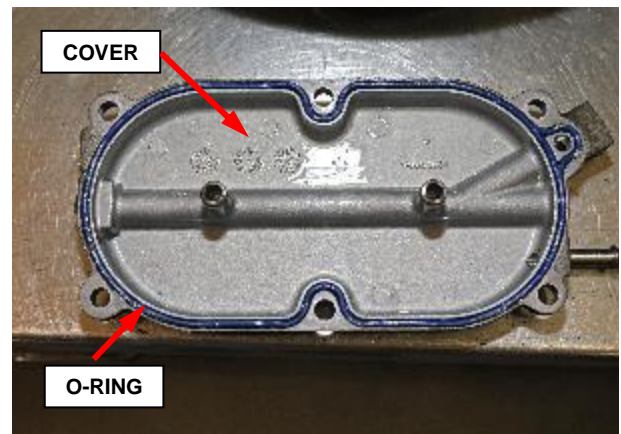
**SAFETY RECALL**  
NORTH AMERICA  
**High Pressure Fuel Pump**



Reference: Z46 / NHTSA 22V-406

FCA US LLC

65. Remove and discard the old cover O-ring. Lubricate the **NEW** seal with clean diesel and install it into the channel in the cover (Figure 30).



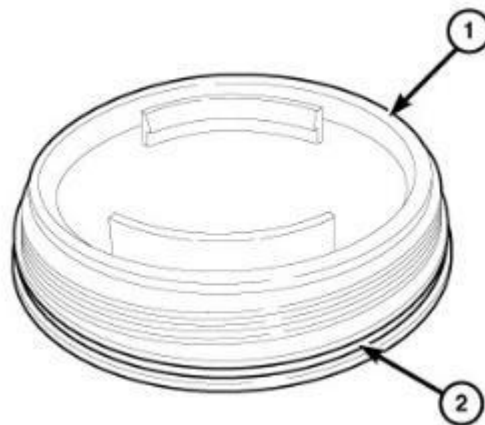
**Figure 30 – Cover O-ring**

66. Install the **NEW** screen into the housing as shown in Figure 58. Check that the screen is fully and evenly seating into the housing (Figure 31).
67. Install the cover. Apply fresh Loctite 270 or equivalent to the cover screws and tighten to 24 N-m (18 ft. lbs.).



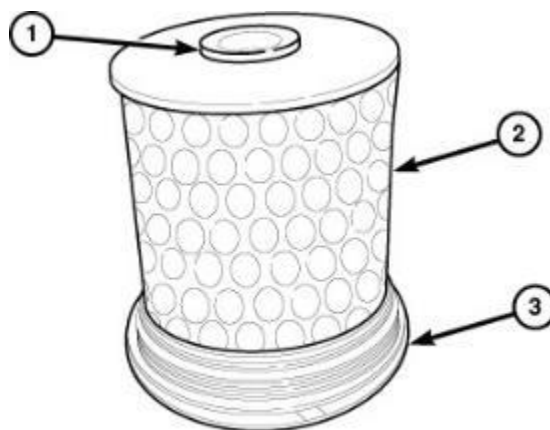
**Figure 31 – Screen Installed**

68. Lubricate the **NEW** O-ring seal (2) on filter covers (1) with clean diesel (Figure 32).



**Figure 32 – Filter Cover O-ring**

69. Position and push down on **NEW** fuel filters (2) to install filter onto the cover (3) (Figure 33).
70. Lubricate the rubber seal (1) with clean diesel fluid (Figure 33).



**Figure 33 – Filter Seal**



# SAFETY RECALL

NORTH AMERICA

## High Pressure Fuel Pump

Reference: Z46 / NHTSA 22V-406



FCA US LLC

71. Install each fuel filter. Tighten each cover (1) to 20 N·m (15 ft. lbs.) (Figure 34).
72. Install the fuel filter/water separator assembly (2) to the vehicle. Tighten the two nuts (1), and one bolt (3) to 20 N·m (15 ft. lbs.) (Figure 25).
73. Connect the Water In Fuel (WIF) sensor wire harness connector (1) (Figure 24).
74. Connect the combination fuel heater/temperature sensor wire harness connector (3) (Figure 23).
75. Connect the fuel filter/water separator inlet fuel line (2) (Figure 23).
76. Connect the fuel filter/water separator outlet fuel line (1) (Figure 23).
77. Install the fuel filter shield (1). Tighten the nuts (2) 14 N·m (10 ft. lbs.) (Figure 22).
78. Lower the vehicle.
79. Connect the negative battery cable to the battery.



**Figure 34 – Filters Installed**

- NOTE: If equipped with an Intelligent Battery Sensor (IBS), connect the IBS connector after connecting the negative battery cable.**
80. Prime the fuel system (Refer to 14 - Fuel System/Fuel Delivery/Standard Procedure).
  81. Start engine, allow to warm, turn engine off. Check and verify there are no leaks (Refer to 14 - Fuel System/Fuel Delivery, Diesel/Tube(s), Fuel/Diagnosis and Testing).
  82. Install the cowl extension (1) and the side extensions (2, 5) (Refer to 23 - Body/Exterior/SILENCER - Installation) (Figure 6).
  83. Install the engine cover (1) (Figure 5).
  84. Install the battery cover (1) (Figure 1).

# SAFETY RECALL

NORTH AMERICA

## High Pressure Fuel Pump



Reference: Z46 / NHTSA 22V-406

FCA US LLC

### SERVICE PROCEDURE - WK

For vehicles with a contaminated fuel system, use the procedure below.

#### B. Replace HPFP – Contaminated System

**WARNING:** Observe the following precautions when working on fuel systems: No sparks, open flames or smoking. Avoid inhaling and swallowing fuel. Avoid eye and skin contact with fuel. Pour fuels only into suitable and appropriately marked containers. Wear protective clothing. Failure to observe these precautions may result in fire, explosion, property damage, and serious or fatal injury.

**WARNING:** High-pressure fuel lines deliver fuel under extreme pressure from the injection pump to the injectors. This may be as high as 1800 bar (26,106 psi). Use extreme caution when inspecting for high-pressure fuel leaks. Inspect high-pressure fuel leaks with a sheet of cardboard. Wear safety goggles and adequate protective clothing when servicing fuel system. Fuel under this amount of pressure can penetrate skin causing serious or fatal injury.

**NOTE:** The fuel injection pump can be replaced without having to perform the entire base engine valve timing procedure. This procedure gives instruction on how to remove and install the new fuel injection pump without performing the base engine timing. Do not rotate the pump shaft after removing from the vehicle. The alignment of the pump shaft must be measured and recorded using a commercially available degree wheel after the pump is removed and before transferring the pump gear over to the new pump. This is done to align the pump to the same position during installation. If the base engine valve timing must be performed as part of the repair, refer to Service Library 09 - Engine/Valve Timing/Standard Procedure.

**NOTE:** When key is cycled to the off position, fuel system pressure automatically bleeds down.

1. Cycle the ignition to the Off position. Be certain that all electrical accessories are turned off.
2. Position the passenger front seat forward.

**NOTE:** Shown with seat removed for clarity.

3. Remove the battery cover (1) (Figure 21).

**NOTE:** If equipped with an Intelligent Battery Sensor (IBS), disconnect the IBS connector first before disconnecting the negative battery cable.

4. Disconnect and isolate the negative battery cable from the battery.

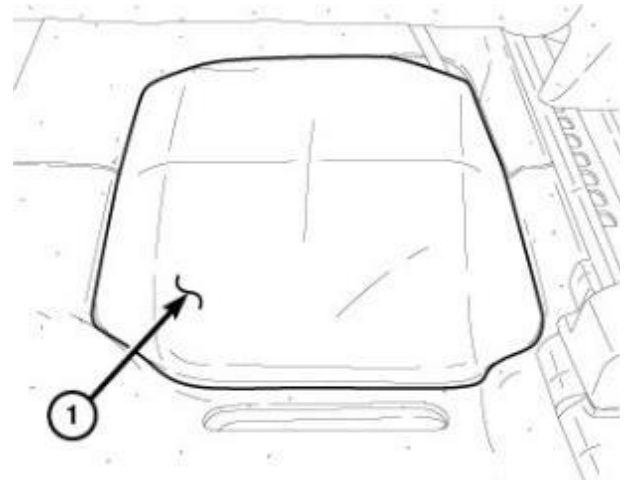


Figure 21 – Battery Cover

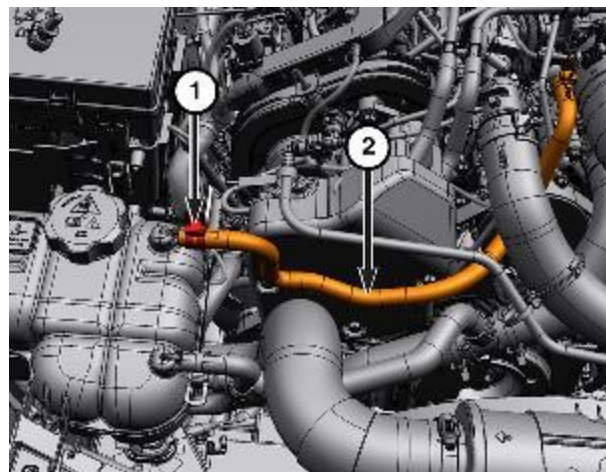
**SAFETY RECALL**  
NORTH AMERICA  
**High Pressure Fuel Pump**



Reference: Z46 / NHTSA 22V-406

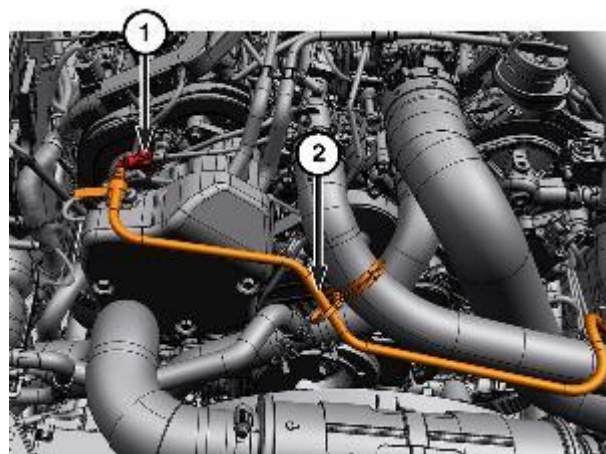
FCA US LLC

5. Release the hose clamp (1) and set the degas hose (2) aside (Figure 22).



**Figure 22 – Degas Hose**

6. Disconnect the quick-connect fitting (1) and set the vacuum line (2) aside (Figure 23).



**Figure 23 – Vacuum Line**

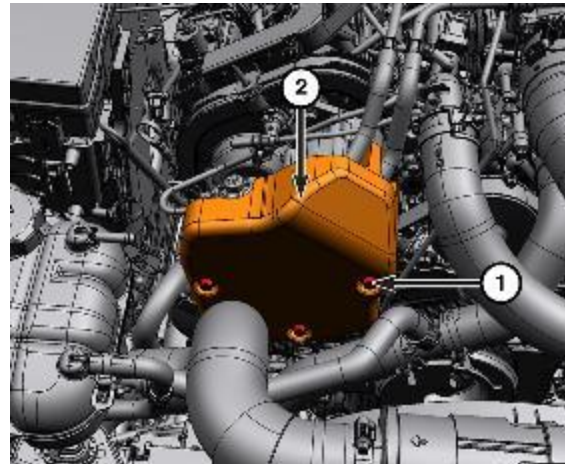
**SAFETY RECALL**  
NORTH AMERICA  
**High Pressure Fuel Pump**



Reference: Z46 / NHTSA 22V-406

FCA US LLC

7. Remove the screws (1) that secure the cover (2) for the high-pressure fuel pump (Figure 24).



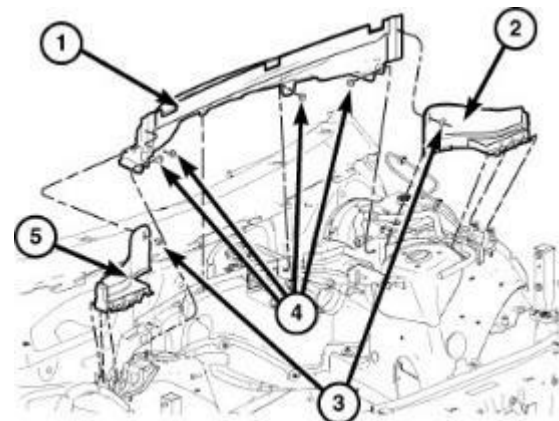
**Figure 24 – Cover Screws**

8. Remove the engine cover (1) (Figure 25).



**Figure 25 – Engine Cover**

9. Remove the cowl extension (1) and the side extensions (2, 5) (Refer to 23 - Body/Exterior/SILENCER, Cowl Extension/Removal) (Figure 26).



**Figure 26 – Engine Cover**

Strictly respect STELLANTIS Group safety, cleanliness, and environmental instructions for any vehicle service.  
Document exclusively reserved for dealer information. Internal distribution to be ensured by dealer.  
Reproduction forbidden without the written agreement of STELLANTIS Group. (C) 2023 STELLANTIS Group. All Rights Reserved

(dit)

# SAFETY RECALL

NORTH AMERICA

## High Pressure Fuel Pump



Reference: Z46 / NHTSA 22V-406

FCA US LLC

10. Remove the bolts (2) and pull up on the engine wire harness assembly (1) to release retainers from the intake manifold (Figure 27).

**WARNING: No sparks, open flames or smoking. Risk of poisoning from inhaling and swallowing fuel. Risk of injury to eyes and skin from contact with fuel. Pour fuels only into suitable and appropriately marked containers. Wear protective clothing.**

**NOTE: Use a backing wrench on the fuel injector when unscrewing the union nut.**

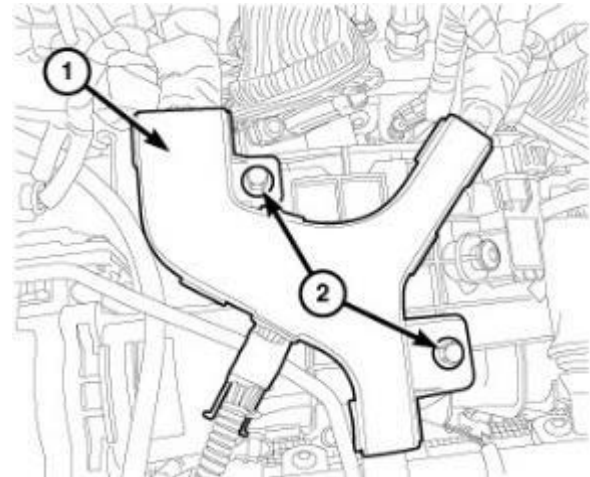


Figure 27 – Engine Wiring Harness

11. Remove the left Charge Air Cooler (CAC) tube.
12. Remove the fuel injector silencers (1) (Figure 28).

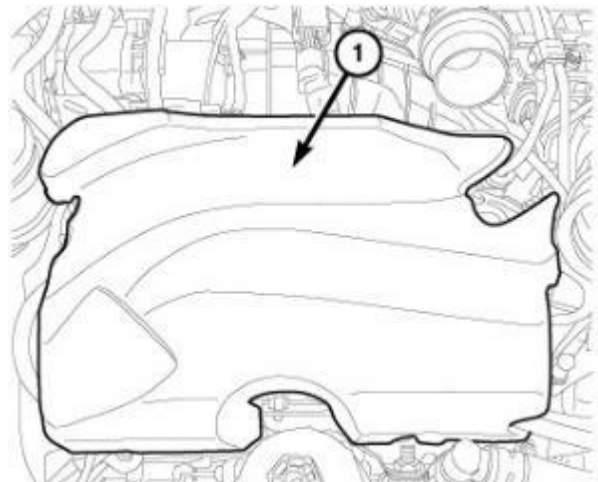


Figure 28 – Silencer Pad

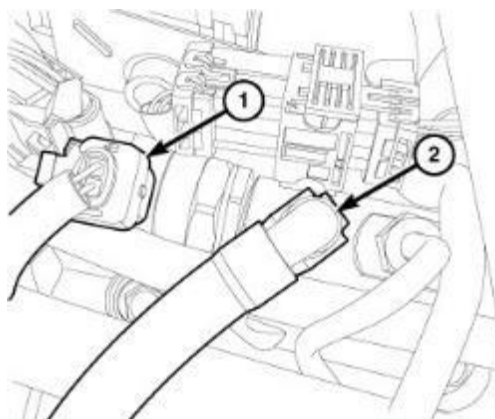
**SAFETY RECALL**  
NORTH AMERICA  
**High Pressure Fuel Pump**



Reference: Z46 / NHTSA 22V-406

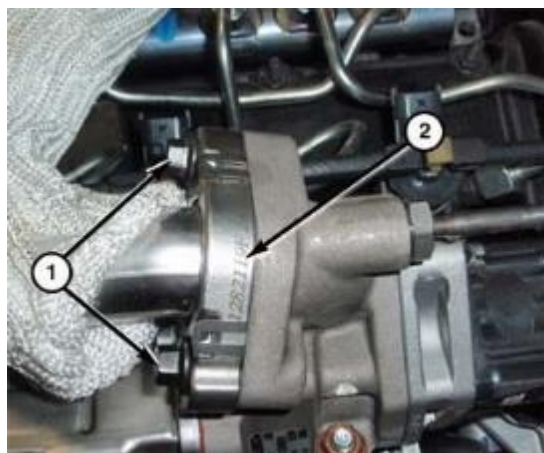
FCA US LLC

- 13. Disconnect the fuel pressure solenoid wire harness connector (1) (Figure 29).
- 14. Disconnect the fuel rail return line (2) and position aside (Figure 29).



**Figure 29 – Harness Connector and Return Line**

- 15. Remove the upper EGR tube bolts (1) (Figure 30) and (2) (Figure 31).
- 16. Remove and discard both gaskets.



**Figure 30 – Upper EGR Tube Bolts**



**Figure 31 – Upper EGR Tube Bolts at Intake**

# SAFETY RECALL

NORTH AMERICA

## High Pressure Fuel Pump



Reference: Z46 / NHTSA 22V-406

FCA US LLC

17. Unscrew the union nuts (1 and 3) and remove and discard the left and right-side fuel tubes (2) (Figure 32).
18. Install protective caps onto the fuel injectors and fuel rail.

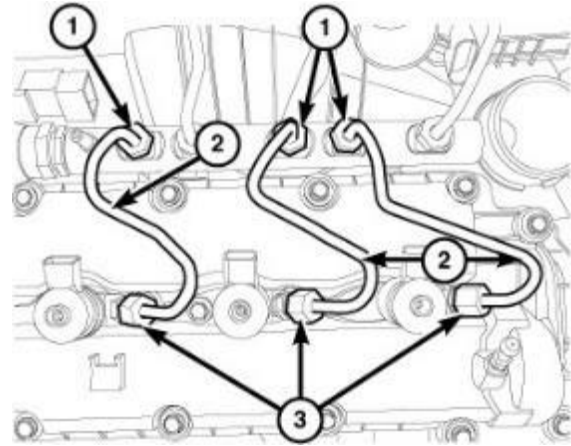


Figure 32 – Fuel Tubes (Left Side Shown, Right Side Similar)

19. Remove the nut (1) securing the right high-pressure fuel tube (3) to cylinder head cover (Figure 33).
20. Remove the union nuts (2, 4) and the right high-pressure fuel tube (3), discard the fuel tube (Figure 33).
21. Remove the bolt (6) securing the high-pressure crossover fuel tube (7) to top of intake manifold (Figure 33).
22. Loosen the union nuts (5, 8) and remove the high-pressure crossover fuel tube (7), discard the fuel tube (Figure 33).
23. Remove the bolt (9) securing the left side fuel tube (11) to EGR air flow control valve (Figure 33).
24. Loosen the union nuts (10, 12) and remove the left high pressure fuel tube (11), discard the fuel tube (Figure 33).

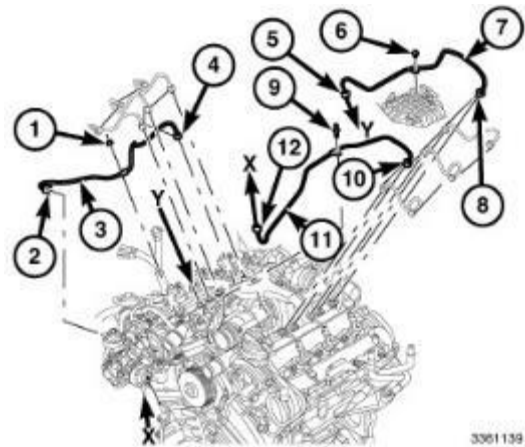


Figure 33 – Right Side Fuel Tubes

**NOTE: The fuel injection pump can be replaced without having to perform the entire base engine valve timing procedure. This procedure gives instruction on how to remove and install the new fuel injection pump without performing the base engine timing. Do not rotate the pump shaft after removing from the vehicle. The alignment of the pump shaft must be measured and recorded using a commercially available degree wheel after the pump is removed and before transferring the pump gear over to the new pump. This is done to align the pump to the same position during installation. If the base engine valve timing must be performed as part of the repair (Refer to 09 - Engine/Valve Timing/Standard Procedure).**

**NOTE: When key is cycled to the off position, fuel system pressure automatically bleeds down.**

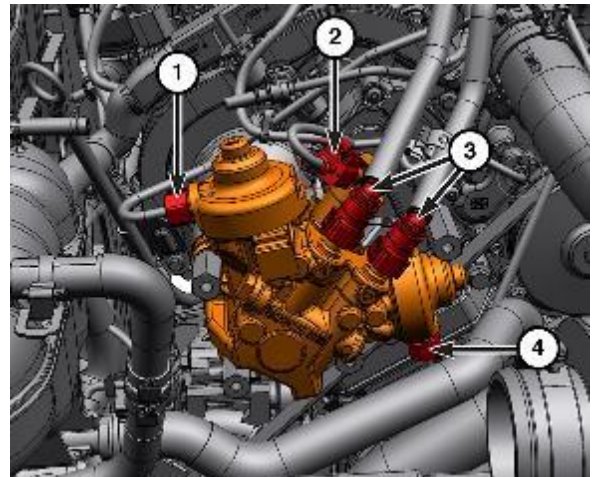
**SAFETY RECALL**  
NORTH AMERICA  
**High Pressure Fuel Pump**



Reference: Z46 / NHTSA 22V-406

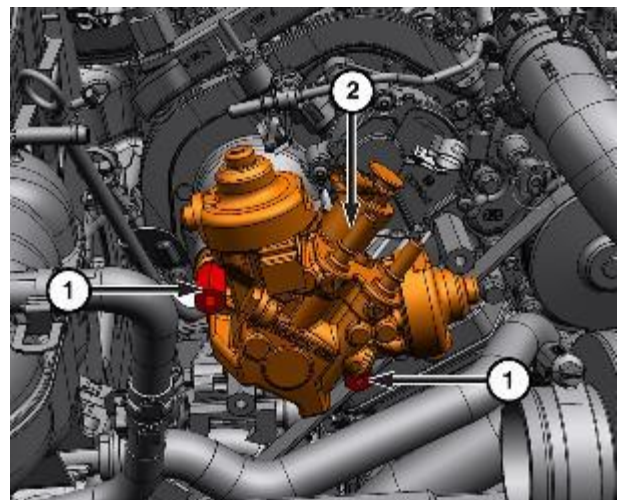
FCA US LLC

- 25. Disconnect the low-pressure fuel supply lines (3) (Figure 34).
- 26. Disconnect the fuel quantity solenoid wire harness connector (2) (Figure 34).



**Figure 34 – HPFP Connections**

- 27. Remove the upper bolts (1) from the high-pressure pump (2) (Figure 35).
- 28. Using Tool, High Pressure Pump Installation VM.10345 Install the studs in the upper locations.



**Figure 35 – Upper Bolts**





# SAFETY RECALL

NORTH AMERICA

## High Pressure Fuel Pump

Reference: Z46 / NHTSA 22V-406



FCA US LLC

**NOTE:** The use of Puller 1023 or a commercially available gear puller is required to remove the fuel injection pump gear (2) (Figure 38).

**CAUTION:** Do Not Force the high-pressure pump into the right timing cover or attempt to seat it by drawing it in with the bolts. The pump gear must be properly aligned with the drive gear on the camshaft before the high-pressure pump will seat on the cylinder head mounting surface. Failure to properly align drive gears will damage the high-pressure pump or camshaft drive gear.

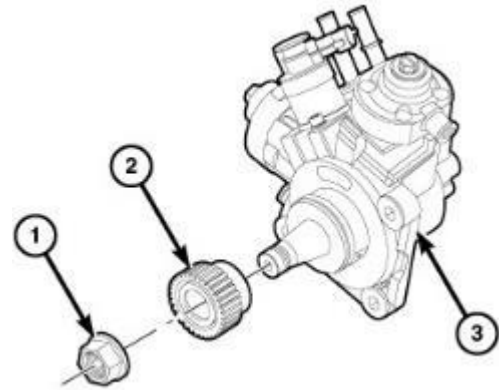


Figure 38 – Drive Gear on the HPFP

31. Using a commercially available spanner wrench such as Blue Point APS351B, Snap-on APS351C or equivalent (2) to hold fuel injection pump gear. Remove the fuel injection pump gear nut (1) (Figure 39).



Figure 39 – HPFP Gear Removal

# SAFETY RECALL

NORTH AMERICA

## High Pressure Fuel Pump



Reference: Z46 / NHTSA 22V-406

FCA US LLC

32. Install a **NEW** O-ring seal (1) to the **NEW** fuel injection pump.
33. Install the gear (2) and nut (1) onto the fuel injection pump (3) and tighten the nut (1) finger tight (Figure 38).
34. Using a commercially available spanner wrench (2) such as Blue Point APS351B or equivalent and tighten the nut (1) to 50 N·m (37 Ft. Lbs.) (Figure 39).
35. Install the degree wheel and rotate the pump shaft so that the hole aligns with the reference mark on the degree wheel referenced during the removal (Figure 37).

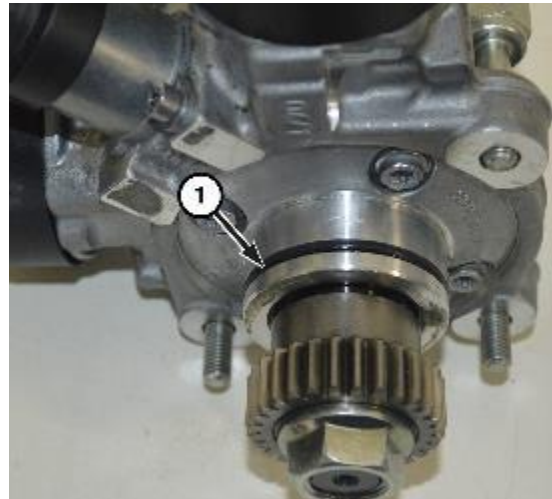


Figure 40 – HPFP O-ring

36. Disconnect the injector electrical connector (1) (Figure 41).
37. Lift up on the locking retaining tab on the fuel return lines (2) to unlock the lock. Remove the fuel return hose (3) by wiggling hose free at the fuel injector (4) (Figure 41).

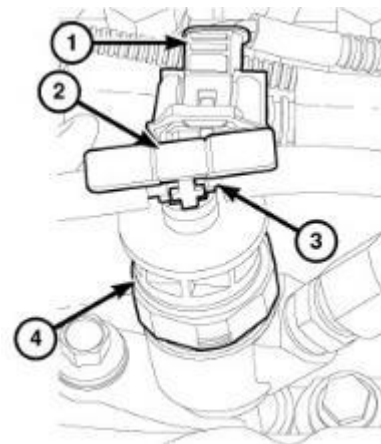


Figure 41 – Fuel Injector Return Line and Locking Tab

# SAFETY RECALL

NORTH AMERICA

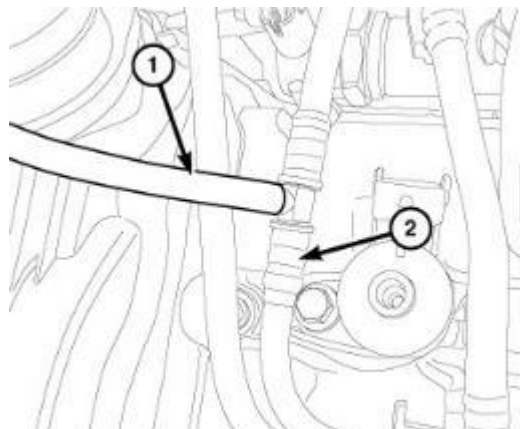
## High Pressure Fuel Pump

Reference: Z46 / NHTSA 22V-406



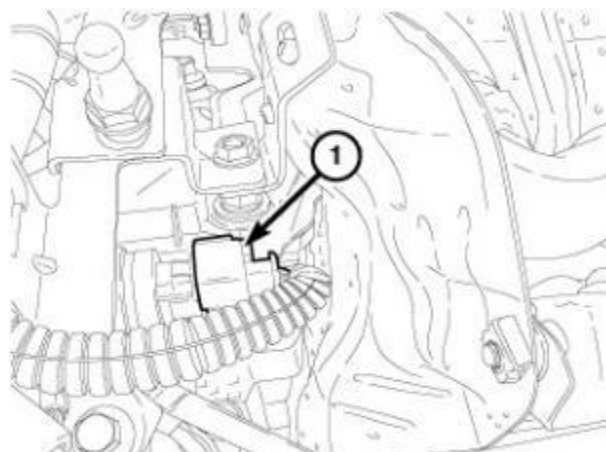
FCA US LLC

38. Remove the fuel injector return line (1) from the main low pressure return line (2) (Figure 42).



**Figure 42 – Fuel Injector Return Line to Low Pressure Return Line**

39. Disconnect the right fuel rail pressure sensor wire harness connector (1) (Figure 43).



**Figure 43 – Fuel Rail Pressure Sensor Connector**

# SAFETY RECALL

NORTH AMERICA

## High Pressure Fuel Pump



Reference: Z46 / NHTSA 22V-406

FCA US LLC

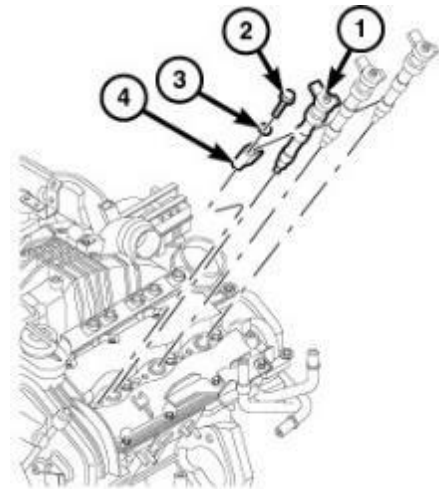
40. Using the Remover-Installer, Fuel Rail Bolt 2025400090 (1) remove the bolts from both fuel rails and remove and discard the rails from the engine (Figure 44).
41. Clean the area around the fuel injector to be removed, so no debris falls into the injector bore.

**NOTE: Use care not to drop or lose the old washer.**



**Figure 44 – Fuel Rail Bolts**

42. Remove the fuel injector hold-down bolt (2), washer (3), and retaining claw (4) (Figure 45).
43. Using your hand, pull fuel injector (1) straight up from cylinder head for removal. Discard lower sealing washer and injector (Figure 45).



**Figure 45 – Fuel Injector Removal**

# SAFETY RECALL

NORTH AMERICA

## High Pressure Fuel Pump



Reference: Z46 / NHTSA 22V-406

FCA US LLC

44. If the fuel injector can't be removed by hand, install the Remover, Fuel Injector VM.10358A (1) to remove the fuel injector (2) (Figure 46).

**NOTE: Check and make sure that the copper sealing washer did not remain in the cylinder head.**

**NOTE: Before cleaning the injector bore, seal the injector holes in the injector bore with the appropriate cap to prevent debris from falling into the cylinder.**

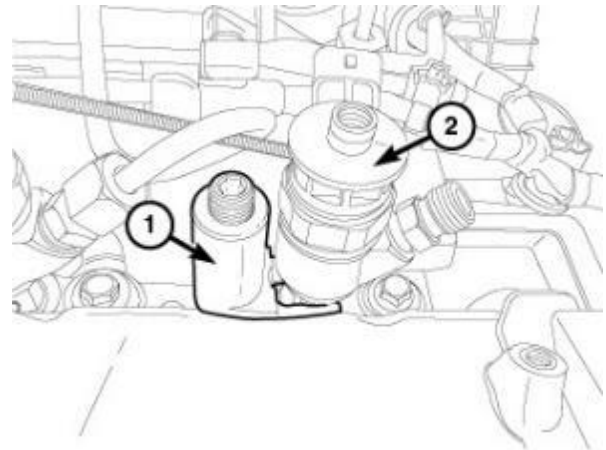


Figure 46 – Fuel Injector Removal Tool

45. Using a lint-free rag, wipe the cylinder head around the fuel injector.
46. Wipe out injector bore with a lint-free cloth.

**CAUTION: Make sure the injector bore bottom is clean of debris otherwise a leak could occur.**

47. Clean the bottom of the fuel injector bore with Brush, Injector Bore 9717 and **make sure the old copper sealing washer (2) is not stuck in the bore** (Figure 47).
48. Blow out the recess with shop air and clean again with a lint-free cloth and cover over.
49. Perform these steps for each injector recess.

**NOTE: Do Not apply anti-seize lubricant to the injector nozzle, only apply anti-seize lubricant to the injector body.**

50. Lubricate the **NEW** fuel injector body with Nickel Anti-Seize lubricant.

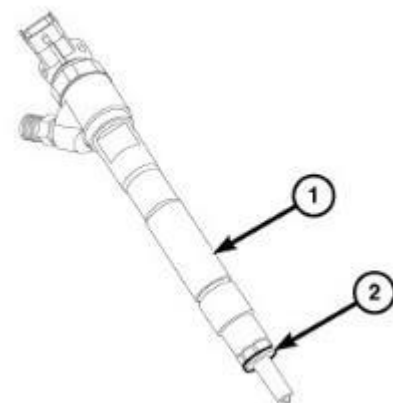


Figure 47 – Fuel Injector

**NOTE: Always replace the seals in the cylinder head cover and replace the copper sealing washer on the bottom of injector.**

**NOTE: Any time a new injector is installed, or if an existing injector is installed in any location other than its original location, the injector quantity adjustment procedure must be performed (Refer to 14 - Fuel System/Fuel Injection - Standard Procedure).**

51. Remove protective cap from the appropriate injector bore.

**NOTE: Make sure the old copper sealing washer is not stuck in bore.**

# SAFETY RECALL

NORTH AMERICA

## High Pressure Fuel Pump



Reference: Z46 / NHTSA 22V-406

FCA US LLC

52. Install a **NEW** fuel injector seal (1) in the cylinder head cover (2) (Figure 48).

**NOTE: Do Not apply any lubricant to the fuel injector nozzle. Care must be taken not to restrict the discharge orifices in the nozzle.**

53. Install a **NEW** sealing washer (2) onto the fuel injector (1) (Figure 47).

54. Lubricate the injector body with Nickel Anti-Seize Lubricant.

**NOTE: Make a note of the seven-digit alphanumeric codes and the physical location of each injector. You will need to enter them into the scan tool during the Injector Quantity Adjustment procedure.**

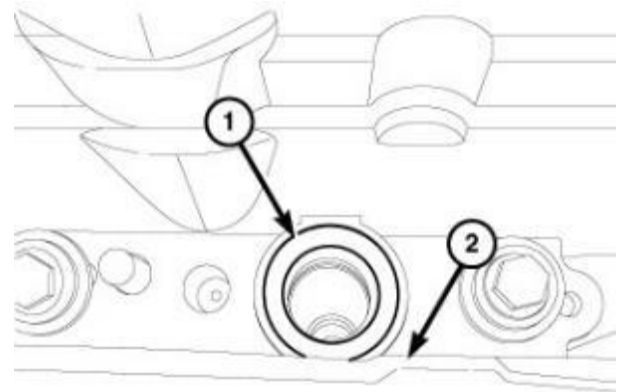


Figure 48 – Fuel Injector Seal

55. Install the fuel injector (1), tensioning claws (4), washer (3) and bolt (2). Tighten the bolt (2) to 33 N·m (24 ft. lbs.) (Figure 45).

**NOTE: Fuel tubes are a one-time only use and must be replaced anytime they have been removed.**

56. Install the fuel rails. Using the Remover-Installer, Fuel Rail Bolt 2025400090 (1), tighten bolts to 25 N·m (18 ft. lbs.) (Figure 44).

57. Connect the right fuel rail pressure sensor wire harness connector (1) (Figure 41).

**NOTE: The one-way check valves on the fuel injector lines are NOT serviceable and should not be taken apart. If the one-way check valve is bad then a NEW fuel injector return line will need to be installed.**

**NOTE: Before installing the fuel injector return line assembly, verify the arrow on the one-way valve point towards the fuel tank**

**NOTE: Do not use any type of lubrication when installing the fuel injector return line.**

**NOTE: BE SURE THE FUEL INJECTOR RETURN LINE LOCK TAB (2) IS IN THE UNLOCKED POSITION.**

58. Inspect the fuel injector return line for cracks and inspect the O-ring seals for damage. Replace the fuel injector return line if a problem exists.

59. Install the fuel injector return line (1) to the main low pressure return line (2) (Figure 40).

60. Install the fuel injector return line (3) and **BE SURE IT IS FULLY SEATED**, then push down on the lock tab (2) to lock in place. (Figure 39).

61. Connect the fuel injector harness connector (1) (Figure 39).

# SAFETY RECALL

NORTH AMERICA

## High Pressure Fuel Pump



Reference: Z46 / NHTSA 22V-406

FCA US LLC

**CAUTION: Do Not Force the high-pressure pump into the right timing cover or attempt to seat it by drawing it in with the bolts. The pump gear must be properly aligned with the drive gear on the camshaft before the high-pressure pump will seat on the cylinder head mounting surface. Failure to properly align drive gears will damage the high-pressure pump or camshaft drive gear.**

62. Install the Tool, High Pressure Pump Installation VM.10345 into the studs installed in the upper timing cover.
63. Install the lower fuel injection pump (2) and hand tighten the bolt (1) (Figure 34).
64. Remove the Tool, High Pressure Pump Installation VM.10345 from the upper bolts location and install the bolts.
65. Tighten the bolts (1) that secure the fuel injection pump to 25 N·m (18 ft. lbs.) (Figure 33 & 34).
66. Connect the fuel injection pump electrical connector (2) (Figure 34).
67. **Do not** connect the low-pressure fuel supply and return lines (3) at this time (Figure 34).

**NOTE: Fuel tubes are a one-time only use and must be replaced anytime they have been removed.**

68. Install the **NEW** left high pressure fuel tube (11) and tighten the union nut (10, 12) finger tight (Figure 33):
  - Tighten the union nut (10) to 5 N·m (44 in. lbs.) plus an additional 75 degrees turn.
  - Tighten the union nut (12) to 11 N·m (8 ft. lbs.) plus an additional 75 degrees turn.
69. Install the bolt (9) securing the left side high pressure fuel tube (11) to EGR air flow control valve and tighten to 11 N·m (8 ft. lbs.) (Figure 33).
70. Install the **NEW** high pressure crossover fuel tube (7) and tighten the union nuts (5, 8) finger tight (Figure 33):
  - Tighten the union nut (5, 8) to 5 N·m (44 in. lbs.) plus an additional 75 degrees turn.
71. Install the bolt (6) securing the high-pressure crossover fuel tube (7) to intake manifold and tighten to 11 N·m (8 ft. lbs.) (Figure 33).
72. Install the **NEW** right high-pressure fuel tube (3) and tighten union nut (2, 4) finger tight (Figure 33):
  - Tighten the union nut (4) to 5 N·m (44 in. lbs.) plus an additional 75 degrees turn.
  - Tighten the union nut (2) to 11 N·m (8 ft. lbs.) plus an additional 75 degrees turn.
73. Install the nut (1) securing the right-side high-pressure fuel tube (3) to right side cylinder head cover and tighten to 11 N·m (8 ft. lbs.) (Figure 33).
74. Remove the protective caps from the fuel injectors and fuel rail.

**NOTE: Use a backing wrench on the fuel injector when tightening the union nut.**

75. Install the **NEW** right side fuel tubes (2) and tighten the union nuts (1, 3) finger tight (Figure 33):
  - Tighten the union nut (1) to 5 N·m (44 in. lbs.) plus an additional 75 degrees turn.
  - Tighten the union nut (3) to 11 N·m (8 ft. lbs.) plus an additional 75 degrees turn.



76. Remove the protective caps from the fuel injectors and fuel rail.
77. Install **NEW** left side fuel tubes (2) and tighten the union nuts (1 and 3) finger tight (Figure 33):
  - Tighten the union nut (1) to 5 N·m (44 in. lbs.) plus an additional 75 degrees turn.
  - Tighten the union nut (3) to 11 N·m (8 ft. lbs.) plus an additional 75 degrees turn.
78. Clean all gasket sealing areas (Figures 30 & 31).
79. Install a **NEW** O-ring gasket (1) onto the intake manifold (2) (Figure 31).
80. Install a **NEW** gasket to the EGR pipe (Figure 30).
81. Install the EGR tube (1) and tighten the bolts (2) to 11 N·m (8 ft. lbs.) (Figure 31).
82. Install the EGR tube bolts (1) and tighten to 25 N·m (18 ft. lbs.) (Figure 30).
83. Install the cowl extension (1) and the side extensions (2, 5) (Refer to 23 - Body/Exterior/SILENCER - Installation) (Figure 25).

**NOTE: If the fuel system has been contaminated with Metal or Other Foreign Objects, the following procedure must be followed.**

**NOTE: With the electric fuel pump not operating, the fuel tank must be removed and drained through the fuel pump module opening of the fuel tank.**

84. Raise and support the vehicle (Refer to 04 - Vehicle Quick Reference/Hoisting - Standard Procedure).
85. Remove fuel pump module (Refer to 14 - Fuel System/Fuel Delivery/MODULE, Fuel Pump - Removal).
86. After fuel pump module has been removed, drain fuel into an approved diesel fuel draining station.

**CAUTION: Dispose of petroleum-based products in a manner consistent with all applicable Local, State, Federal, and Provincial regulations.**

87. Ensure the swirl pot indentation below the in-tank electric fuel pump inlet is completely drained of any contaminated fuel and thoroughly clean the fuel tank.
88. Install the **NEW** Fuel Pump and **New** Transfer Pump.
89. Install the fuel tank and fill with clean diesel fuel. **Do Not** connect the low pressure return line at this time.
90. Remove the transmission skid plate (Refer to 13 - Frame and Bumpers/Under Body Protection/PLATE, Skid - Removal).

# SAFETY RECALL

NORTH AMERICA

## High Pressure Fuel Pump

Reference: Z46 / NHTSA 22V-406



FCA US LLC

- 91. Loosen the drain plug (2) and drain the diesel fuel into a suitable container (Figure 49).
- 92. Securely tighten the drain plug (2).

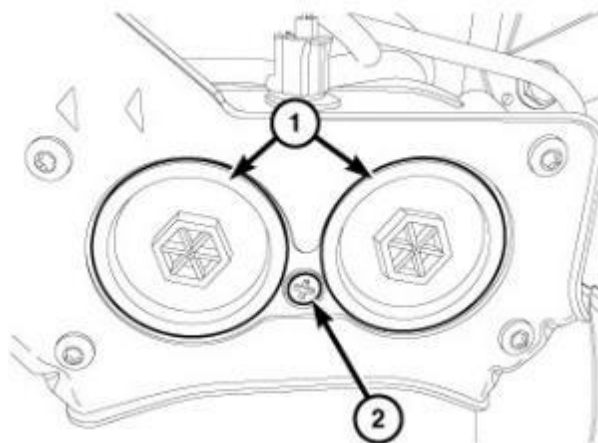


Figure 49 – Drain Plug

- 93. Remove the nuts (2) and the fuel filter shield (1) (Figure 50).

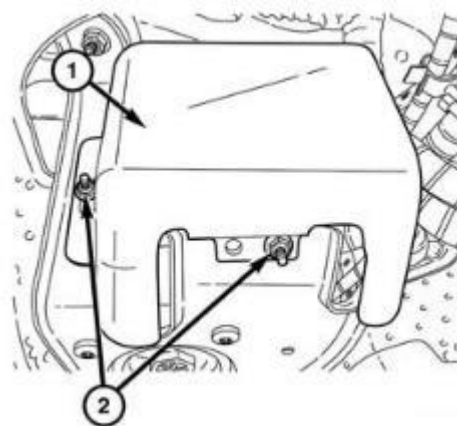


Figure 50 – Fuel Filter Shield

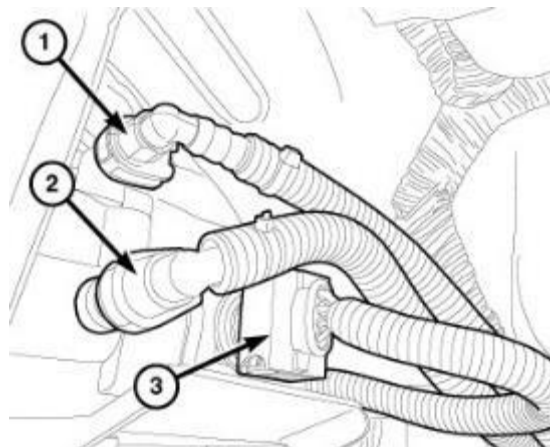
**SAFETY RECALL**  
NORTH AMERICA  
**High Pressure Fuel Pump**



Reference: Z46 / NHTSA 22V-406

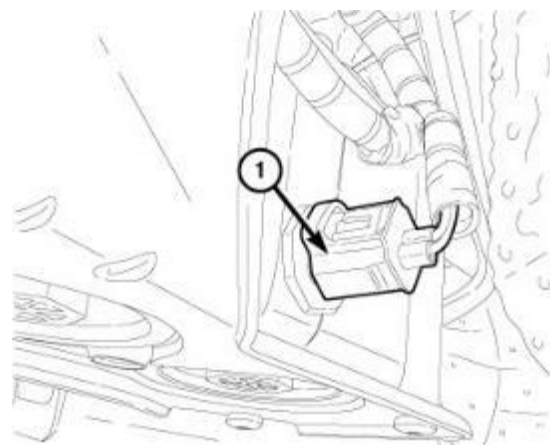
FCA US LLC

- 94. Disconnect the fuel filter/water separator outlet fuel line (1) (Figure 51).
- 95. Disconnect the fuel filter/water separator inlet fuel line (2) (Figure 51).
- 96. Disconnect the combination fuel heater/temperature sensor wire harness connector (3) (Figure 51).



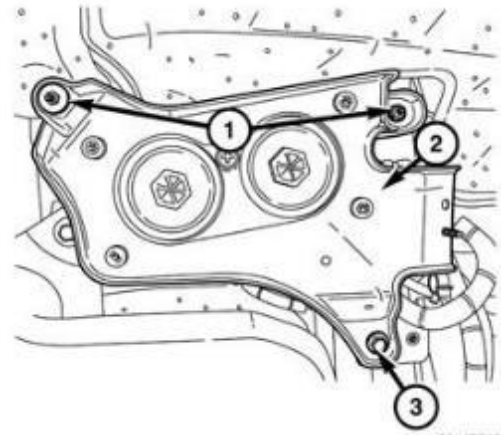
**Figure 51 – Inlet and Outlet Lines**

- 97. Disconnect the Water In Fuel (WIF) sensor wire harness connector (1) (Figure 52).



**Figure 52 – WIF Sensor Connector**

98. Remove the nuts (1), bolt (3), and the fuel filter/water separator assembly (2) (Figure 53).



**Figure 53 – Fuel Filter/Water Separator**

99. Clean the outside of the housing. Remove and discard each fuel filter cover and the fuel filter element from the bottom of the fuel filter/water separator (Figure 54).



**Figure 54 – Remove Old Filter Covers and Elements**

**SAFETY RECALL**  
NORTH AMERICA  
**High Pressure Fuel Pump**



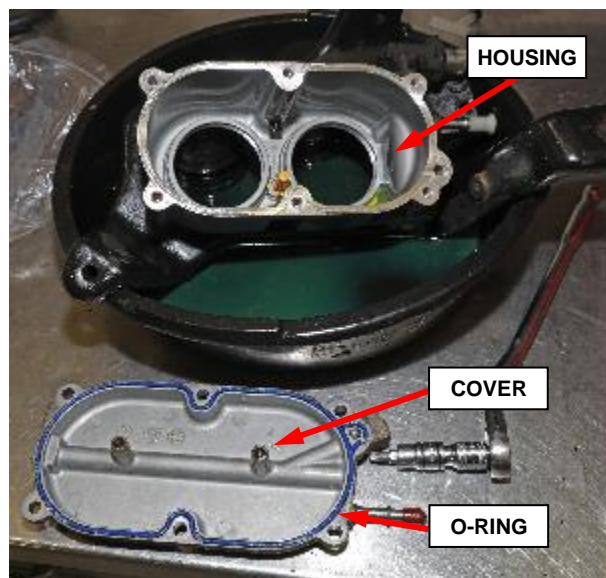
Reference: Z46 / NHTSA 22V-406

FCA US LLC

100. From the top of the fuel filter/water separator, remove the cover (Figures 55 & 56).



**Figure 55 – Remove Fuel Filter/Water Separator Cover**



**Figure 56 – Fuel Filter/Water Separator Cover Removed**

# SAFETY RECALL

NORTH AMERICA  
High Pressure Fuel Pump

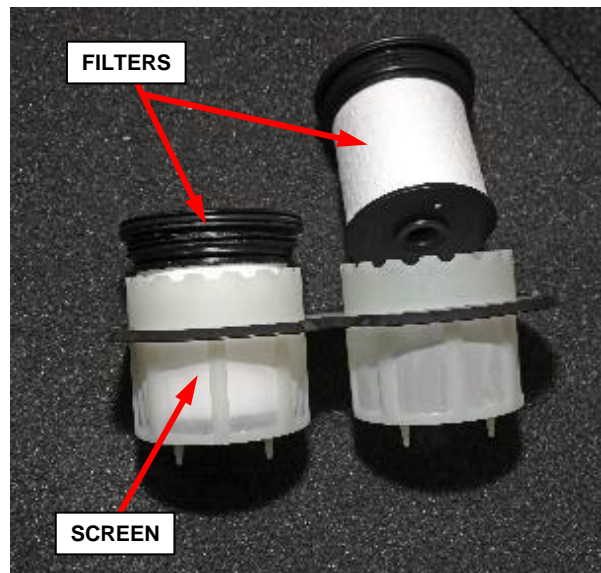


Reference: Z46 / NHTSA 22V-406

FCA US LLC

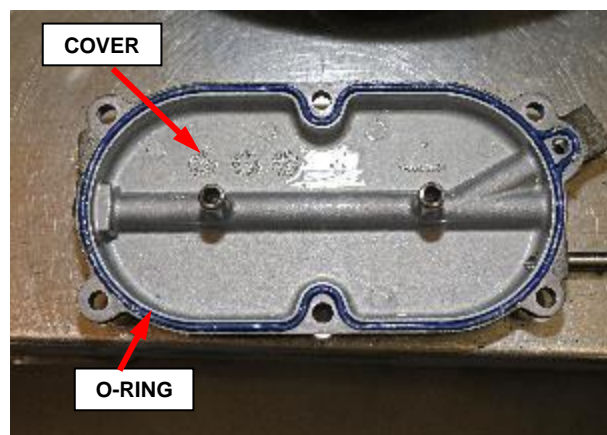
**NOTE:** The **NEW** Fuel Filter Kit contains two filter elements, a cover O-ring (not shown) and a filter screen (Figure 57).

101. Thoroughly clean the inside of the housing and cover.



**Figure 57 – New Fuel Filter Kit**

102. Remove and discard the old cover O-ring. Lubricate the **NEW** seal with clean diesel and install it into the channel in the cover (Figure 58).



**Figure 58 – Cover O-ring**

**SAFETY RECALL**  
NORTH AMERICA  
**High Pressure Fuel Pump**



Reference: Z46 / NHTSA 22V-406

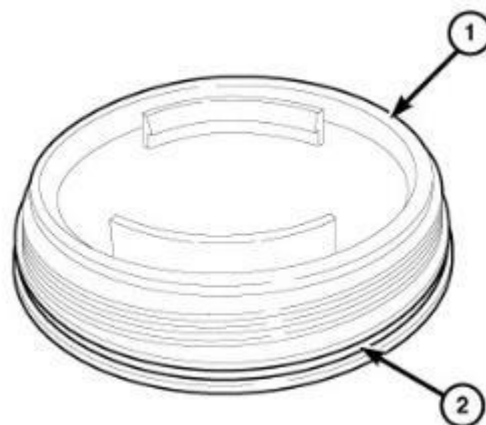
FCA US LLC

- 103. Install the **NEW** screen into the housing as shown in Figure 58. Check that the screen is fully and evenly seating into the housing (Figure 59).
- 104. Install the cover. Apply fresh LocTite 270 or equivalent to the cover screws and tighten to 24 N·m (18 ft. lbs.).



**Figure 59 – Screen Installed**

- 105. Lubricate the **NEW** O-ring seal (2) on filter covers (1) with clean diesel (Figure 60).



**Figure 60 – Filter Cover O-ring**

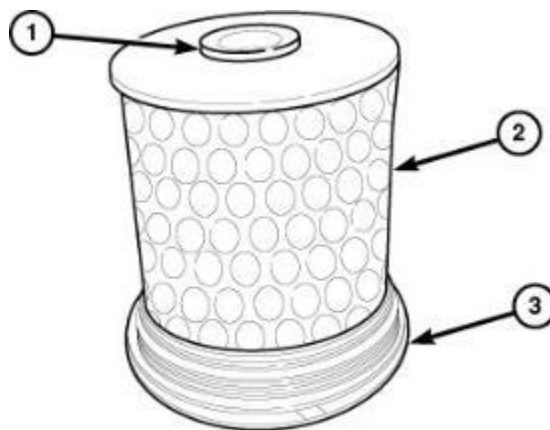
**SAFETY RECALL**  
NORTH AMERICA  
**High Pressure Fuel Pump**



Reference: Z46 / NHTSA 22V-406

FCA US LLC

- 106. Position and push down on **NEW** fuel filters (2) to install filter onto the cover (3) (Figure 61).
- 107. Lubricate the rubber seal (1) with clean diesel fluid (Figure 61).



**Figure 61 – Filter Seal**

- 108. Install each fuel filter. Tighten each cover (1) to 20 N·m (15 ft. lbs.) (Figure 62).



**Figure 62 – Filters Installed**



109. Install the fuel filter/water separator assembly (2) to the vehicle. Tighten the two nuts (1), and one bolt (3) to 20 N·m (15 ft. lbs.) (Figure 53).
110. Connect the Water In Fuel (WIF) sensor wire harness connector (1) (Figure 52).
111. Connect the combination fuel heater/temperature sensor wire harness connector (3) (Figure 51).
112. Connect the fuel filter/water separator inlet fuel line (2) (Figure 51).
113. Connect the fuel filter/water separator outlet fuel line (1) (Figure 51).
114. Install the fuel filter shield (1). Tighten the nuts (2) 14 N·m (10 ft. lbs.) (Figure 50).
115. Lower the vehicle.
116. Connect the negative battery cable to the battery.

**NOTE: If equipped with an Intelligent Battery Sensor (IBS), connect the IBS connector after connecting the negative battery cable.**

117. Install the battery cover (1) (Figure 21).
118. Place a suitable container under the low-pressure fuel feed line previously left disconnected at the HPFP.
119. Using a diagnostic scan tool, activate the fuel pump to flush the low-pressure fuel lines from the tank to the HPFP.
120. Connect the low-pressure fuel feed at the HPFP.
121. Place a suitable container under the low-pressure fuel return line previously left disconnected at the fuel tank.
122. Using a diagnostic scan tool, activate the fuel pump to flush the low-pressure fuel return lines from the HPFP to the fuel tank.
123. Connect the low pressure fuel return line at the fuel tank.

#### **INJECTOR CLASSIFICATION PROCEDURE**

**NOTE: The engine must not be running for this procedure.**

124. Turn the ignition switch “**ON**”.
125. Using a scantool, select the “**PCM View**”, then “**MISCELLANEOUS FUNCTIONS**”.
126. Select the “**Injector Quantity Adjustment**”, then “**NEXT**”.
127. Select the injector(s) that has been replaced, access the keyboard function, and type the seven-digit alphanumeric code next to the cylinder number that corresponds to the physical location where the injector has been installed.
128. Click “**NEXT**”. The scan tool will prompt to turn the ignition switch off for 12 seconds.

**SAFETY RECALL**  
NORTH AMERICA  
**High Pressure Fuel Pump**



Reference: Z46 / NHTSA 22V-406

FCA US LLC

- 
129. Repeat steps **127** and **128** for the other injectors that are new.
  130. Once the seven-digit alphanumeric codes for all injectors have been entered into the PCM, cycle ignition to complete the procedure.

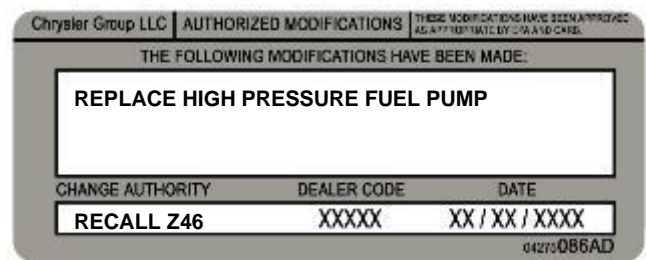
**NOTE: When ever a fuel injector is replaced run oxygen sensor value reset function.**

131. Using the scan tool, perform "**Oxygen Sensor Value Reset**" function found under "**ENGINE MISCELLANEOUS FUNCTIONS**".
132. Connect the vacuum line (Figure 23).
133. Connect the degas hose (Figure 22).
134. Start engine, allow to warm, turn engine off. Check and verify there are no leaks (Refer to 14 - Fuel System/Fuel Delivery, Diesel/Tube(s), Fuel/Diagnosis and Testing).
135. Install the fuel injection pump cover (2) and tighten the screws (1) securely (Figure 24).
136. Install the engine silencer pads (Figure 27) and engine cover (Figure 25).

**NOTE:** For all platforms above and both contaminated and non-contaminated systems, complete step C. Install the Authorized Modifications Label.

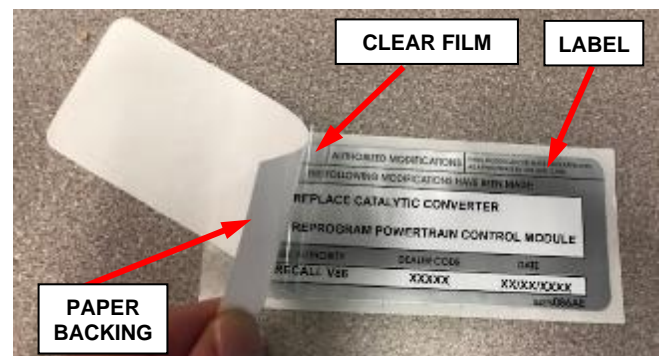
**C. Install the Authorized Modifications Label:**

1. Type or print (with a ballpoint pen) the necessary information shown in (Figure 63) onto the authorized modifications Label.



**Figure 63 – Authorized Modifications Label**

2. Remove the paper backing from the clear film on the front of the authorized modifications label then carefully apply the clear film over the front of the authorized modifications label (Figure 64).



**Figure 64 – Apply Clear Film**

**SAFETY RECALL**  
NORTH AMERICA  
**High Pressure Fuel Pump**



Reference: Z46 / NHTSA 22V-406

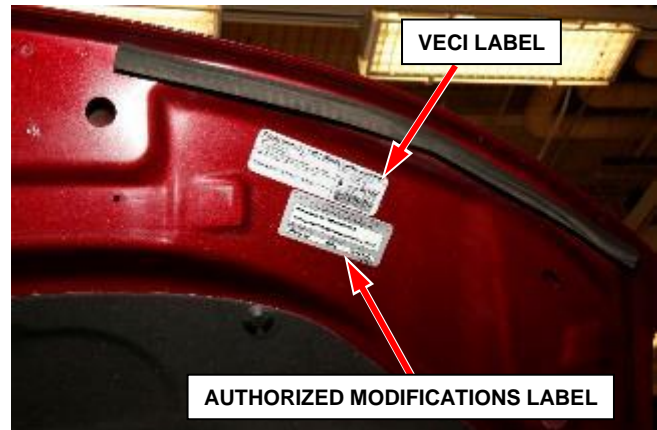
FCA US LLC

**NOTE: The Authorized Modifications Label should be located near the Vehicle Emission Control Information (VECI) label (Figure 65).**

3. Locate the VECI label on the underside of the engine compartment hood (Figure 65).

**NOTE: For vehicles missing a VECI label, locate a flat protected area on the underside of the hood to apply the authorized modifications label.**

4. Clean the surface near the VECI label with isopropyl alcohol or equivalent and a soft cloth.



**Figure 65 – Apply Authorized Modifications Label Near VECI Label  
(Specific Vehicle May Look Different)**

5. Remove the authorized modifications label from its paper backing.
6. Apply the authorized modifications label next to the VECI label (Figure 65).
7. Firmly press and smooth the authorized modifications label to ensure good adhesion.
8. Close the engine compartment hood.
9. Complete the Proof of Correction Form for California Residents, **Section D**.

#### **D. Complete Proof of Correction Form for California Residents:**

This recall is subject to the **State of California Registration Renewal/Emissions Recall Enforcement Program**. Complete a Vehicle Emission Recall Proof of Correction Form (**Form No. 81-016-1053**) and **supply it to vehicle owners residing in the state of California** for proof that this recall has been performed when they renew the vehicle registration.

Process Steps to obtain the California Proof of Correction form:

- a. Access the “**DealerCONNECT**” website.
- b. Select the “**Service**” tab.
- c. Under the “**Publications**” heading, select the “**ePublishing**” link.
- d. Sign in using your **Dealer Code** and **Password**.
- e. Select the “**Proof of Correction form**”.

#### **E. Owner’s Manual Addendum and Tip Card:**

From Campaign kit CSFP01A1AA, place the Owner’s Manual Addendum in the glovebox with the Owner’s Manual.

Place the Tip Card in a conspicuous location that will be visible to the driver so that they will review it. Suggestions would be the top of the instrument panel, in front of the instrument cluster, etc. Please review the information on the card with the owner when the vehicle is returned to them.

## **F. Fuel Door Label:**

**NOTE: Do not apply the label over an existing label. Apply the label on a flat surface on the inside of the fuel door. For example, on the top of the fuel door hinge (Figure 67).**

From Campaign kit CSFP01A1AA, install the fuel door decal.

1. Open the fuel door.
2. Clean the top surface of the hinge with isopropyl alcohol or equivalent and a soft cloth. Repeat as needed until the soft cloth comes off the surface clean.
3. Remove the fuel door label from its paper backing.
4. Apply the fuel door label (Figure 66) to the top of the fuel door hinge (Figure 67).
5. Firmly press and smooth the fuel door label to ensure good adhesion.
6. Close the fuel door.



**Figure 66 – Fuel Door Label**



**Figure 67 – Fuel Door Hinge Location**

# SAFETY RECALL

NORTH AMERICA

## High Pressure Fuel Pump

Reference: Z46 / NHTSA 22V-406



FCA US LLC

### SERVICE PROCEDURE - DS

For vehicles with a non-contaminated fuel system, use the procedure below.

#### G. Replace HPFP – Non-Contaminated System

**WARNING:** Observe the following precautions when working on fuel systems: No sparks, open flames or smoking. Avoid inhaling and swallowing fuel. Avoid eye and skin contact with fuel. Pour fuels only into suitable and appropriately marked containers. Wear protective clothing. Failure to observe these precautions may result in fire, explosion, property damage, and serious or fatal injury.

**WARNING:** High-pressure fuel lines deliver fuel under extreme pressure from the injection pump to the injectors. This may be as high as 1800 bar (26,106 psi). Use extreme caution when inspecting for high-pressure fuel leaks. Inspect high-pressure fuel leaks with a sheet of cardboard. Wear safety goggles and adequate protective clothing when servicing fuel system. Fuel under this amount of pressure can penetrate skin causing serious or fatal injury.

**NOTE:** The fuel injection pump can be replaced without having to perform the entire base engine valve timing procedure. This procedure gives instruction on how to remove and install the new fuel injection pump without performing the base engine timing. Do not rotate the pump shaft after removing from the vehicle. The alignment of the pump shaft must be measured and recorded using a commercially available degree wheel after the pump is removed and before transferring the pump gear over to the new pump. This is done to align the pump to the same position during installation. If the base engine valve timing must be performed as part of the repair, refer to Service Library 09 - Engine/Valve Timing/Standard Procedure.

**NOTE:** When key is cycled to the off position, fuel system pressure automatically bleeds down.

1. Disconnect and isolate the negative battery cable(s).
2. Remove the retainers (1) that secure the cover (2) for the high-pressure fuel pump (Figure 68).

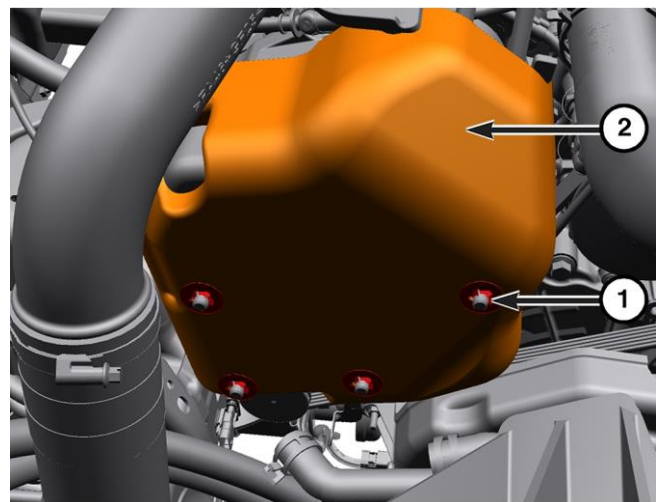


Figure 68 – HPFP Cover

**SAFETY RECALL**  
NORTH AMERICA  
**High Pressure Fuel Pump**



Reference: Z46 / NHTSA 22V-406

FCA US LLC

3. Remove the bolts (1) securing the sound proofing (2) to the fuel injection pump (Figure 69).

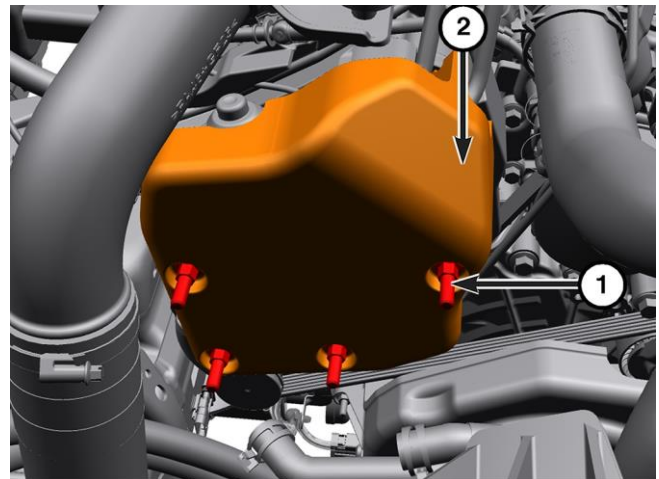


Figure 69 – HPFP Sound Proofing

4. Remove the fuel rail supply tubes (1, 4) (Refer to 14 - Fuel System/Fuel Delivery/TUBE(S), Fuel/Removal and Installation) (Figure 70).
5. Disconnect the low-pressure fuel supply lines (3) (Figure 70).

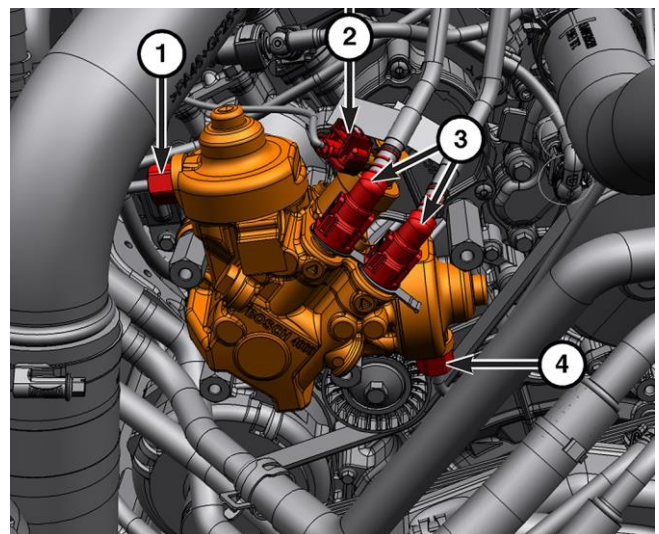


Figure 70 – HPFP Tubes and Lines



# SAFETY RECALL

NORTH AMERICA

## High Pressure Fuel Pump



Reference: Z46 / NHTSA 22V-406

FCA US LLC

6. Disconnect the fuel quantity solenoid wire harness connector (2) (Figure 70).

**NOTE: The fuel injection pump can be replaced without having to perform the entire base engine valve timing procedure. Do not rotate the pump shaft after removing from the vehicle. The alignment of the pump shaft must be measured and recorded using a commercially available degree wheel after the pump is removed and before transferring the pump gear over to the new pump. This is done to align the pump to the same position during installation. If the base engine valve timing must be performed as part of the repair (Refer to 09 - Engine/Valve Timing/Standard Procedure).**

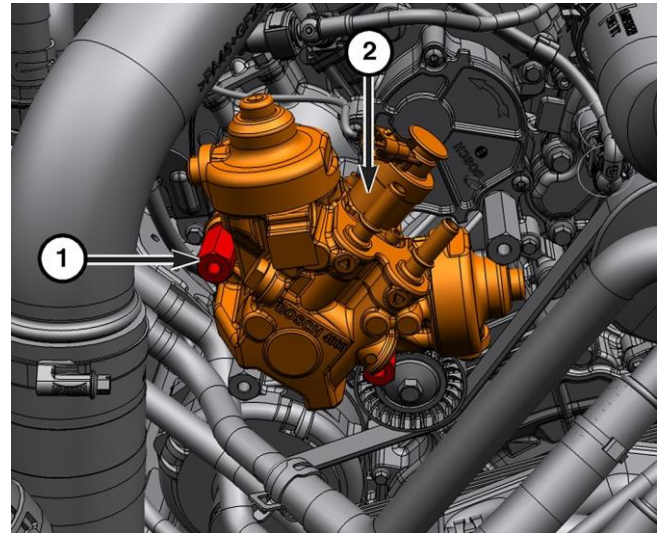


Figure 71 – HPFP Upper Bolts

7. Remove the upper bolts (1) from the high-pressure pump (Figure 71).
8. Using Tool, High Pressure Pump Installation VM.10345 Install the studs in the upper locations.
9. Remove the lower bolt (1) from the HPFP and remove it from the vehicle (Figure 72).

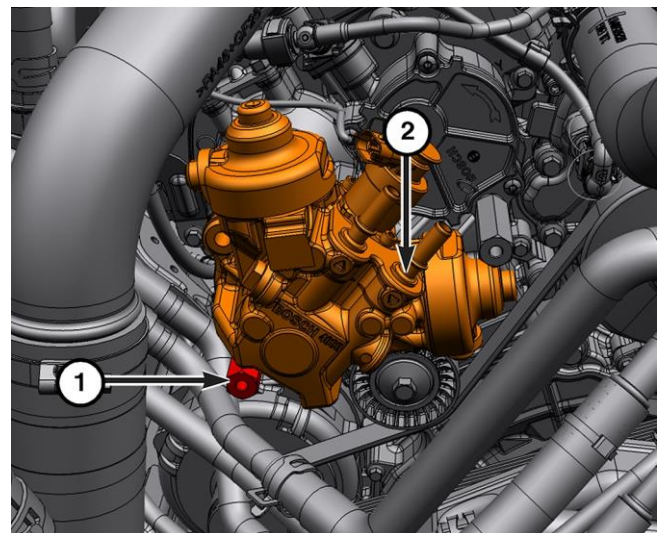


Figure 72 – HPFP Lower Bolts

# SAFETY RECALL

NORTH AMERICA

## High Pressure Fuel Pump

Reference: Z46 / NHTSA 22V-406



FCA US LLC

10. Install the degree wheel onto the pump and record the position of the hole in the gear on the degree wheel (Figure 73).



Figure 73 -- Installing a Printed Paper Degree Wheel from the Internet

**NOTE:** The use of Puller 1023 or a commercially available gear puller is required to remove the fuel injection pump gear (2) (Figure 74).

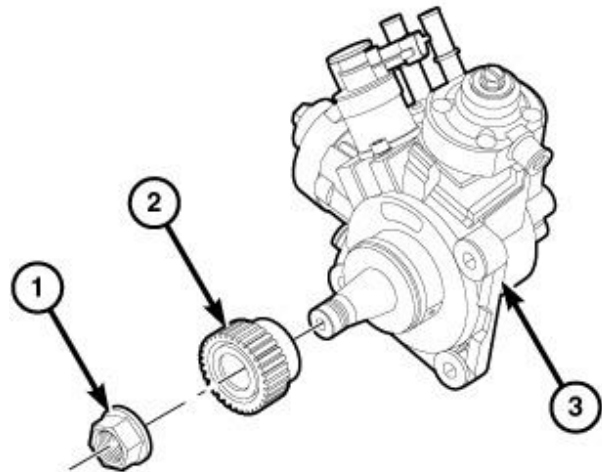


Figure 74 - Gear Removal and Installation

# SAFETY RECALL

NORTH AMERICA

## High Pressure Fuel Pump



Reference: Z46 / NHTSA 22V-406

FCA US LLC

**WARNING:** High-pressure lines deliver diesel fuel under extreme pressure from the injection pump to the fuel injectors. This may be as high as 2000 bar (29,008 psi). Use extreme caution when inspecting for high-pressure fuel leaks. Fuel under this amount of pressure can penetrate skin causing personal injury or death. Inspect for high-pressure fuel leaks with a sheet of cardboard. Wear safety goggles and adequate protective clothing when servicing fuel system.

**WARNING:** Observe the following precautions when working on fuel systems: No sparks, open flames or smoking. Avoid inhaling and swallowing fuel. Avoid eye and skin contact with fuel. Pour fuels only into suitable and appropriately marked containers. Wear protective clothing. Failure to observe these precautions may result in fire, explosion, property damage, and serious or fatal injury.

**CAUTION:** Do Not Force the high-pressure pump into the right timing cover or attempt to seat it by drawing it in with the bolts. The pump gear must be properly aligned with the drive gear on the camshaft before the high-pressure pump will seat on the cylinder head mounting surface. Failure to properly align drive gears will damage the high-pressure pump or camshaft drive gear.

**NOTE:** The high-pressure pump needs to be timed before it can be installed. Use a commercially available degree wheel to time the high-pressure pump.

**NOTE:** The fuel injection pump can be replaced without having to perform the entire base engine valve timing procedure. Do not rotate the pump shaft after removing from the vehicle. The alignment of the pump shaft must be measured and recorded using a commercially available degree wheel after the pump is removed and before transferring the pump gear over to the new pump. This is done to align the pump to the same position during installation. If the base engine valve timing must be performed as part of the repair (Refer to 09 - Engine/Valve Timing/Standard Procedure).

11. Install a **NEW** O-ring seal (1) to the fuel injection pump (Figure 75).
12. Install the gear (2) and **NEW** nut (1) onto the **NEW** fuel injection pump (3) and tighten the nut (1) finger tight (Figure 74).

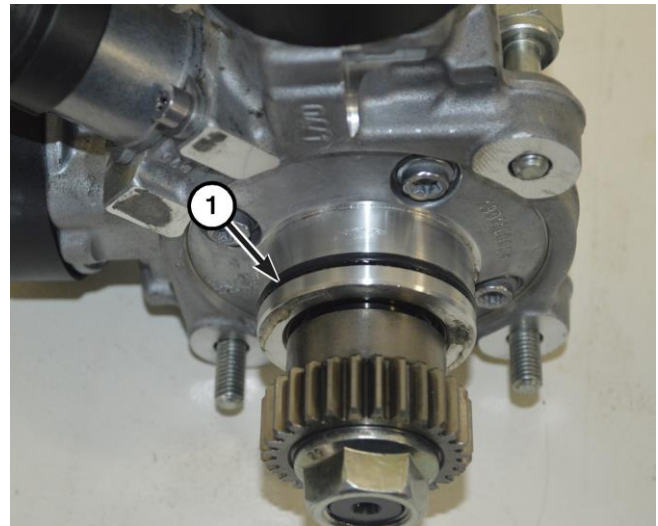


Figure 75 – HPFP O-ring

# SAFETY RECALL

NORTH AMERICA

## High Pressure Fuel Pump



Reference: Z46 / NHTSA 22V-406

FCA US LLC

13. Using a commercially available spanner wrench (2) such as Blue Point APS351B or equivalent and tighten the nut (1) to 50 N·m (37 Ft. Lbs.) (Figure 76).
14. Install the degree wheel with the zero in line with the fuel quantity solenoid and rotate the pump shaft so that the hole aligns with the reference mark on the degree wheel referenced during the removal of the pump (Figure 73).
15. Install the Tool, High Pressure Pump Installation VM.10345 into the upper bolt locations in the upper timing cover and install the HPFP to the engine (Figure 71).
16. Install the lower fuel injection pump (2) and hand tighten the bolt (1) (Figure 72).
17. Remove the Tool, High Pressure Pump Installation VM.10345 from the upper bolts location and install the bolts (Figure 71).
18. Tighten the bolts that secure the fuel injection pump to 25 N·m (18 Ft. Lbs.).
19. Connect the fuel injection pump electrical connector (2) (Figure 70).
20. Connect the low-pressure fuel supply and return lines (3) (Figure 70).
21. Install the **NEW** fuel rail supply tubes (Refer to 14 - Fuel System/Fuel Delivery/TUBE(S), Fuel/Removal and Installation).
22. Install the fuel injection pump cover (2) and tighten the screws (1) securely (Figure 69).
23. Install the cover and secure with the retainers (Figure 68).
24. Raise the vehicle.



**Figure 76 – Spanner Wrench and Drive Gear on the HPFP**

# SAFETY RECALL

NORTH AMERICA

## High Pressure Fuel Pump

Reference: Z46 / NHTSA 22V-406



FCA US LLC

25. Loosen the drain plug (1) and drain the fuel filter/water separator (2) into a suitable container (Figure 78).
26. Securely tighten the drain plug (1) (Figure 78).
27. Using a commercially available oil filter strap wrench, remove the filter cover (2) and the fuel filter (Figure 78).

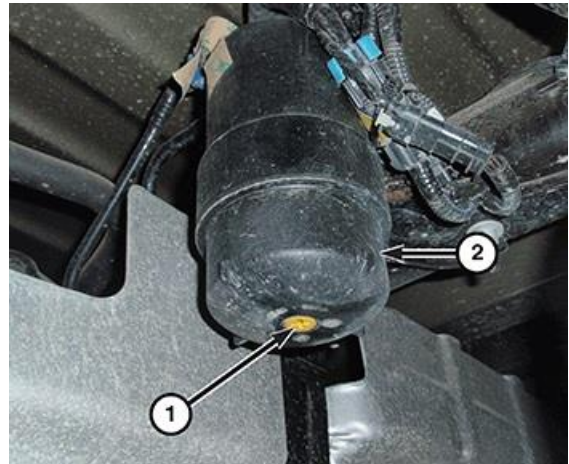


Figure 78 – Fuel Filter Drain Plug

28. While holding the fuel filter cover (3), pull up on the fuel filter (1) to separate from cover (3) (Figure 79).
29. Lubricate and install a **NEW** O-ring seal (2) onto the filter covers (3) (Figure 79).
30. Position and push down on the **NEW** fuel filters (2) to install filter onto the cover (3) (Figure 79).
31. Lubricate the rubber grommet seal with clean diesel fluid.
32. Using a commercially available oil filter strap wrench, install the fuel filter and tighten the cover (3) to 25 N·m (18 ft. lbs.).
33. Remove the support and lower the vehicle.
34. Connect the negative battery cable(s) (Refer to 08 - Electrical/Battery System/Standard Procedure).
35. Prime the fuel system (Refer to 14 - Fuel System/Fuel Delivery/Standard Procedure) .
36. Start engine and check for leaks.



Figure 79 – Fuel Filter

# SAFETY RECALL

NORTH AMERICA

## High Pressure Fuel Pump

Reference: Z46 / NHTSA 22V-406



FCA US LLC

### SERVICE PROCEDURE - DS

For vehicles with a contaminated fuel system, use the procedure below.

#### H. Replace HPFP – Contaminated System

**WARNING:** Observe the following precautions when working on fuel systems: No sparks, open flames or smoking. Avoid inhaling and swallowing fuel. Avoid eye and skin contact with fuel. Pour fuels only into suitable and appropriately marked containers. Wear protective clothing. Failure to observe these precautions may result in fire, explosion, property damage, and serious or fatal injury.

**WARNING:** High-pressure fuel lines deliver fuel under extreme pressure from the injection pump to the injectors. This may be as high as 1800 bar (26,106 psi). Use extreme caution when inspecting for high-pressure fuel leaks. Inspect high-pressure fuel leaks with a sheet of cardboard. Wear safety goggles and adequate protective clothing when servicing fuel system. Fuel under this amount of pressure can penetrate skin causing serious or fatal injury.

**NOTE:** The fuel injection pump can be replaced without having to perform the entire base engine valve timing procedure. This procedure gives instruction on how to remove and install the new fuel injection pump without performing the base engine timing. Do not rotate the pump shaft after removing from the vehicle. The alignment of the pump shaft must be measured and recorded using a commercially available degree wheel after the pump is removed and before transferring the pump gear over to the new pump. This is done to align the pump to the same position during installation. If the base engine valve timing must be performed as part of the repair, refer to Service Library 09 - Engine/Valve Timing/Standard Procedure.

**NOTE:** When key is cycled to the off position, fuel system pressure automatically bleeds down.

1. Disconnect and isolate the negative battery cable(s).
2. Remove the retainers (1) that secure the cover (2) for the high-pressure fuel pump (Figure 80).

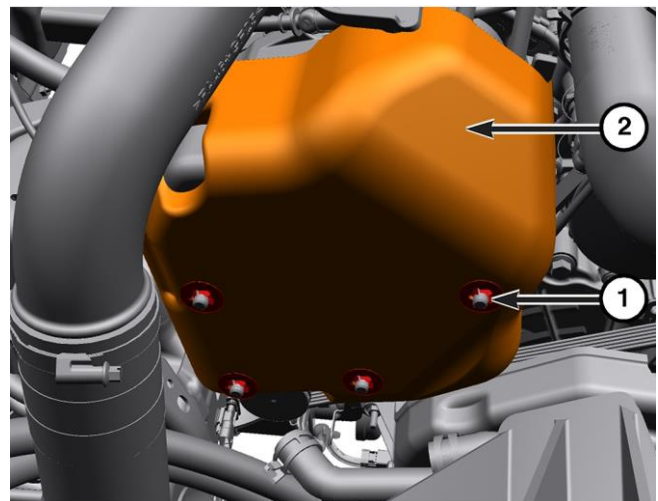


Figure 80 – HPFP Cover

# SAFETY RECALL

NORTH AMERICA

## High Pressure Fuel Pump



Reference: Z46 / NHTSA 22V-406

FCA US LLC

3. Remove the bolts (1) securing the sound proofing (2) to the fuel injection pump (Figure 81).

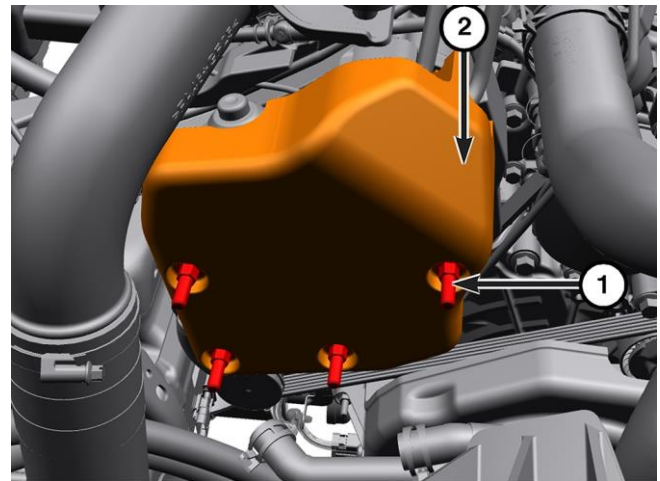


Figure 81 – HPFP Sound Proofing

4. Remove the fuel rail supply tubes (1, 4) (Refer to 14 - Fuel System/Fuel Delivery/TUBE(S), Fuel/Removal and Installation) (Figure 82).
5. Disconnect the low-pressure fuel supply lines (3) (Figure 82).
6. Disconnect the fuel quantity solenoid wire harness connector (2) (Figure 82).

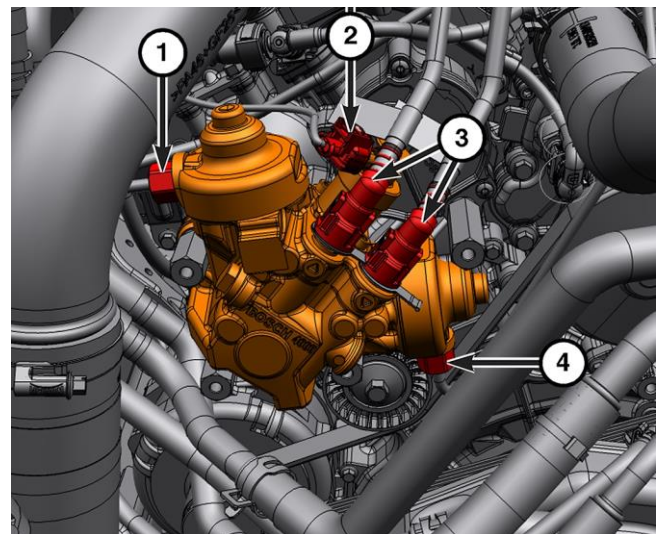


Figure 82 – HPFP Tubes and Lines

**NOTE: The fuel injection pump can be replaced without having to perform the entire base engine valve timing procedure. Do not rotate the pump shaft after removing from the vehicle. The alignment of the pump shaft must be measured and recorded using a commercially available degree wheel after the pump is removed and before transferring the pump gear over to the new pump. This is done to align the pump to the same position during installation. If the base engine valve timing must be performed as part of the repair (Refer to 09 - Engine/Valve Timing/Standard Procedure).**

# SAFETY RECALL

NORTH AMERICA  
High Pressure Fuel Pump



Reference: Z46 / NHTSA 22V-406

FCA US LLC

7. Remove the upper bolts (1) from the high-pressure pump (2) (Figure 83).
8. Using Tool, High Pressure Pump Installation VM.10345 Install the studs in the upper locations.

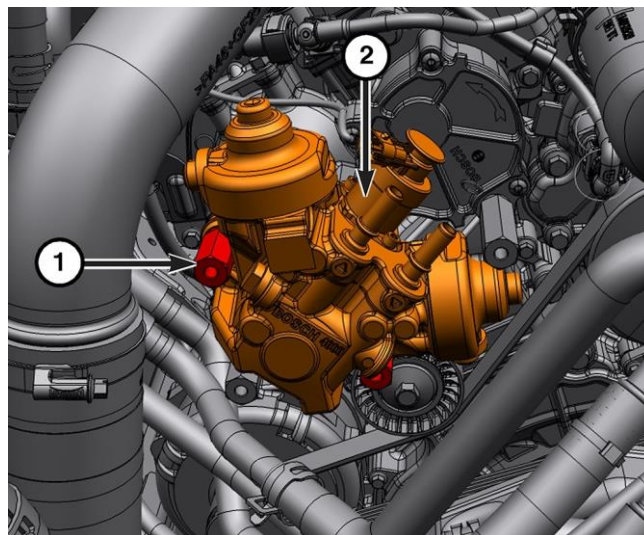


Figure 83 – HPFP Upper Bolts

9. Remove the lower bolt (1) from the HPFP and remove it from the vehicle (Figure 84).

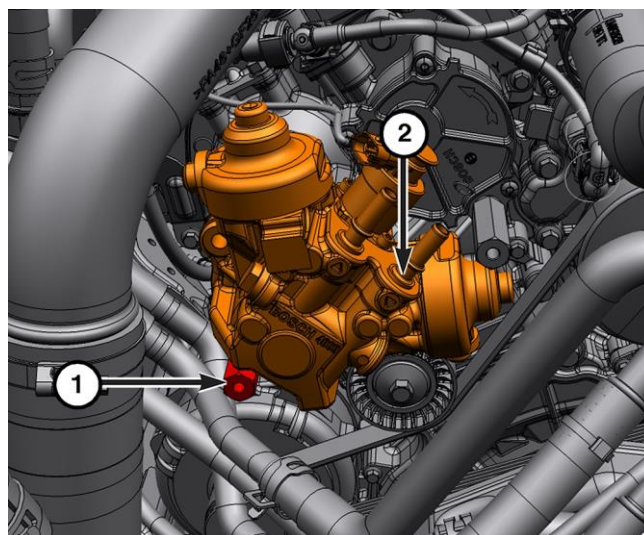


Figure 84 – HPFP Lower Bolts

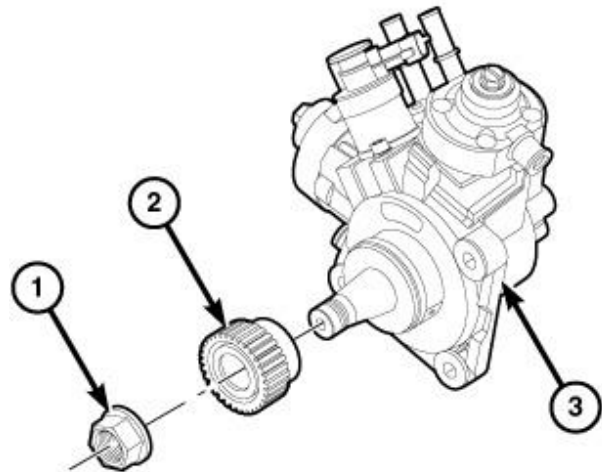


10. Install the degree wheel onto the pump and record the position of the hole in the gear on the degree wheel (Figure 85).



**Figure 85 – – Installing a Printed Paper Degree Wheel from the Internet**

**NOTE:** The use of Puller 1023 or a commercially available gear puller is required to remove the fuel injection pump gear (2) (Figure 86).



**Figure 86 - Gear Removal and Installation**

# SAFETY RECALL

NORTH AMERICA

## High Pressure Fuel Pump



Reference: Z46 / NHTSA 22V-406

FCA US LLC

11. Remove the Fuel Tubes from the engine (all 6 injector tubes, right and left fuel tubes, and the crossover tube). See 14 - Fuel System / Fuel Delivery, Diesel / TUBE(S), Fuel / Removal / FUEL TUBES.
12. Remove the fuel injector return lines from the injectors. See 14 - Fuel System / Fuel Delivery, Diesel / TUBE(S), Fuel / Removal / FUEL INJECTOR RETURN LINES.
13. Remove all 6 fuel injectors and clean the injector bores. See 14 - Fuel System / Fuel Injection, Diesel / INJECTOR(S), Fuel / Removal / LEFT BANK and RIGHT BANK.
14. Remove the fuel rails. See 14 - Fuel System / Fuel Delivery, Diesel / RAIL, Fuel / Removal / LEFT FUEL RAIL and RIGHT FUEL RAIL.
15. Install **NEW** fuel rails. See 14 - Fuel System / Fuel Delivery, Diesel / RAIL, Fuel / Installation / LEFT FUEL RAIL and RIGHT FUEL RAIL.
16. Install all 6 **NEW** fuel injectors. See 14 - Fuel System / Fuel Injection, Diesel / INJECTOR(S), Fuel / Installation / LEFT BANK and RIGHT BANK.
17. Install the fuel injector return lines to the injectors. See 14 - Fuel System / Fuel Delivery, Diesel / TUBE(S), Fuel / Installation / FUEL INJECTOR RETURN LINES.
18. Install the **NEW** Fuel Tubes to the engine (all 6 injector tubes, right and left fuel tubes, and the crossover tube). See 14 - Fuel System / Fuel Delivery, Diesel / TUBE(S), Fuel / Installation / FUEL TUBES.

**WARNING: High-pressure lines deliver diesel fuel under extreme pressure from the injection pump to the fuel injectors. This may be as high as 2000 bar (29,008 psi). Use extreme caution when inspecting for high-pressure fuel leaks. Fuel under this amount of pressure can penetrate skin causing personal injury or death. Inspect for high-pressure fuel leaks with a sheet of cardboard. Wear safety goggles and adequate protective clothing when servicing fuel system.**

**WARNING: Observe the following precautions when working on fuel systems: No sparks, open flames or smoking. Avoid inhaling and swallowing fuel. Avoid eye and skin contact with fuel. Pour fuels only into suitable and appropriately marked containers. Wear protective clothing. Failure to observe these precautions may result in fire, explosion, property damage, and serious or fatal injury.**

**CAUTION: Do Not Force the high-pressure pump into the right timing cover or attempt to seat it by drawing it in with the bolts. The pump gear must be properly aligned with the drive gear on the camshaft before the high-pressure pump will seat on the cylinder head mounting surface. Failure to properly align drive gears will damage the high-pressure pump or camshaft drive gear.**

**NOTE: The high-pressure pump needs to be timed before it can be installed. Use a commercially available degree wheel to time the high-pressure pump.**

**NOTE: The fuel injection pump can be replaced without having to perform the entire base engine valve timing procedure. Do not rotate the pump shaft after removing from the vehicle. The alignment of the pump shaft must be measured and recorded using a commercially available degree wheel after the pump is removed and before transferring the pump gear over to the new pump. This is done to align the pump to the same position during installation. If the base engine valve timing must be performed as part of the repair (Refer to 09 - Engine/Valve Timing/Standard Procedure).**

# SAFETY RECALL

NORTH AMERICA

## High Pressure Fuel Pump



Reference: Z46 / NHTSA 22V-406

FCA US LLC

**NOTE:** The fuel injection pump can be replaced without having to perform the entire base engine valve timing procedure. Do not rotate the pump shaft after removing from the vehicle. The alignment of the pump shaft must be measured and recorded using a commercially available degree wheel after the pump is removed and before transferring the pump gear over to the new pump. This is done to align the pump to the same position during installation. If the base engine valve timing must be performed as part of the repair (Refer to 09 - Engine/Valve Timing/Standard Procedure).

19. Install a **NEW** O-ring seal (1) to the fuel injection pump (Figure 87).

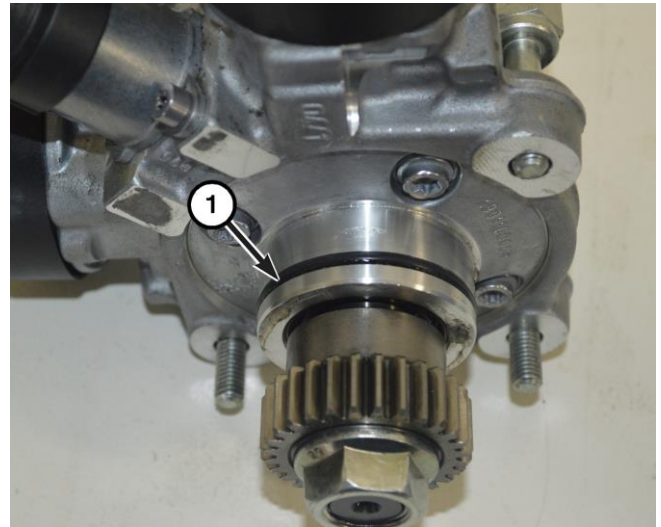


Figure 87 – HPFP O-ring

20. If removed, install the gear (2) and nut (1) onto the fuel injection pump (3) and tighten the nut (1) finger tight (Figure 86).
21. Using a commercially available spanner wrench (2) such as Blue Point APS35IB or equivalent and tighten the nut (1) to 50 N·m (37 Ft. Lbs.) (Figure 88).



Figure 88 – Spanner Wrench and Drive Gear on the HPFP

# SAFETY RECALL

NORTH AMERICA

## High Pressure Fuel Pump



Reference: Z46 / NHTSA 22V-406

FCA US LLC

22. Install the degree wheel and rotate the pump shaft so that the hole aligns with the reference mark on the degree wheel that was recorded after the removal of the pump (Figure 85).
23. Install the Tool, High Pressure Pump Installation VM.10345 into the studs installed in the upper timing cover and install the HPFP to the engine (Figure 83).
24. Install the lower fuel injection pump (2) and hand tighten the bolt (1) (Figure 83).
25. Remove the Tool, High Pressure Pump Installation VM.10345 from the upper bolts location and install the bolts.
26. Tighten the bolts that secure the fuel injection pump to 25 N·m (18 Ft. Lbs.).
27. Connect the fuel injection pump electrical connector (2) (Figure 82).
28. Connect the low-pressure fuel return line (3) to the HPFP (Figure 82). **DO NOT** connect the low-pressure fuel supply line to the HPFP at this time.
29. Install the fuel rail supply tubes (1, 4) to the HPFP (Figure 82). Refer to 14 - Fuel System/Fuel Delivery/TUBE(S), Fuel/Removal and Installation.
30. Connect the negative battery cable(s). (Refer to 08 - Electrical/Battery System/Standard Procedure).
31. Remove all fuel from the fuel tank. Refer to 14 - Fuel System/Fuel Delivery - Standard Procedure. Use an appropriate fuel container. Dispose of the contaminated fuel using the proper procedures.

**CAUTION: Dispose of petroleum-based products in a manner consistent with all applicable Local, State, Federal, and Provincial regulations.**

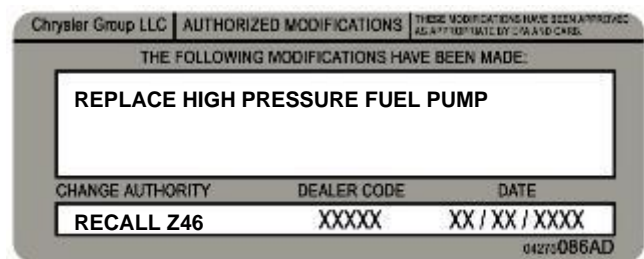
32. Remove the fuel tank. Refer to 14 - Fuel System/Fuel Delivery/TANK, Fuel - Removal.
33. Remove the Fuel Pump Module. Refer to 14 - Fuel System / Fuel Delivery, Diesel / MODULE, Fuel Pump / Removal.
34. Ensure the swirl pot indentation below the in-tank electric fuel pump inlet is completely drained of any contaminated fuel and thoroughly clean the fuel tank.
35. Install the **NEW** fuel filter. Refer to 14 - Fuel System / Fuel Delivery, Diesel / FILTER, Fuel / Removal.
36. Install the **NEW** Fuel Pump Module. Refer to 14 - Fuel System / Fuel Delivery, Diesel / MODULE, Fuel Pump / Installation.
37. Install the fuel tank. **DO NOT** connect the low-pressure return line at this time. Fill the tank with clean diesel fuel.
38. Connect a clean hose to the low-pressure supply line fitting at the HPFP and place the other end in a suitable clean container.
39. Turn the ignition **ON** and collect the fuel escaping from the low-pressure supply line into a clean container.
40. Connect the low-pressure supply line to the HPFP.

41. Connect a clean hose to the low pressure return line fitting at the tank and place the other end in a suitable clean container.
42. Turn the ignition **ON** and collect the fuel escaping from the low pressure return into a clean container.
43. Install the fuel injection pump cover (2) and tighten the screws (1) securely (Figure 81).
44. Install the cover and secure with the retainers (Figure 80).
45. Start engine and check for leaks.

**NOTE: For all platforms above and both contaminated and non-contaminated systems, complete step I. Install the Authorized Modifications Label.**

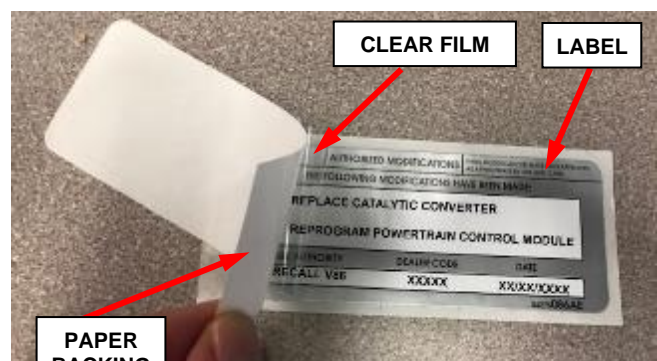
**I. Install the Authorized Modifications Label:**

1. Type or print (with a ballpoint pen) the necessary information shown in (Figure 89) onto the authorized modifications Label.



**Figure 89 – Authorized Modifications Label**

2. Remove the paper backing from the clear film on the front of the authorized modifications label then carefully apply the clear film over the front of the authorized modifications label (Figure 90).



**Figure 90 – Apply Clear Film**

**NOTE: The Authorized Modifications Label should be located near the Vehicle Emission Control Information (VECI) label (Figure 91).**

3. Locate the VECI label on the underside of the engine compartment hood (Figure 91).

**NOTE: For vehicles missing a VECI label, locate a flat protected area on the underside of the hood to apply the authorized modifications label.**

4. Clean the surface near the VECI label with isopropyl alcohol or equivalent and a soft cloth.



**Figure 91 – Apply Authorized Modifications Label Near VECI Label  
(Specific Vehicle May Look Different)**

5. Remove the authorized modifications label from its paper backing.
6. Apply the authorized modifications label next to the VECI label (Figure 65).
7. Firmly press and smooth the authorized modifications label to ensure good adhesion.
8. Close the engine compartment hood.
9. Complete the Proof of Correction Form for California Residents, **Section J**.

## **J. Complete Proof of Correction Form for California Residents:**

This recall is subject to the **State of California Registration Renewal/Emissions Recall Enforcement Program**. Complete a Vehicle Emission Recall Proof of Correction Form (**Form No. 81-016-1053**) and **supply it to vehicle owners residing in the state of California** for proof that this recall has been performed when they renew the vehicle registration.

Process Steps to obtain the California Proof of Correction form:

- a. Access the “**DealerCONNECT**” website.
- b. Select the “**Service**” tab.
- c. Under the “**Publications**” heading, select the “**ePublishing**” link.
- d. Sign in using your **Dealer Code** and **Password**.
- e. Select the “**Proof of Correction form**”.

## **K. Owner’s Manual Addendum and Tip Card:**

From Campaign kit CSFP01A1AA, place the Owner’s Manual Addendum in the glovebox with the Owner’s Manual.

Place the Tip Card in a conspicuous location that will be visible to the driver so that they will review it. Suggestions would be the top of the instrument panel, in front of the instrument cluster, etc. Please review the information on the card with the owner when the vehicle is returned to them.

## **L. Fuel Door Label:**

**NOTE: Do not apply the label over an existing label. Apply the label on a flat surface on the inside of the fuel door. For example, on the top of the fuel door hinge (Figure 67).**

From Campaign kit CSFP01A1AA, install the fuel door decal.

1. Open the fuel door.
2. Clean the top surface of the hinge with isopropyl alcohol or equivalent and a soft cloth. Repeat as needed until the soft cloth comes off the surface clean.
3. Remove the fuel door label from its paper backing.



**Figure 66 – Fuel Door Label**

# SAFETY RECALL

NORTH AMERICA

## High Pressure Fuel Pump



Reference: Z46 / NHTSA 22V-406

FCA US LLC

4. Apply the fuel door label (Figure 66) to the top of the fuel door hinge (Figure 67).
5. Firmly press and smooth the fuel door label to ensure good adhesion.
6. Close the fuel door.

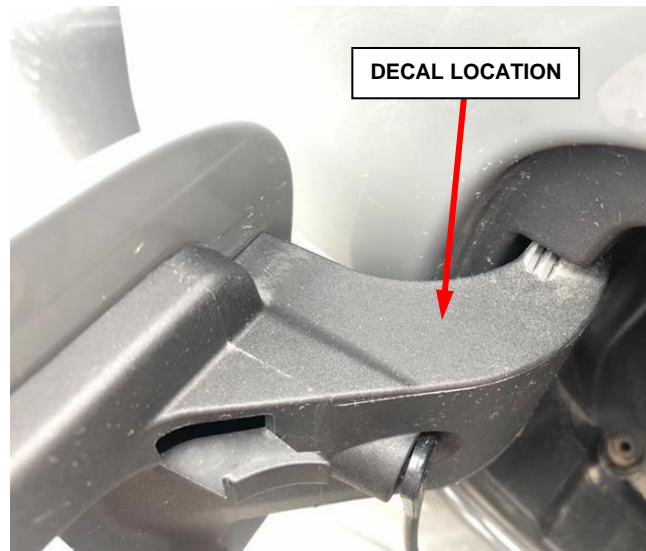


Figure 67 – Fuel Door Hinge Location



This notice applies to your vehicle,

[Model Year and Model]

VIN XXXXXXXXXXXXXXXXXXXX

Z46/NHTSA 22V-406

LOGO

VEHICLE PICTURE

#### YOUR SCHEDULING OPTIONS

- 1. RECOMMENDED OPTION**  
Call your authorized Chrysler / Dodge / Jeep® / RAM Dealership.
- 2. Call the FCA Recall Assistance Center at 1-800-853-1403.** An agent can confirm part availability and help schedule an appointment.
- 3. Visit recalls.mopar.com, scan the QR code below, or download the Mopar Owner's Companion App.**

QR Code

Get access to recall notifications, locate your nearest dealer, and more through this website or Mopar Owner's Companion App. You will be asked to provide your Vehicle Identification Number (VIN) to protect and verify your identity. The last eight characters of your VIN are provided above.

#### DEALERSHIP INSTRUCTIONS

Please reference Safety Recall Z46.

# IMPORTANT SAFETY RECALL

## High Pressure Fuel Pump

Dear [Name],

This notice is sent to you in accordance with the National Traffic and Motor Vehicle Safety Act.

FCA US LLC has decided that a defect, which relates to motor vehicle safety, exists in certain [2014-2019 (DS) Ram 1500 Pickup and 2014-2020 (WK) Jeep® Grand Cherokee] vehicles.

It is extremely important to take steps now to repair your vehicle to ensure the safety of you and your passengers.

#### WHY DOES MY VEHICLE NEED REPAIRS?

The High-Pressure Fuel Pump (HPFP) on your vehicle <sup>[1]</sup> that could fail prematurely. A HPFP failure may introduce internally failed component debris into the fuel system potentially causing fuel starvation. **Fuel starvation may result in an unexpected loss of motive power, which can cause a vehicle to crash without prior warning.**

#### HOW DO I RESOLVE THIS IMPORTANT SAFETY ISSUE?

FCA US will repair your vehicle <sup>[2]</sup> free of charge (parts and labor). To do this, your dealer will replace the HPFP, and inspect and, if necessary, replace additional fuel system components. The estimated repair time is two to eight hours. In addition, your dealer will require your vehicle for proper check-in, preparation, and check-out during your visit, which may require more time. Your time is important to us, so we recommend that you schedule a service appointment to minimize your inconvenience. Please bring this letter with you to your dealership.

**TO SCHEDULE YOUR FREE REPAIR,  
CALL YOUR CHRYSLER, DODGE, JEEP OR RAM DEALER TODAY**

#### CALIFORNIA RESIDENTS

The State of California requires the completion of emission recall repairs prior to vehicle registration renewal. Your dealer will provide you with a Vehicle Emission Recall Proof of Correction Form after the Safety Recall service is performed. Be sure to save this form since the California Department of Motor Vehicles may require that you supply it as proof that the Safety Recall has been performed.

In order to ensure your full protection under the emissions warranty provisions, it is recommended that you have your vehicle serviced as soon as possible. Failure to do so could be determined as lack of proper maintenance of your vehicle.

#### WHAT IF I ALREADY PAID TO HAVE THIS REPAIR COMPLETED?

If you have already experienced this specific condition and have paid to have it repaired, you may visit [www.fcarecallreimbursement.com](http://www.fcarecallreimbursement.com) to submit your reimbursement request online. <sup>[3]</sup> Once we receive and verify the required documents, reimbursement will be sent to you within 60 days. If you have had previous repairs performed and/or already received reimbursement, you may still need to have the recall repair performed.

We apologize for any inconvenience, but are sincerely concerned about your safety. Thank you for your attention to this important matter.

Customer Assistance/Field Operations  
FCA US LLC



**Mr. Mrs. Customer**  
**1234 Main Street**  
**Hometown, MI 48371**

[1] If you no longer own this vehicle, please help us update our records. Call the FCA Recall Assistance Center at 1-800-853-1403 to update your information.

[2] If your dealer fails or is unable to remedy this defect without charge and within a reasonable time, you may submit a written complaint to the Administrator, National Highway Traffic Safety Administration, 1200 New Jersey Ave., S.E., Washington, DC 20590, or you can call the toll-free Vehicle Safety Hotline at 1-888-327-4236 (TTY 1-800-424-9153), or go to [safercar.gov](http://safercar.gov).

[3] You can also mail in your original receipts and proof of payment to the following address for reimbursement consideration: FCA Customer Assistance, P.O. Box 21-8004, Auburn Hills, MI 48321-8007, Attention: Recall Reimbursement.

Note to lessors receiving this recall notice: Federal regulation requires that you forward this recall notice to the lessee within 10 days.