

## FIELD INSTALLATION INSTRUCTIONS

### PTO Timer Module Relocation

#### Tools required:

- Basic shop equipment (Screwdrivers, Wrenches, Drill, Etc.).
- Wire Strippers, Flush Cuts, Wire Crimpers, Butane Torch.
- Safety glasses and gloves

#### Hardware Provided by Reading:

- InPower RXP-0202-SPC593 10 second off delay PTO timer module.
- Fusible Link (included in the harness)
- PTO Timer Module Harness CA-RX-01.
- 4 - 16-14 AWG Water Proof Butt Splices.
- 2 – 6” Zip Ties.

**Note:** All images in this document are for reference purposes only.

It is the installer's responsibility to ensure all OEM chassis equipment, body and/or products are not damaged during set-up or installation.



Replacement PTO Timer Module

#### PTO Timer Module Replacement Steps:

- 1) Disconnect the negative terminal of the chassis battery. If there is more than one battery, disconnect the negative terminal on every battery.
- 2) Locate the Original PTO Timer Module under the hood. It will be on the passenger side near the upfitter relay box.
- 3) Without removing any of the wiring, unmount the module.

- 4) Record the colors and locations of each of the four wires connected to the Original PTO Timer Module in the table below (FIGURE 1).  
If two or more wires share the same color, mark each wire with the terminal number where it is connected. If two wires connect to the same terminal and are different colors, record both wire colors to that terminal number.

FIGURE 1

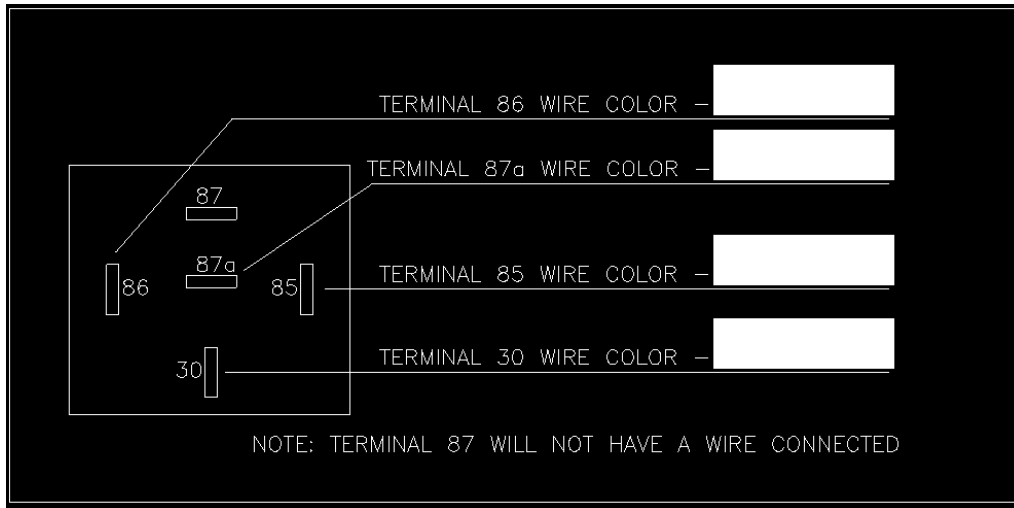

- 5) Cut the wires free that run to the Original PTO Timer Module.  
Make the cuts close to the connector on the Timer Module.  
Set the Original PTO Timer Module and connector to the side. It will not be reinstalled.
- 6) Connect the new harness to the wires that were cut loose from the Original PTO Timer Module. Follow the diagram below (Figure 2). Use the sealed butt splices that were provided with the new harness. Heat the splices to make a watertight connection.

FIGURE 2

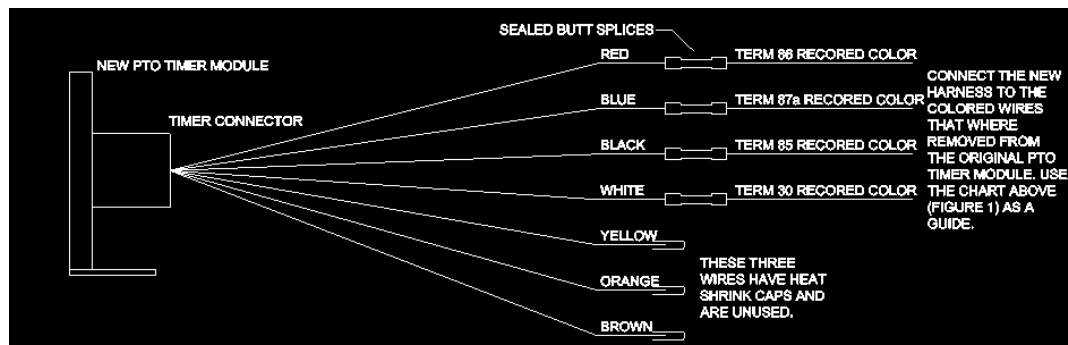

- 7) Mount the new timer with the timer connector facing down.
- 8) Secure the spliced wires with zip ties.
- 9) Reconnect the negative battery cables.

10) Verify that the engine remote start stop are functioning correctly and that the PTO will restart after a 10-second delay.

11) Complete and submit the form on the next page to.

Email: [bverbonitz@readingtruck.com](mailto:bverbonitz@readingtruck.com) or [Kmillier@readingbody.com](mailto:Kmillier@readingbody.com)

12) Return the original PTO timer module via call tag.

**COMPONENT INSTALLATION VERIFICATION**

Date: \_\_\_\_\_ Body Serial Number: \_\_\_\_\_ VIN Number: \_\_\_\_\_  
(Complete VIN)

Installer: \_\_\_\_\_  
Address: \_\_\_\_\_  
\_\_\_\_\_

City: \_\_\_\_\_ State: \_\_\_\_\_ Zip: \_\_\_\_\_

Phone: \_\_\_\_\_ Contact: \_\_\_\_\_

**The undersigned hereby certify that the original PTO timer module was replaced with a new InPower RXP-0202-SPC593 timer module and harness that was installed in conformance with these Field Installation Instructions, tested after installation and performed as expected. The installation process was done by a qualified technician in a workman like manner without damage to the OEM chassis equipment, body and/or associated products.**

Technician: Name: \_\_\_\_\_  
Signature: \_\_\_\_\_

Supervisor: Signature: \_\_\_\_\_

**Once installed and tested please scan and email this page to:**

Attention: Brian Verbonitz, Warranty Manager or Kiley Miller, Warranty Supervisor  
Email: [bverbonitz@readingtruck.com](mailto:bverbonitz@readingtruck.com) or [KMiller@readingbody.com](mailto:KMiller@readingbody.com)

**Contact Details**  
**Reading Truck Warranty**  
Phone: 717 445 1179 (Brian Verbonitz)  
Phone: 610 406 6017 (Kiley Miller)