

ModulT Gen2 ADB Caliper Pad Retainer and Spring Bracket Inspection and Repair.

Overview:

- This work instruction demonstrates how to inspect and repair the pad retainer spring bracket to ensure proper installation.
- This inspection can be performed with the wheel on.
- These instructions demonstrate inspecting both Super Single and Dual tire configurations.
- In the event the pad retainer is missing, tire removal may be required to repair the spring bracket and pad retainer.

**For Support Contact Haldex Technical Services at:
Phone 800-643-2374 / 816-891-2470
TechServices.KansasCity@haldex.com**

ModulT Gen2 ADB Caliper Pad Retainer and Spring Bracket Inspection and Repair.

Contents:

- 1. Fault description**
- 2. Inspection procedure on super single tires**
- 3. Inspection procedure from outside the trailer on dual tire configuration**
- 4. Inspection procedure from under the trailer on dual tire configuration**
- 5. Reference**
- 6. Repair procedure**
- 7. Actions if there are missing or damaged components**
- 8. Contact information**

Fault Description

The spring bracket (1) may be trapped under the pad retainer (2).

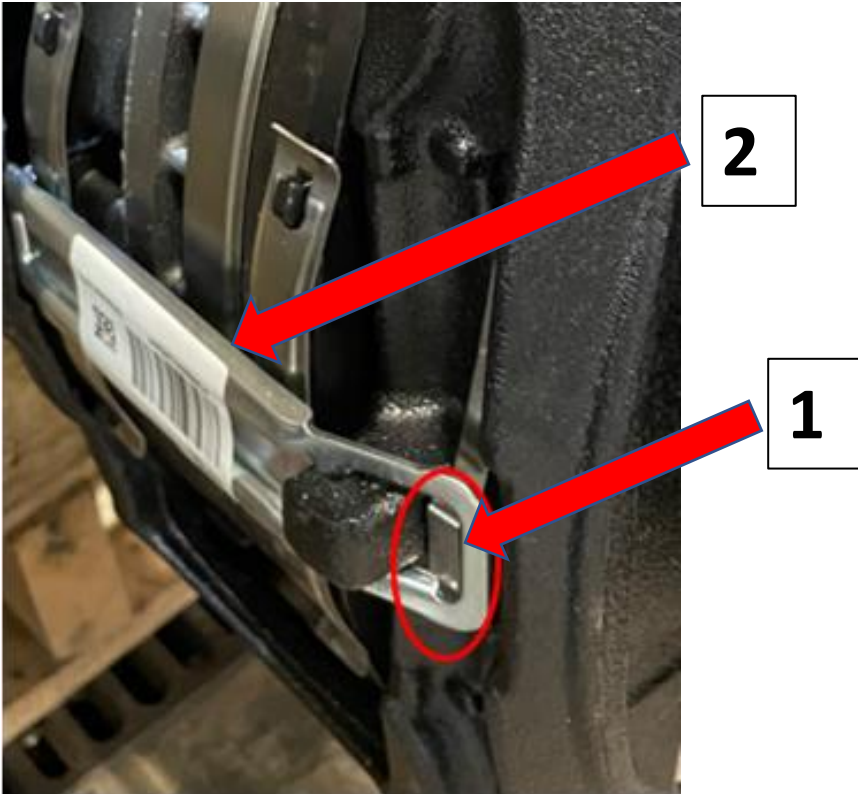

This photo shows the spring bracket (1) trapped under the pad retainer (2)



Super Single Spring Bracket Inspection

- The spring bracket is easily visible and physically accessible under the trailer.
- Ensure the clip fully extends through the pad retainer bar slot. There should be a full opening at the top of the spring bracket.

Dual Tire Spring Bracket Inspection: Outside the Trailer



Pictured as seen through the rim face.

Dual Tires:

There are two methods to inspect the spring bracket: Either Outside the trailer, or under the trailer.

Outside the trailer, facing the rim:

1. Look through the rim holes to ensure the spring bracket fully exceeds the pad retainer.
2. You may need to rotate the wheel to align a rim hole and caliper.
3. You can also utilize a bore scope to view these components.
4. There should be a full opening at the top of the bracket.

Dual Tire Spring Bracket Inspection: Under the Trailer



Dual Tires, Under the Trailer:

1. Use a borescope to look through the back of the rim to ensure the spring bracket fully exceeds the pad retainer.
2. There should be a full opening at the top of the spring bracket.

Pictured as seen with a borescope from behind the wheel, under the trailer.

Repair Procedure

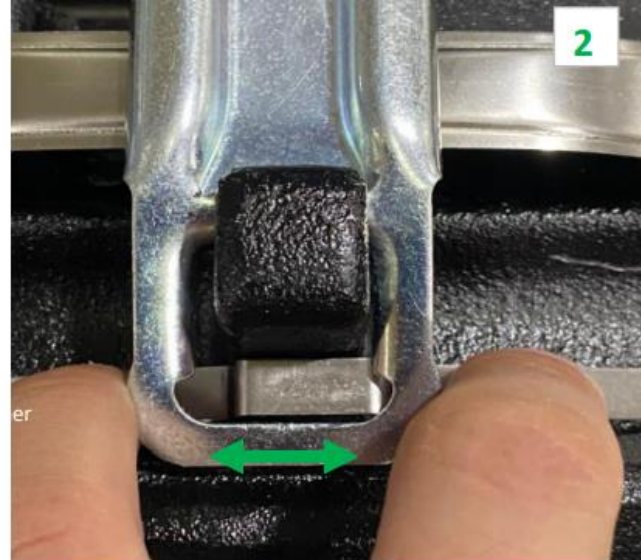
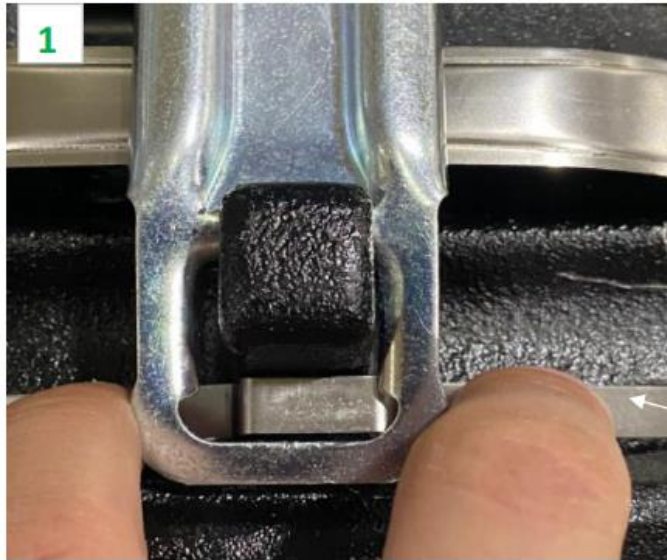

- 1. If the spring bracket is not fully extended, you may need to remove the wheel assembly to access the bracket. Use appropriate tire removal and safety procedures compliant with your organization and tire removal instruction.**
- 2. Use your fingers or a screwdriver to shift the pad retainer until the spring seats into the proper location.**

Actions if there are missing or damaged components

If during the inspection you find any missing or damaged ADB components related to this matter:

1. Place the Vehicle Out of Service.
2. For replacement, Perform the procedure shown in the next several pages.
3. Replace any other components that were damaged as a result of this situation.
4. Process a warranty claim in accordance with the attached warranty policy or your organization's warranty policy.

Replacement instructions and more can be found in Haldex Installation Guide L30051. Please download this manual from Web Address of Service Manual:

<https://www.haldex.com/globalassets/north-america/documents/air-disc-brakes/l30051.pdf>

**For Support Contact Haldex Technical Services at:
Phone 800-643-2374 / 816-891-2470
TechServices.KansasCity@haldex.com**

Caliper Replacement Procedure

Step 1: Tire Removal

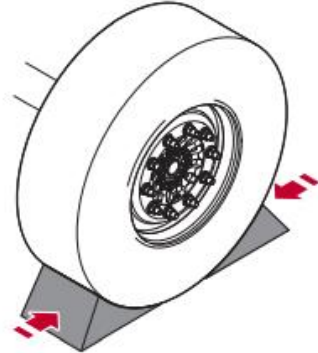

Blocking the wheels.

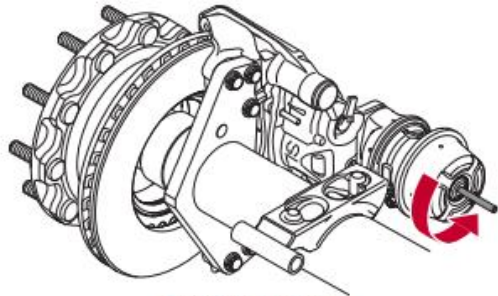

Release parking brake.

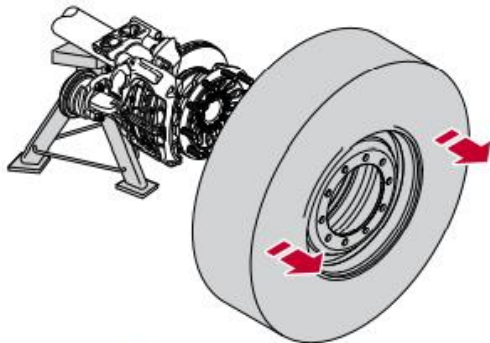

Remove tire / wheel assembly.

Warning Personal safety equipment must be worn when working with equipment.

Lift up and support the vehicle axle to remove the tire / wheel assembly in accordance with the axle or vehicle recommendations.

1. On a flat even surface, block the wheels
2. Lift the axles and place on jack stands.
3. Release the parking brake.
4. Check for free rolling resistance of the tire / wheel assembly. If the resistance is higher than expected, tap the tire to remove the rest tension. If the wheel still does not rotate freely then further inspection is needed.
5. Remove the lug nuts.
6. Remove the tire / wheel assembly

Caliper Replacement Procedure

Step 2: Brake Pad Removal

- Using a T55 Torx, manually turn the reset shaft counterclockwise to de-adjust the brake so that the thrust plate fully retracts to its inner position.
 - An audible clicking sound will be felt and heard when de-adjusting. The stop of the fully retracted inner thrust plate position must be distinct, but do not exceed 15 ft-lbs. (20Nm) in torque or leave it tightened in this position.
- Remove the pad retainer (B) by first pushing and holding down the spring bracket (A), while the spring bracket is held down, slide in and remove the pad retainer. A tool can be used to help slide in the pad retainer if unable to remove by hand.
- Remove the two pad springs (C).
- Remove the brake pads. Always remove the outer brake pad first (D), followed by the inner brake pad (E). a. The inner brake pad back plate locates on two holes which mate to the thrust plate, therefore the pad cannot be removed with the outer pad still being in place. Once the outer pad is removed, the caliper can be slid laterally to allow for the inner pad removal (E).
- Remove the pad retainer spring bracket (A)

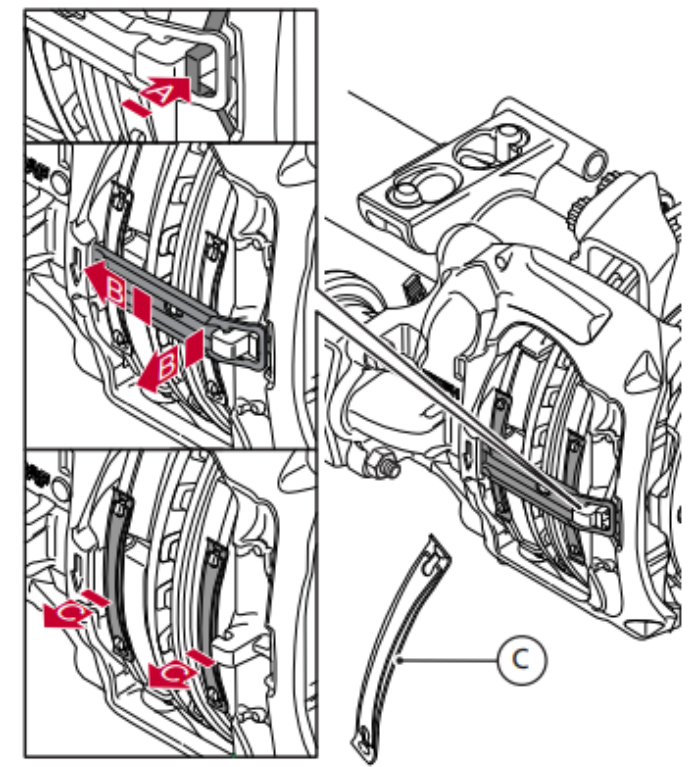

Remove pad retainer and pad springs.

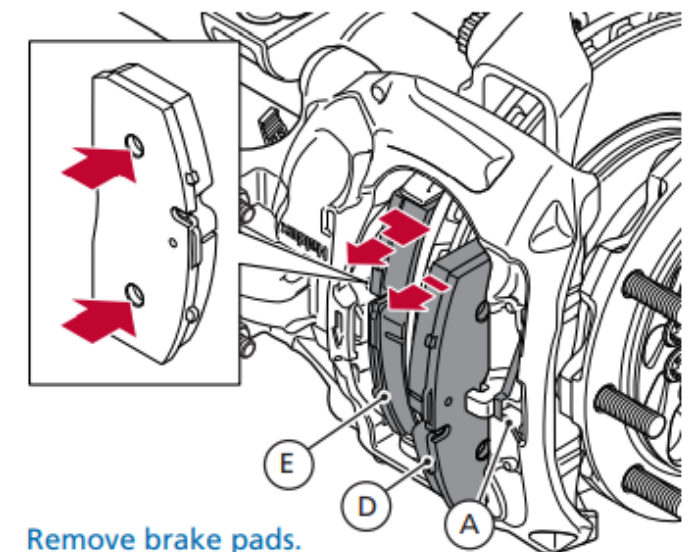

Remove brake pads.

Caliper Replacement Procedure

Step 3: Brake Chamber Removal

1. Carefully clean around the mating surfaces of the brake chamber (A) and the caliper (B) to ensure that dirt does not get into the mechanism area when removing the brake chamber.
2. If applicable, ensure that the spring brake chamber (F) is fully disengaged and mechanically secured in the released position.
3. Ensure that the brake chamber (A) is depressurized.
4. Mark and remove the hose connections of the service brake (C) and if applicable the parking brake (D).
5. Remove the two nuts (E) holding the brake chamber. Remove the brake chamber (A) from the caliper (B)

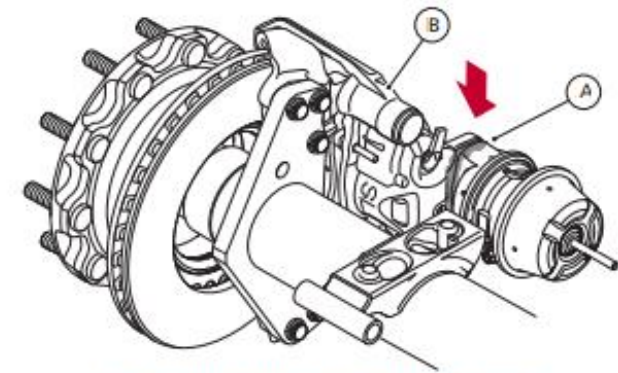

Clean mating surfaces of brake and chamber.

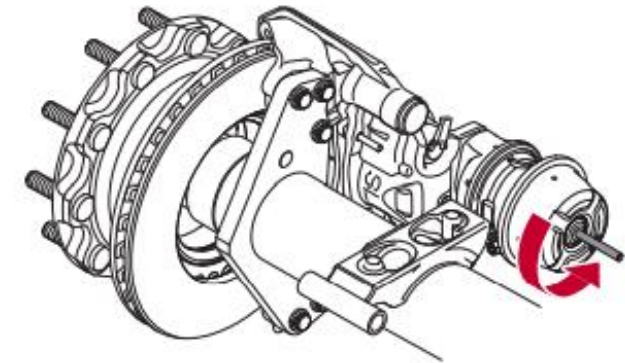

Secure brake chamber in the released position.

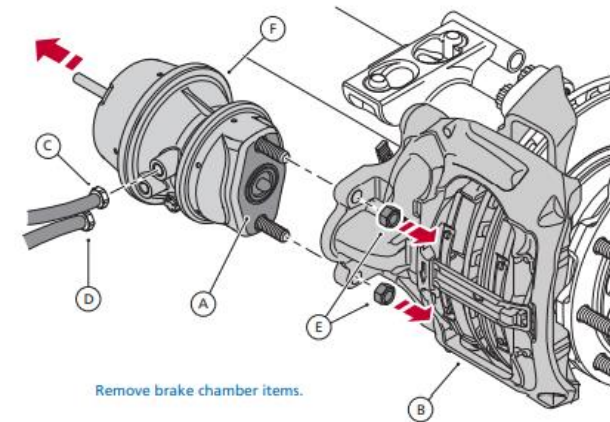

Remove brake chamber items.

Caliper Replacement Procedure

Step 4: Caliper Removal

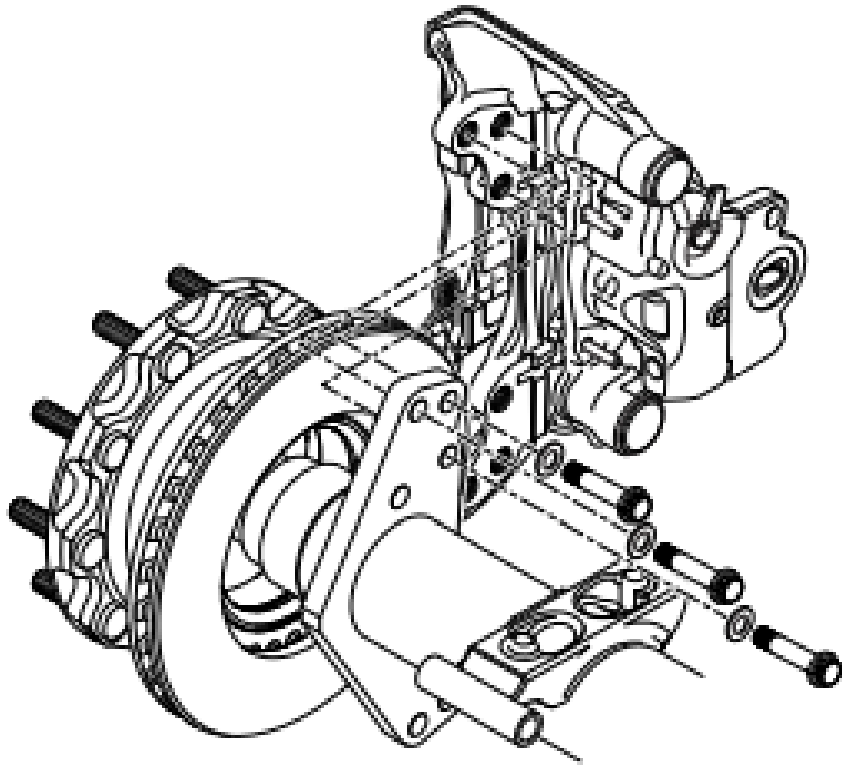

1. Loosen bolts with long wrench, one at a time, ensuring top bolt is still supporting caliper.
2. Confirm the caliper is supported.
3. Remove the bolts completely.

Caliper Replacement Procedure

Step 5: Caliper Installation

Never reuse bolts

1. Starting with top bolt, re-install the caliper onto the brake spider using proper bolts for the specific carrier design. **Never reuse bolts and check for proper length.**

Refer to the next page for bolt kit numbers. Too long of bolt can bottom out on Rotor.

- a. Pre-torque bolts using clocking numbers and recommended pre-torque setting for size of bolts. Refer to Table 1 on page 12.
- b. Verify the pre-torque of the bolts a second time, and if necessary, re-tighten to recommended settings, Table 1, page 12
- c. For final Torque specifications refer to Table 1, page 12, Carrier bolt section. Care must be taken to match size of bolt and whether dry or lubricated for proper torque.

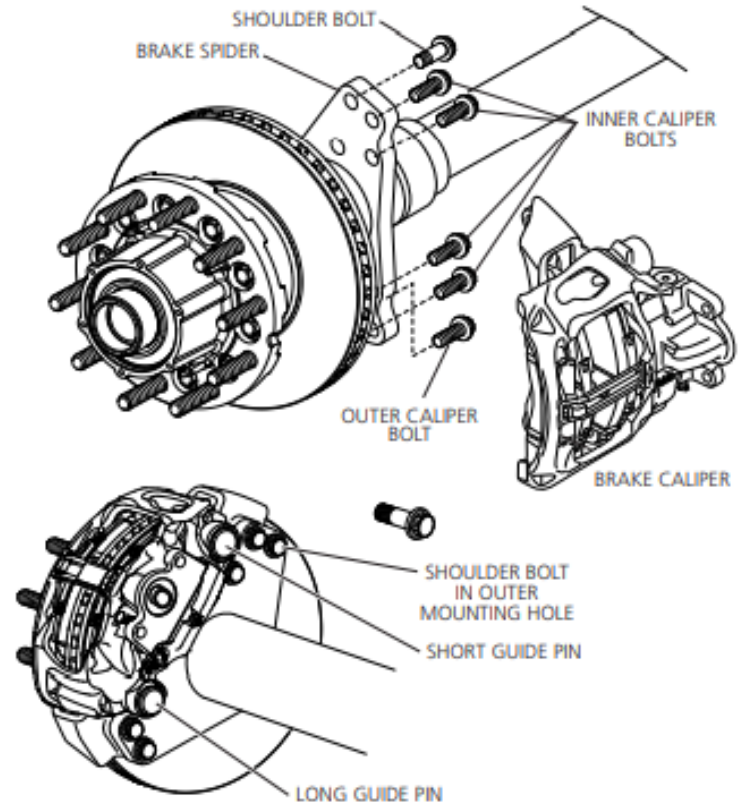
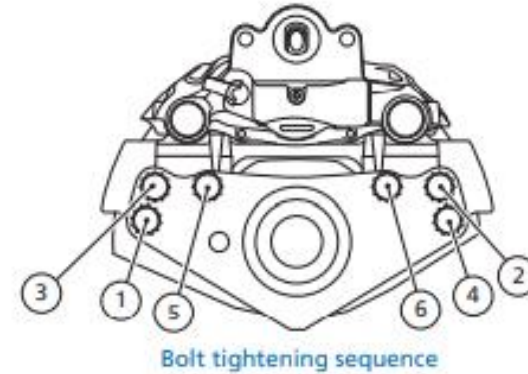

Caliper Replacement Procedure

Bolt Kit Part Numbers

790-22060 Bolt Kit M20X55mm 790-22062 Bolt Kit M16X55mm
 790-22063 Bolt Kit M20X60mm 790-22067 Bolt Kit M16X60mm
 790-22068 Bolt Kit M16X60mm 790-22069 Bolt Kit M18X55mm

Tightening Torques

Brake chamber fixation nuts..... 130 ft-lbs ± 22 ft-lbs (180 ± 30 Nm)

Carrier bolt(s).....331 ft-lbs ± 22 ft-lbs (450 ± 30 Nm)

Torque Tightening

Screw Thread	Offset (mm)	Pre-Torque		(Dry)		(Lubricated)	
		N-m	FT-LBS	N-m	FT-LBS	N-m	FT-LBS
M20x2.5	56	200	145	675±34	500 ±25	530±34	390±25
M16x1.5	55	95	70	350±34	255±25	275±34	200±25
M18x1.5	65	120	88	450±30	331±22	350±30	258±22

Torque Plates

Width (Inches)	Screw Length (mm)	Washer Thickness (mm)
1	55	3.5 ±0.5
1.225	60	3.5 ±0.6

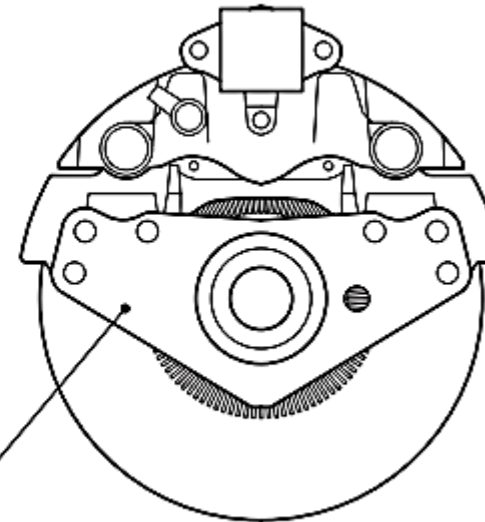

Caliper Replacement Procedure

Step 6: Chamber Installation

1. Ensure the brake chamber being installed is the correct one for the application and vehicle. If a spring brake chamber is being installed, ensure that the parking brake spring is caged in accordance with the manufacturer's instructions.
2. Ensure the surface of the caliper that mates with the brake chamber is free from dirt, moisture and corrosion. Do the same check on the brake chambers mating face (A) and seal. Ensure the brake chamber seal is in the correct position and not damaged.
3. Apply a small amount of general-purpose grease in the ball cup of the brake chamber lever. Do not overfill the cup or let grease fall inside the brake.
4. Fit the new brake chamber (A) to the caliper (B) with nuts (E). Screw the nuts home first before torque tightening to ensure the brake chamber seats parallel.

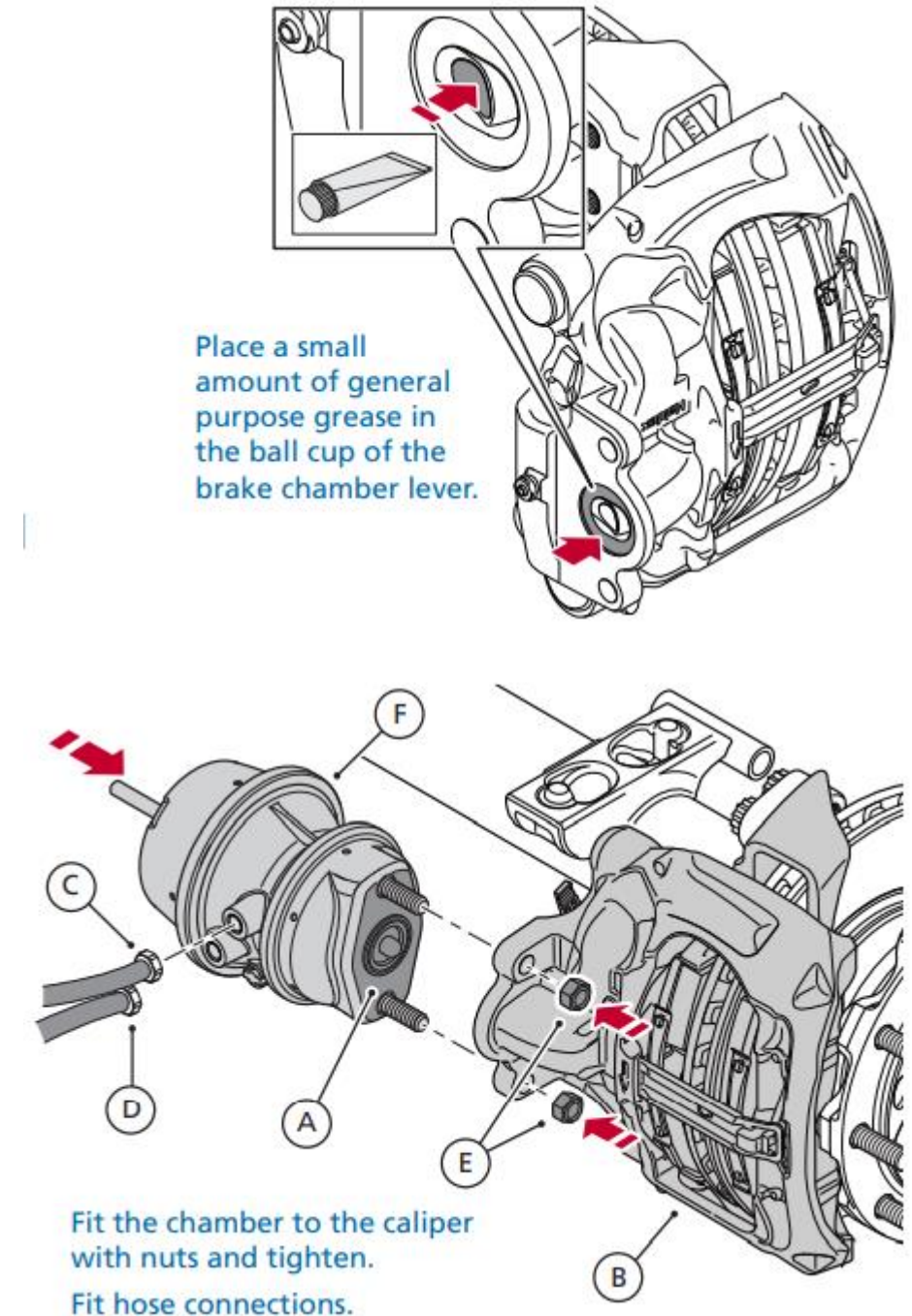

Caliper Replacement Procedure

Step 6: Chamber Installation (continued)

5. Brake chamber fixation nut tightening torque is 130 ft-lbs. \pm 15 ft-lbs. (180 \pm 20 Nm). Follow the vehicle/axle manufacturers recommendations.

6. Fit the brake chamber hose connection of the service brake (C) and if applicable the parking brake (D). If fitting both hoses, ensure connections (C) and (D) are the correct way around.

7. Remove the ventilation drain plug that faces downwards from the service brake housing and if applicable, also from the spring brake housing.

8. If applicable, release the parking brake and disengage the spring brake chamber's caging mechanism so that the spring is released. Minimum 90 psi (6 bar).

9. With the service brake engaged and, where applicable, with the parking brake released, check the brake chambers, hoses and connections for leaks or damage

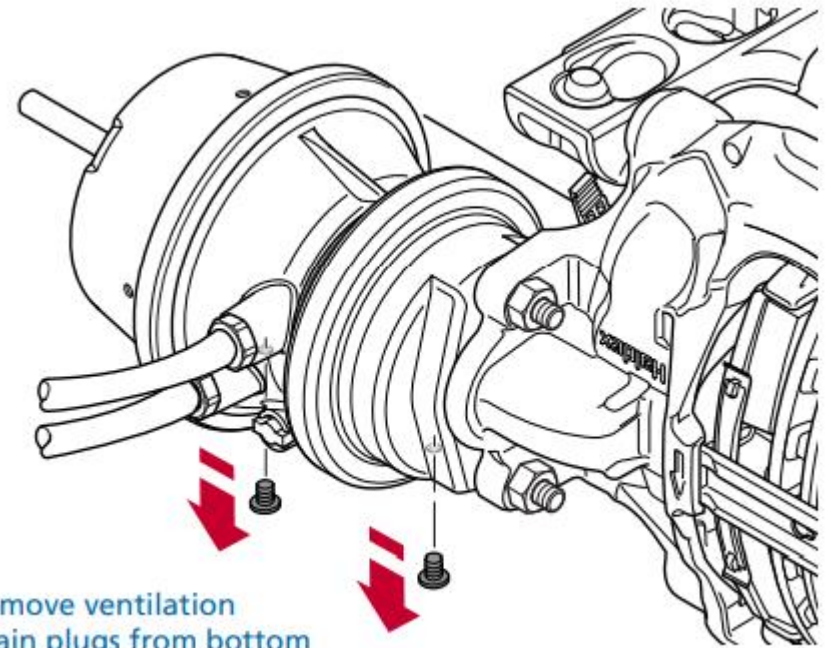

Remove ventilation
drain plugs from bottom
side of spring brake chamber.

Caliper Replacement Procedure

Step 7: Pad Installation

1. Ensure the brake caliper is fully de-adjusted before installing new brake pads.
2. Check all contact surfaces on the carrier, caliper, and thrust plate are free from dirt and corrosion. a. Clean if necessary.
3. Check abutment area on carrier for deep grooves, cracks, or deformation. a. Replace carrier if grooves exceed 3mm or has cracks and deformation.
4. Install the inner brake pad into the caliper. a. Note: The inner brake pad locates onto the thrust plate on two points.
5. Install the outer brake pad into the caliper. a. Note: Ensure the friction material faces the rotor.

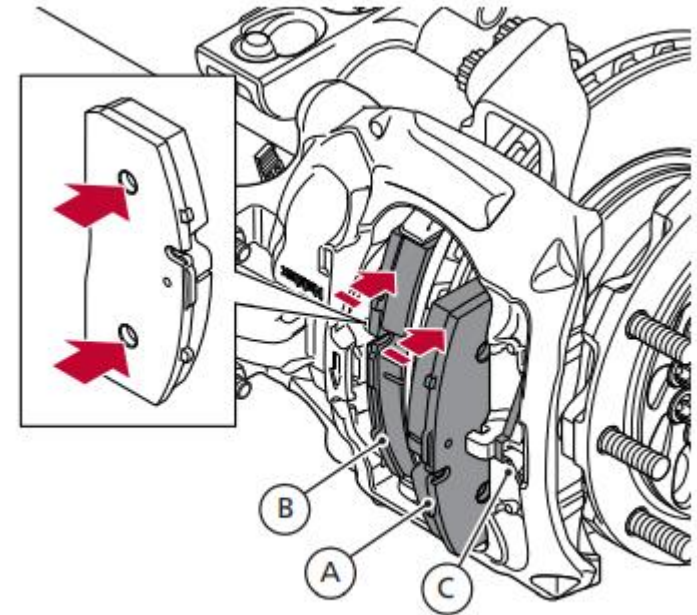

Replace brake pads.

Caliper Replacement Procedure

Step 7: Pad Installation (continued)

6. Install the new spring bracket into the caliper and ensure it is seated in the correct position.

7. Install the new pad springs and the pad retainer. a. Note: The pad retainer is fitted by first locating the pad retainer in the housing end in the caliper aperture, then compressing the pad springs and locating the pad retainer slot over the caliper latch, and finally sliding the pad retainer under the caliper latch until the spring bracket pops into its locking position. If necessary, use a tool to help push the pad retainer into position.

8. Using a T55 Torx, manually adjust the brake by turning the reset shaft clockwise until the pads touch the rotor and you feel an end stop.

9. Then turn the reset shaft counterclockwise 2 clicks. a. This procedure sets the initial brake pad clearance.

10. Fit the reset shaft protective plug into the caliper, ensure it is correctly orientated and pushed fully into its correct sealing position. Failure to do so may compromise the life of the brake.

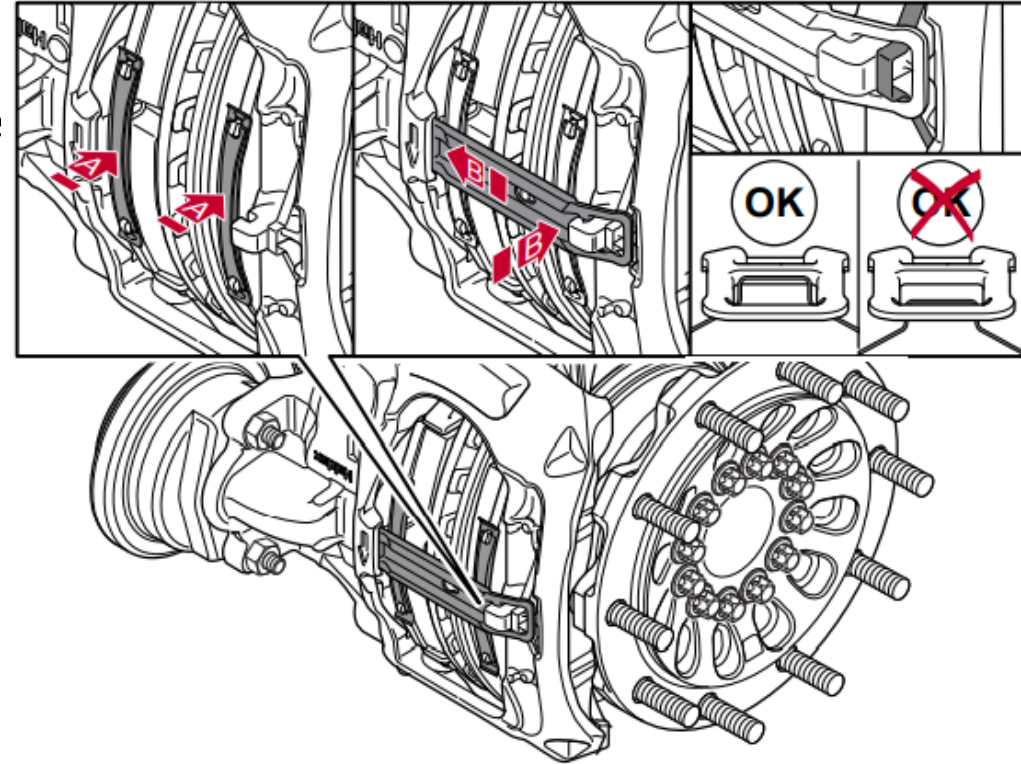

Install new pad springs and pad retainer

Caliper Replacement Procedure

Step 8: Tire Installation

Mounting

IMPORTANT! Make sure that the brake hoses are in good condition, that they are layed/ducted and fastened correctly.

1. Check the free rolling resistance. The disc brake must not be obstructed in any way.
2. 2. Mount the wheel.

IMPORTANT! If the disc brake is equipped with a parking brake actuator, ensure that the brake system is pressurized, and the spring brake chamber is fully engaged and mechanically secured in the active position. See the vehicle manufacturer's instructions.

IMPORTANT! Apply air to the parking brake. Make sure that there is sufficient air in the system (min. 6 bar).

Lowering of the vehicle axle

1. Activate the parking brake if fitted with a spring brake chamber.
2. 2. Lift the axles so that the stands can be removed.
3. Carefully lower the vehicle to the ground.
4. Remove the wheel blocks

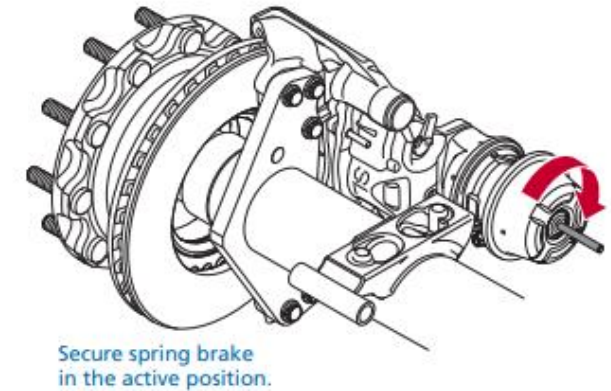
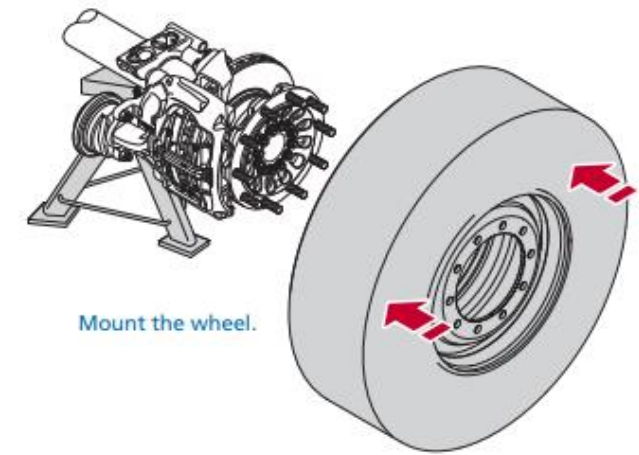

Haldex Technical Support

For Support Contact Haldex Technical Services at:

Phone 800-643-2374 / 816-891-2470

TechServices.KansasCity@haldex.com

Or

Contact your Haldex Sales Representative