



VOLUNTARY RECALL CAMPAIGN

Classification: RS22-010A	Reference: NTB22-070A	Date: July 27, 2023
------------------------------	--------------------------	------------------------

VOLUNTARY SAFETY RECALL CAMPAIGN 2001-2003 MAXIMA; FRONT PASSENGER AIR BAG INFLATOR & MODULE REPLACEMENT

This bulletin has been amended. See **AMENDMENT HISTORY** on the last page.
Please discard previous versions of this bulletin.

CAMPAIGN ID #: PC906
APPLIED VEHICLES: 2001-2003 Maxima (A33)

**Check Service COMM or Dealer Business Systems (DBS)
National Service History to confirm campaign eligibility.**

INTRODUCTION

Nissan is conducting this voluntary safety recall campaign on certain specific model year 2001-2003 Maxima vehicles to replace the front passenger air bag inflator and module. This service will be performed at no charge to the customer for parts or labor.

TK Services and RXO Logistics have issued return packaging, shipping labels, documents, and directions that must be used and followed in order to properly carry out this campaign. Information on this documentation is provided in this bulletin.

IDENTIFICATION NUMBER

Nissan has assigned identification number PC906 to this campaign. This number must appear on all communication and documentation of any nature dealing with this campaign.

DEALER RESPONSIBILITY

It is the dealer's responsibility to check Service COMM or Dealer Business Systems (DBS) National Service History for the campaign status on each vehicle falling within the range of this voluntary safety recall which for any reason enters the service department. This includes vehicles purchased from private parties or presented by transient (tourist) owners and vehicles in a dealer's inventory. **Federal law requires that new vehicles in dealer inventory which are the subject of a safety recall must be corrected prior to sale. Failure to do so can result in civil penalties by the National Highway Traffic Safety Administration.** While federal law applies only to new vehicles, Nissan strongly encourages dealers to correct any used vehicles in their inventory before they are retailed.

Bulletins are intended for use by qualified technicians, not 'do-it-yourselfers'. Qualified technicians are properly trained individuals who have the equipment, tools, safety instruction, and know-how to do a job properly and safely. **NOTE:** If you believe that a described condition may apply to a particular vehicle, DO NOT assume that it does. See your Nissan dealer to determine if this applies to your vehicle.

Repair Overview

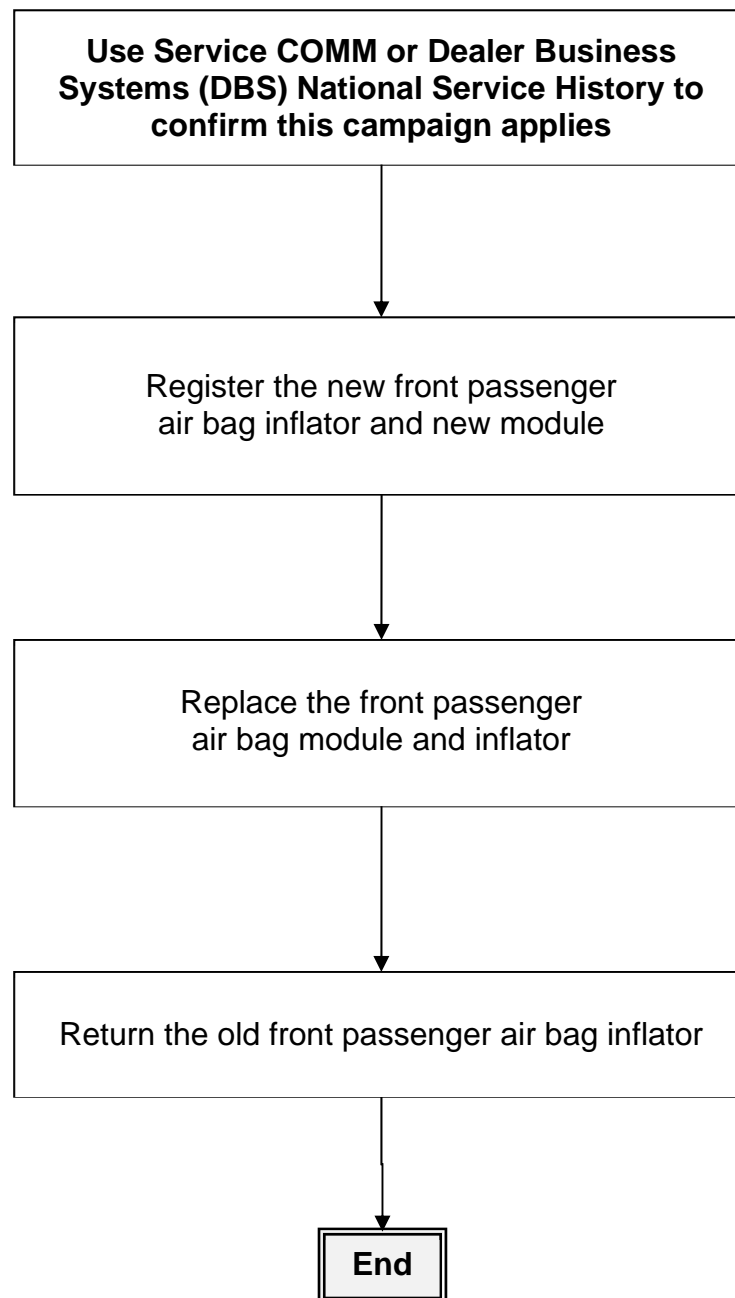

REQUIRED SPECIAL TOOLS

New or replacement Essential Tools are available from Tech Mate online: www.techmatetools.com, or by phone: 1-833-397-3493.

When ordering, keep in mind that the tool part number prefix has changed from “J” to “NI”. For example, **J-52352** is now **NI-52352**.

Quick Scan Tool (J-52352)

- Each dealer has been previously shipped one Quick Scan Tool (J-52352).



Figure 1

REQUIRED SPECIAL TOOLS (continued)

Air Bag Module Support (J-51315)

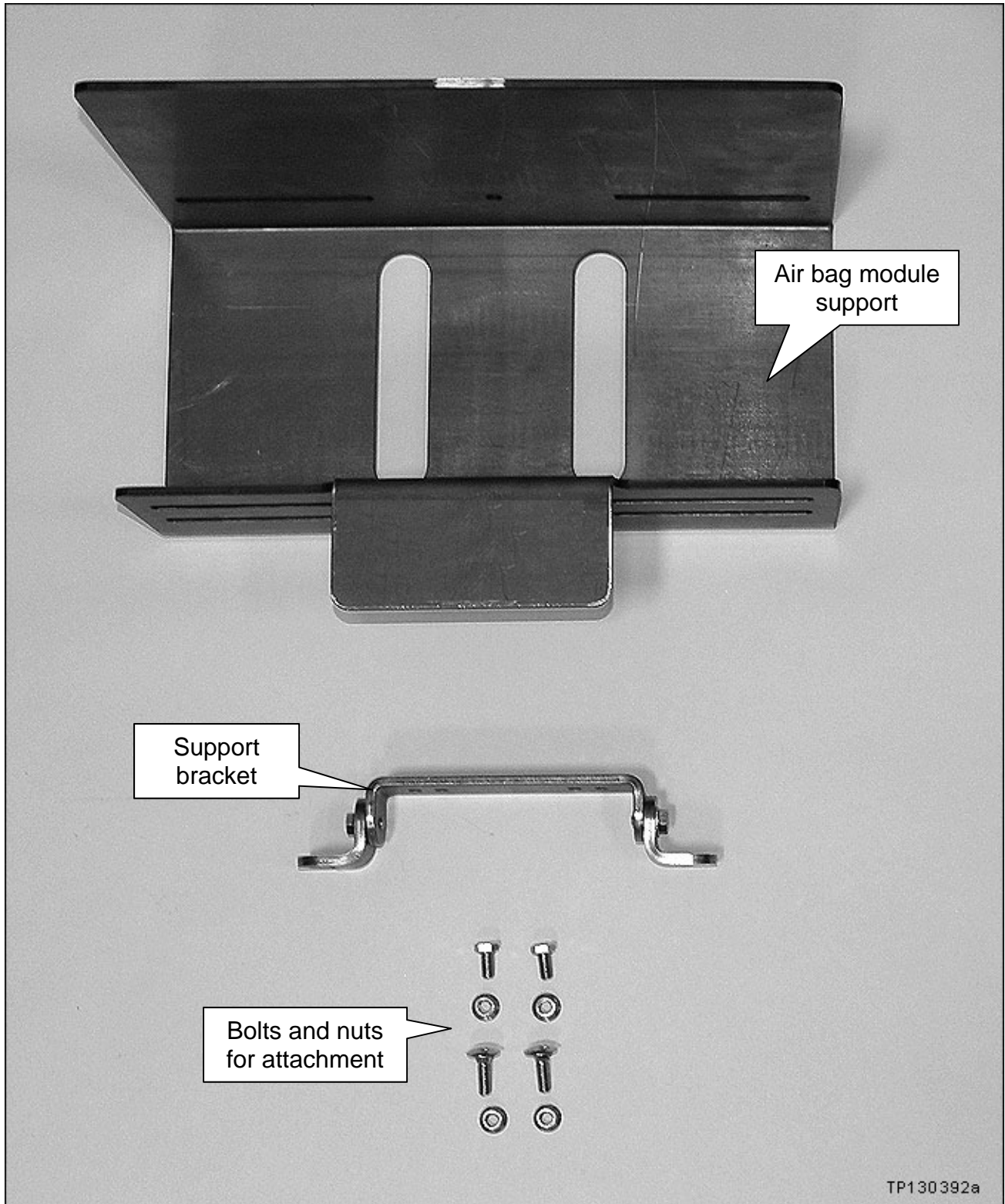

TP130392a

Figure 2

SERVICE PROCEDURE

WARNING

To avoid the risk of death or severe personal injury, follow all cautions, warnings and notes when working on or near a Supplemental Restraint System (SRS), such as an air bag.

NOTICE

To avoid damage to the vehicle, handle interior trim carefully. Work with clean hands and clean tools to avoid dirt and stains. Use protective covers as needed.

New Inflator and New Module Registration

1. Obtain a new inflator from your parts department.
 - The new inflator is listed in the **PARTS INFORMATION**.

2. Attach the Quick Scan Tool (J-52352) to your CONSULT PC USB port.

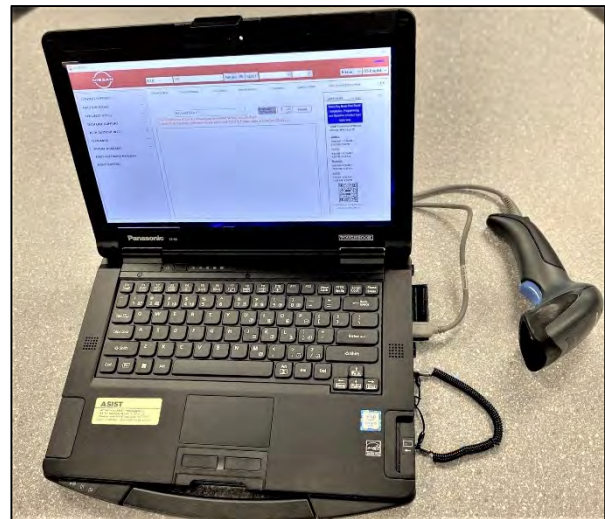

Figure 3

3. On the left side of the ASIST main menu, select **TECH SUPPORT INFO**, then **Inventory Vehicle Actions**.

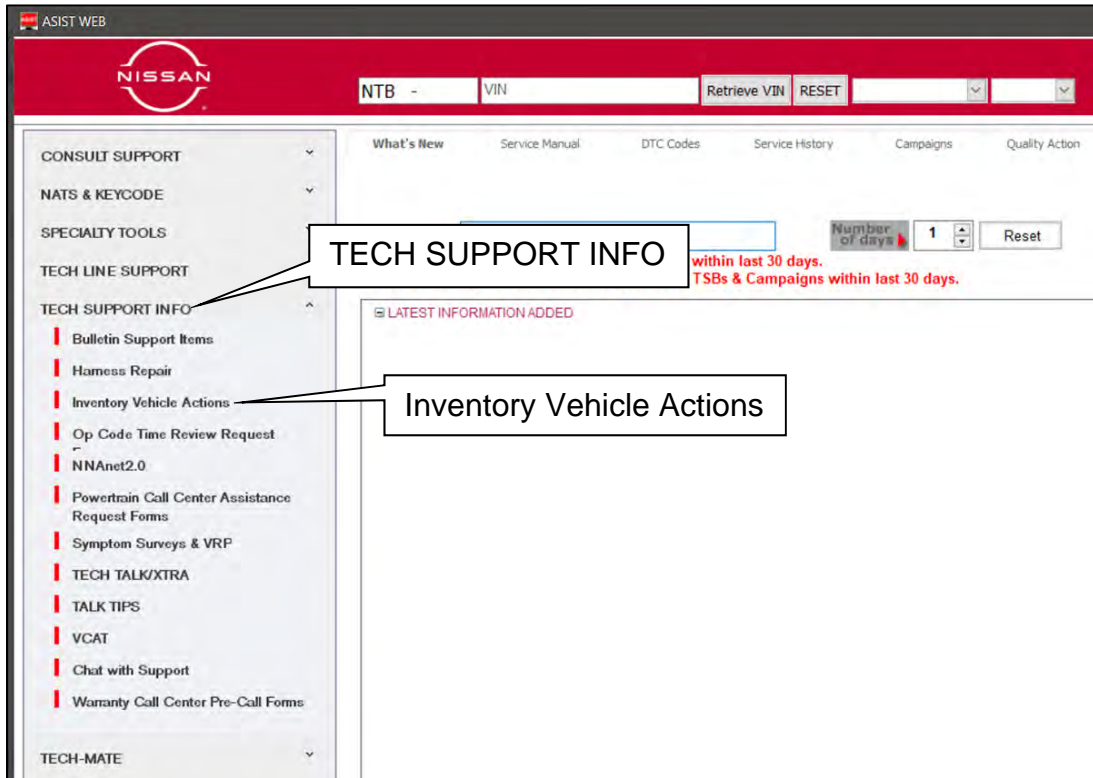

Figure 4

4. Select **CLICK HERE...** next to "Airbag to VIN Registration".

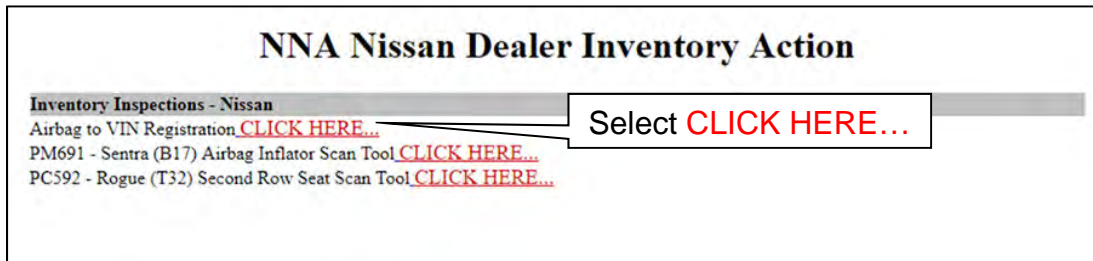

Figure 5

Register the New Inflator

5. Use the Quick Scan Tool to scan the bar code (VIN) on the B-pillar label.
 - Wipe any dirt/debris from the bar code before scanning.

HINT:

- Some labels may not scan quickly.
- Hold the Quick Scan Tool approximately six (6) inches away from the label.
- Hold the trigger down until the label is read (this may take several seconds).
- VIN will automatically populate.
- If needed, the VIN can be entered manually.



Figure 6

6. Use the Quick Scan Tool to scan the bar code (serial number) on the new inflator shipping box.
 - The serial number will automatically populate (Figure 8).
 - If needed, the serial number can be entered manually.



Figure 7

9. Open the Module shipping container.
 - New module is listed in the **PARTS INFORMATION**.

10. Locate the bar code sticker on the new module (Figure 10).
 - The new module will be left in the shipping container until later in this procedure.

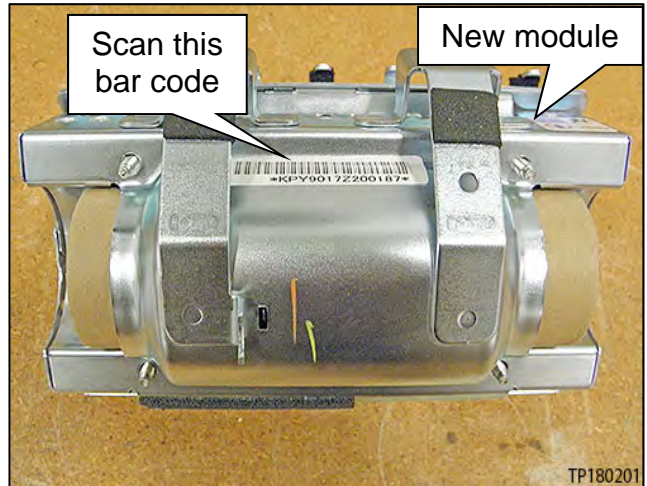

Figure 10

11. Use the Quick Scan Tool to scan the bar code (serial number) on the new module (Figure 10 and Figure 11).
 - If needed, the serial number can be entered manually.

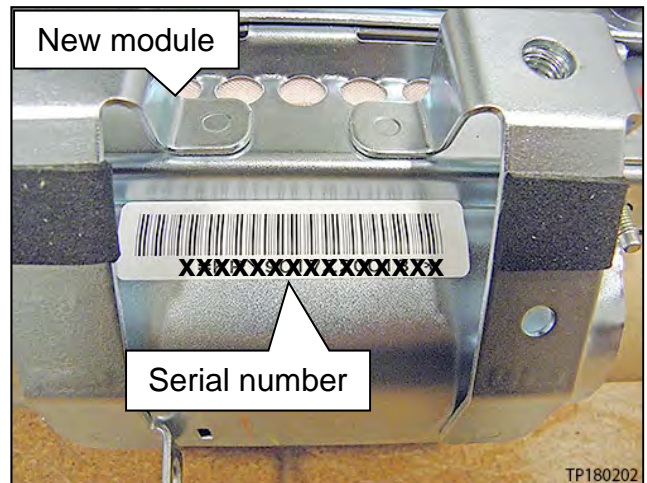

Figure 11

12. Select **Submit** on the ASIST screen.

Airbag to VIN Registration

11/28/2016 1:36:32 PM

Please enter/scan the VIN and Airbag Inflator Serial Number

Dealer Code

Key Number

VIN

Airbag Serial Number **Submit**

Select **Submit** after both fields are populated

Figure 12

Inflator and Module Replacement

⚠ WARNING

To avoid the risk of death or severe personal injury, follow all cautions, warnings and notes when working on or near a Supplemental Restraint System (SRS), such as an air bag.

NOTICE

To avoid damage to the vehicle, handle interior trim carefully. Work with clean hands and clean tools to avoid dirt and stains. Use protective covers as needed.

13. Turn the ignition ON.

14. Write down the radio settings.

Presets	1	2	3	4	5	6
AM						
FM 1						
FM 2						
SAT 1						
SAT 2						
Bass	Treble		Balance	Fade	Speed Sen. Vol.	

15. Turn the ignition OFF.

16. Disconnect both battery cables, negative cable first.

17. Wait at least 3 minutes.

18. Remove the front passenger air bag module.

- Refer to the ESM: **RS – Restraint System > SUPPLEMENTAL RESTRAINT SYSTEM (SRS) > Front Passenger Air Bag Module > REMOVAL**

19. Set the module in a clean working area.

- Do not set the module with cover facing down.

20. Securely mount the air bag module support (support) in a vise (Figure 13).
- Work from behind and to the sides of the support.
 - Wear safety glasses while performing inflator replacement.

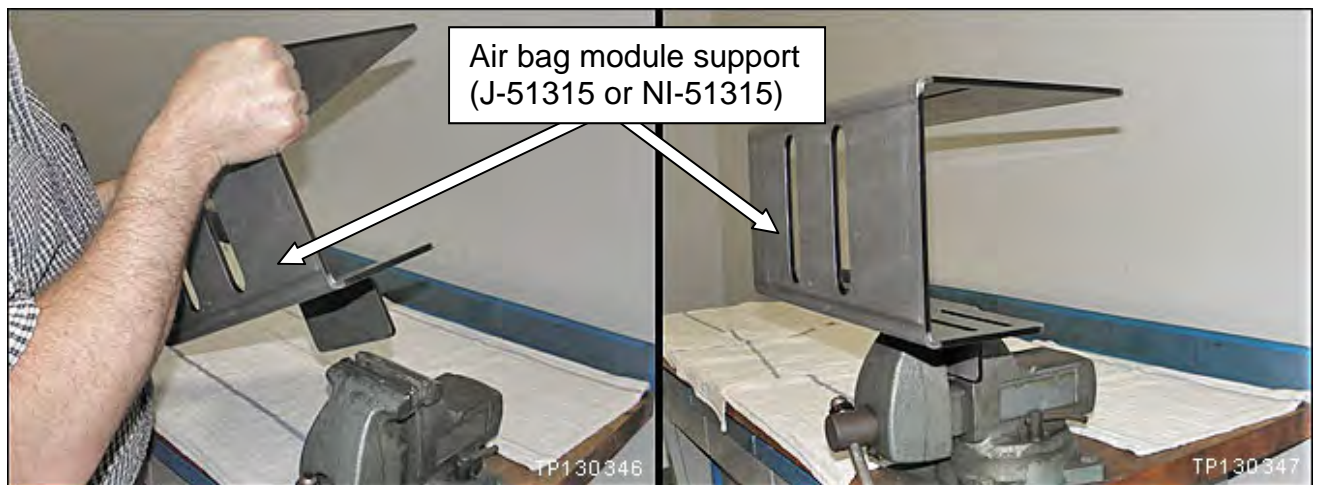

Figure 13

⚠ WARNING

To avoid the risk of death or severe personal injury, work from behind and to the sides of the support, and wear safety glasses while performing inflator replacement.

21. Disconnect the harness clip from the module frame.

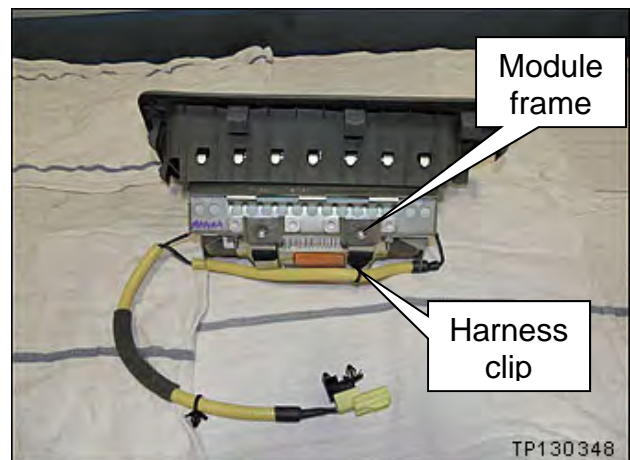

Figure 14

22. Attach the support bracket to the module frame.
- Tighten the bolts holding the bracket to the module frame.
 - Use bolts supplied with the support.
 - Leave the L brackets on each end slightly loose to allow for positioning of the module in the support.

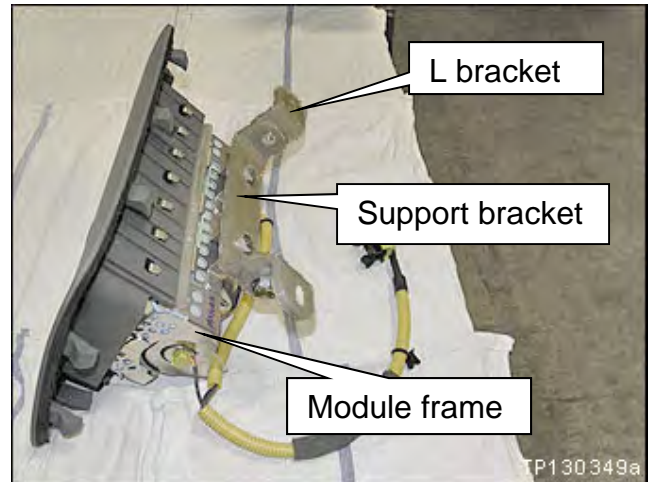

Figure 15

23. Mount the module in the support.
24. Make sure the module is centered in the support.



Figure 16

HINT: Centering the module in the support will allow access to the inflator securing nuts through the slots in the support.

25. Tighten all of the mounting bolts and nuts that hold the module to the support.

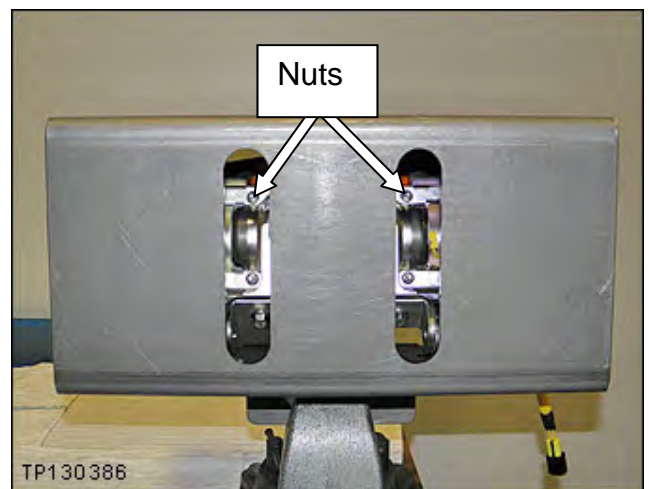

Figure 17

26. Carefully cut a few inches of the yellow corrugated harness cover in the area shown.
- **Do not** cut the wires inside the corrugated cover.



Figure 18

27. Attach two (2) shorting pins to the inflator harness as shown.
- Make sure to pair the wires from each end of the inflator.
- Blue with White**
Red with Yellow
- Use an insulation displacement type wire connector as a shorting pin.
 - Refer to the **PARTS INFORMATION** for additional connector/shorting pin information.

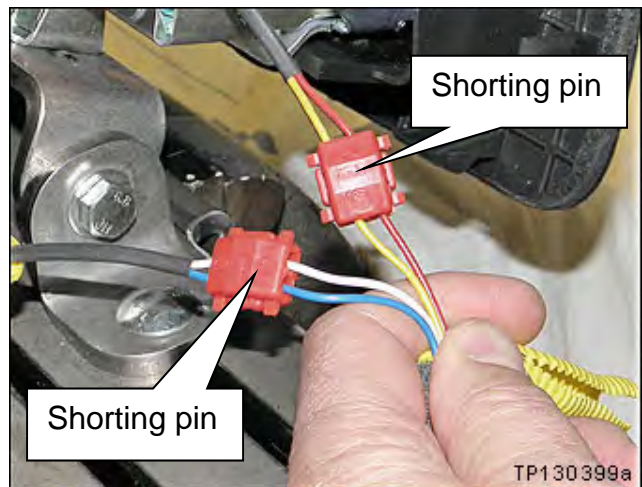

Figure 19

28. Cut off the connector end of the harness.



Figure 20

29. Remove the four (4) nuts from the module that hold the inflator in place (Figure 21 and Figure 22).

- Use a ratchet and extension.



Figure 21

- Remove the four (4) nuts.

HINT: These nuts will not be reused.

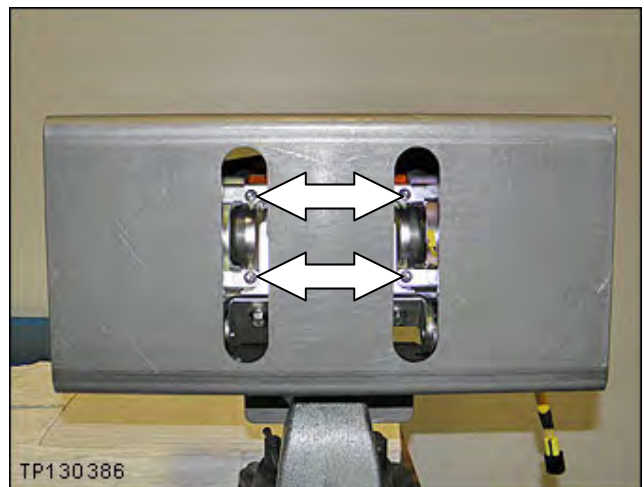

Figure 22

30. Remove the inflator stopper.



Figure 23

31. Push the right side of the inflator out of the module.
- Twist the inflator to a position that will allow the connector and harness to fit through the opening.

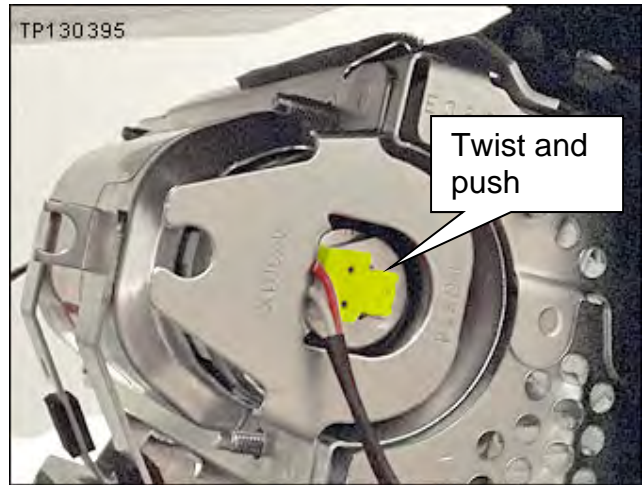

Figure 24

32. Pull the old inflator completely out of the module from the left side.



Figure 25

33. Set the old inflator in the clean working area making sure it does not roll and fall to the floor.

34. Remove the old module from the support and place it on a clean work surface.

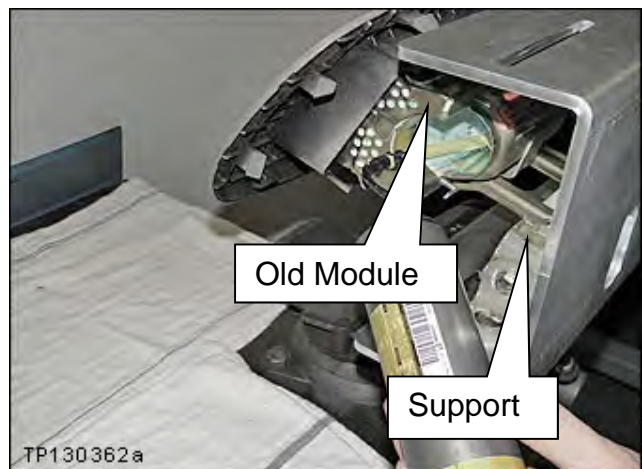

Figure 26

35. Remove the support bracket from the old module.

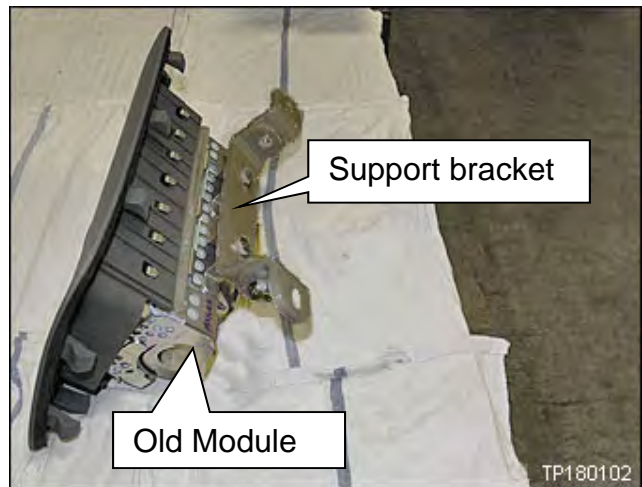

Figure 27

36. Remove the new module from its shipping container.

- New module is listed in the **PARTS INFORMATION**.

37. Remove the instrument panel finisher from the old module, and transfer it to the new module as follows.

- a. Set the module on the bench with the mounting holes facing you.

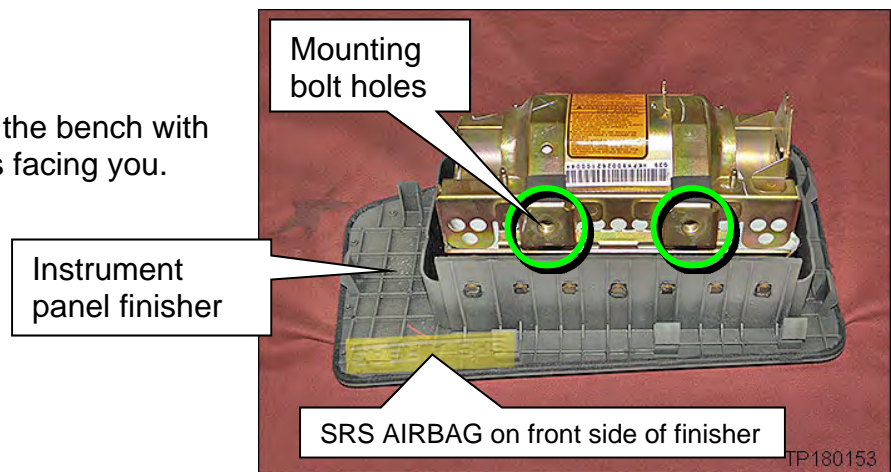

Figure 28

- b. Use a plastic trim tool to detach the module hooks on the side facing you.

- Detach one hook at a time.
- Start at one end and then work towards the opposite end.
- Detach all seven (7) hooks.

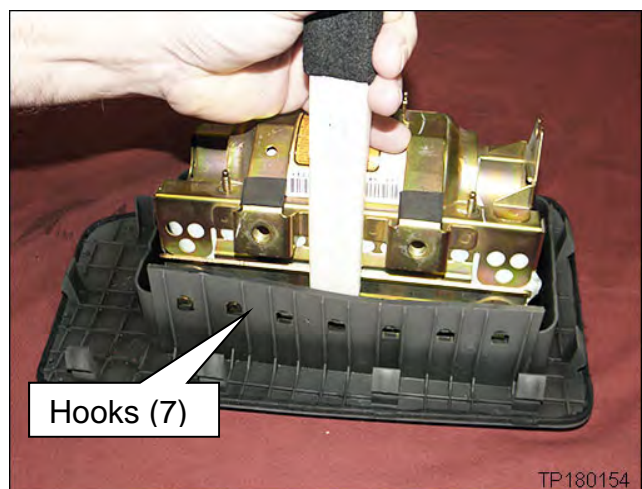

Figure 29

- c. Remove the old module from the finisher.
 - Lift out the side facing you.
 - Use a tilt/twist motion to detach the hooks on the other side.

HINT: The old module will not be reused.

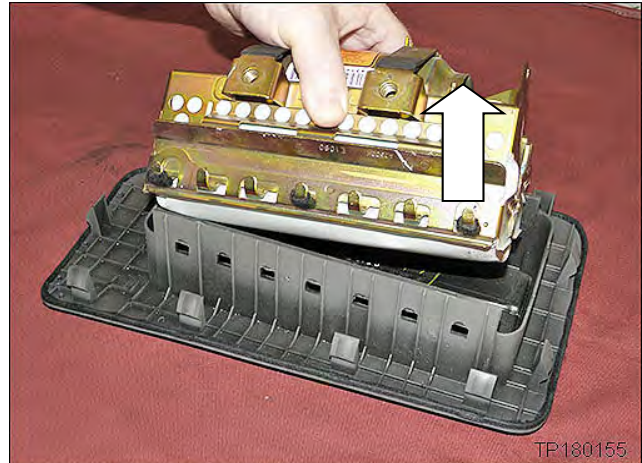

Figure 30

- d. Install the new module to the finisher.
 - Make sure the mounting bolt holes face the side of the finisher with SRS AIRBAG written on it.
 - Make sure all of the hooks are attached correctly.

HINT: SRS AIRBAG is written on the front side of the finisher.

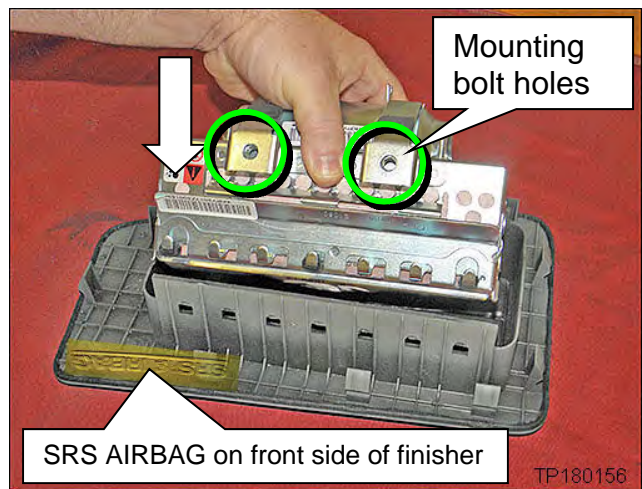

Figure 31

- 38. Attach the support bracket to the new module frame.
 - Use bolts supplied with the support.

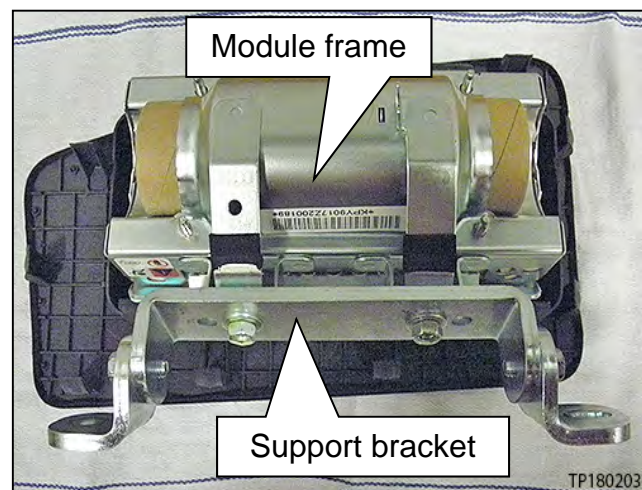

Figure 32

39. Slide the paper tube completely out of the module.

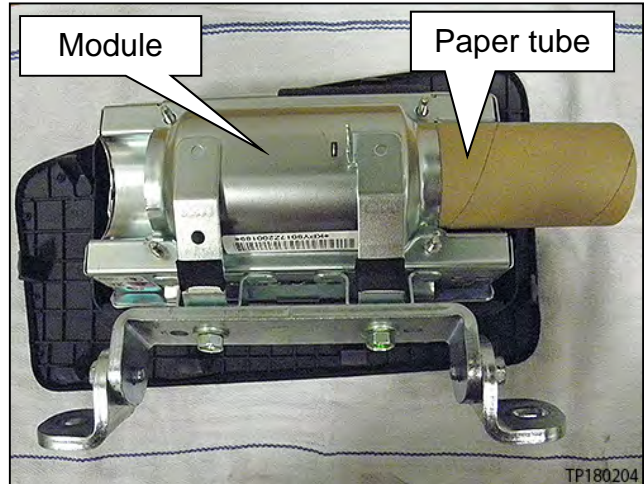

Figure 33

IMPORTANT:

- The new module contains two (2) inflator stopper brackets – one for each side.
- In the following steps, make sure to install the correct stopper bracket on each side of the inflator.

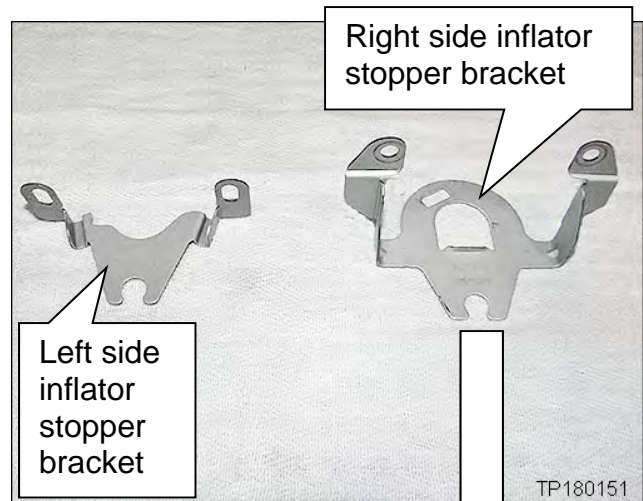

Figure 34

40. Install the right side inflator stopper bracket with nuts finger tight (Figure 35).

- Make sure to use new nuts.

HINT: New nuts and new stopper bracket are included with the new module.

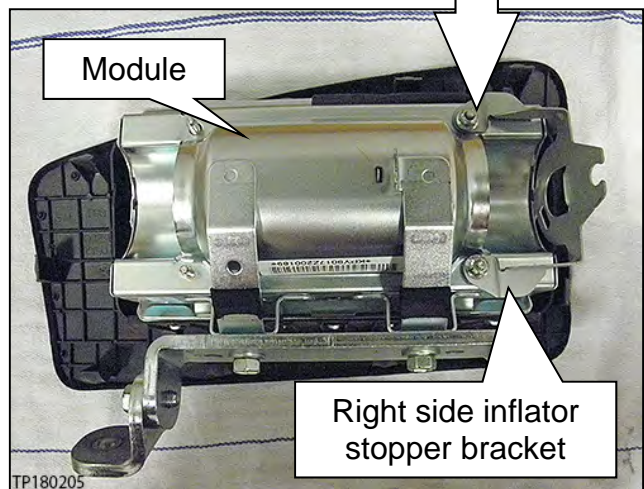

Figure 35

41. Mount the new module in the support.

- Use bolts and nuts supplied with the support.

42. Make sure the module is centered in the support.

HINT: Centering the module in the support will allow access to the inflator securing nuts through the slots in the support.

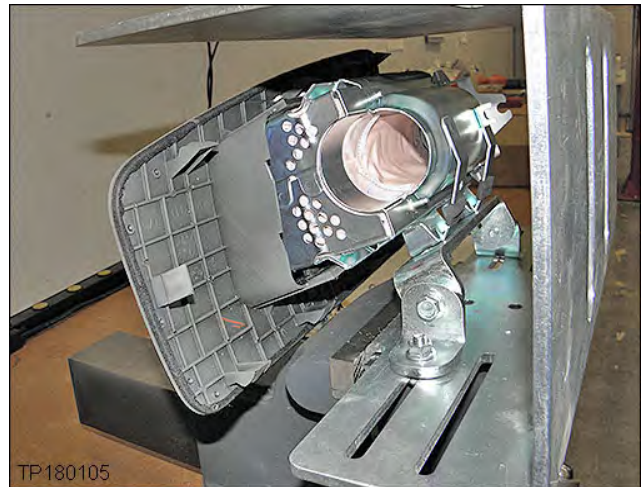

Figure 36

43. Remove the new inflator from the box.

IMPORTANT:

- The new inflator has a large plastic end cap and a small plastic end cap.
- When installing, pay close attention to which end is installed first.

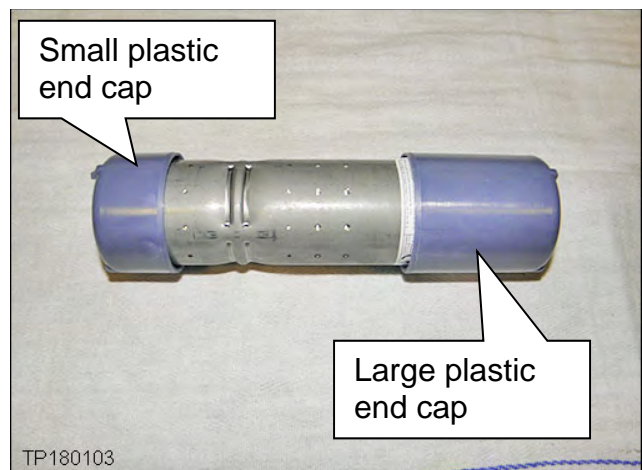

Figure 37

Install the New Inflator into the New Module

44. Slide the new inflator into the module assembly from the left side; large plastic end cap first.

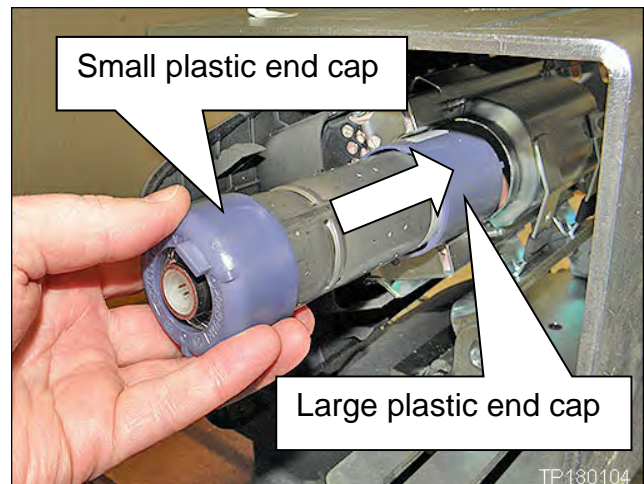

Figure 38

45. On the Right side, make sure the tab on the end of the inflator fits in the stopper bracket as shown.

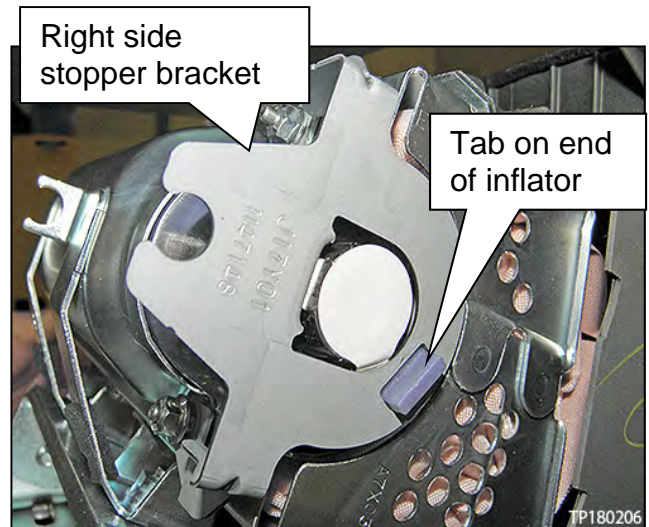

Figure 39

46. Install the left side inflator stopper bracket and two (2) inflator securing nuts finger tight (Figure 40).

- Make sure to use new nuts.

HINT: Stopper bracket and new nuts are included with the new module.

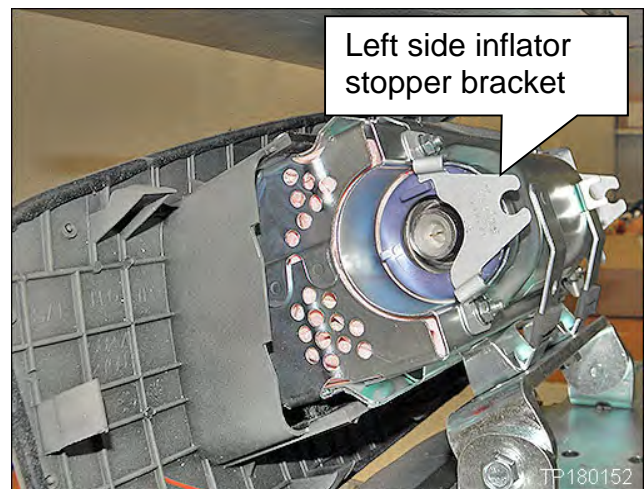

Figure 40

47. Make sure the inflator is pushed all the way into its housing (no gap on the right), and there is no gap between the inflator stopper and the inflator on the left side (Figure 41).

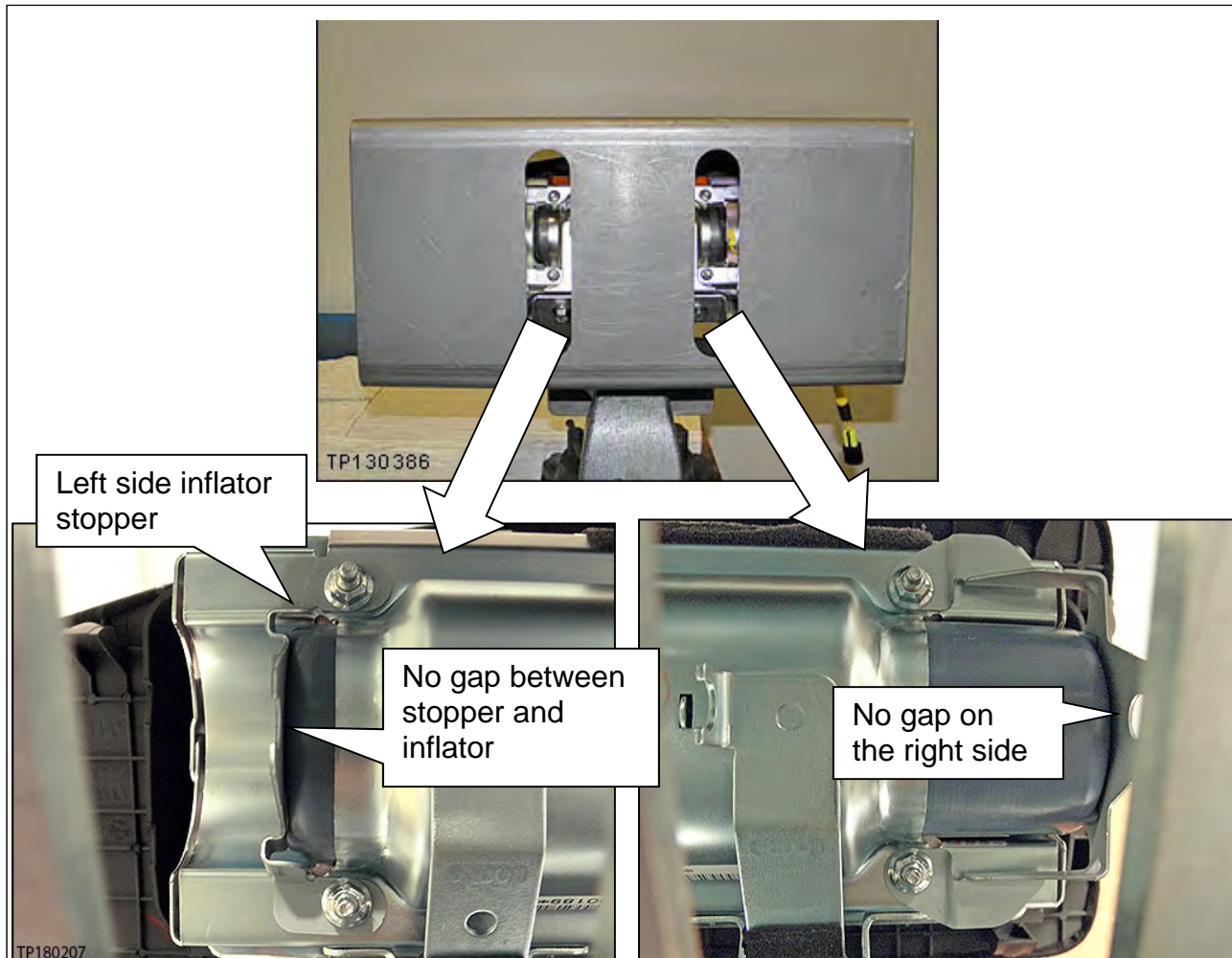

Figure 41

48. Torque the four (4) inflator securing nuts.

- Torque nuts to: 3.9 N•m (0.39 kg-m, **34 in-lb**).
- Torque nuts in the order shown.

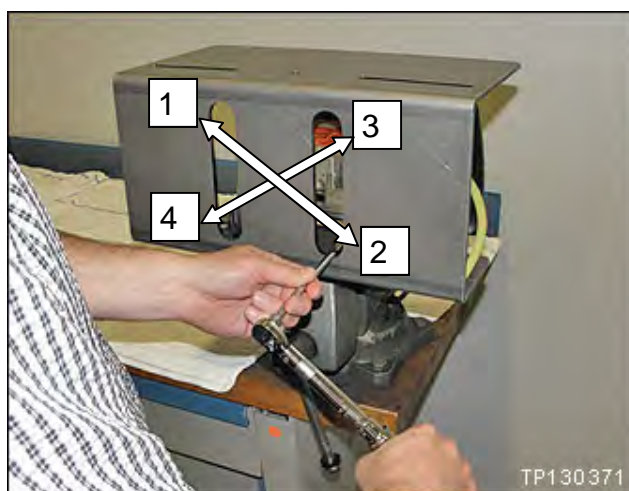

Figure 42

IMPORTANT:

- In the next step you will be attaching the new harness to the new inflator.
- Once an inflator connector is attached to the inflator, it cannot be disconnected.
- **Make sure to attach the connectors to the correct ends of the inflator (Figure 43).**
 - Left / Right orientation is as shown in Figure 43.

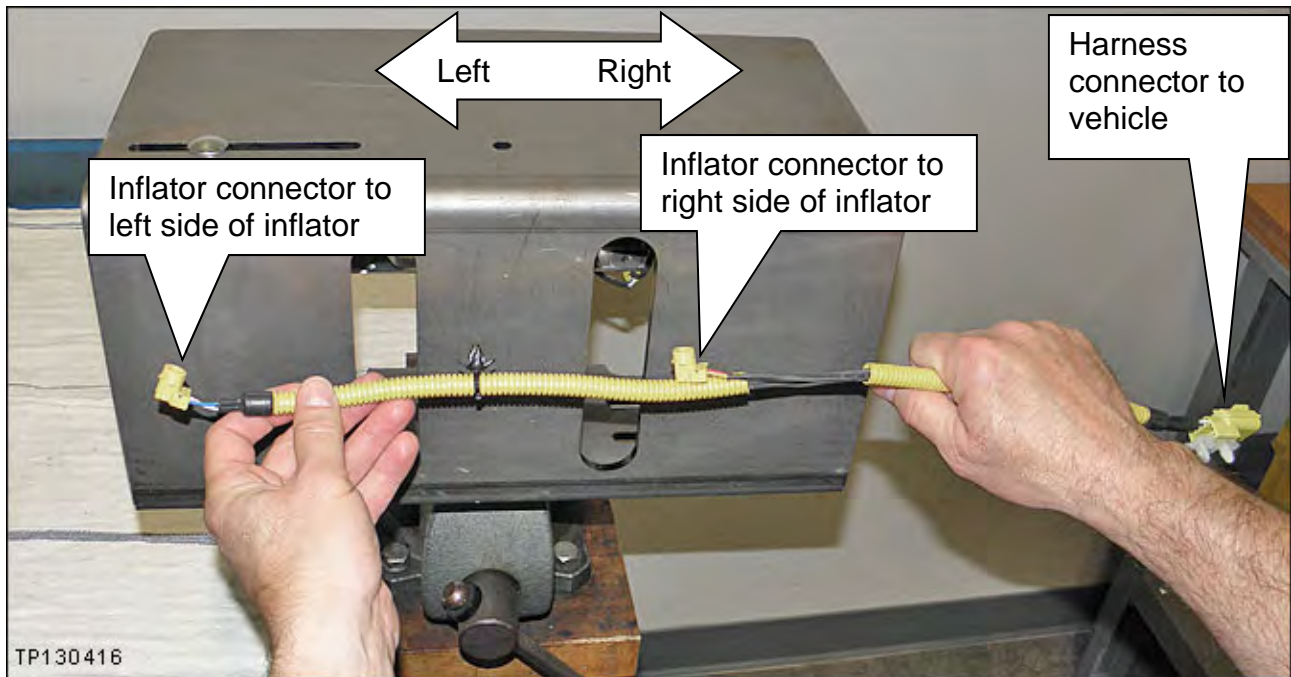

Figure 43

49. Attach the new harness to each end of the inflator.

- Remove the dust proof stickers covering the ends of the inflator.
- A new harness is included with the new module.
- Make sure to attach the correct ends (Figure 43).
- Refer to Figure 44 – Figure 46.



Figure 44

- Make sure the T shape at the inflator end aligns with the T shape of the connector.

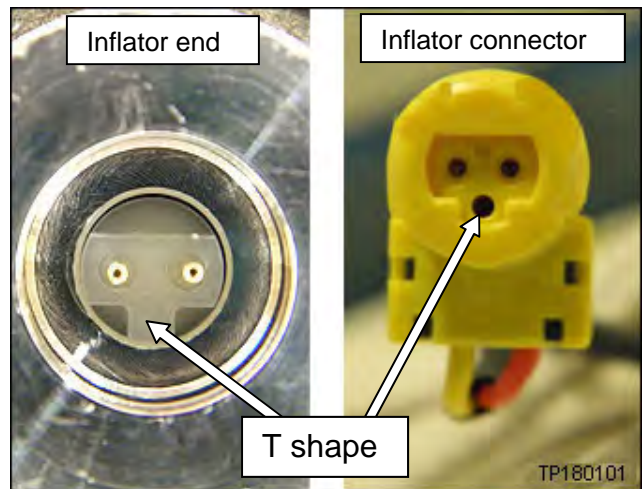

Figure 45

- Make sure the inflator connectors are fully engaged / seated (Figure 46).

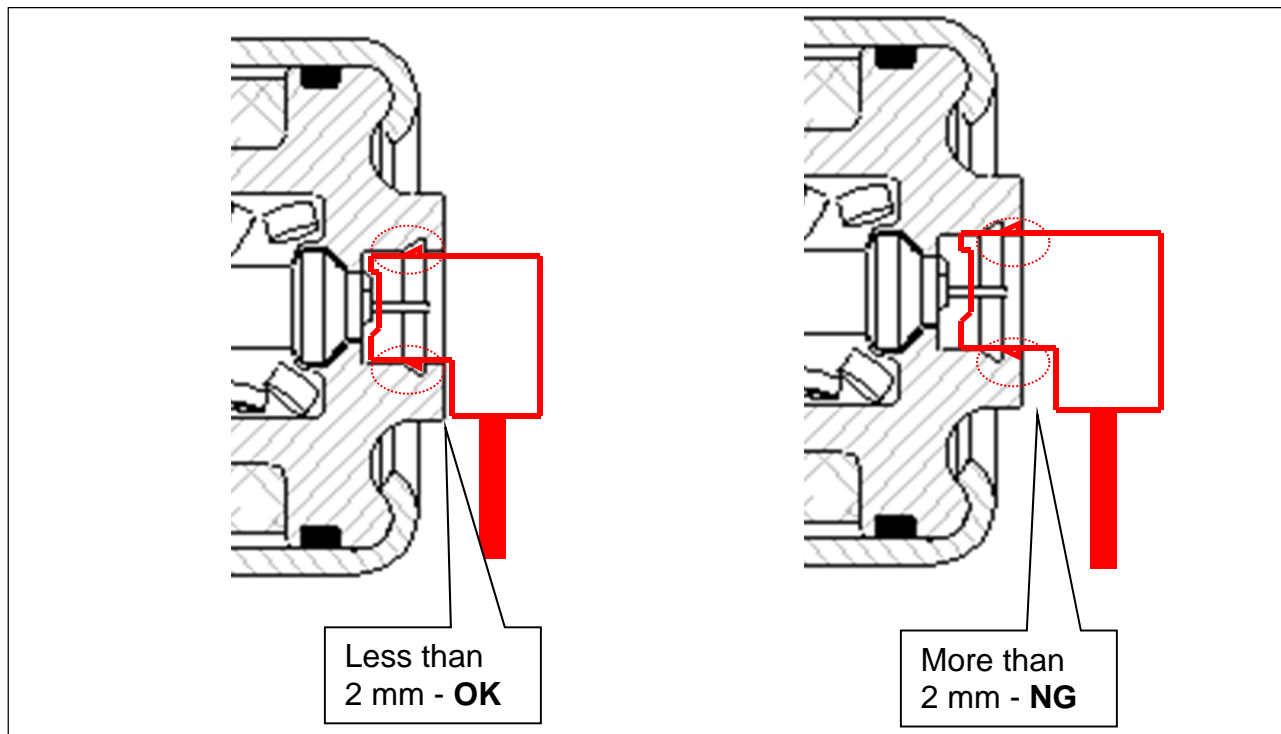

Figure 46

50. Remove the module from the support and set it on the clean working area.

51. Remove the support bracket from the module frame.

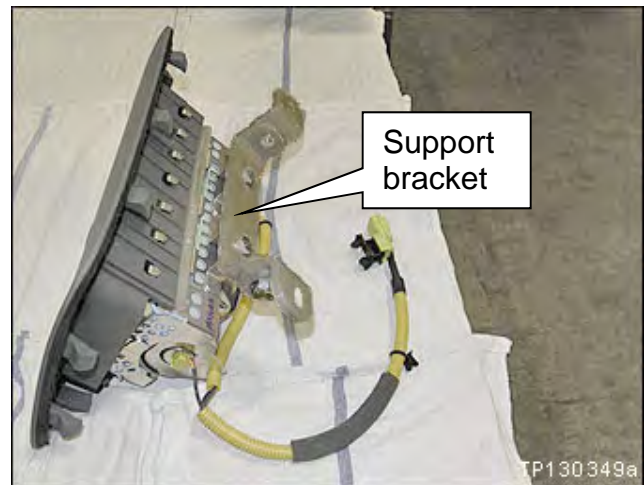

Figure 47

52. Attach the harness clip to the module frame.

53. Route/attach the harness to the harness guides.

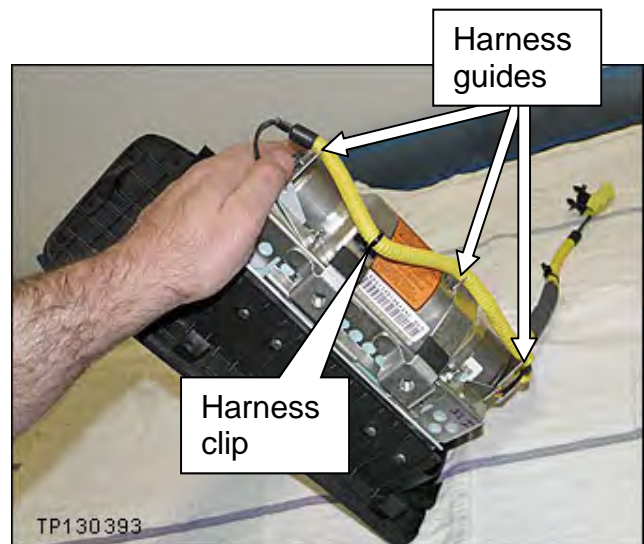

Figure 48

54. Reinstall the module into the vehicle in reverse order of removal.

- Make sure to use the new “one time use” module mounting bolts included with the new module.

55. Re-connect both battery cables, positive cable first.

56. Reset the clock and the radio settings.

57. Turn the ignition ON and observe the air bag warning light:
- Light should illuminate for 7 seconds and then go out.

HINT: If the Air Bag Warning light does not operate as described above there may be an issue not covered by this campaign. Refer to ASIST and the appropriate ESM for additional diagnostic and repair information.

58. **Return the removed (old / non-deployed) inflator in the box that the new inflator arrived in.**
- TK Services and RXO Logistics have provided return instructions for the recalled Takata inflators and modules at pages 27-30 of this bulletin.
 - **Reminder: Federal Hazardous Material Regulations (HMR) govern preparation of shipments of hazardous materials and prohibit handling and preparation for shipment by any person who is not trained and certified as required by the HMR. The HMR impose specific requirements for retailers, packaging, labeling and pre-transportation functions. Violations can result in civil penalties by the Pipeline and Hazardous Materials Safety Administration. (Title 49 Code of Federal Regulations Subchapter C)**

Hazardous Materials Training/Certification Responsibility

In accordance with Title 49, Code of Federal Regulations (49 CFR), Sections 172 Subpart H and 173.1(b), it is the responsibility of the dealer to ensure that every employee handling and preparing hazardous materials for shipment is properly trained/certified. Initial and recurring training can be completed by contacting one of the training companies listed below, or any other company that offers hazardous material training/certification.

SHIPMATE, INC.

Hazardous Materials Training & Consulting 780 Buckaroo Trail, Suite D Sisters, OR 97759
Website: www.shipmate.com Tel: 310.370.3600, Fax: 310.370.5700

DGI Training Center

West Seminar Registrations and On-Site Information 1060 El Camino Real, Suite B
Redwood City, CA 94063-1645 Website: www.dgitraining.com Tel: (650) 306-8450 or
(800) 338-2291

Lion Technology

570 Lafayette Rd. Sparta, NJ 07871-3447 Email: info@lion.com Tel: 888.546.6511,
Fax: 973.579.6818

TAKATA AIRBAG RECALL RETURN INSTRUCTIONS



IMPORTANT: Must be performed by certified DOT HAZMAT personnel.

<p>Takata Airbag Recall</p>	<h2>Inflator and Module Returns Shipping Instructions</h2> <p>Please contact scfieldaction.14305@rxo.com for documentation and to arrange pickup If retailers do not receive a response from an RXO logistics specialists within 48 to 72 hours, then they can utilize the escalation number, (210) 317-6436 for further assistance.</p>	<p>06/20/2023</p>
-------------------------------------	---	-------------------

1. Shipping Documents

- Pallet Label**
 - To be emailed by RXO
 - To be affixed to each Pallet
- Over-pack Label**
 - To be emailed by RXO
 - To be affixed to the outside of each pallet
- Bill of Lading**
 - To be emailed by RXO.
 - Print 2 copies: 1 for Dealer Records, 1 for Driver.
- ERG Document**
 - To be emailed by RXO.
 - To be provided by the Dealer to the Driver for each shipment



TK SERVICES
1199 AUSTIN COURT
HOWELL, MI 48843

5. Shipping Instructions – Prepare the Pallet

- Accumulate and palletize Kits
- Arrange Kits on Pallet as pictured here
 - 20 boxes per row/layer (5x4)
 - 10 rows/layers per pallet (200 boxes)
- Shrink-wrap Kits to Pallet
- Affix Over-pack Label and Pallet Label on (1) side of Pallet (Not on Top)
- If 200 boxes are not accumulated every 2 weeks, please proceed to step 6.

Note: If you receive non-uniform sized kits (Older version), Please contact RXO via the instructions in Box 6 for additional Instructions





TK SERVICES
1199 AUSTIN COURT
HOWELL, MI 48843

2. Packing Instructions



****DO NOT DEPLOY THE INFLATOR****

- Confirm box is in acceptable condition. Box should be in good condition with no visible signs of damage and should be capable of withstanding additional transportation.
- If a new box is needed, follow the New Box instructions located in section #8 of this page.
- Place the un-deployed air bag inflator or module in the "cradle" of the box insert.

3. Closure Instructions

- Close the top box flap, per box closure instructions located on front panel of box using a 2" wide by 4" long piece of tape to securely close the box.

6. Shipping Instructions – Schedule Pickup

- Upon Accumulating 200 kits (1 Over-pack/Pallet) Minimum
 - Contact RXO at the e-mail noted above. If 200 Kits have not been accumulated every 2 weeks, please contact RXO for direction.
 - Complete shipping template and attach to E-Mail.
- Have the following Information Available
 - Dealer #
 - Quantity of Over-packs/Pallets
 - Quantity of Driver Kits and Quantity of Passenger Kits on each Pallet
 - Email Address where shipping Documentation can be received
 - Lift gate Service Needed?

7. Shipping Instructions – Ship

- Give 1 Copy of BOL and 1 Copy of ERG to Driver
- Retain 1 Copy of BOL for Dealership records and archive for at least 2 Years

4. Shipping Instructions - Label each Box

- OEM module/inflator kit contains this 2-part label
- Peel off 'Ship-To' label
- Affix label to box. Do not cover up Class 9 Marking



8. Requesting a New Box / Shipping Labels

If a new box or replacement box shipping labels are needed, please contact a representative by email to request replacement materials.

Primary Contact:
E-Mail: scfieldaction.14305@rxo.com

To help expedite your request, please be prepared to provide the following information:

- Serial number on the original box (if replacement box is needed)
- What Type of shipping material needed
 - Replacement Box
 - Two Part Return Label
 - Bill of Lading
 - ERG Form
- Dealer Shipping Information
 - Contact Name
 - Dealer Address
 - Phone Number

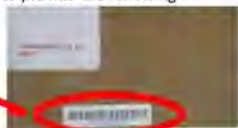

NOTE: International and ALL Locations outside of the Continental United States (APAC, EMEA, Mexico, Hawaii, Alaska, Puerto Rico, and US Virgin Islands dealers) CANNOT follow above shipping instructions. Instead, dealerships in these locations MUST contact TK services /RXO USA representative directly for shipping instructions: RXO Representative .Email: scfieldaction.14305@rxo.com Continental US 48 State Dealerships, please follow steps 1-8 above.

BOOKING TEMPLATE FOR TAKATA AIRBAG RECALL RETURNS

PALLET (S) MUST BE READY BEFORE SENDING IN THE TEMPLATE. ALL FIELDS PERTAINING TO YOUR LOAD MUST BE FILLED IN AND SENT TO SCFIELDACTION.14305@RXO.COM. ESCALATION PHONE NUMBER : 210-317-6436. TEMPLATE MUST BE USED FOR ALL BOOKING REQUESTS.

Dealer Code					
Dealer Name					
Pickup Address					
City, State & Zip					
YOUR Name & Phone#(DO NOT GIVE YOUR CELL #)					
Hours available for pickup					
Email Address for BOL					
Do you need a truck with lift gate and pallet jack (YES or NO)					
SPECIAL EQPT NEEDS OR SPECIFIC CARRIER REQUEST					
	Pallet #1	Pallet #2	Pallet #3	Pallet #4	Pallet #5
Driver Side Count					
Passenger Side Count					
TOTAL	0	0	0	0	0

	Pallet #6	Pallet #7	Pallet #8	Pallet #9	Pallet #10
Driver Side Count					
Passenger Side Count					
TOTAL	0	0	0	0	0

	Pallet #11	Pallet #12	Pallet #13	total boxes
Driver Side Count				0
Passenger Side Count				0
TOTAL	0	0	0	0

TRUCK LOAD IS 14 + PALLETS	USE THIS SECTION FOR 14 PALLETS OR MORE
TOTAL PALLET COUNT	
TOTAL DRIVER COUNT	
TOTAL PASSENGER COUNT	
TOTAL WEIGHT	

PALLET (S) MUST BE READY BEFORE SENDING IN THE TEMPLATE. ALL FIELDS PERTAINING TO YOUR LOAD MUST BE FILLED IN AND SENT TO SCFIELDACTION.14305@RXO.COM ESCALATION PHONE NUMBER 210-317-6436 MIGUEL PRIGAADA

Dealer Code Dealer or Business Name

Pickup Address City, State & Zip

Physical Address (if different from pickup address) City, State & Zip

YOUR Name & Phone # Hours Available for Pickup

Days/hours pickup is not allowed (lunch hour if shut down)

Email address for BOL Do you need a truck with lift gate and pallet jack? YES NO

Where can the driver expect to find pallet on property? Please give clear directions

Special instructions or notes that will help driver locate pallet on site

	Pallet #1	Pallet #2	Pallet #3	Pallet #4	Pallet #5	Pallet #6	Pallet #7	Pallet #8	Pallet #9	Pallet #10	Pallet #11	Pallet #12	Pallet #13	Pallet #14	Total Boxes
Driver Side Count	<input type="text"/>	<input type="text"/>	<input type="text"/>	<input type="text"/>	<input type="text"/>	<input type="text"/>	<input type="text"/>	<input type="text"/>	<input type="text"/>	<input type="text"/>	<input type="text"/>	<input type="text"/>	<input type="text"/>	<input type="text"/>	<input type="text"/>
Passenger Side Count	<input type="text"/>	<input type="text"/>	<input type="text"/>	<input type="text"/>	<input type="text"/>	<input type="text"/>	<input type="text"/>	<input type="text"/>	<input type="text"/>	<input type="text"/>	<input type="text"/>	<input type="text"/>	<input type="text"/>	<input type="text"/>	<input type="text"/>
Total	0	0	0	0	0	0	0	0	0	0	0	0	0	0	0

PARTS INFORMATION

DESCRIPTION	PART #	QUANTITY
INFLATOR-AIR BAG (Inflator)	98561-7999E	1
MODULE KIT-SUB (Includes module mounting bolts, inflator harness, inflator securing nuts, and stopper brackets)	K8525-4Y90C	1
<p style="text-align: center;">Shorting Pin (Insulation Displacement Connector for 22-18 gauge wire)</p> 	<p style="text-align: center;">NAPA item # 784566</p> <p style="text-align: center;">Grainger Item # 4YT50</p> <p style="text-align: center;">or equivalent available from local auto supply</p>	2

HINT:

- Make sure to return the removed (old / non-deployed) inflator in the box that the new inflator came in.
- Follow the **RETURN INSTRUCTIONS** beginning on page 27.

CLAIMS INFORMATION

Submit a "CM" line claim using the following claims coding:

CAMPAIGN ("CM") ID	DESCRIPTION	OP CODE	FRT
PC906	Remove and replace front passenger air bag module assembly	PC9060	1.0

EXPENSE CODE

EXPENSE CODE	DESCRIPTION	MAX AMOUNT
041	Shorting Pin (Insulation Displacement Connector for 22-18 gauge wire)	\$1.00

AMENDMENT HISTORY

PUBLISHED DATE	REFERENCE	DESCRIPTION
August 15, 2022	NTB22-070	Original bulletin published
July 27, 2023	NTB22-070A	Updated REQUIRED SPECIAL TOOLS on page 3, revised pages 1, 5, 6, 7 and 26, added pages 27-30, NOTE references changed to HINT