

Important Safety Recall

Airstream Touring Coach and Travel Trailer
NHTSA 22V-595/Transport Canada 2022-544

Operation code: (Touring Coach) TCSBR8905100 & (Travel Trailer) TTSTR8905100

Labor rate will be: 1 hr.

It has come to our attention that in certain model year 2021 & 2022 Atlas & Interstate (19" & 24') touring coaches, and certain model year 2021 & 2022 Bambi & Basecamp travel trailers, the Dometic 2 burner cooktop control valve that is mated directly to the control knob via the valve stem on the cooktop, may leak gas. The burner control valve may have incurred abrasions, internally or externally, on the mating metal sealing surfaces of the burner control valve that may have led to leaks.

NOTE: At the time these vehicles were being manufactured Airstream was using two different vendors due to supply chain shortages. Because of this, if a unit has a Suburban 2 burner cooktop, it IS NOT affected by this recall. If a unit has a Dometic 2 burner cooktop and was manufactured within the serial number range and date range noted below, you will need to contact Dometic and provide them with the model and serial number from the cooktop in order to request the replacement cooktop. The replacement cooktop will be provided at no cost. Upon receiving the cooktop, the remedy instructions will be provided as well as a recall response card that must be filled out and sent back to Dometic as stated in their instructions.

Please contact the Airstream Customer Service office at 877-344-1076 ext. 7491 for travel trailer or ext. 7401 for touring coach. You may also email us at customersupport@airstream.com for further assistance.

RANGE OF VEHICLES INVOLVED:

Airstream built between March 22, 2021 - December 29, 2021

Serial number range: (Touring Coach) 306791-309425, (Bambi) 557099-560983, (Basecamp) 205412-206706

Note: Because our VINs do not run in a contiguous series, there will be units in the VIN range which will not be affected by this Service Bulletin.

Equipment needed:

A Dometic cooktop if needed.



Tools needed:

13/16 wrench
11/16 wrench



#10 torque bit
screwdriver



Leak solution



Manometer



If the unit fall inside the vin number range and has the Dometic cooktop it will need to be changed

If the unit has the Suburban cooktop then no other steps need to be taken. This cooktop passes.



To remove the Dometic cooktop:

Turn off the LP system before removing the cooktop.

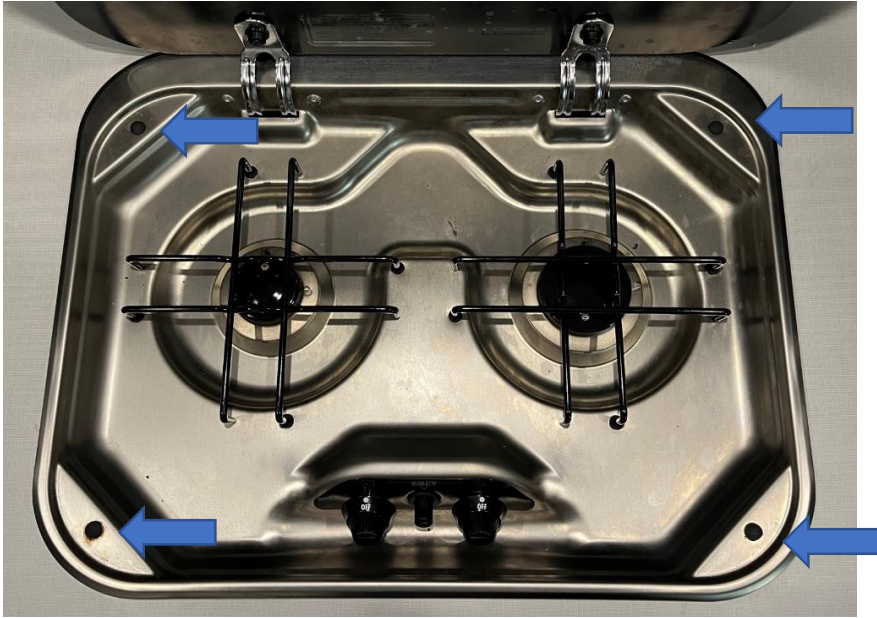

Using a small screwdriver remove the rubber plug cap from the screw hole



Use a #10 torque bit to loosen all four screws to loosen the clamps.

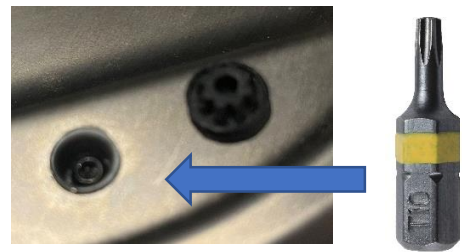

Pictured below is the bottom side of the clamp.

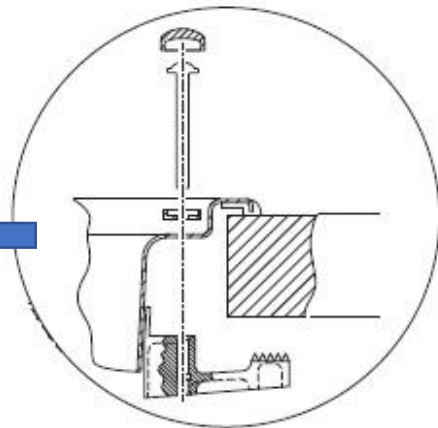
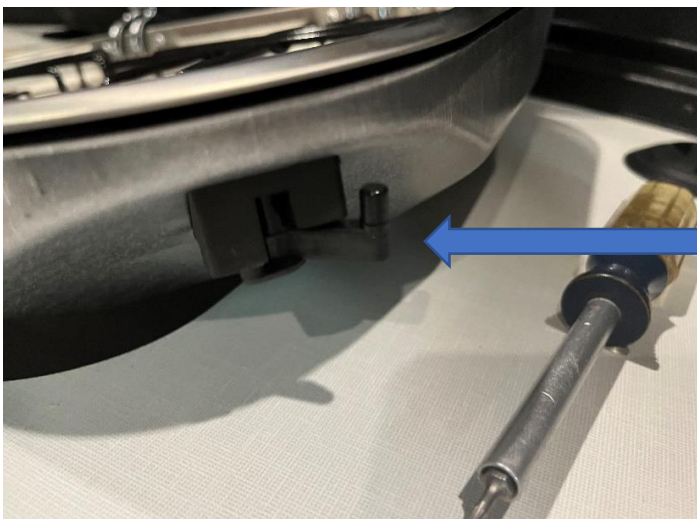

Use a 13/16 and a 11/16 wrench to remove the gas line.

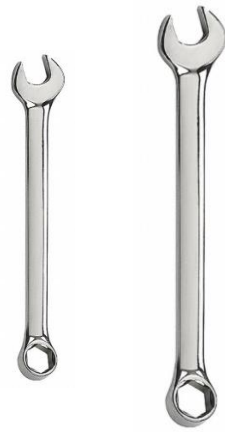
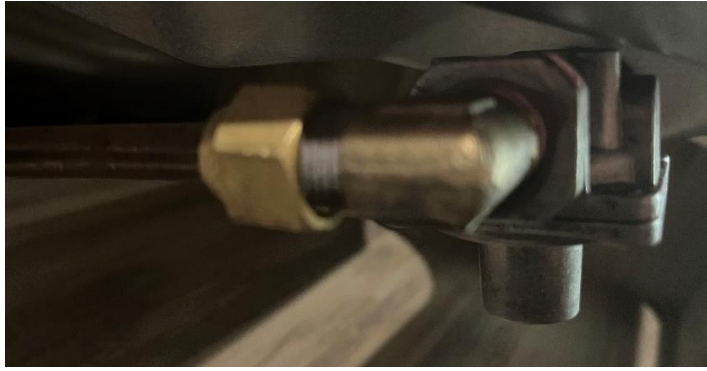

Install the new cooktop:

Connect the LP line first. Check for leak before tightening the clamp.

Use gas leak solution on the connection and also do a LP drop pressure test.



After The cooktop passes the leak test tighten the four clamp and replace the rubber plugs.

