



Stacy L. Balzer
Operating Director
Service Engineering Operations
Ford Customer Service Division

Ford Motor Company
P. O. Box 1904
Dearborn, Michigan 48121

January 25, 2023

TO: All U.S. Ford and Lincoln Dealers

SUBJECT: **NEW VEHICLE DEMONSTRATION / DELIVERY HOLD**
Compliance Recall 22C20 - Supplement #1
Certain 2022 Model Year Maverick
Side Airbag Curtain Replacement

REF: **NEW VEHICLE DEMONSTRATION / DELIVERY HOLD**
Compliance Recall 22C20
Dated November 9, 2022

New! REASON FOR THIS SUPPLEMENT

- **Technical Instructions:** *Repair procedure updated for clarity.*
- **Parts Requirements/Ordering Information:** *The seed stock program has been lifted. Parts ordering through SSSC is still required.*

AFFECTED VEHICLES

Vehicle	Model Year	Assembly Plant	Build Dates
Maverick	2022	Hermosillo Plant	February 3, 2021, through July 9, 2022

Affected vehicles are identified in OASIS and FSA VIN Lists.

Note: Some vehicles may be in the process of being repaired at the plant. Monitor OASIS before opening an RO and/or beginning a repair. Parts purchased for an FSA can be returned for credit, if required. See the EXCESS STOCK RETURN details in Attachment II for more information.

REASON FOR THIS COMPLIANCE RECALL

All the affected vehicles may not conform to the requirements specified by Federal Motor Vehicle Safety Standard (FMVSS) No. 226 Ejection Mitigation for front-row passengers, a vehicle that does not comply with FMVSS 226 increases the risk of injury in a crash.

SERVICE ACTION

Before demonstrating or delivering any new in-stock vehicles involved in this recall, dealers are to replace both side airbag curtains. This service must be performed on all affected vehicles at no charge to the vehicle owner.

OWNER NOTIFICATION MAILING SCHEDULE

Remedy owner letters are expected to be mailed mid-1st quarter of 2023.

PLEASE NOTE:

Federal law requires dealers to complete this recall service before a new vehicle is delivered to the buyer or lessee. Violation of this requirement by a dealer could result in a civil penalty of up to \$26,315 per vehicle. Correct all vehicles in your new vehicle inventory before delivery.

ATTACHMENTS

Attachment I: Administrative Information

Attachment II: Labor Allowances and *Parts Ordering Information*

Attachment III: *Technical Information*

Recall Reimbursement Plan

QUESTIONS & ASSISTANCE

For questions and assistance, contact the Special Service Support Center (SSSC) via the SSSC Web Contact Site. The SSSC Web Contact Site can be accessed through the Professional Technician System (PTS) website using the SSSC link listed at the bottom of the OASIS VIN report screen or listed under the SSSC tab.

Sincerely,



Stacy L. Balzer

NEW VEHICLE DEMONSTRATION / DELIVERY HOLD
Compliance Recall 22C20 - Supplement #1
Certain 2022 Model Year Maverick
Side Airbag Curtain Replacement

OASIS ACTIVATION

OASIS was activated on September 22, 2022

FSA VIN LISTS ACTIVATION

FSA VIN Lists were made available through <https://web.fsavinlists.dealerconnection.com> by September 22, 2022. Owner names and addresses will be available mid-1st quarter of 2023.

NOTE: Your FSA VIN Lists may contain owner names and addresses obtained from motor vehicle registration records. The use of such motor vehicle registration data for any purpose other than in connection with this recall is a violation of law in several states, provinces, and countries. Accordingly, you must limit the use of this listing to the follow-up necessary to complete this recall.

SOLD VEHICLES

- Ford has not issued instructions to stop driving used vehicles under this compliance recall.

STOCK VEHICLES

- Correct only affected units with sales contracts at this time in new vehicle inventory before delivery. Dealers will be notified when enough parts are in inventory to repair all affected units
- Use OASIS to identify any affected vehicles in your used vehicle inventory.

DEALER-OPERATED RENTAL VEHICLES

The Fixing America's Surface Transportation (FAST) Act law effective June 2016 prohibits a rental company from selling, renting, or leasing vehicles subject to a safety or compliance recall. Please consult your legal counsel for legal advice.

TITLE BRANDED / SALVAGED VEHICLES

Affected title-branded and salvaged vehicles are eligible for this recall.

OWNER REFUNDS

- **This safety recall must still be performed, even if the owner has paid for a previous repair. Claiming a refund will not close the recall on the vehicle.**
- Ford Motor Company is offering a refund for owner-paid repairs covered by this recall if the repair was performed before the date indicated in the reimbursement plan, which is posted with this bulletin. Owners are directed to seek reimbursement through authorized dealers or, at their option, directly through Ford Motor Company at P.O. Box 6251, Dearborn, MI 48121-6251.
- Dealers are also pre-approved to refund owner-paid emergency repairs that were performed away from an authorized servicing dealer after the end date specified in the reimbursement plan. Non-covered repairs, or those judged by Ford to be excessive, will not be reimbursed.
- Refunds will only be provided for the cost associated with the side airbag replacement.

RENTAL VEHICLES

Rental vehicles are not approved for this program.

NEW VEHICLE DEMONSTRATION / DELIVERY HOLD
Compliance Recall 22C20 - Supplement #1
Certain 2022 Model Year Maverick
Side Airbag Curtain Replacement

ADDITIONAL REPAIR (LABOR TIME AND/OR PARTS)

Additional repairs identified as necessary to complete the FSA should be managed as follows:

- For related damage and access time requirements, refer to the Warranty and Policy Manual / Section 6 – Ford & Lincoln Program Policies / General Information & Special Circumstances for FSA's / Related Damage.
- For vehicles within new vehicle bumper-to-bumper warranty coverage, no SSSC approval is required, although related damage must be on a separate repair line with the "Related Damage" radio button checked.
 - Ford vehicles – 3 years or 36,000 miles
- For vehicles outside new vehicle bumper-to-bumper warranty coverage, submit an Approval Request to the SSSC Web Contact Site before completing the repair.

CLAIMS PREPARATION AND SUBMISSION

- **Claim Entry:** Enter claims using Dealer Management System (DMS) or One Warranty Solution (OWS) online.
 - When entering claims, select claim type 31: Field Service Action. The FSA number 22C20 is the subcode.
 - For additional claims preparation and submission information, refer to the Recall and Customer Satisfaction Program (CSP) Repairs in the OWS User Guide.
- **Related Damage/Additional labor and/or parts:** Must be claimed as Related Damage on a separate repair line from the FSA with the same claim type and subcode as described in Claim Entry above.
IMPORTANT: Click the Related Damage Indicator radio button.
- **Refunds:** Submit refunds on a separate repair line.
 - Program Code: 22C20 - Misc. Expense: ADMIN
 - Misc. Expense: REFUND - Misc. Expense: 0.2 Hrs.
 - Multiple refunds should be submitted on one repair line and the invoice details for each repair should be detailed in the comments section of the claim.

NEW VEHICLE DEMONSTRATION / DELIVERY HOLD
Compliance Recall 22C20 - Supplement #1
Certain 2022 Model Year Maverick
Side Airbag Curtain Replacement

LABOR ALLOWANCES

Description	Labor Operation	Labor Time
Replace both side airbag curtains	22C20B	2.0 Hours

New! Special Program Part Ordering

To place an order for side airbag curtains, submit an open R.O. number and VIN-specific Part Order contact via the SSSC Web Contact Site.

Part Number	Description	Order Quantity	Claim Quantity
NZ6Z-26042D94-B	Curtain Assembly - RH	1	1
NZ6Z-26042D95-B	Curtain Assembly - LH	1	1
W710947-S450	Bolt (4 in package)	1	2

Dealers will be notified via a DOES II communication if circumstances warrant a change in part supply strategy and when open ordering resumes.

DEALER PRICE

For the latest prices, refer to DOES II.

PARTS RETENTION, RETURN, & SCRAPPING

Follow the provisions of the Warranty and Policy Manual, Section 1 - WARRANTY PARTS RETENTION AND RETURN POLICIES. If a replaced part receives a scrap disposition, the part must be scrapped by all applicable local, state, and federal environmental protection and hazardous material regulations. Federal law prohibits selling motor vehicle parts or components that are under safety, compliance, or emissions recall.

EXCESS STOCK RETURN

The excess stock returned for credit must have been purchased from Ford Customer Service Division by Policy Procedure Bulletin 4000.

NEW VEHICLE DEMONSTRATION / DELIVERY HOLD
Compliance Recall 22C20 - *Supplement #1*
Certain 2022 Model Year Maverick
Side Airbag Curtain Replacement

REPLACED FSA PARTS INSPECTION AND SIGN OFF

Effective March 1st, 2021 all parts replaced as part of an FSA repair with a repair order open date of March 1st, 2021, or later must be inspected and signed off on the repair order by a member of your dealer fixed operations management team or an employee of the task has been delegated to. If the task is to be delegated to a non-management employee, the employee needs to be someone other than the technician who completed the repair and needs to understand the importance of completing this task consistently and accurately.

- All parts replaced as part of an FSA repair should be returned to the parts department following the Warranty Parts Retention and Return Policies.
- Inspect the replaced parts to verify the FSA repair was completed.
- If the FSA repair is found to be complete, the designated employee signs the repair order line or parts return stamp area (electronic or hand signed) for the FSA repair indicating the parts were inspected and validated to have been replaced.
- After the parts have been inspected, they should be handled based on the guidance in the parts status report in the Online Warranty System (Hold, Return, CORE, Scrap, etc.).
- This process is subject to review during warranty audits for FSA repairs with a repair order open date of March 1st, 2021, or later. Any eligible FSA claims requiring parts replacement found not to have been inspected and signed off during a warranty audit will be subject to chargeback and consideration for enrollment into the Dealer Incomplete Recall Repair Process.

Note: Other approvals (electronic or handwritten) for add-on repair lines, dealer-owned vehicle repairs, and repeat repairs do not qualify as FSA parts inspection approvals. The post-repair FSA parts inspection process (electronic or handwritten) is independent of other warranty approval requirements. The approval by the designated employee implies that the FSA parts were found to be replaced and must be able to be identified on the Repair Order. If multiple FSAs require approval on a single Repair Order, each applicable occurrence will require individual post-repair approval by the designated employee.

CERTAIN 2022 MODEL YEAR MAVERICK VEHICLES — DRIVER AND PASSENGER SIDE CURTAIN AIRBAG REPLACEMENT

NEW ! SERVICE PROCEDURE

1. On both sides remove the A-pillar trim panels. Please follow the Workshop Manual (WSM) procedures in Section 501-05.
2. On both sides remove the B-pillar lower trim panels. Please follow the WSM procedures in Section 501-05.
3. Depower Supplemental restraint System (SRS). Please follow the WSM procedures in Section 501-20B.
4. Position the front seatbelt anchor and pretensioner aside, disconnect the front seatbelt anchor and pretensioner electrical connector and remove the front seatbelt anchor and pretensioner bolt. See Figure 1.

- Torque: 40 Nm (30 lb.ft).

NOTE: Left Hand (LH) side shown, Right Hand (RH) side similar.

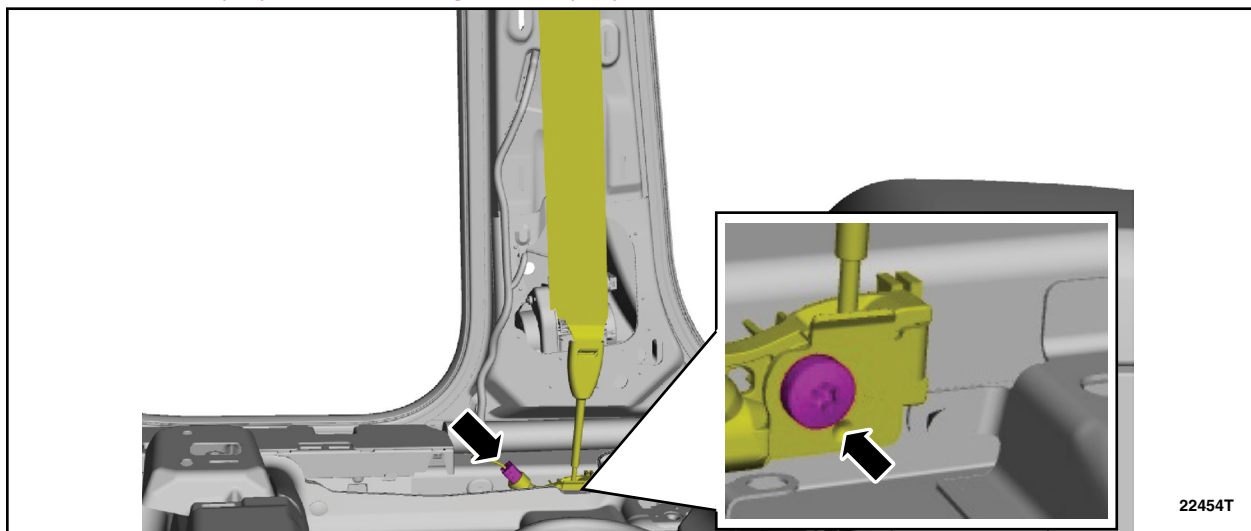

FIGURE 1



5. On both sides remove the B-pillar upper trim panel bolt. See Figure 2.

- Torque: 9 Nm (80 lb.in).

NOTE: LH side shown, RH side similar.

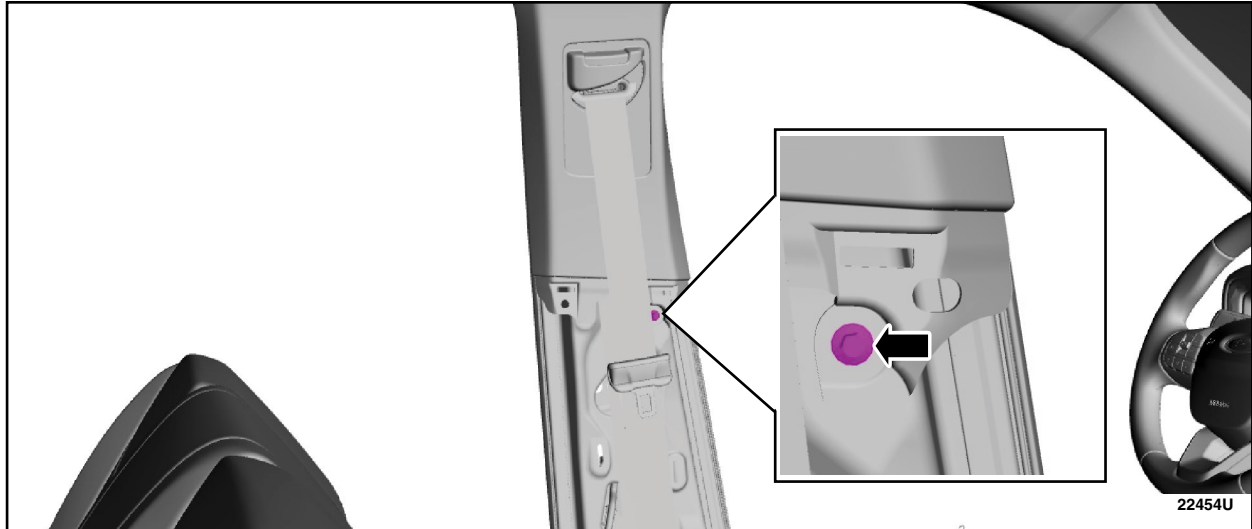

FIGURE 2

6. On both sides release the B-pillar upper trim panel lower clip. See Figure 3.

NOTE: LH side shown, RH side similar.

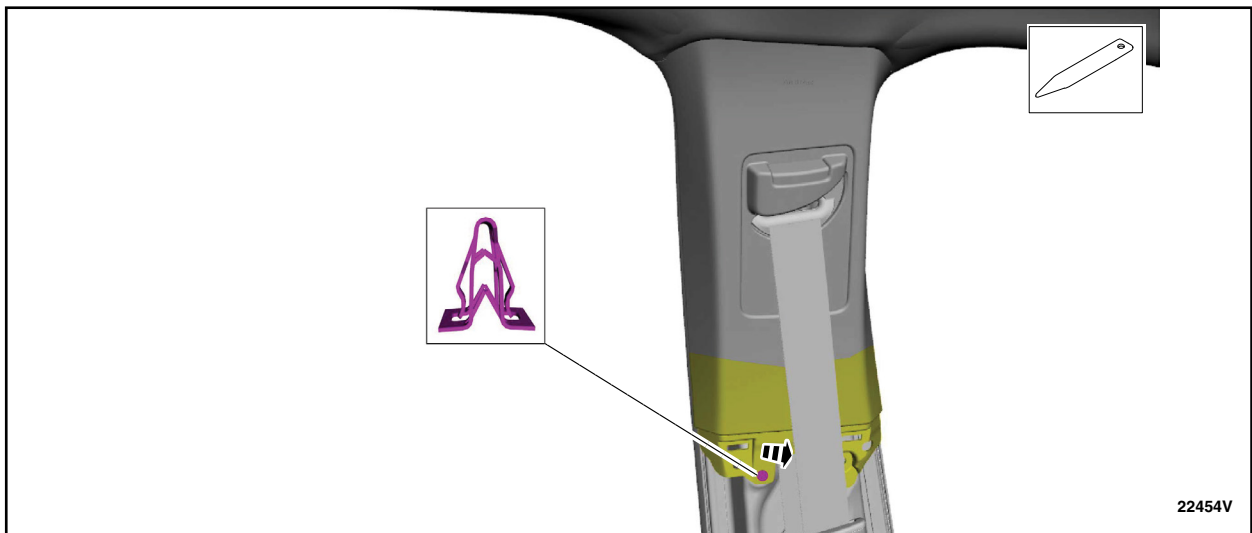

FIGURE 3



NOTICE: The B-pillar upper trim panel must be positioned downward to allow the upper clips to release correctly. Failure to follow this direction may cause damage to the B-pillar upper trim panel.

7. On both sides slide the B-pillar upper trim panel down, aligning the clips to the slots in the sheet metal. See Figure 4.

NOTE: LH side shown, RH side similar.

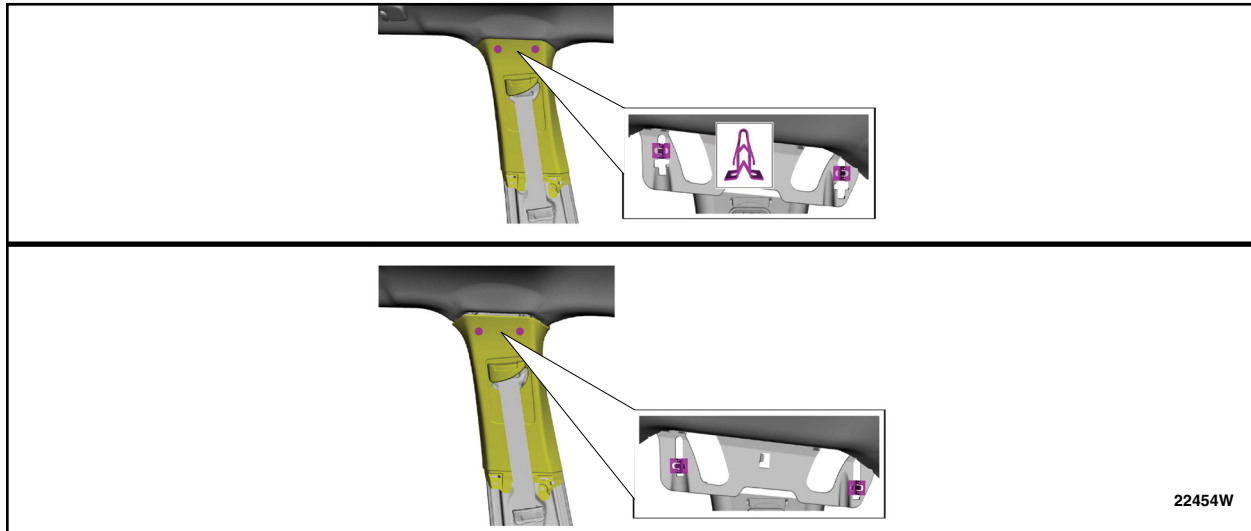

FIGURE 4

8. On both sides pull outward on the B-pillar upper trim panel, feed the front seatbelt retractor and pretensioner through the opening in the B-pillar upper trim panel and remove the B-pillar upper trim panel. See Figure 5.

NOTE: LH side shown, RH side similar.



FIGURE 5



9. On both sides adjust the position of the B-pillar Slider downward, pull the slider down to the lower position and engage the B-side hook into the pocket. See Figure 6.

NOTE: LH side shown, RH side similar.

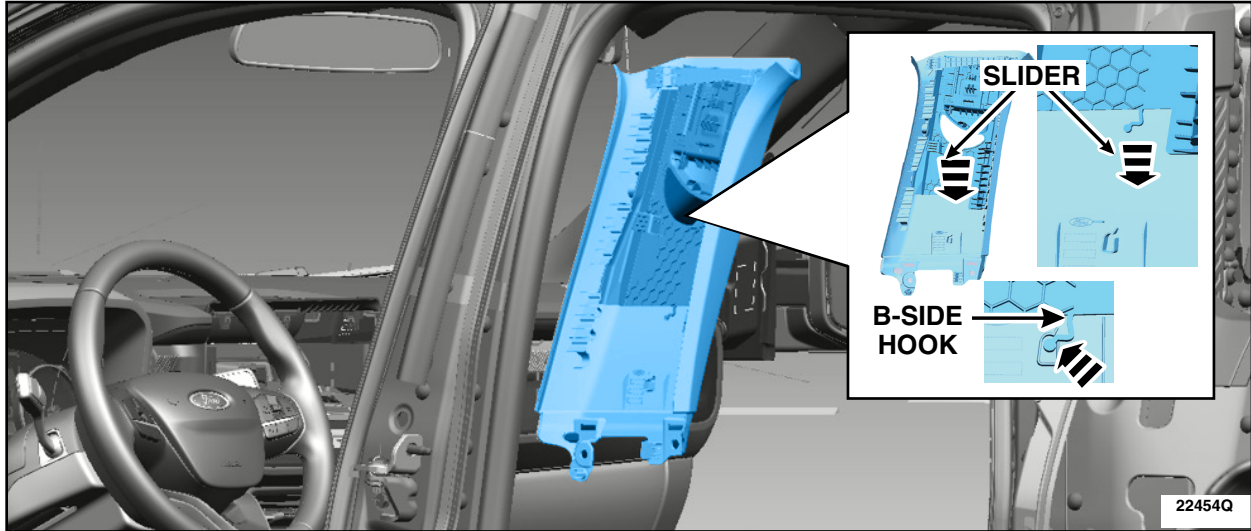

FIGURE 6

10. On both sides pull the height adjuster downward to the lower position and adjust the position of the height adjuster downward. See Figure 7.

NOTE: LH side shown, RH side similar.

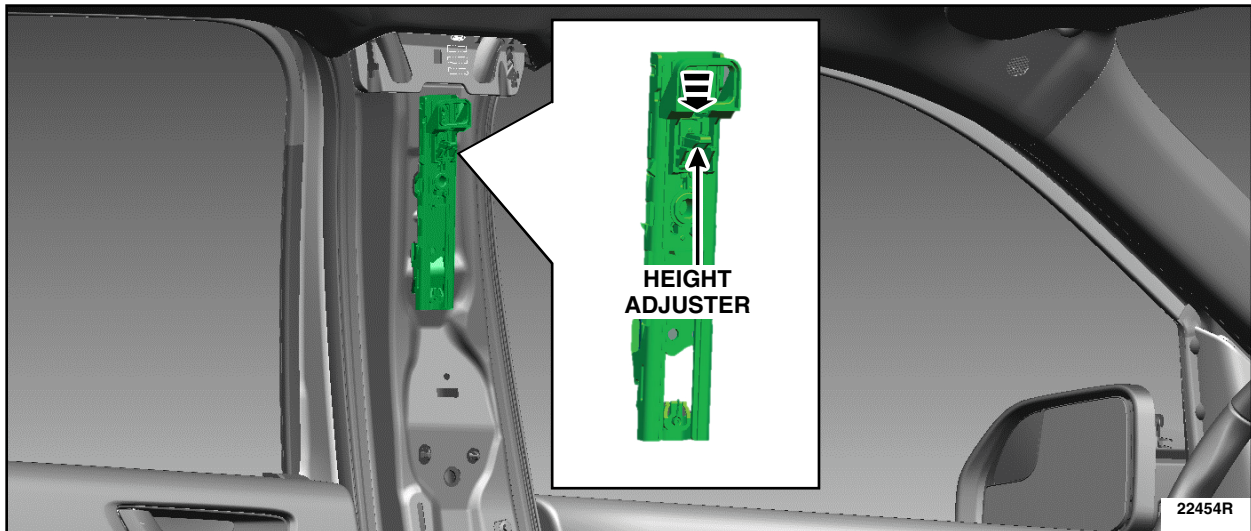

FIGURE 7



11. On the LH side disconnect the headliner wiring harness electrical connector, release the headliner wiring harness from the A-pillar and position the headliner wiring harness aside. See Figure 8.

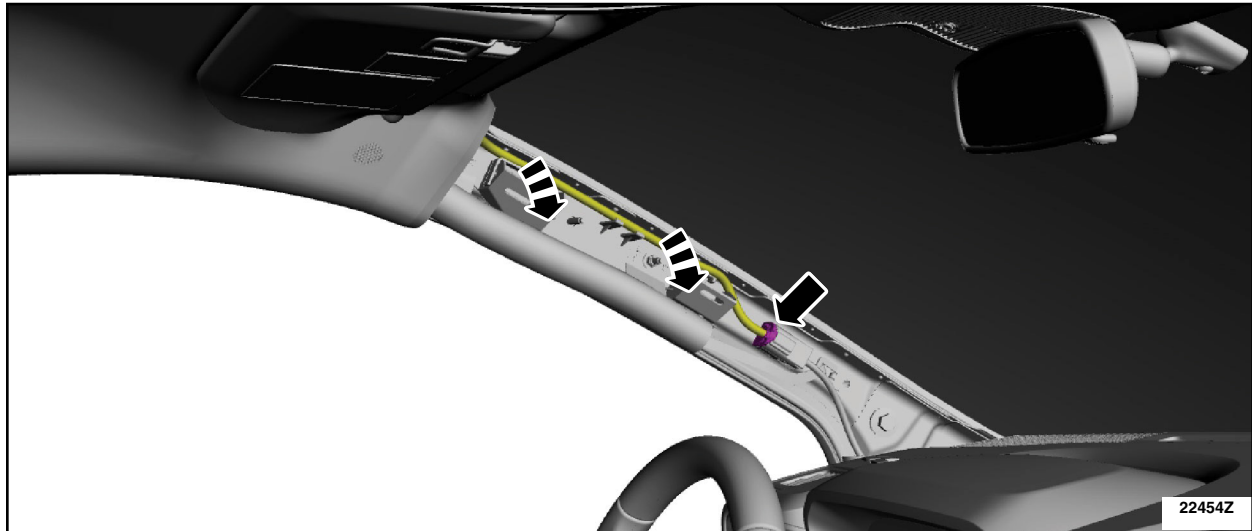

FIGURE 8

12. On both sides position the sun visor bolt cover aside, remove the sun visor bolt, rotate the sun visor end down and rearward to remove from headliner, if equipped disconnect the sun visor electrical connector and remove the sun visor. See Figure 9.

NOTE: LH side shown, RH side similar.

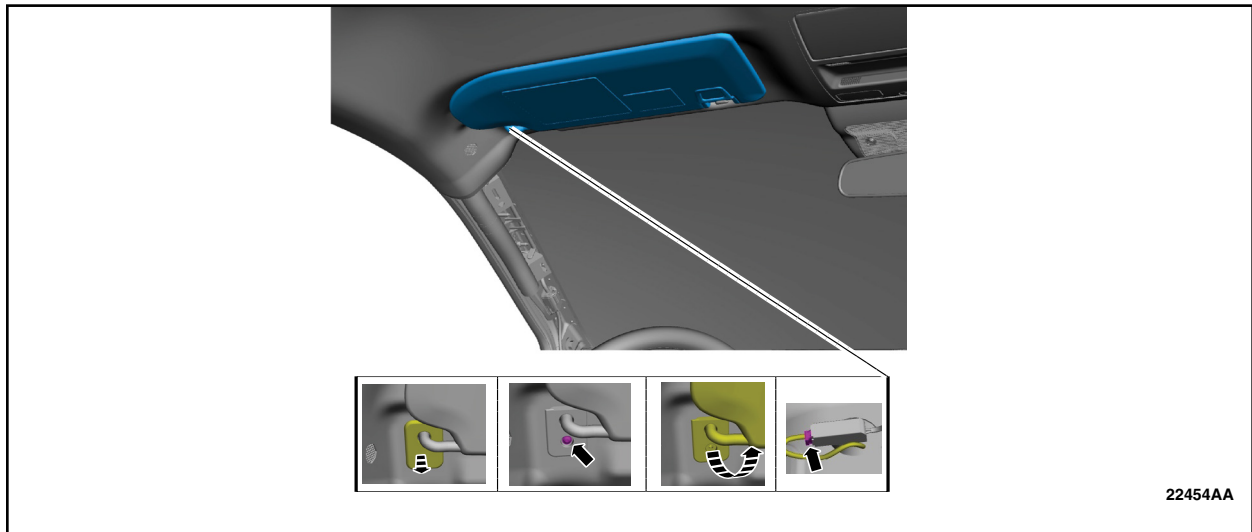

FIGURE 9



13. On both sides remove the bolt and the sun visor clip. See Figure 10.

NOTE: LH side shown, RH side similar.

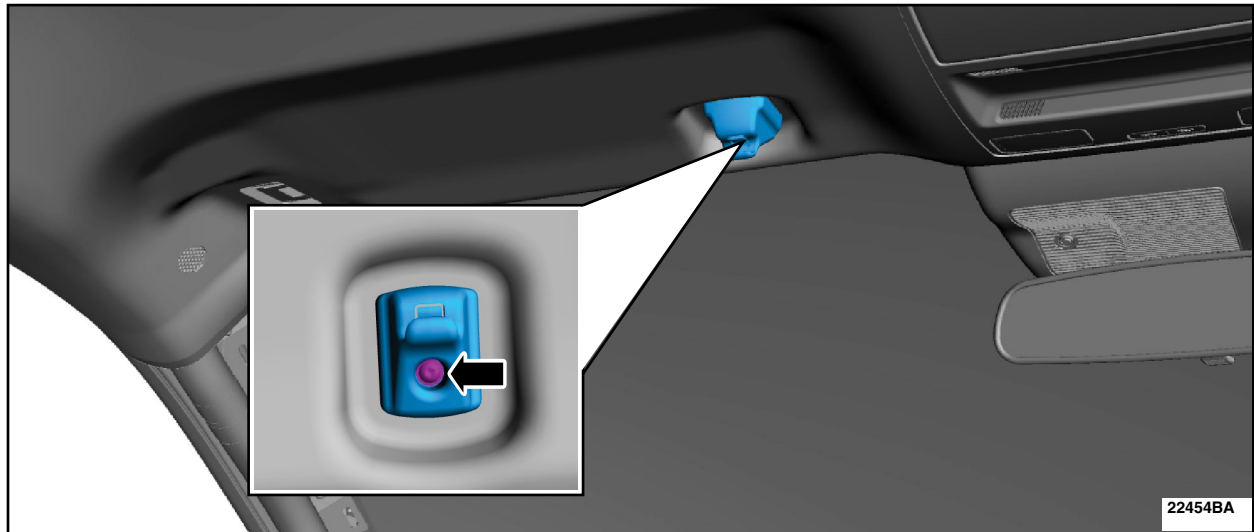

FIGURE 10

14. Release the clips and remove the Image Processing Module A (IPMA) cover. See Figure 11.

NOTE: Interior rear view mirror removed for clarity.

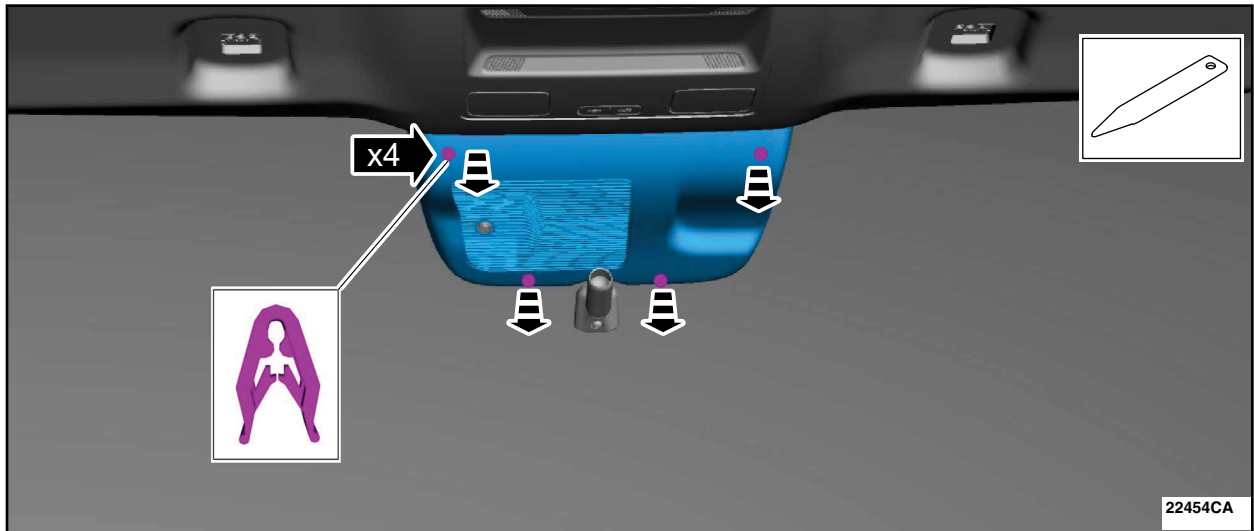

FIGURE 11



15. Disconnect the in-vehicle temperature and humidity sensor electrical connector, the IPMA electrical connector and the IPMA windshield heater grid electrical connector. See Figure 12.

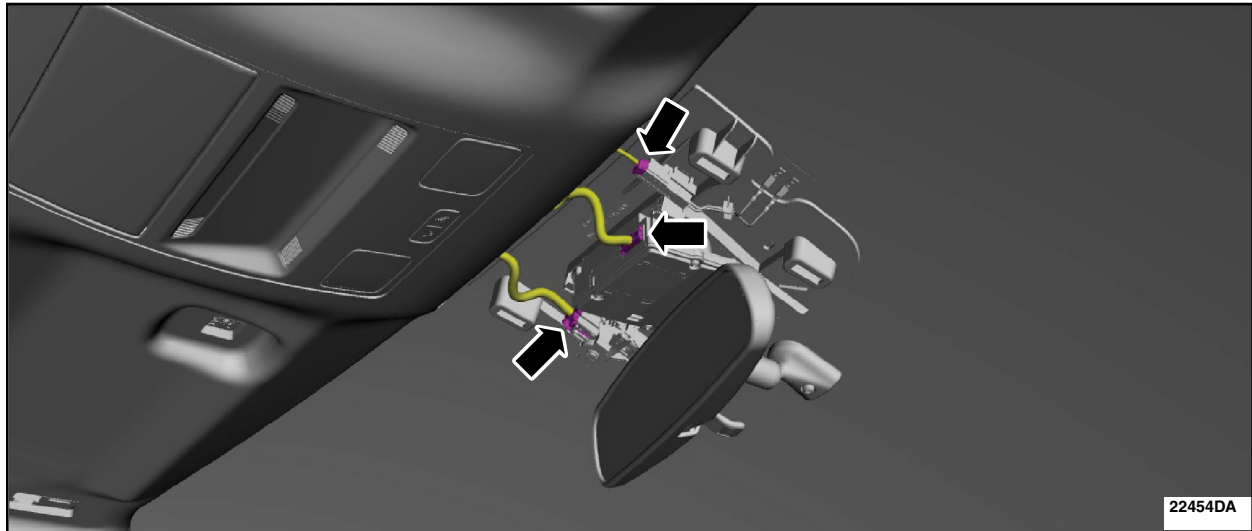

FIGURE 12

16. On the RH side disconnect the headliner wiring harness electrical connector, release the headliner wiring harness from the A-pillar and position the headliner wiring harness aside. See Figure 13.

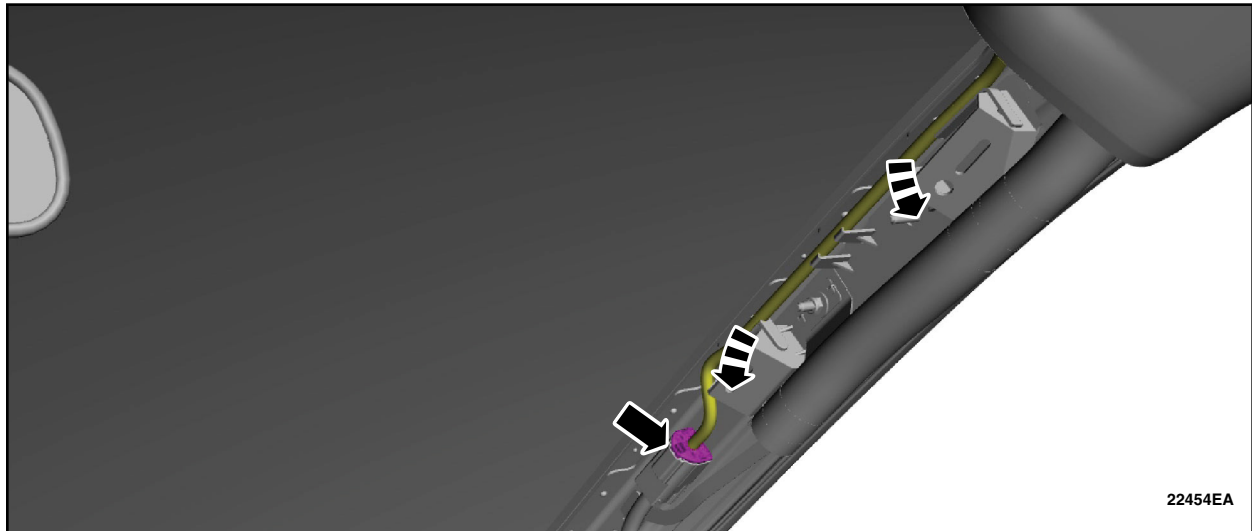

FIGURE 13



17. On the RH side position the front assist handle down, remove the front assist handle retainers and remove the front assist handle. See Figure 14.

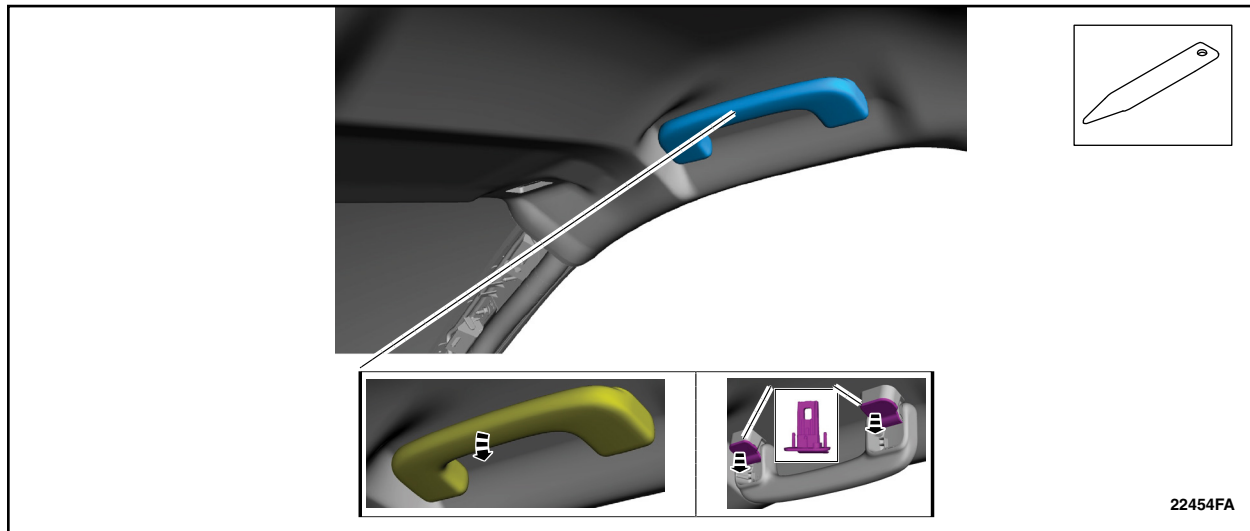

FIGURE 14

18. On both sides position the rear assist handle down, remove the rear assist handle retainers and remove the rear assist handle. See Figure 15.

NOTE: LH side shown, RH side similar.

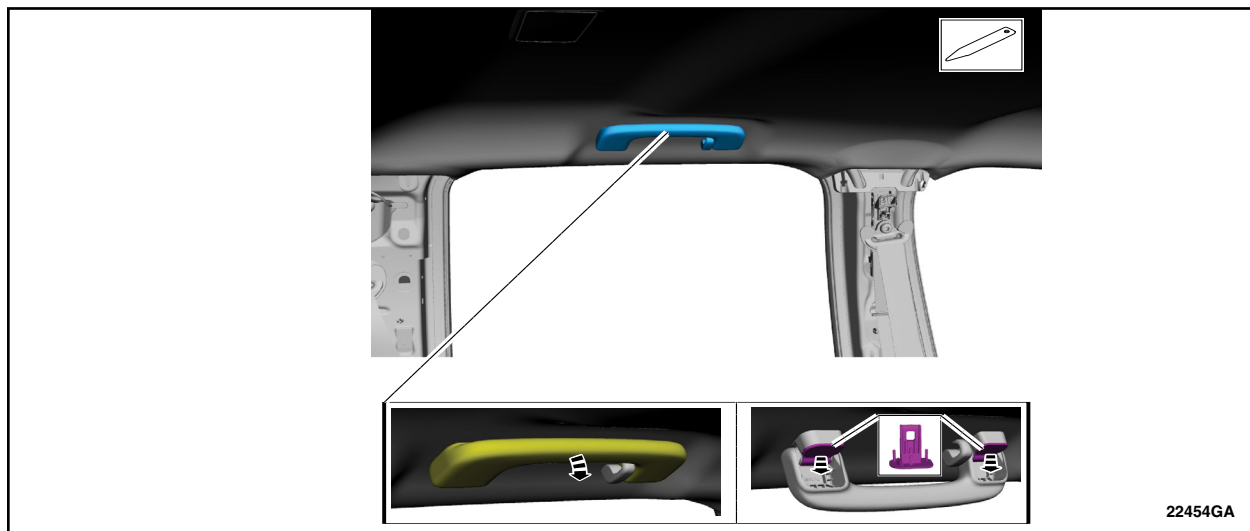

FIGURE 15



NOTE: For this procedure only **DO NOT** remove the C-Pillar upper trim panel.

19. Release the headliner rear clips. See Figure 16.

NOTE: C-Pillar upper trim panel removed for clarity.

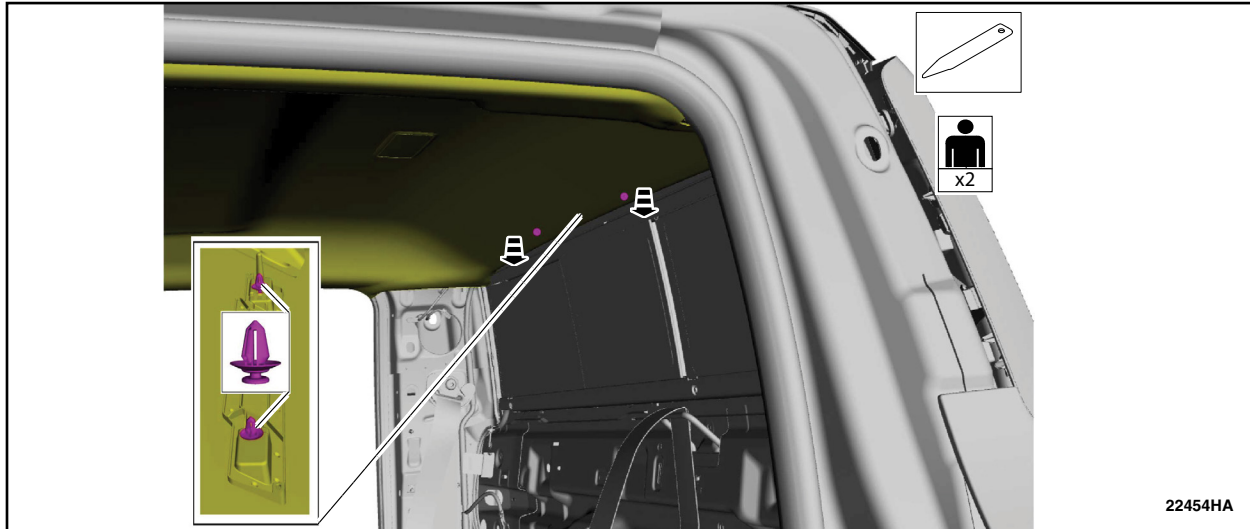

FIGURE 16

NOTE: The use of an assistant is recommended to support the front of the headliner while the rear is being lowered around the C-Pillar upper trim panel.

20. Lower the headliner. See Figure 17.

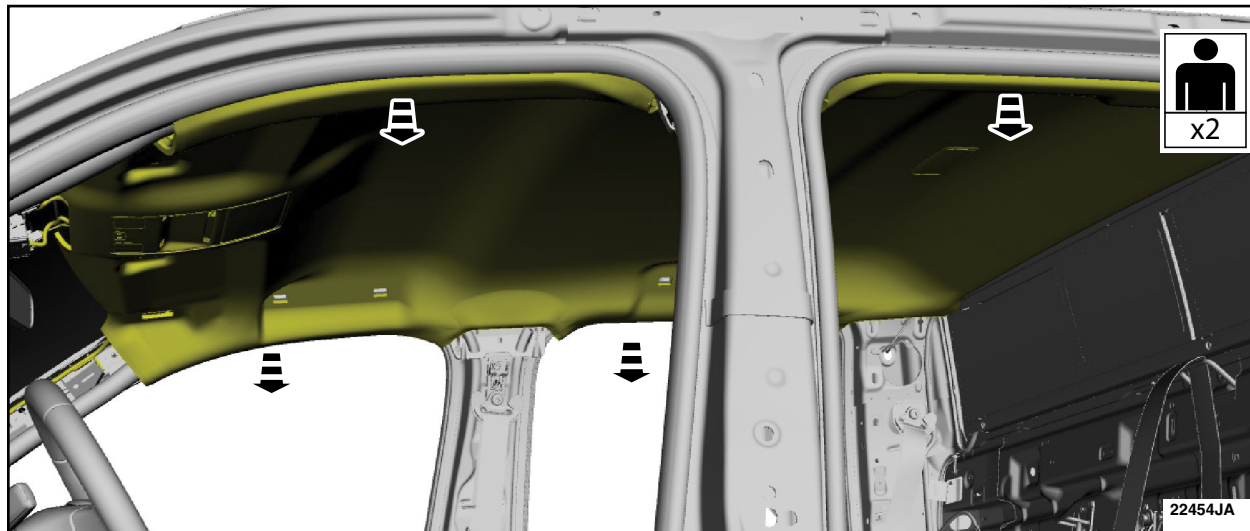

FIGURE 17

21. Remove the driver and passenger side Side Curtain Airbags. Please follow the WSM procedures in Section 501-20B.



NEW ! 22. On both sides of the headliner, remove and discard the foam block located rearward of the B-Pillar upper trim panel. *See Figures 18 and 19.*

NOTE: RH side shown, LH side similar.



FIGURE 18

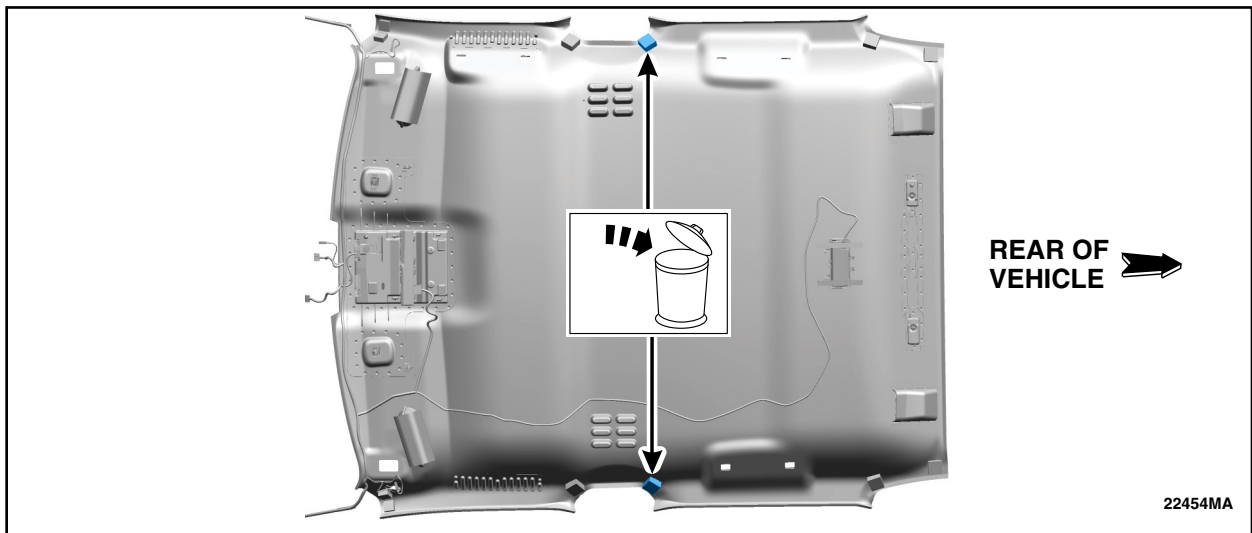

FIGURE 19



23. On both sides of the headliner, measure inward 0.11 in (3mm) across the three *triangular* notches from the edge of the headliner rearward of the B-Pillar upper trim panel and using a suitable tool remove the excess material *including the three triangular notches*. See Figure 20.

NOTE: RH side shown, LH side similar.



FIGURE 20

NOTE: Excess fabric is acceptable and will be covered when the B-Pillar is reinstalled. See Figure 21.

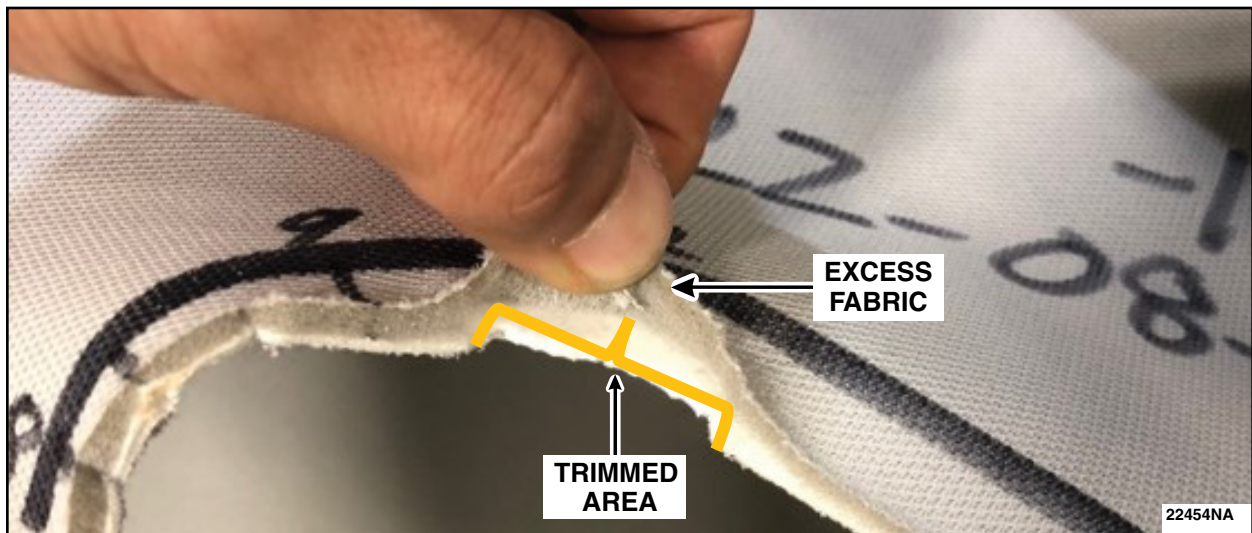

FIGURE 21



24. On both sides of the front of the headliner, locate the large foam block on the outboard edge of the headliner. Measure from the top of the foam block inward 0.28 in (7mm) and mark the foam block. Using a suitable tool cut from the marked area to the top of the foam block. See Figure 22.

NOTE: RH side shown, LH side similar.

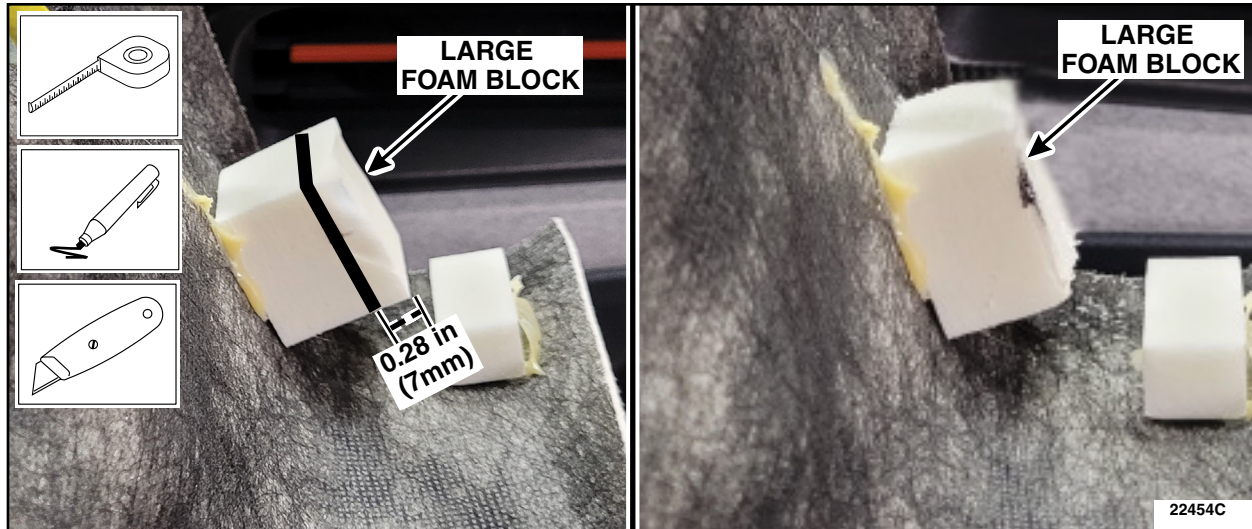

FIGURE 22

25. On both sides of the vehicle remove and discard the A-Pillar bolt. See Figure 23.

NOTE: This hole will be used when installing the *new* side curtain airbags.

NOTE: RH side shown, LH side similar.

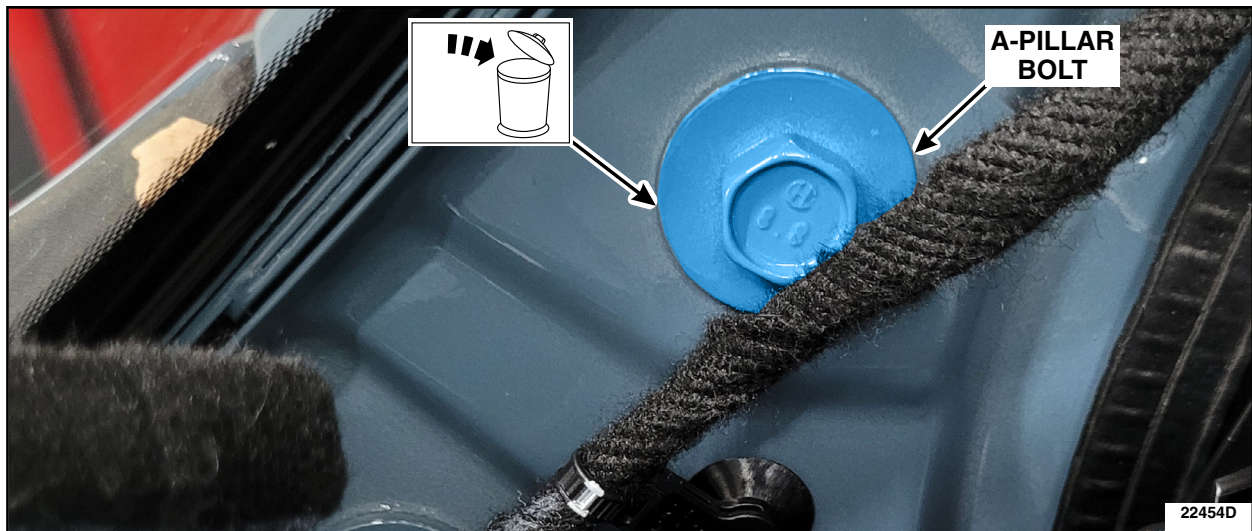

FIGURE 23



26. Slide the *new* side curtain airbag rearward, engaging the retainer to the sheet metal, then rotate the side curtain airbag and attach the retainer. See Figure 24.

NOTE: LH side shown, RH side similar.

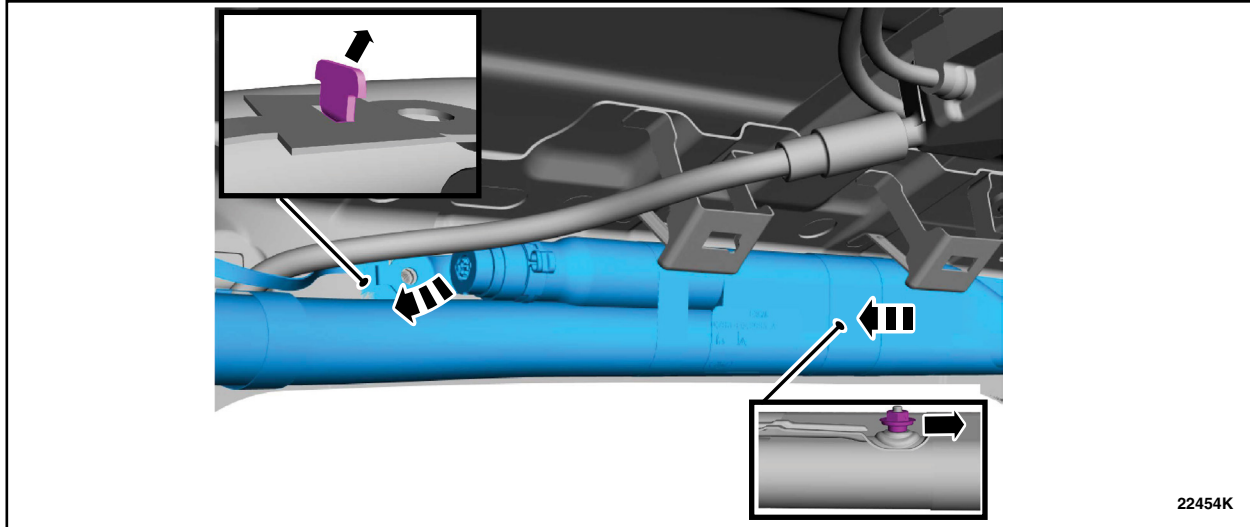

FIGURE 24

27. Install the side curtain airbag rear bolts *in the sequence shown*. See Figure 25.

- Torque: 9 Nm (80 in.lb).

NOTE: LH side shown, RH side similar.

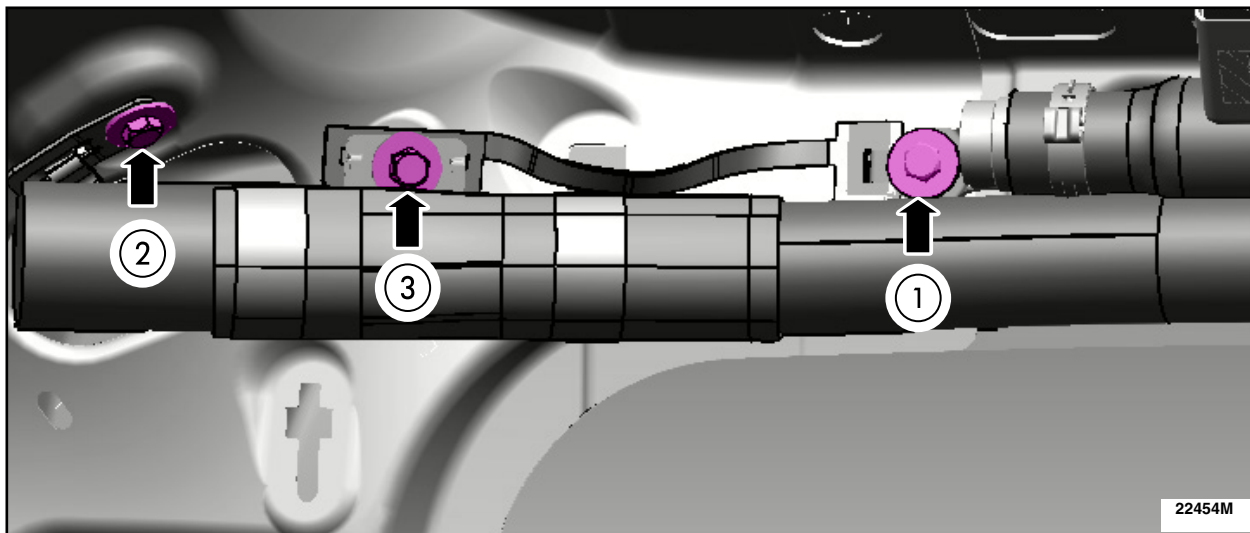

FIGURE 25



28. Attach the *new* side curtain airbag to the hangers *in the sequence shown*. See Figure 26.

NOTE: LH side shown, RH side similar.

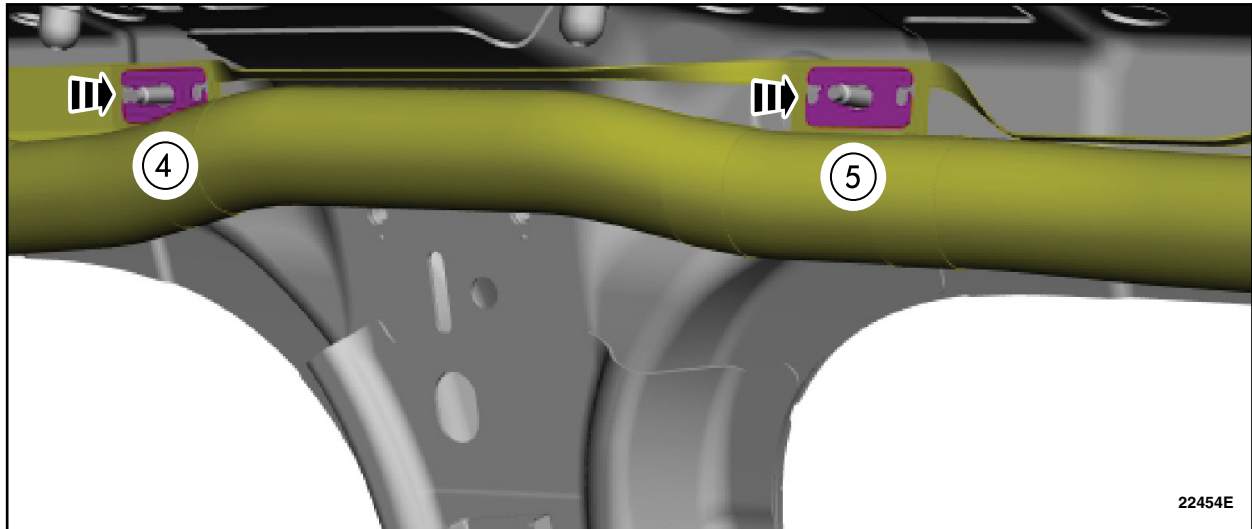

FIGURE 26

29. Using the *new* 50 torx plus bolt attach the *new* side curtain airbag lower tether *and hand tighten the bolt*. See Figure 27.

NOTE: RH side shown, LH side similar.

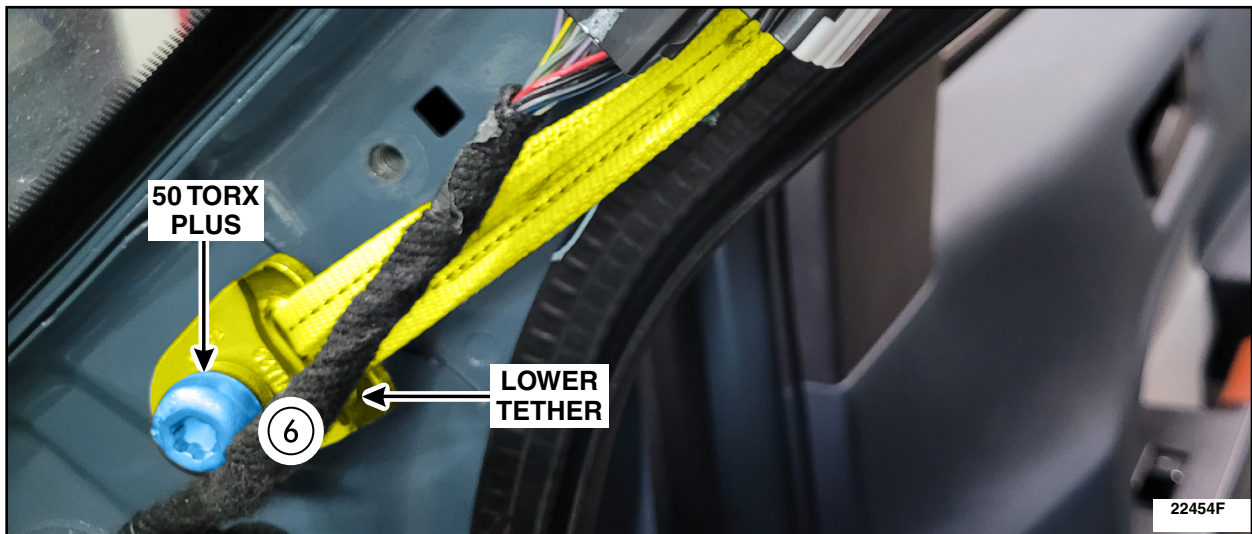

FIGURE 27



30. Attach the *new* side curtain airbag hanger. See Figure 28.

NOTE: LH side shown, RH side similar.

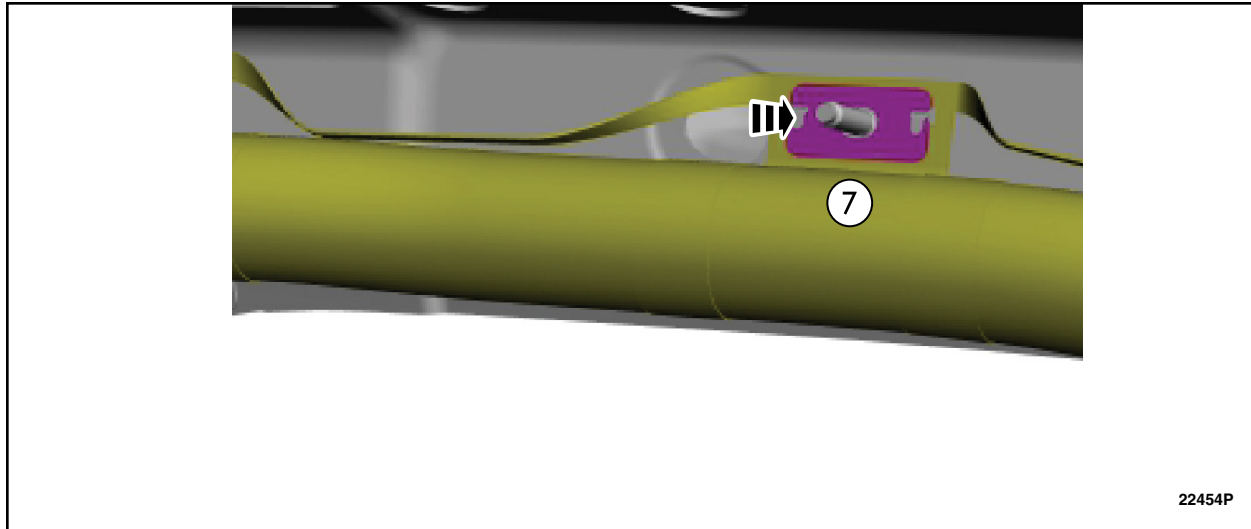

FIGURE 28

31. Attach the *new* side curtain airbag hangers. See Figure 29.

NOTE: Ensure that the upper tether is not twisted during installation.

NOTE: LH side shown, RH side similar.

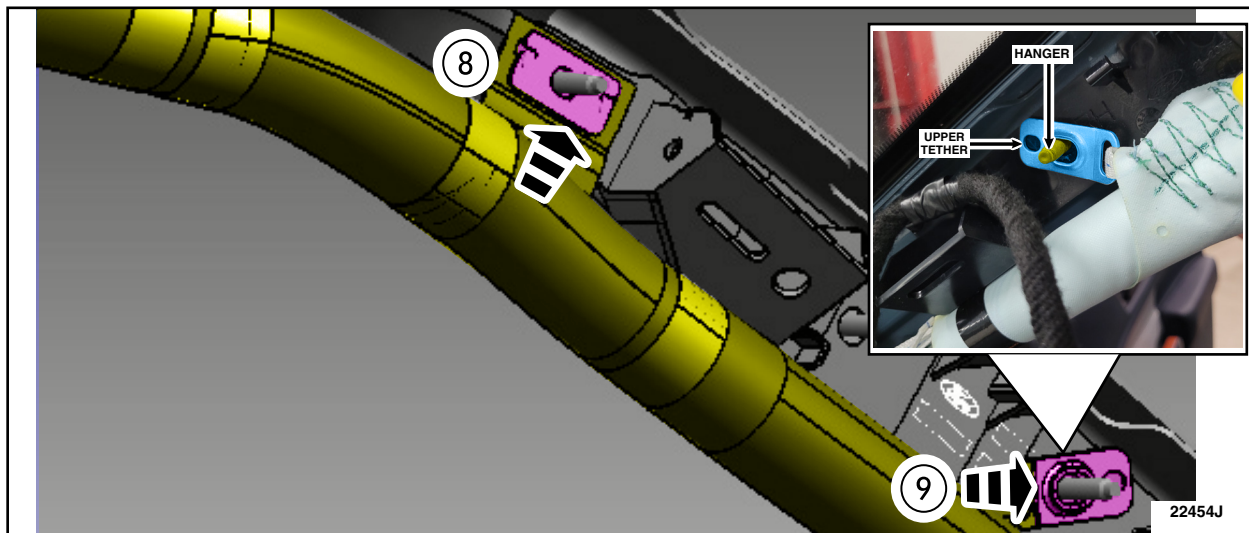

FIGURE 29



32. Attach the *new* side curtain airbag pin-type retainer. See Figure 30.

NOTE: RH side shown, LH side similar.

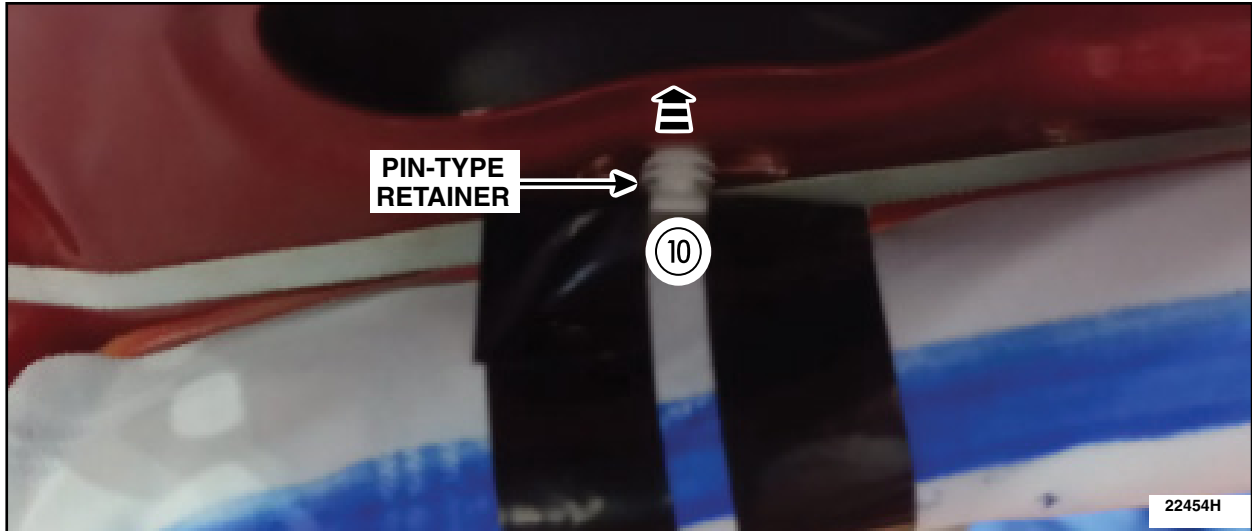

FIGURE 30

33. Using the new 50 torx plus bolt attach the new side curtain airbag lower tether. See Figure 31.

• Torque: 47.5 Nm (35 lb.ft).

NOTE: RH side shown, LH side similar.

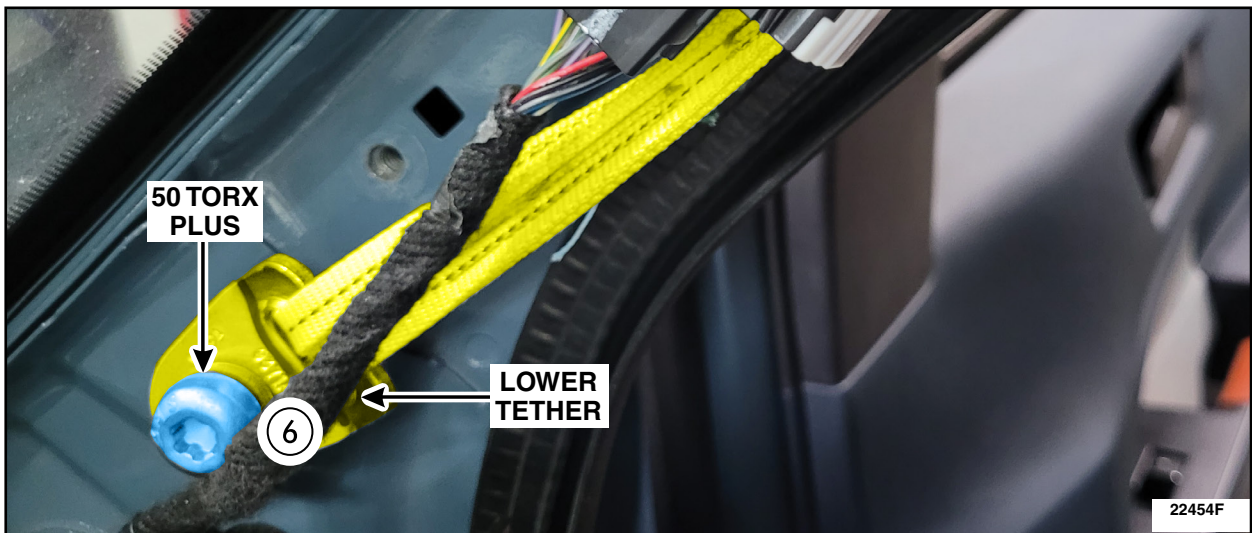

FIGURE 31



34. Install the side curtain airbag nuts. See Figure 32.

- Torque: 9 Nm (80 in.lb).

NOTE: LH side shown, RH side similar.

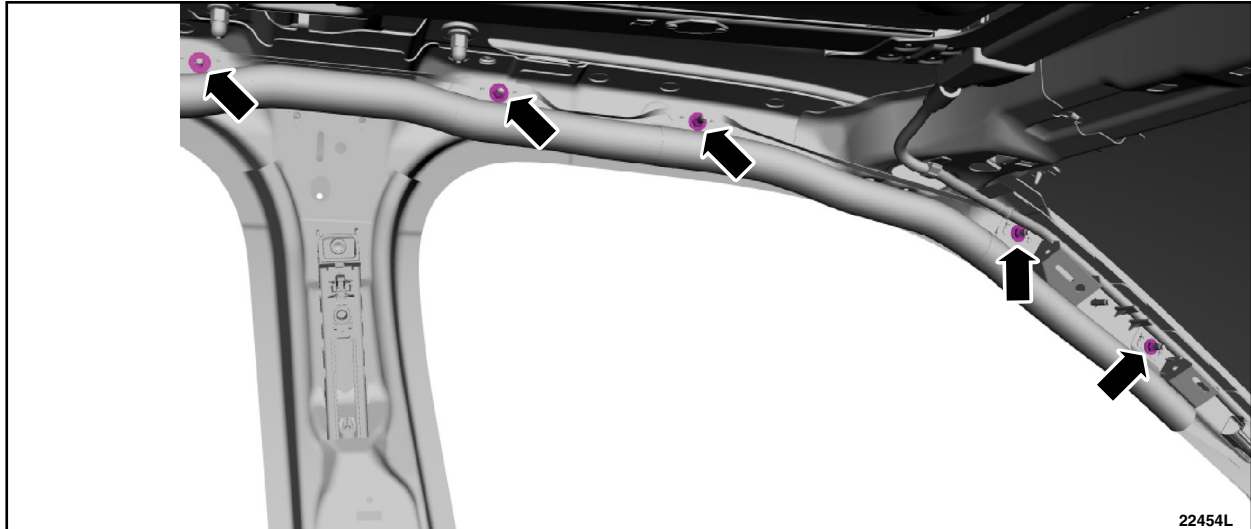

FIGURE 32

35. Connect the side curtain airbag electrical connector and ensure that the spring-loaded locking tabs have engaged. See Figure 33.

NOTE: LH side shown, RH side similar.

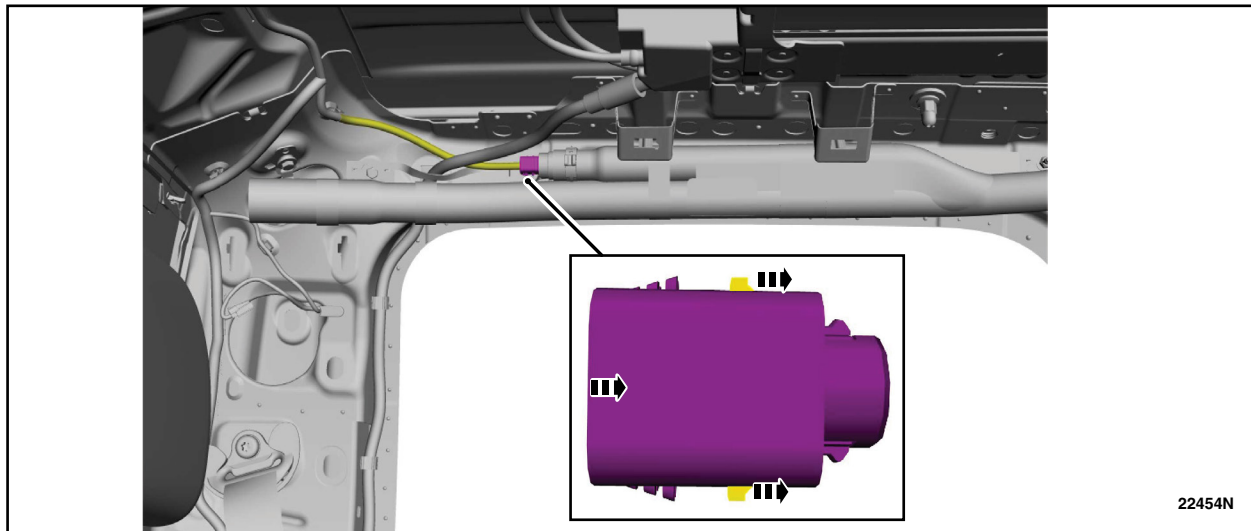

FIGURE 33



NOTE: The use of an assistant is recommended to support the front of the headliner while the rear is being installed around the C-Pillar upper trim panel.

36. Install the headliner by reversing Steps 1-20.

NOTE: When installing the B-Pillar upper trim ensure the correct connection between the height adjuster and B-Pillar upper trim. See Figure 34.

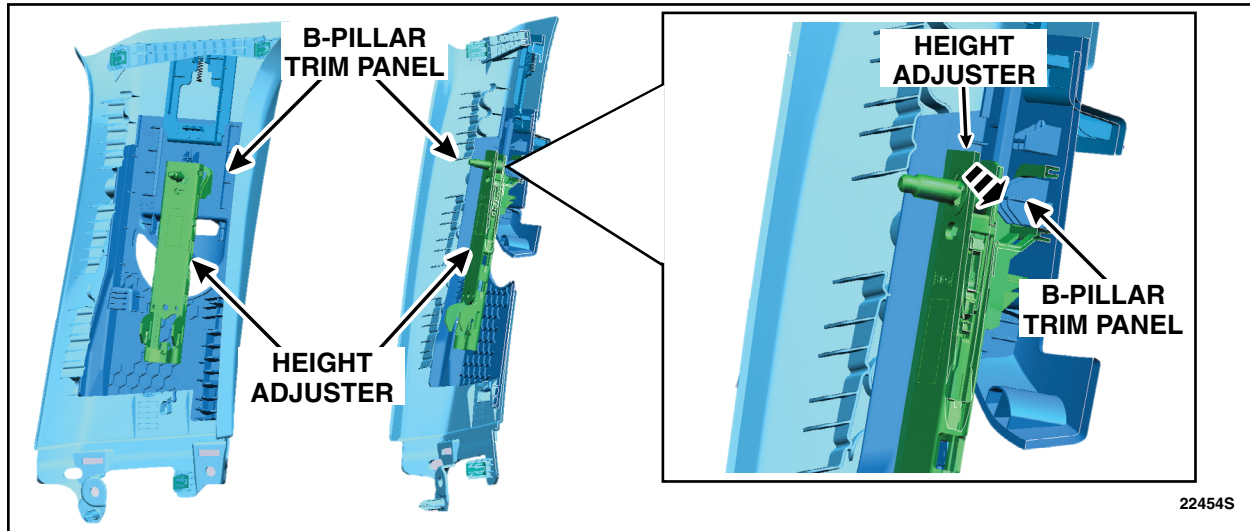

FIGURE 34

NOTE: When reassembled, ensure that the B-pillar clips are correctly inserted in the T shape slots. An audible “click” must be heard when correctly reassembled. See Figure 35.

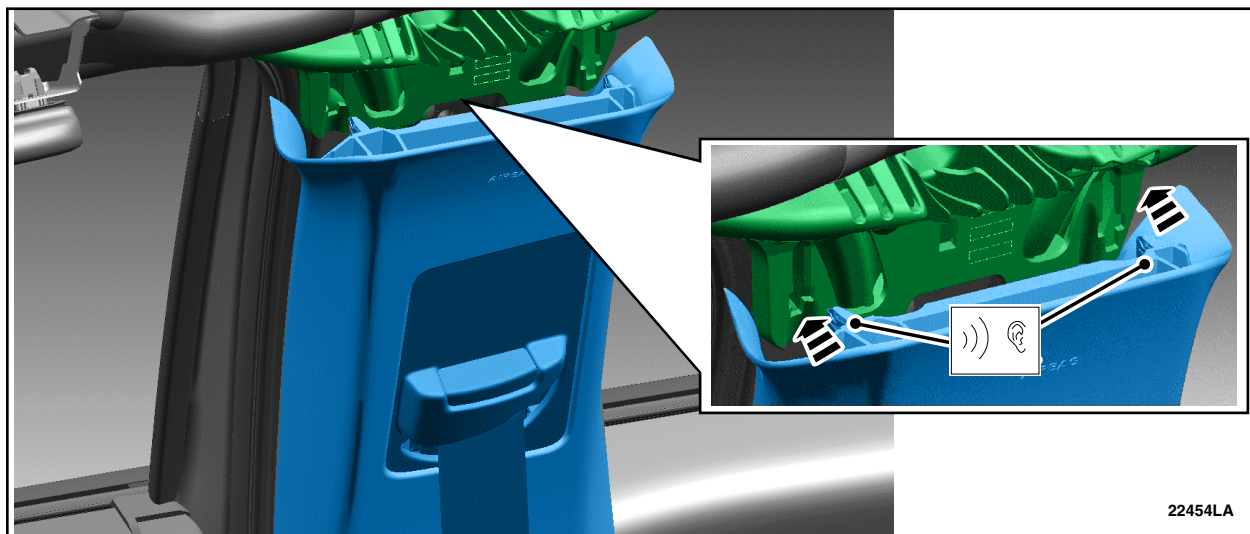

FIGURE 35



38. Slide the B-Pillar Upper Trim, Up and Down three times to ensure they were properly assembled.
See Figure 36.

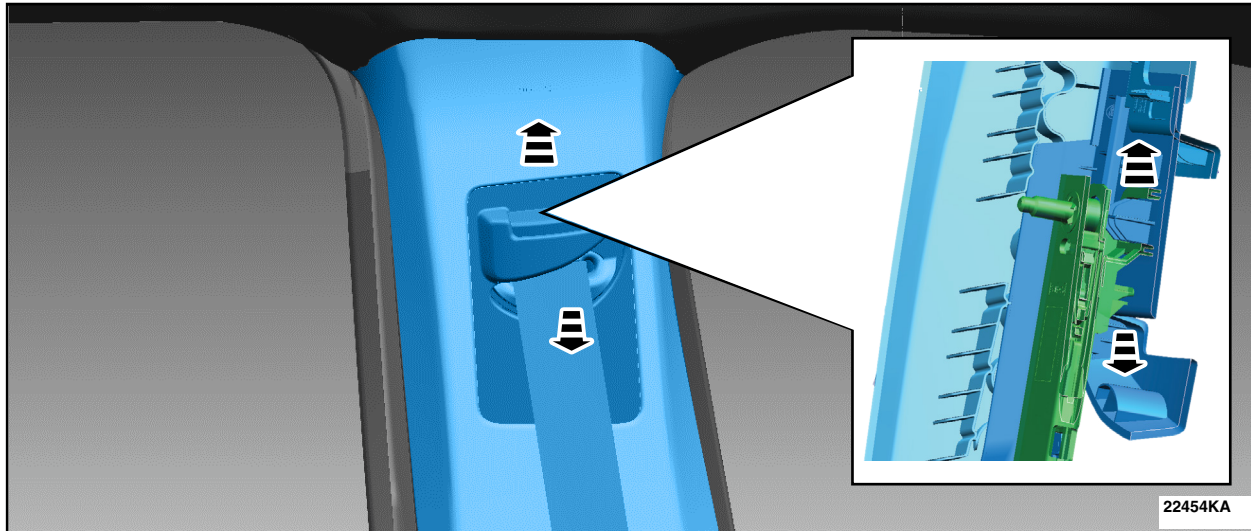

FIGURE 36

39. Inspect and position the front and rear door weather strip lips so that they overlap the top of the B-pillar upper trim panel. See Figure 37.



FIGURE 37



40. Repower the SRS. Please follow the WSM procedures in Section 501-20B.

41. Check the seatbelt system for correct operation. Please follow the WSM procedures in Section 501-20A.

IMPORTANT NOTE: Federal law prohibits selling motor vehicle parts or components that are under safety, compliance, or emissions recall. Unless a part is requested to be returned to Ford, all parts replaced under this FSA must be scrapped in accordance with all applicable local, state and federal environmental protection and hazardous material regulations. Refer to the Parts Retention, Return, & Scrapping section of the FSA dealer bulletin for further information.



Ford Motor Company
Recall Reimbursement Plan for 22C20

Ford and Lincoln's dealers are in the best position to process reimbursement requests quickly and efficiently. However, federal legislation requires all motor vehicle manufacturers to establish processes through which customers may seek recall reimbursement directly from the manufacturer or from the dealers.

Regarding the specific reimbursement plan for Recall # 22C20, owners who have paid for service to remedy the defect or noncompliance must have had that service performed prior to February 10, 2023. After this date, if repairs related to this recall are performed by a non-Ford repair facility in an emergency situation, customers must submit any refund requests through their dealership. As required by this federal regulation, Ford Motor Company submitted the details of its latest General Recall Reimbursement Plan in a letter to the National Highway Traffic Safety Administration (NHTSA) in May 2021. The following is the text of that letter and the Plan:

General Recall Reimbursement Plan
(As submitted to the NHTSA)

Pursuant to the requirements set forth in 49 CFR Part 573 and Part 577 of the Code of Federal Regulations, Ford Motor Company (Ford) is submitting the required information pertaining to our general reimbursement plan for the cost of remedies paid for by vehicle owners before they are notified of a related safety recall.

Set forth below is Ford's general plan to reimburse owners and purchasers for costs incurred for remedies in advance of notification of potential safety-related defects or noncompliance pursuant to Part 573.6 (c)(8)(i). This plan has not changed since our February 20, 2019 submission.

Reimbursement Notification

Ford's notice to a vehicle owner in accordance with 49 CFR Part 577 will indicate that Ford is offering a refund if the owner paid to have service to remedy the defect or noncompliance prior to a specified ending date. In accordance with Part 573.13 (c)(2), this ending date will be defined as a minimum of ten calendar days after the date on which Ford mailed the last of its Part 577 notifications to owners and will be indicated in the specific reimbursement plan available to owners for an individual recall. This notice will direct owners to seek eligible reimbursement through authorized dealers or, at their option, directly through Ford at the following address:

Ford Motor Company
P.O. Box 6251
Dearborn, MI 48121-6251

Ford notes that this rule allows for the identification of a beginning date for reimbursement eligibility. Under the rule, an owner who paid to remedy the defect or noncompliance prior to the identified beginning date would not be eligible for reimbursement. Ford generally has not established such a beginning date for reimbursement eligibility and does not presently anticipate changing this general policy. However, in any case where Ford determines a beginning date is appropriate, Ford will indicate that date in the owner notice. As permitted by 577.11(e), Ford may not include a reimbursement notification when all vehicles are well within the warranty period, subject to approval by the agency.

Costs to be Reimbursed

For vehicles, reimbursement will not be less than the lesser of:

- The amount paid by the owner for the remedy that specifically addressed and was reasonably necessary to correct the defect or noncompliance that is the subject of the recall, or
- The cost of parts for the remedy (to be no more than the manufacturer's list retail price for authorized part(s), plus associated labor at local labor rates, miscellaneous fees (such as disposal of waste) and taxes.

For replacement equipment, reimbursement will be the amount paid by the owner for the replacement item (limited by the amount of the retail list price of the defective or noncompliant item that was replaced, plus taxes, where the brand or model purchased by the owner was different than the brand or model that was the subject of the recall). If the item of motor vehicle equipment was repaired, the reimbursement provisions identified above for vehicles will apply.

Ford notes that costs incurred by the owner within the period during which Ford's original or extended warranty would have provided for a free repair of the problem will not be eligible for reimbursement, as provided by Part 573.13 (d)(1).

Entities Authorized to Provide Reimbursement

Ford will continue to use authorized dealers to reimburse owners under the specific reimbursement plans for a particular recall, and will encourage owners to pursue requests for reimbursement directly through dealers to expedite reimbursement. Ford will also provide a mailing address to which customers can, at their option, send requests for reimbursement directly to Ford, as previously noted. Requests for reimbursement sent directly to Ford may take up to 60 days to process. Whether the owner chooses to pursue reimbursement requests through a dealer or directly through Ford, the owner will be directed to submit the required documentation, upon which reimbursement eligibility will be determined.

Required Documentation

The reimbursement determination will depend upon the information provided by the customer. Consistent with Part 573.13 (d)(4) the following information must be submitted:

- Claimant name and address
- Vehicle make, model, and model year
- Vehicle identification number (VIN) and, for replacement equipment, a description of such equipment or, for tires, the model, size and TIN (DOT code)
- Identification of the recall number (either the Ford recall number or the NHTSA recall number)
- Identification of the owner of the recalled vehicle at the time that the pre-notification remedy was obtained
- An original receipt for the pre-notification remedy that includes a breakdown of the amount for parts, labor, other costs and taxes, including costs for the replacement item. Where the receipt covers work other than to address the recall or noncompliance, Ford may require the claimant to separately identify costs that are eligible for reimbursement.
- If the remedy was obtained during the warranty period, documentation indicating that the warranty was not honored or the warranty repair did not correct the problem related to the recall.

Failure to submit all of the above information may result in denial of the reimbursement request.

Additional Information

The Part 577 required owner notice will provide a toll-free telephone number through which specific information about the reimbursement plan can be requested from Ford. This general reimbursement plan will be incorporated into notifications pursuant to Part 573.6 by reference. Information specific to an individual recall also may be incorporated into the Part 573.6 notification.