

SAFETY RECALL NOTICE



10101 Science Drive
Sturtevant, Wisconsin 53177
USA

www.brp.com

July 14, 2022

Re: Handlebar Stem Bolt May Break - Potential Loss of Steering Control

Dear BRP Dealer/Distributor,

This notice is sent to you in accordance with the requirements of the *Motor Vehicle Safety Act* (Canada), the National Traffic and Motor Vehicle Safety Act (United States) and other applicable laws. BRP has decided that a defect, which relates to motor vehicle safety, exists in some vehicles and is conducting a safety recall.

What is the potential problem?

The handlebar stem bolt may break suddenly. This could lead to a loss of steering control and increase the risk of a crash.

Which models are involved?

Certain serial numbers of Model Year 2022 Can-Am® Ryker vehicles

What is the solution?

- BRP will repair, without cost, the involved vehicles.
- The repair is to clean the threads of the steering column and to install the new handlebar stem bolt. It will take less than 1 hour to complete.
- Do not deliver any new involved vehicle before the repair.

What should you do?

- Read the Safety Campaign Bulletin.
- Refer to Campaign Monitoring to validate involved vehicle serial numbers.
- Contact all of your customers who purchased an affected vehicle. You must inform your customers about:
 - The safety recall
 - **The importance of not riding their vehicle until the recall is performed**
- FOR US AND CANADA: If your customer needs help to tow their vehicle to your dealership, they should contact BRP Roadside Assistance at 1-866-477-1415.
- FOR OTHER MARKETS: BRP will offer a fixed credit for towing expenses. Please refer to the bulletin.

What will BRP do for customers?

- Within direct markets: BRP will send a safety recall letter to all known registered owners.
- Within distributor markets: BRP is notifying its distributors. The distributors are then responsible to deploy the safety recalls in their respective markets and must follow all legal requirements.
- Information for customers will be posted on the Can-Am On-Road public websites.

BRP prides itself on being an industry leader and providing you, as well as our customers, with the very best information so we can collectively preserve the reputation of our products.

We apologize for any inconvenience this may have caused you or your customers.

Sincerely,

BRP Customer Services Department

If you have questions about this notice, please communicate with us:

- By submitting a Technical Support Request/Report incident in **BOSSWeb**.
A service representative will communicate with you.

OR

- 1-800-366-6992
Eastern time Monday to Friday from 10:00 AM to 5:00 PM



WARRANTY BULLETIN SAFETY CAMPAIGN

⚠ WARNING: All involved customers must be notified, all involved units must be corrected as per instruction herein.

Campaign no.: 2022-0007
2022-0008

July 14, 2022

Subject: **Handlebar Stem Bolt May Break - Potential
Loss of Steering Control**

No. **2022-16**

IMPORTANT

What should you do?

- Do not deliver any involved vehicle that you have in stock as federal law requires you to complete the recall service on these vehicles before retail delivery.
- Customers cannot ride their vehicle until the safety recall procedure has been performed.
- Contact all known customers who have purchased the affected product and inform them about this safety recall notice.

MODEL YEAR	MODEL	ADMISSIBLE UNITS
2022 (only some specific VIN)	Ryker™	Go to BOSSWeb/Warranty/Campaign Monitoring to know the quantity of units in your inventory impacted by this campaign

IMPORTANT

- When a vehicle comes in for service, always type the VIN in Knowledge Center to check for pending campaigns or alerts.
- When performing any work on a vehicle, it is good practice to connect it to BUDS2 to ensure that all needed updates are done.

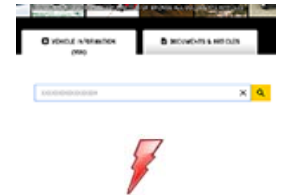

PROBLEM

The handlebar stem bolt may break suddenly. This could lead to a loss of steering control and increase the risk of a crash.

SOLUTION

Clean the threads of the steering column and install the new handlebar stem bolt.

REQUIRED PARTS

Order parts through regular channel.

DESCRIPTION	PART NUMBER
Hardware kit (M8 x 1.25 x 95 bolt and M8 washer)	219800550

CORRECTIVE ACTION

Unregistered Units

1. Blow air into the steering column cavity.
2. Pass a M8 x 1.25 mm tap in the steering column threads.

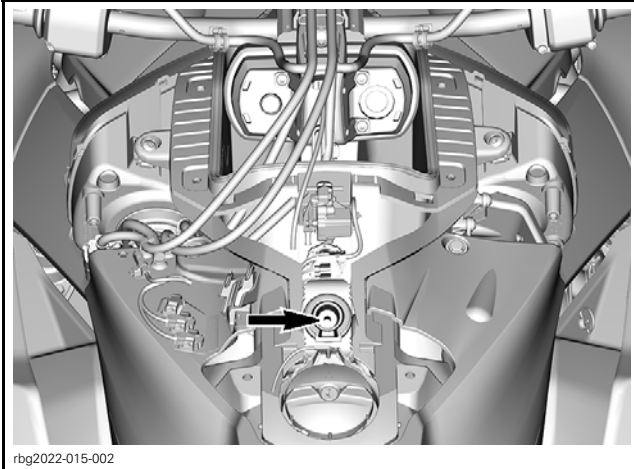

3. Clean the steering column threads using shop rags. Ensure all the debris are removed.
4. Install the washer on the bolt.

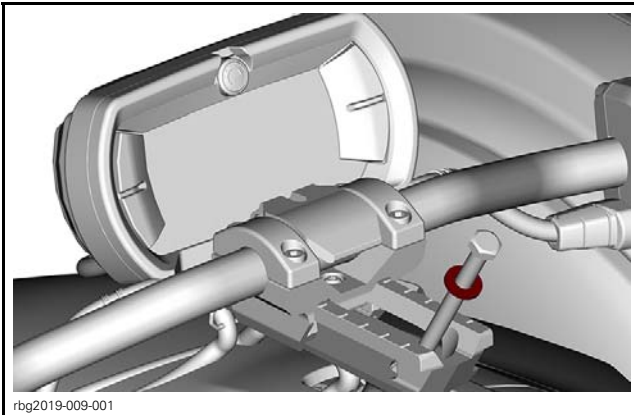

5. Apply a few drops of threadlocker on the bolt threads.

SERVICE PRODUCT
Loctite 243 (blue)

6. Refer to the *RYKER PRE-DELIVERY INSPECTION BULLETIN* to install the handlebar stem bolt on the vehicle.

Registered Units

1. Lock the steering column. Refer to *LOCKING THE STEERING COLUMN* in *STEERING AND FRONT WHEELS* subsection of the appropriate online *SERVICE MANUAL*.
2. Lift locking lever and move handlebar forwards.

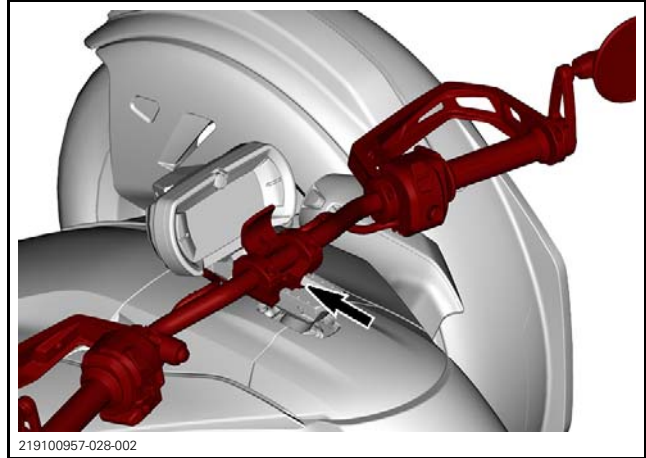

3. Remove the rubber plug.

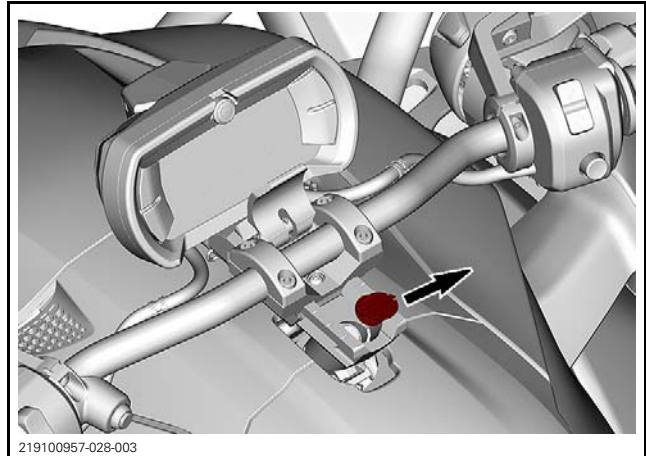

4. Remove and discard the handlebar stem flanged screw.

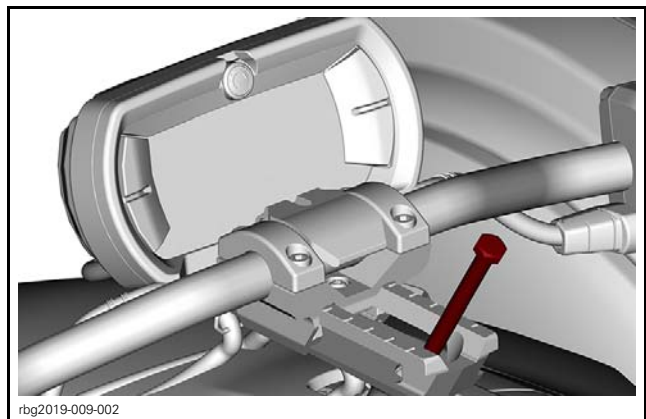

5. Remove the handlebar stem from the steering column. Refer to the *STEERING AND FRONT WHEELS* subsection in the appropriate **online SERVICE MANUAL**.

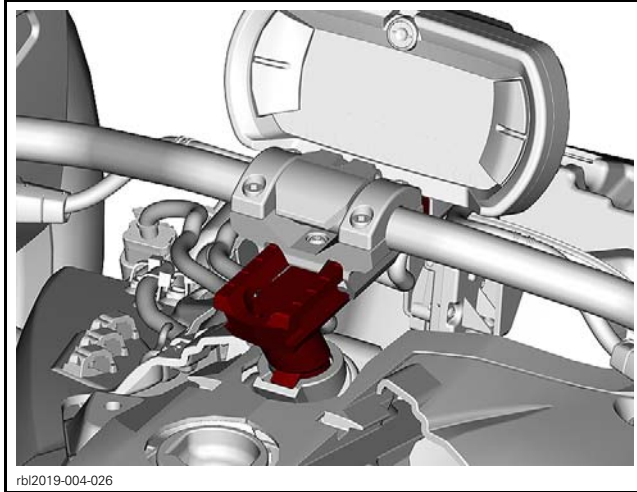

6. Blow air into the steering column cavity.
 7. Pass a M8 x 1.25 mm tap in the steering column threads.

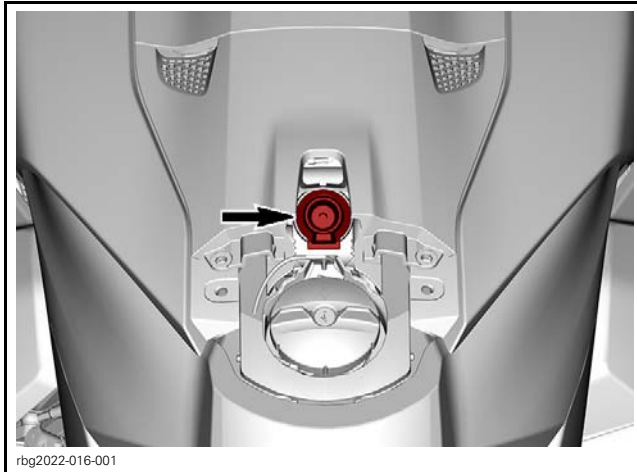

8. Clean the steering column threads using shop rags. Ensure all the debris are removed.
 9. Remove all contaminants using a shop rag and parts cleaner before installing the stem.

SERVICE PRODUCT
XPS Brake and Parts Cleaner

10. Install the handlebar stem into steering column.
 11. Apply threadlocker on the threads.
 12. Install the new bolt with the flat washer.

NOTE: Threadlocker is considered as shop supply and is not claimable.

SERVICE PRODUCT
Loctite 243 (blue)

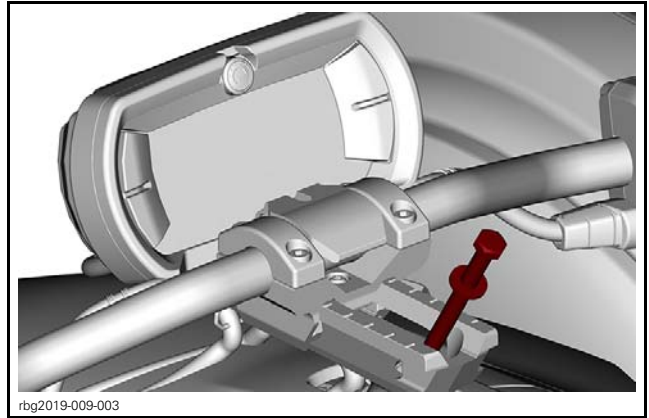

13. Center the handlebar (rotation movement).

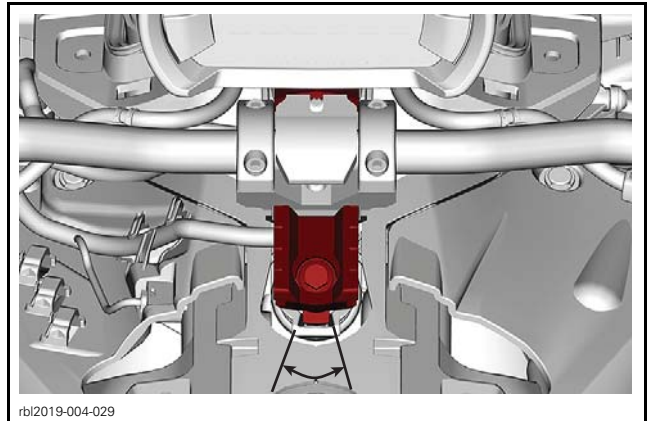

NOTE: Make sure the handlebar is clamped when centering it.

14. Tighten the bolt to specification.

TIGHTENING TORQUE	
Handlebar stem bolt	24 N•m ± 1 N•m (17.7 lbf•ft ± .7 lbf•ft)

15. Reinstall the rubber plug.

16. Position handlebar and lock it in place.

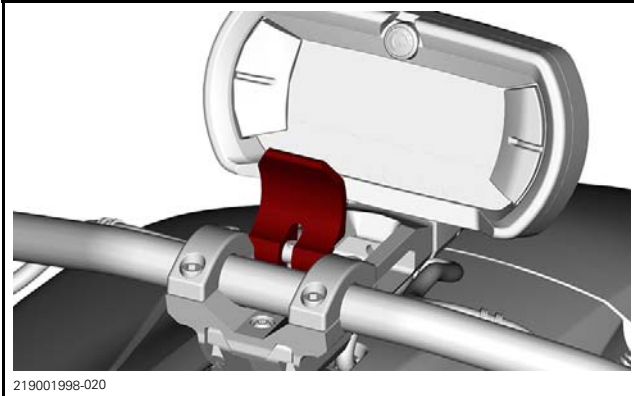

⚠ WARNING
 Be sure that the locking lever is well positioned. It should be equal with the handlebar retaining clamps.

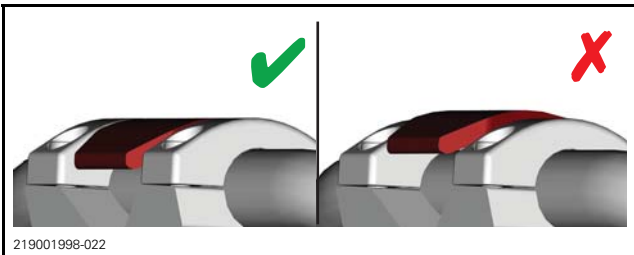

17. Unlock the steering column.

WARRANTY

Submit a warranty claim using the following information.

For claiming procedure, refer to the **online DEALER/DISTRIBUTOR WARRANTY GUIDE**.

All Units - Handlebar Stem Bolt Replacement

Product Line	Roadster
Unit Model Year	2022
Campaign/Bulletin/Description	7 / 2022-16 / Handlebar stem bolt replacement
*Action	
Inspect <input type="checkbox"/>	Repair <input checked="" type="checkbox"/>
Total Labor time paid	0.3 hour

International Registered Units Only (Towing)

NOTE: If needed, use the campaign below for towing expenses **outside** of the United States and Canada.

In the United States and in Canada, customers are instructed to use BRP Roadside Assistance. Make sure to also claim the Handlebar Stem Bolt Replacement campaign separately.

Product Line	Roadster
Unit Model Year	2022
Campaign/Bulletin/Description	8 / 2022-16 / Towing for handlebar stem bolt
*Action	
Inspect <input type="checkbox"/>	Repair <input checked="" type="checkbox"/>
Total Labor time paid	1.5 hour

IMPORTANT SAFETY RECALL NOTICE

This notice applies to your vehicle



10101 Science Drive
Sturtevant, Wisconsin 53177
USA
www.brp.com

July 14, 2022

Re: Handlebar Stem Bolt May Break - Potential Loss of Steering Control

Dear BRP Customer,

This notice is sent to you in accordance with the National Traffic and Motor Vehicle Safety Act. BRP has decided that a defect related to motor vehicle safety exists in the following vehicles. As a result, BRP is conducting a safety recall.

Our records show that you own a potentially affected vehicle.

What is the potential problem?

The handlebar stem bolt may break suddenly. This could lead to a loss of steering control and increase the risk of a crash.

Which models are involved?

Certain serial numbers of Model Year 2022 Can-Am® Ryker vehicles

What should you do?

- Immediately contact your authorized BRP Can-Am On-Road dealer to schedule an appointment to have the safety recall performed on your vehicle.
- The dealer will clean the threads of the steering column and install the new handlebar stem bolt.
- This repair will be at no cost to you.
- This action will take less than 1 hour to complete.

Can I continue to ride my vehicle?

No. BRP highly recommends that you stop riding your vehicle until the recall repair is performed.

If you need help to tow your vehicle to your dealer, use BRP Roadside assistance at 1-866-477-1415.

If you leased this vehicle:

- Send a copy of this letter to the lessee within ten working days after the day you received this letter
- Do the same with any future letters about this safety recall

If, after contacting your dealer and the Customer Assistance Center, you are still not satisfied we have done our best to remedy this condition without charge and within a reasonable time, you may choose to write the Administrator, National Highway Traffic Safety Administration, 1200 New Jersey Avenue, SE., Washington, DC 20590, call the toll-free Vehicle Safety Hotline at 1.888.327.4236 (TTY 1.800.424.9153) or go to <http://www.safercar.gov>. The National Highway Traffic Safety Administration Campaign ID Number for this recall is TBD.

What to do if you feel you have received this notice by mistake:

This notice was mailed to you according to the most current information we have available. If you no longer own this vehicle or some information regarding your name or address are incorrect, please contact BRP at your earliest convenience.

Your safety and continued satisfaction with our products are a priority for us. We apologize for any inconvenience this may cause you and remain committed to facilitating the process as much as we can.

Thank you for your immediate attention to this matter.

Sincerely,

BRP Customer Services Department

If you have questions or need assistance, or to find the nearest authorized BRP dealer:

- Visit www.brp.com
- Or call: 1-888-272-9222
8:00 AM to 8:00 PM Eastern time 7 days a week.