



David J. Johnson
Director
Service Engineering Operations
Ford Customer Service Division

Ford Motor Company
P. O. Box 1904
Dearborn, Michigan 48121

June 28, 2022

TO: All U.S. Ford and Lincoln Dealers

**SUBJECT: NEW VEHICLE DEMONSTRATION / DELIVERY HOLD -
Compliance Recall 22C12**
Certain 2022 Model Year Bronco and Ranger Vehicles
Windshield Adhesion Repair

AFFECTED VEHICLES

Vehicle	Model Year	Assembly Plant	Build Dates
Bronco	2022	Michigan Assembly	December 08, 2021 through April 12, 2022
Ranger			December 17, 2021 through April 12, 2022

Affected vehicles are identified in OASIS and FSA VIN Lists.

REASON FOR THIS COMPLIANCE RECALL

All of the affected vehicles may not conform to the requirements specified by Federal Motor Vehicle Safety Standard (FMVSS) 212 Windshield Mounting, due to the potential for inadequate urethane adhesion around portions of the glass. An improperly adhered windshield may not stay adequately retained in a crash, which may increase the risk of injury to an occupant. Affected vehicles could experience increased wind noise or water leaks.

SERVICE ACTION

Before demonstrating or delivering any new in-stock vehicles involved in this recall, dealers are to remove the windshield and improve the windshield urethane to body adhesion using the attached procedures. This service must be performed on all affected vehicles at no charge to the vehicle owner.

OWNER NOTIFICATION MAILING SCHEDULE

Owner letters are expected to be mailed the week of July 11, 2022. Dealers should repair any affected vehicles that arrive at their dealerships, whether or not the customer has received a letter.

PLEASE NOTE:

Federal law requires dealers to complete this recall service before a new vehicle is delivered to the buyer or lessee. Violation of this requirement by a dealer could result in a civil penalty of up to \$21,000 per vehicle. Correct all vehicles in your new vehicle inventory before delivery.

ATTACHMENTS

Attachment I: Administrative Information
Attachment II: Labor Allowances and Parts Ordering Information
Attachment III: Technical Information – Bronco - Body Shop
Attachment IV: Technical Information – Bronco - Glass Company
Attachment V: Technical Information – Ranger - Body Shop
Attachment Vi: Technical Information – Ranger - Glass Company
Owner Notification Letters
Recall Reimbursement Plan

QUESTIONS & ASSISTANCE

For questions and assistance, contact the Special Service Support Center (SSSC) via the SSSC Web Contact Site. The SSSC Web Contact Site can be accessed through the Professional Technician System (PTS) website using the SSSC link listed at the bottom of the OASIS VIN report screen or listed under the SSSC tab.

Sincerely,

A handwritten signature in cursive script that reads "D. Johnson".

David J. Johnson

**NEW VEHICLE DEMONSTRATION / DELIVERY HOLD -
Compliance Recall 22C12**
Certain 2022 Model Year Bronco and Ranger Vehicles
Windshield Adhesion Repair

OASIS ACTIVATION

OASIS will be activated on June 28, 2022.

FSA VIN LISTS ACTIVATION

FSA VIN Lists will be available through <https://web.fsavinlists.dealerconnection.com> on June 28, 2022. Owner names and addresses will be available by July 29, 2022.

NOTE: Your FSA VIN Lists may contain owner names and addresses obtained from motor vehicle registration records. The use of such motor vehicle registration data for any purpose other than in connection with this recall is a violation of law in several states, provinces, and countries. Accordingly, you must limit the use of this listing to the follow-up necessary to complete this recall.

SOLD VEHICLES

- Ford has not issued instructions to stop selling/delivering or driving used vehicles under this compliance recall. Owners should contact their dealer for an appointment to have their vehicles remedied as soon as practicable. Owners can continue to safely drive their vehicles.
- Immediately contact any of your affected customers whose vehicles are not on your VIN list but are identified in OASIS. Give the customer a copy of the Owner Notification Letter (when available) and schedule a service date.
- Correct other affected vehicles identified in OASIS which are brought to your dealership.
- Dealers are to prioritize repairs of customer vehicles over repairs of new and used vehicle inventory.

STOCK VEHICLES

- Correct all affected units in your new vehicle inventory before delivery.
- Use OASIS to identify any affected vehicles in your used vehicle inventory.

DEALER-OPERATED RENTAL VEHICLES

The Fixing America's Surface Transportation (FAST) Act law effective June 2016 prohibits a rental company from selling, renting or leasing vehicles subject to a safety or compliance recall. Please consult your legal counsel for legal advice.

TITLE BRANDED / SALVAGED VEHICLES

Affected title branded and salvaged vehicles are eligible for this recall.

**NEW VEHICLE DEMONSTRATION / DELIVERY HOLD -
Compliance Recall 22C12**
Certain 2022 Model Year Bronco and Ranger Vehicles
Windshield Adhesion Repair

OWNER REFUNDS

- **This safety recall must still be performed, even if the owner has paid for a previous repair. Claiming a refund will not close the recall on the vehicle.**
- Ford Motor Company is offering a refund for owner-paid repairs covered by this recall if the repair was performed prior to the date indicated in the reimbursement plan, which is posted with this bulletin. Owners are directed to seek reimbursement through authorized dealers or, at their option, directly through Ford Motor Company at P.O. Box 6251, Dearborn, MI 48121-6251.
- Dealers are also pre-approved to refund owner-paid emergency repairs that were performed away from an authorized servicing dealer after the end date specified in the reimbursement plan. Non-covered repairs, or those judged by Ford to be excessive, will not be reimbursed.
- Refunds will only be provided for the cost associated with windshield repair due to inadequate urethane adhesion.

RENTAL VEHICLES

Dealers are pre-approved for up to 1 day for a rental vehicle. Follow Extended Service Plan (ESP) guidelines for dollar amounts. Rentals will only be reimbursed for the days the vehicle is at the dealership for part replacement. Prior approval for more than 1 rental days is required from the SSSC. Contact the SSSC via the SSSC Web Contact Site for consideration and approval if appropriate.

ADDITIONAL REPAIR (LABOR TIME AND/OR PARTS)

Additional repairs identified as necessary to complete the FSA should be managed as follows:

- For related damage and access time requirements, refer to the Warranty and Policy Manual / Section 6 – Ford & Lincoln Program Policies / General Information & Special Circumstances for FSA's / Related Damage.
- For vehicles within new vehicle bumper-to-bumper warranty coverage, no SSSC approval is required, although related damage must be on a separate repair line with the "Related Damage" radio button checked.
 - Ford vehicles – 3 years or 36,000 miles

For vehicles outside new vehicle bumper-to-bumper warranty coverage, submit an Approval Request to the SSSC Web Contact Site prior to completing the repair.

**NEW VEHICLE DEMONSTRATION / DELIVERY HOLD -
Compliance Recall 22C12**
Certain 2022 Model Year Bronco and Ranger Vehicles
Windshield Adhesion Repair

CLAIMS PREPARATION AND SUBMISSION

- **Claim Entry:** Enter claims using Dealer Management System (DMS) or One Warranty Solution (OWS) online.
 - When entering claims, select claim type 31: Field Service Action. The FSA number (22C12) is the sub code.
 - For additional claims preparation and submission information, refer to the Recall and Customer Satisfaction Program (CSP) Repairs in the OWS User Guide.
- **Related Damage/Additional labor and/or parts:** Must be claimed as Related Damage on a separate repair line from the FSA with same claim type and sub code as described in Claim Entry above.

IMPORTANT: Click the Related Damage Indicator radio button.
- **Rentals:** For rental vehicle claiming, follow Extended Service Plan (ESP) guidelines for dollar amounts. Enter the total amount of the rental expense under Miscellaneous Expense code RENTAL.
- **Bronco Sublet Glass Removal/Installation:** Sublet repairs to remove and install the windshield can be claimed instead of 22C12C. Sublet documentation must be retained. Submit on the same line as the repair.
 - Program Code: 22C12
 - Misc. Expense: FSAOSL
 - Misc. Expense: Claim up to \$350 (Bronco Only)
 - Claim difference is due to the labor time required for Bronco process.
- **Ranger Sublet Glass Removal/Installation:** Sublet repairs to remove and install the windshield can be claimed instead of 22C12D. Sublet documentation must be retained. Submit on the same line as the repair.
 - Program Code: 22C12
 - Misc. Expense: FSAOSL
 - Misc. Expense: Claim up to \$250 (Ranger Only)
- **Refunds:** Submit refunds on a separate repair line.
 - Program Code: 22C12
 - Misc. Expense: ADMIN
 - Misc. Expense: REFUND
 - Misc. Expense: 0.2 Hrs.
 - Multiple refunds should be submitted on one repair line and the invoice details for each repair should be detailed in the comments section of the claim.
- **Provision for Locally Obtained Supplies:** Cleaning supplies, consumables, and either Dow® or Sika® brand automotive glass bonding materials. Submit on the same line as the repair.
 - Program Code: 22C12
 - Misc. Expense: OTHER
 - Misc. Expense: Claim up to \$100

**NEW VEHICLE DEMONSTRATION / DELIVERY HOLD -
Compliance Recall 22C12**
Certain 2022 Model Year Bronco and Ranger Vehicles
Windshield Adhesion Repair

LABOR ALLOWANCES

Description	Labor Operation	Labor Time
Prepare windshield flange; protect vehicle, tape, scuff flange, clean flange, tape, and apply primers. (If Sublet: Claim by itself for windshield remove and install) (If Dealer only: Claim with C, D, or E)	22C12B	1.2 Hours
Bronco - Remove and install windshield Fiber Line method: includes time to remove/install wipers, mirror, visors and trim as well as cleaning current windshield, applying primer and urethane. (Can be used with B and E)	22C12C	2.0 Hours
Ranger - Remove and install windshield Cold Knife method: includes wiper and cowl removal, cleaning current windshield, applying primer and applying urethane. (Can be used with B and E)	22C12D	1.0 Hour
IPMA camera alignment	22C12E	0.3 Hours
Clean Vehicle	MT22C12	Up to 0.5 Hours

PARTS REQUIREMENTS / ORDERING INFORMATION

Part Number	Description	Order Quantity	Claim Quantity
Consumables Required for all Vehicles			
Obtain Locally	Masking Tape		Claim as MISC OTHER
	Glass Cleaner		
	Dow BETAPRIME 5504G / Sika Primer-207 or equivalent		
	SikaTack MACH 60 / SikaTack MACH 30 / Dow BETASEAL Express / Sika Tack ASAP Urethane Adhesive or equivalent		
	Roloc Disks or equivalent for urethane removal		
	Isopropyl Alcohol		
	Ford Approved Epoxy Based Primer		

**NEW VEHICLE DEMONSTRATION / DELIVERY HOLD -
Compliance Recall 22C12**
Certain 2022 Model Year Bronco and Ranger Vehicles
Windshield Adhesion Repair

PARTS REQUIREMENTS / ORDERING INFORMATION (continued)

Related Damage Only – Base Part Numbers		
-7803100-	Bronco - Windshield	As Needed VIN Specific – Only if breaks during removal procedure.
-2103100-	Ranger – Windshield	

Order your parts through normal order processing channels. To guarantee the shortest delivery time, an emergency order for parts must be placed.

Note: Less than 10% of the affected vehicle population is expected to require a windshield replacement.

DEALER PRICE

For latest prices, refer to DOES II.

PARTS RETENTION, RETURN, & SCRAPPING

Follow the provisions of the Warranty and Policy Manual, Section 1 - WARRANTY PARTS RETENTION AND RETURN POLICIES. If a replaced part receives a scrap disposition, the part must be scrapped in accordance with all applicable local, state and federal environmental protection and hazardous material regulations. Federal law prohibits selling motor vehicle parts or components that are under safety, compliance, or emissions recall.

EXCESS STOCK RETURN

Excess stock returned for credit must have been purchased from Ford Customer Service Division in accordance with Policy Procedure Bulletin 4000.

REPLACED FSA PARTS INSPECTION AND SIGN OFF

Effective March 1st 2021 all parts replaced as part of an FSA repair with a repair order open date of March 1st 2021 or later must be inspected and signed off on the repair order by a member of your dealers fixed operations management team or an employee the task has been delegated to. If the task is to be delegated to a non-management employee, the employee needs to be someone other than the technician who completed the repair and needs to understand the importance of completing this task consistently and accurately.

- All parts replaced as part of an FSA repair should be returned to the parts department following the Warranty Parts Retention and Return Policies.
- Inspect the replaced parts to verify the FSA repair was completed.
- If the FSA repair is found to be complete, the designated employee signs the repair order line or parts return stamp area (electronic or hand signed) for the FSA repair indicating the parts were inspected and validated to have been replaced.
- After the parts have been inspected, they should be handled based on the guidance in the parts status report in the Online Warranty System (Hold, Return, CORE, Scrap, etc.).

**NEW VEHICLE DEMONSTRATION / DELIVERY HOLD -
Compliance Recall 22C12**
Certain 2022 Model Year Bronco and Ranger Vehicles
Windshield Adhesion Repair

PARTS REQUIREMENTS / ORDERING INFORMATION (continued)

- This process is subject to review during warranty audits for FSA repairs with a repair order open date of March 1st 2021 or later. Any eligible FSA claims requiring parts replacement, found not to have been inspected and signed off during a warranty audit will be subject to chargeback and consideration for enrollment into the Dealer Incomplete Recall Repair Process.

Note: Other approvals (electronic or handwritten) for add-on repair lines, dealer owned vehicle repairs, and repeat repairs do not qualify as FSA parts inspection approvals. The post repair FSA parts inspection process (electronic or handwritten) is independent from other warranty approval requirements. The approval by the designated employee implies that the FSA parts were found to be replaced and must be able to be clearly identified on the Repair Order. If multiple FSA's require approval on a single Repair Order, each applicable occurrence will require individual post repair approval by the designated employee.

CERTAIN 2022 MODEL YEAR BRONCO AND RANGER VEHICLES — WINDSHIELD ADHESION REPAIR

SERVICE PROCEDURE – BODY SHOP INSTRUCTIONS

BRONCO VEHICLES

NOTE: These instructions are not intended to be followed from beginning to end. There are several locations where procedures must be completed by other groups before the procedure in these instructions can be resumed.

The instructions should be followed in this order.

1. Body Shop Part One – Prepare vehicle for repairs – Steps 1-2
2. Glass Company Part One – Remove windshield – Separate attachment
3. Body Shop Part Two – Improve flange adhesion – Steps 3-10 as required.
4. Glass Company Part Two – Install windshield – Separate attachment
5. Body Shop Part Three – Calibrate Image Processing Module A – Steps 11-13

BODY SHOP PART ONE

1. Remove the cowl panel grille. Please follow Workshop Manual (WSM) procedures in Section 501-02.
2. Remove the windshield header trim panel. Please follow WSM procedures in Section 501-05.

GLASS COMPANY PART ONE - SEPARATE ATTACHMENT

BODY SHOP PART TWO

3. Cover/protect the body and interior of the vehicle with a one-time use, disposable drop plastic.
4. Using a scraper, cut through the urethane bead vertically down to the painted surface to create a starting point.
 - Once reaching the painted surface, pry one side of the bead up with the scraper.
 - Using fingers, work to peel the urethane off the windshield body flange.



5. In areas where the urethane peeled up cleanly:
- Use 400-600 grit sandpaper or a fine Scotch-Brite pad.
 - Manually scuff the clear coat lightly until it displays a white haze.
 - Be sure to only abrade the flange.
 - See Figure 1.



FIGURE 1

6. In areas where the urethane did not peel up cleanly:
- Use a Scotch-Brite 3M Roloc disk to remove all remaining urethane from the flange.
 - Attempt to minimize abrasion to the painted surface.
 - See Figure 2.

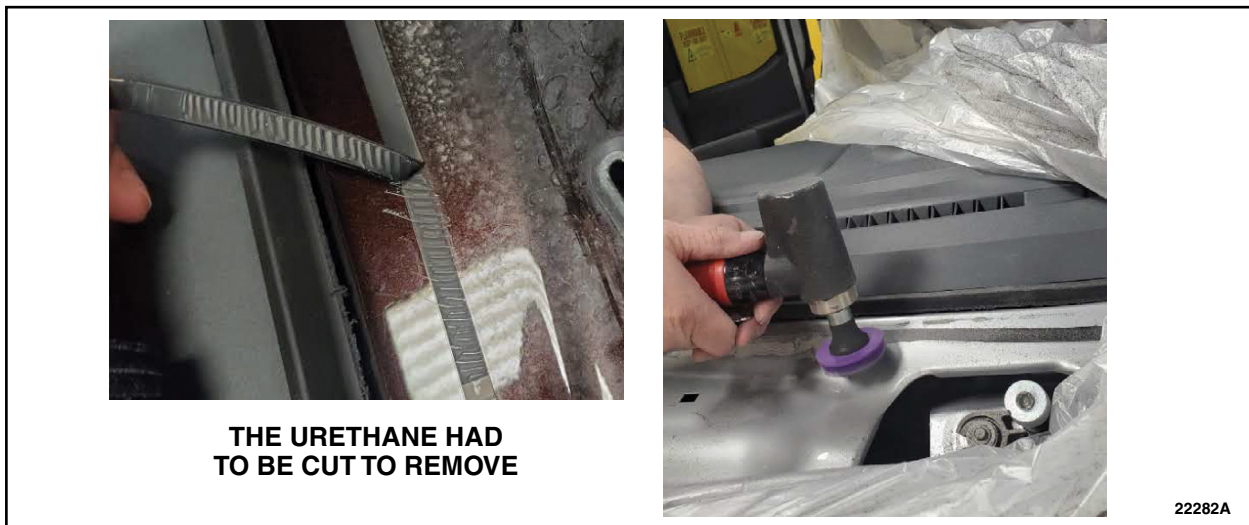

FIGURE 2



7. Clean off the entire windshield flange from all dirt and debris.
8. Using Isopropyl Alcohol and a lint-free cloth, clean off the flange surface. Allow one minute for the Isopropyl Alcohol to evaporate.
9. Apply tape to the edges of the windshield flange to protect the surface of the vehicle. See Figure 3.



FIGURE 3

10. Apply one coat of any Ford approved epoxy based repair primer to any spots where the roloc disk was used to grind off the urethane. See Figure 4.
 - Allow time for the primer to dry per the manufacturer's instructions.



FIGURE 4



GLASS COMPANY PART TWO - SEPARATE ATTACHMENT

BODY SHOP PART THREE

NOTICE: The door windows must be left open during the adhesive curing time.



WARNING: Do not drive vehicle until the urethane adhesive seal has cured. Follow urethane adhesive manufacturer's curing directions. Inadequate or incorrect curing of the urethane adhesive seal will adversely affect glass retention. Failure to follow these instructions may result in serious injury to vehicle occupant(s).

NOTE: Part Three may only be performed once the Glass Company repair procedures have been completed.

11. Remove the protective cover from the vehicle and clean off any dirt and debris.
12. Re-install all previously removed components by reversing steps 1-2.
13. After the windshield has been properly installed and the urethane has dried per the manufacturer's instructions, carry out the Image Processing Module A (IPMA) Camera alignment using a scan tool.



CERTAIN 2022 MODEL YEAR BRONCO AND RANGER VEHICLES — WINDSHIELD ADHESION REPAIR

SERVICE PROCEDURE – GLASS COMPANY INSTRUCTIONS

BRONCO VEHICLES

NOTE: These instructions are not intended to be followed from beginning to end. There are several locations where procedures must be completed by other groups before the procedure in these instructions can be resumed.

The instructions should be followed in this order.

1. Body Shop Part One – Prepare vehicle for repairs – Separate attachment
2. Glass Company Part One – Remove windshield – Steps 1-6 as required.
3. Body Shop Part Two – Improve Flange adhesion – Separate attachment
4. Glass Company Part Two – Install windshield – Steps 7-15
5. Body Shop Part Three – Calibrate Image Processing Module A – Separate attachment

BODY SHOP PART ONE - SEPARATE ATTACHMENT

GLASS COMPANY - PART ONE

1. Apply tape to the perimeter of the windshield to protect from paint damage. See Figure 1 as a locational reference.

NOTE: Tape off the roof panel near the centerline of the vehicle, where the roof extends forward. When using a fiber line to cut out the glass, the line will roll over the class A paint in the roof area, once tension is applied to it. If using a nylon style string, this will not damage the paint.



21363C

FIGURE 1



2. Remove the windshield using a fiber line cut out tool. See Figure 2.

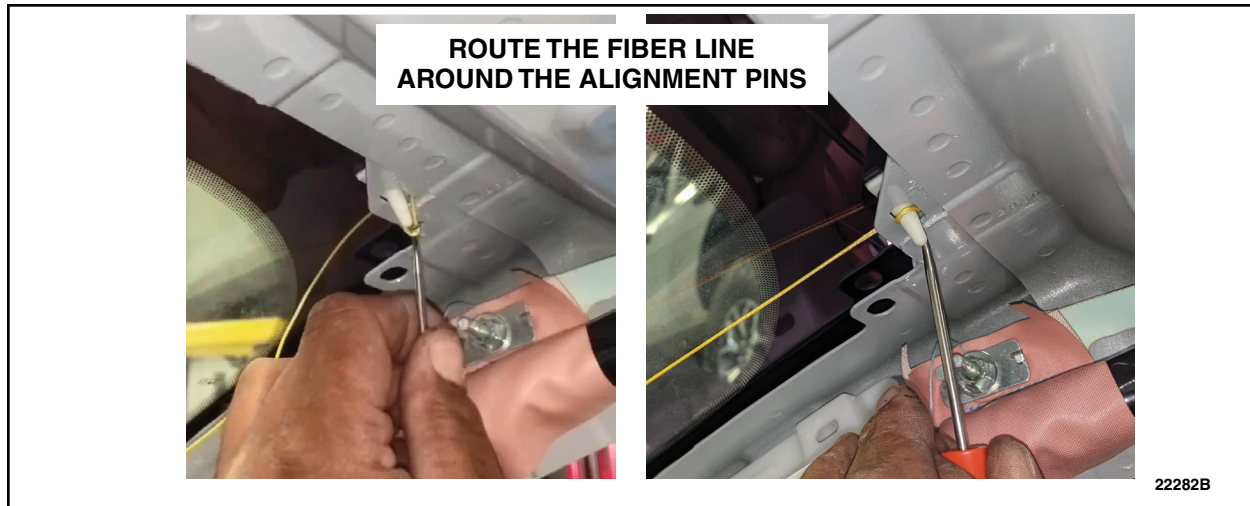

FIGURE 2

3. Remove the tape from the A-pillar and roof edge.

4. Inspect the windshield for possible damage. Is there any damage to the windshield?

Yes – Replace the windshield. Proceed to Step 5.

No – Re-install the original windshield. Proceed to Step 7 once Body Shop - Part Two has been completed.

NOTE: Damage to the alignment pins does not require windshield replacement.

5. Use glass cleaner to clean the surface of the new windshield to be installed.

6. Remove and transfer any necessary components onto the new windshield.

– Proceed to step 7 once Body Shop - Part Two has been completed.



BODY SHOP PART TWO - SEPARATE ATTACHMENT

GLASS COMPANY - PART TWO

NOTE: Part Two may only be performed once the Body Shop repair procedures to the window flange have been completed.

7. Shave down the urethane on the original windshield until there is 1mm remaining. See Figure 3.

NOTICE: New or reused fixed glass must be installed within 2 hours of cutting the urethane adhesive. Exposed cut surfaces of urethane become oxidized and inactive beyond 2 hours, reducing the effectiveness of the repair bond.



FIGURE 3

Material (Steps 8-11): Sika® Aktivator PRO / Dow® BETAPRIME™ 5504G / Sika® Primer-207

8. Apply two coats of urethane body flange primer according to the manufacturer's instructions to the entire windshield body flange at the urethane location.
 - Allow dry time between each coat applied.
9. Apply two coats of window primer at any location where the paint layers have been damaged to provide environmental protection.
 - Allow dry time between each coat applied.
10. If the windshield is being replaced, apply window primer according to the manufacturer's instructions to the new windshield.
 - Allow dry time per manufacturer's instructions.
11. If the original windshield is being reused, apply window primer according to the manufacturer's instructions to the fixed glass anywhere the urethane adhesive was completely removed.
 - Allow dry time per manufacturer's instructions.



12. Cut the urethane adhesive applicator tip to specification. See Figure 4.

Material: Sika® SikaTack® MACH 60 / Sika® SikaTack® MACH 30 / Dow® BETASEAL™ Express
Material: Sika Tack ASAP Urethane Adhesive

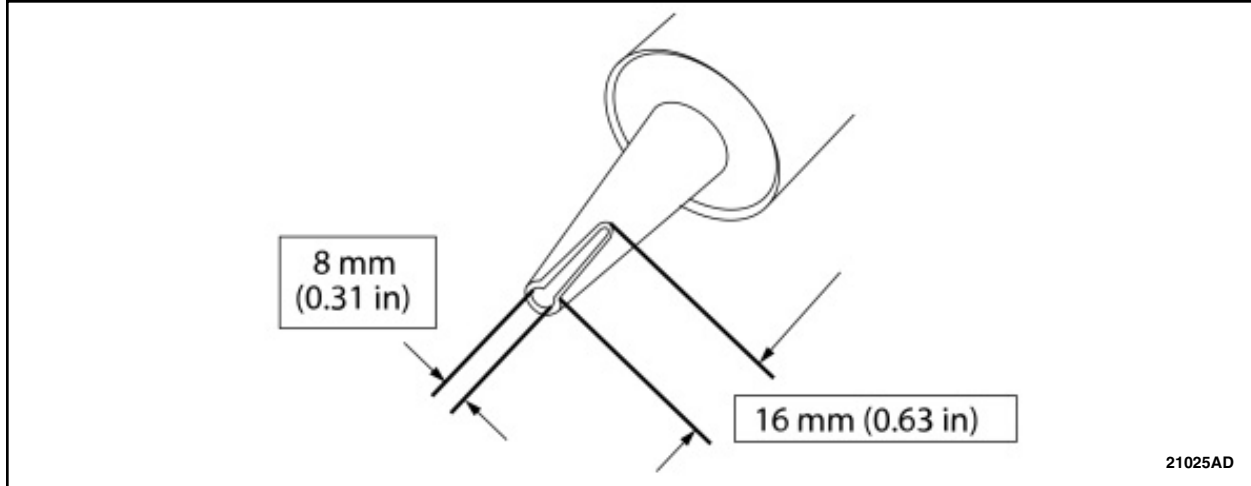

FIGURE 4

13. Apply a urethane adhesive bead. See Figure 5.

1. Start and end at the original overlap points to prevent air and water leaks.
2. Apply a urethane adhesive bead 14 mm (0.551 in) high and 8 mm (0.314 in) wide on top of the original urethane adhesive bead location.
3. Make sure there are no gaps in the bead.

NOTICE: Make sure the urethane bead is uniform to prevent air and water leaks.

NOTE: The fixed glass must be installed within 10 minutes of applying the urethane adhesive.

NOTE: Use a power caulk gun that applies the urethane adhesive with less effort and a continuous bead.

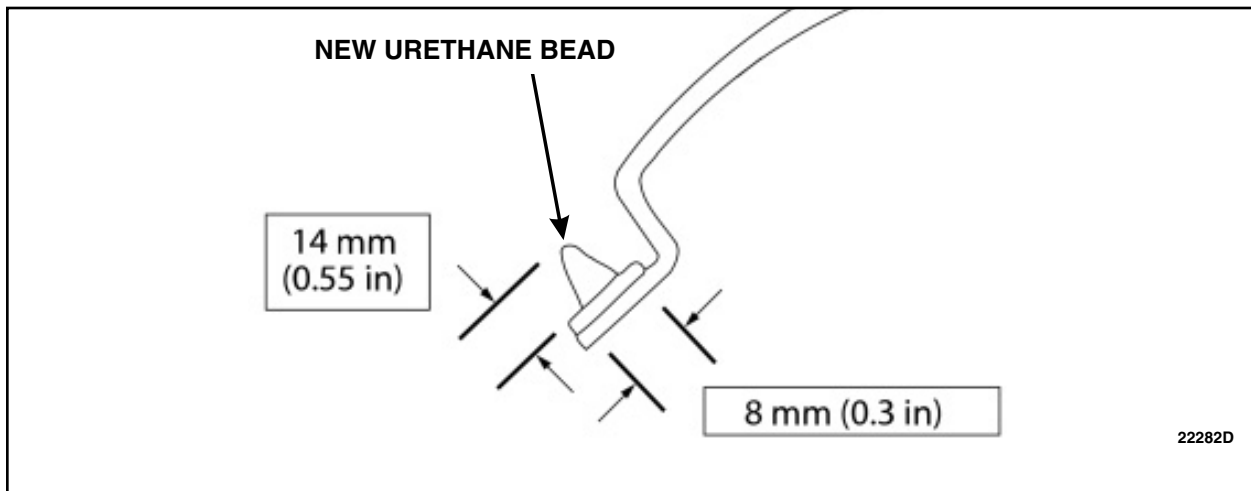

FIGURE 5



14. Open the vehicle windows to prevent the air pressure of closing doors from compromising the urethane adhesive bond.

NOTICE: The door windows must be left open during the adhesive curing time.

15. Install the fixed glass to the vehicle.
 1. Install the fixed glass, pressing firmly by hand to ensure a good bond.
 2. Secure the fixed glass in the correct position with tape until the urethane adhesive has cured.



WARNING: Do not drive vehicle until the urethane adhesive seal has cured. Follow urethane adhesive manufacturer's curing directions. Inadequate or incorrect curing of the urethane adhesive seal will adversely affect glass retention. Failure to follow these instructions may result in serious injury to vehicle occupant(s).

BODY SHOP PART THREE - SEPARATE ATTACHMENT



CERTAIN 2022 MODEL YEAR BRONCO AND RANGER VEHICLES — WINDSHIELD ADHESION REPAIR

SERVICE PROCEDURE – BODY SHOP INSTRUCTIONS

RANGER VEHICLES

NOTE: These instructions are not intended to be followed from beginning to end. There are several locations where procedures must be completed by other groups before the procedure in these instructions can be resumed.

The instructions should be followed in this order.

1. Body Shop Part One – Prepare vehicle for repairs – Step 1
2. Glass Company Part One – Remove windshield – Separate attachment
3. Body Shop Part Two – Improve flange adhesion – Steps 2-9 as required.
4. Glass Company Part Two – Install windshield – Separate attachment
5. Body Shop Part Three – Calibrate Image Processing Module A – Steps 10-12

BODY SHOP PART ONE

1. Remove the cowl panel grille. Please follow Workshop Manual (WSM) procedures in Section 501-02.

GLASS COMPANY PART ONE - SEPARATE ATTACHMENT

BODY SHOP PART TWO

2. Cover/protect the body and interior of the vehicle with a one-time use, disposable drop plastic.

NOTE: Ensure that the exposed headliner edge is fully covered.

3. Using a scraper, cut through the urethane bead vertically down to the painted surface to create a starting point.
 - Once reaching the painted surface, pry one side of the bead up with the scraper.
 - Using fingers, work to peel the urethane off the windshield body flange.



4. In areas where the urethane peeled up cleanly:
- Use 400-600 grit sandpaper or a fine Scotch-Brite pad.
 - Manually scuff the clear coat lightly until it displays a white haze.
 - Be sure to only abrade the flange.
 - See Figure 1.



FIGURE 1

5. In areas where the urethane did not peel up cleanly:
- Use a Scotch-Brite 3M Roloc disk to remove all remaining urethane from the flange.
 - Attempt to minimize abrasion to the painted surface.
 - See Figure 2.

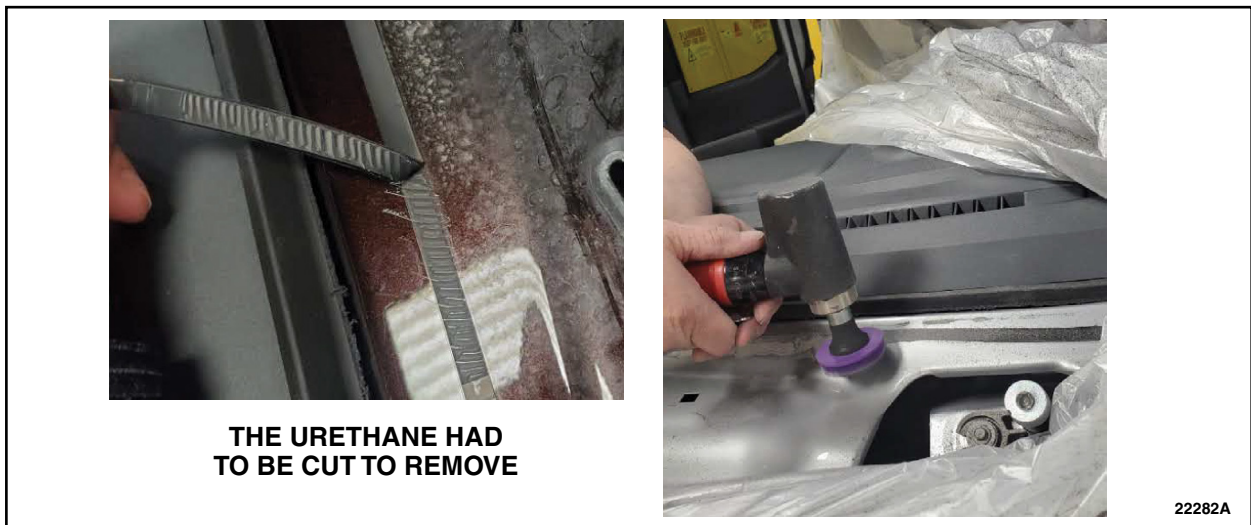

FIGURE 2



6. Clean off the entire windshield flange from all dirt and debris.
7. Using Isopropyl Alcohol and a lint-free cloth, clean off the flange surface. Allow one minute for the Isopropyl Alcohol to evaporate.
8. Apply tape to the edges of the windshield flange to protect the surface of the vehicle. See Figure 3.



FIGURE 3

9. Apply one coat of any Ford approved epoxy based repair primer to any spots where the roloc disk was used to grind off the urethane. See Figure 4.
 - Allow time for the primer to dry per the manufacturer's instructions.



FIGURE 4



GLASS COMPANY PART TWO - SEPARATE ATTACHMENT

BODY SHOP PART THREE

NOTICE: The door windows must be left open during the adhesive curing time.



WARNING: Do not drive vehicle until the urethane adhesive seal has cured. Follow urethane adhesive manufacturer's curing directions. Inadequate or incorrect curing of the urethane adhesive seal will adversely affect glass retention. Failure to follow these instructions may result in serious injury to vehicle occupant(s).

NOTE: Part Three may only be performed once the Glass Company repair procedures have been completed.

10. Remove the protective cover from the vehicle and clean off any dirt and debris.
11. Re-install all previously removed components by reversing step 1.
12. After the windshield has been properly installed and the urethane has dried per the manufacturer's instructions, carry out the Image Processing Module A (IPMA) Camera alignment using a scan tool.



CERTAIN 2022 MODEL YEAR BRONCO AND RANGER VEHICLES — WINDSHIELD ADHESION REPAIR

SERVICE PROCEDURE – GLASS COMPANY INSTRUCTIONS

RANGER VEHICLES

NOTE: These instructions are not intended to be followed from beginning to end. There are several locations where procedures must be completed by other groups before the procedure in these instructions can be resumed.

The instructions should be followed in this order.

1. Body Shop Part One – Prepare vehicle for repairs – Separate attachment
2. Glass Company Part One – Remove windshield – Steps 1-6 as required.
3. Body Shop Part Two – Improve Flange adhesion – Separate attachment
4. Glass Company Part Two – Install windshield – Steps 7-15
5. Body Shop Part Three – Calibrate Image Processing Module A – Separate attachment

BODY SHOP PART ONE - SEPARATE ATTACHMENT

GLASS COMPANY - PART ONE

1. Apply tape to the perimeter of the windshield to protect from paint damage. Multiple layers of tape may be required. See Figure 1 as a locational reference.



FIGURE 1



2. Remove the windshield using the cold knife method to cut the urethane from the outside of the vehicle provided the blade can reach the bead.

NOTE: It is suggested to use multiple blade lengths. See Figure 2.

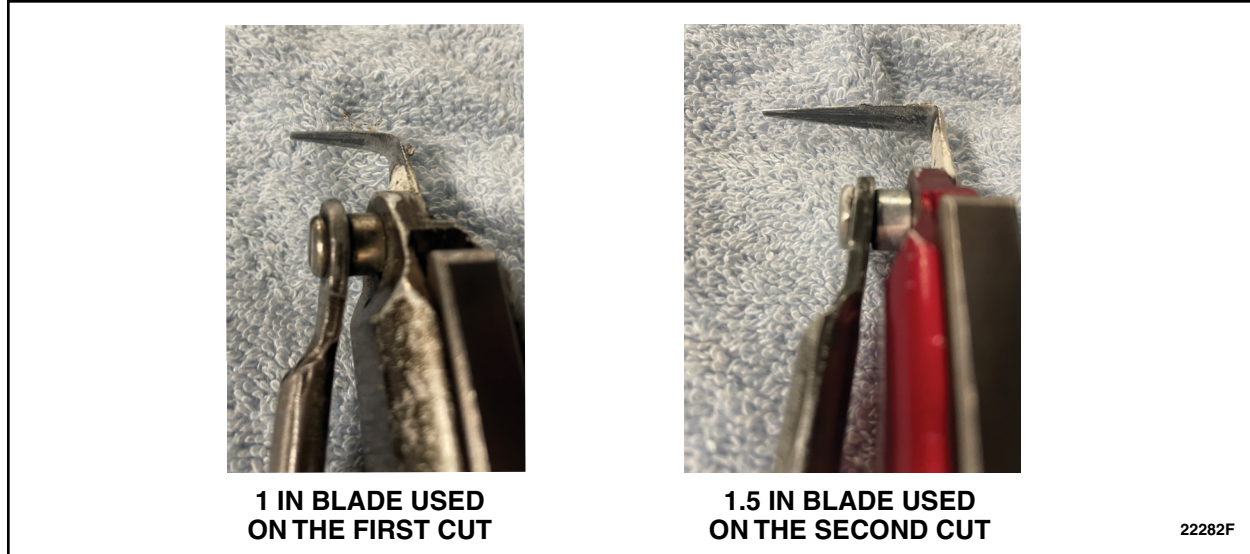

FIGURE 2

3. Remove the tape from the A-pillar and roof edge.
4. Inspect the windshield for possible damage. Is there any damage to the windshield?
 - Yes – Replace the windshield. Proceed to Step 5.
 - No – Re-install the original windshield. Proceed to Step 7 once Body Shop - Part Two has been completed.

NOTE: Damage to the alignment pins does not require windshield replacement.

5. Use glass cleaner to clean the surface of the new windshield to be installed.
6. Remove and transfer any necessary components onto the new windshield.
 - Proceed to step 7 once Body Shop - Part Two has been completed.



BODY SHOP PART TWO - SEPARATE ATTACHMENT

GLASS COMPANY - PART TWO

NOTE: Part Two may only be performed once the Body Shop repair procedures to the window flange have been completed.

7. Shave down the urethane on the original windshield until there is 1mm remaining. See Figure 3.

NOTICE: New or reused fixed glass must be installed within 2 hours of cutting the urethane adhesive. Exposed cut surfaces of urethane become oxidized and inactive beyond 2 hours, reducing the effectiveness of the repair bond.



FIGURE 3

Material (Steps 8-11): Sika® Aktivator PRO / Dow® BETAPRIME™ 5504G / Sika® Primer-207

8. Apply two coats of urethane body flange primer according to the manufacturer's instructions to the entire windshield body flange at the urethane location.
 - Allow dry time between each coat applied.
9. Apply two coats of window primer at any location where the paint layers have been damaged to provide environmental protection.
 - Allow dry time between each coat applied.
10. If the windshield is being replaced, apply window primer according to the manufacturer's instructions to the new windshield.
 - Allow dry time per manufacturer's instructions.
11. If the original windshield is being reused, apply window primer according to the manufacturer's instructions to the fixed glass anywhere the urethane adhesive was completely removed.
 - Allow dry time per manufacturer's instructions.



12. Cut the urethane adhesive applicator tip to specification. See Figure 4.

Material: Sika® SikaTack® MACH 60 / Sika® SikaTack® MACH 30 / Dow® BETASEAL™ Express
Material: Sika Tack ASAP Urethane Adhesive

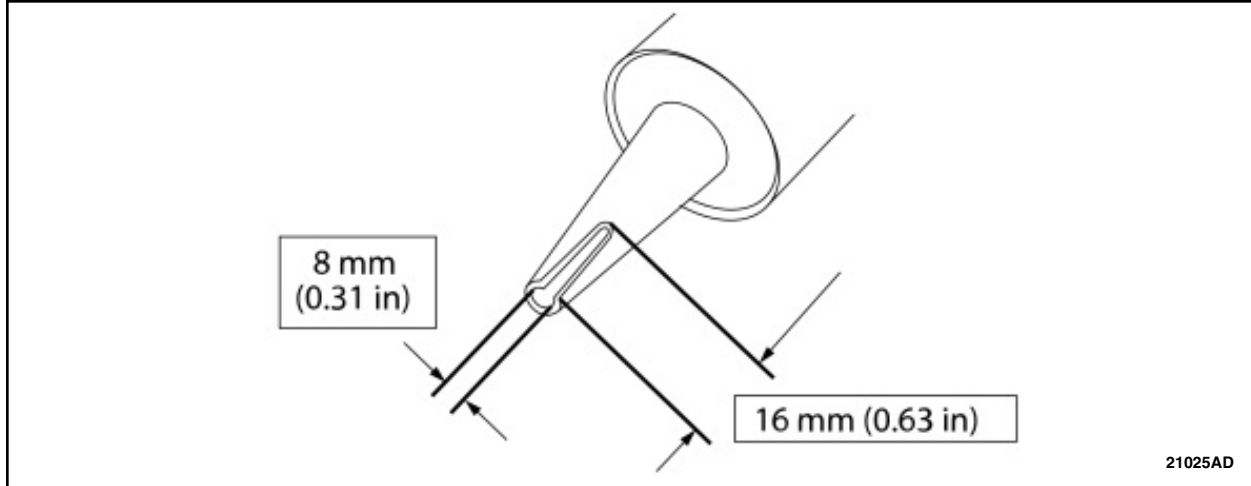

FIGURE 4

13. Apply a urethane adhesive bead. See Figure 5.

1. Start and end at the original overlap points to prevent air and water leaks.
2. Apply a urethane adhesive bead 14 mm (0.551 in) high and 8 mm (0.314 in) wide on top of the original urethane adhesive bead location.
3. Make sure there are no gaps in the bead.

NOTICE: Make sure the urethane bead is uniform to prevent air and water leaks.

NOTE: The fixed glass must be installed within 10 minutes of applying the urethane adhesive.

NOTE: Use a power caulk gun that applies the urethane adhesive with less effort and a continuous bead.

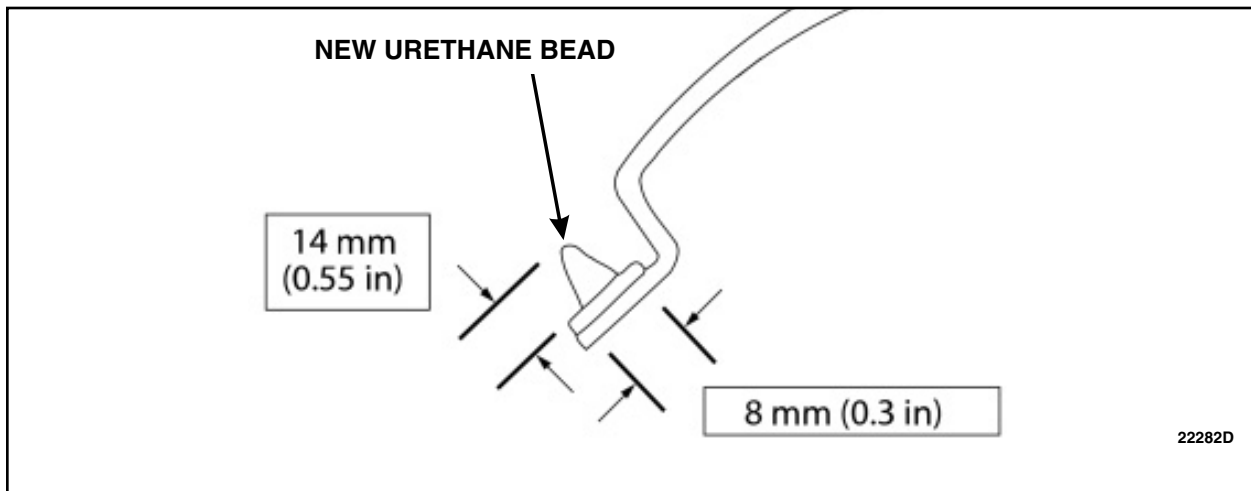

FIGURE 5



14. Open the vehicle windows to prevent the air pressure of closing doors from compromising the urethane adhesive bond.

NOTICE: The door windows must be left open during the adhesive curing time.

15. Install the fixed glass to the vehicle.
 1. Install the fixed glass, pressing firmly by hand to ensure a good bond.
 2. Secure the fixed glass in the correct position with tape until the urethane adhesive has cured.



WARNING: Do not drive vehicle until the urethane adhesive seal has cured. Follow urethane adhesive manufacturer's curing directions. Inadequate or incorrect curing of the urethane adhesive seal will adversely affect glass retention. Failure to follow these instructions may result in serious injury to vehicle occupant(s).

BODY SHOP PART THREE - SEPARATE ATTACHMENT



Ford Motor Company
Recall Reimbursement Plan for 22C12

Ford and Lincoln dealers are in the best position to quickly and efficiently process reimbursement requests. However, federal legislation requires all motor vehicle manufacturers to establish processes through which customers may seek recall reimbursement directly from the manufacturer or from the dealers.

*Regarding the specific reimbursement plan for Recall # 22C12, owners who have paid for service to remedy the defect or noncompliance must have had that service performed prior to **July 25, 2022**. After this date, if repairs related to this recall are performed by a non-Ford repair facility in an emergency situation, customers must submit any refund requests through their dealership. As required by this federal regulation, Ford Motor Company submitted the details of its latest General Recall Reimbursement Plan in a letter to the National Highway Traffic Safety Administration (NHTSA) in May 2021. The following is the text of that letter and the Plan:*

General Recall Reimbursement Plan
(As submitted to the NHTSA)

Pursuant to the requirements set forth in 49 CFR Part 573 and Part 577 of the Code of Federal Regulations, Ford Motor Company (Ford) is submitting required information pertaining to our general reimbursement plan for the cost of remedies paid for by vehicle owners before they are notified of a related safety recall.

Set forth below is Ford's general plan to reimburse owners and purchasers for costs incurred for remedies in advance of notification of potential safety-related defects or noncompliances pursuant to Part 573.6 (c)(8)(i). This plan has not changed since our February 20, 2019 submission.

Reimbursement Notification

Ford's notice to a vehicle owner in accordance with 49 CFR Part 577 will indicate that Ford is offering a refund if the owner paid to have service to remedy the defect or noncompliance prior to a specified ending date. In accordance with Part 573.13 (c)(2), this ending date will be defined as a minimum of ten calendar days after the date on which Ford mailed the last of its Part 577 notifications to owners, and will be indicated in the specific reimbursement plan available to owners for an individual recall. This notice will direct owners to seek eligible reimbursement through authorized dealers or, at their option, directly through Ford at the following address:

Ford Motor Company
P.O. Box 6251
Dearborn, MI 48121-6251

Ford notes that this rule allows for the identification of a beginning date for reimbursement eligibility. Under the rule, an owner who paid to remedy the defect or noncompliance prior to the identified beginning date would not be eligible for reimbursement. Ford generally has not established such a beginning date for reimbursement eligibility and does not presently anticipate changing this general policy. However, in any case where Ford determines a beginning date is appropriate, Ford will indicate that date in the owner notice. As permitted by 577.11(e), Ford may not include a reimbursement notification when all vehicles are well within the warranty period, subject to approval by the agency.

Costs to be Reimbursed

For vehicles, reimbursement will not be less than the lesser of:

- The amount paid by the owner for the remedy that specifically addressed and was reasonably necessary to correct the defect or noncompliance that is the subject of the recall, or
- The cost of parts for the remedy (to be no more than the manufacturer's list retail price for authorized part(s), plus associated labor at local labor rates, miscellaneous fees (such as disposal of waste) and taxes.

For replacement equipment, reimbursement will be the amount paid by the owner for the replacement item (limited by the amount of the retail list price of the defective or noncompliant item that was replaced, plus taxes, where the brand or model purchased by the owner was different than the brand or model that was the subject of the recall). If the item of motor vehicle equipment was repaired, the reimbursement provisions identified above for vehicles will apply.

Ford notes that costs incurred by the owner within the period during which Ford's original or extended warranty would have provided for a free repair of the problem will not be eligible for reimbursement, as provided by Part 573.13 (d)(1).

Entities Authorized to Provide Reimbursement

Ford will continue to use authorized dealers to reimburse owners under the specific reimbursement plans for a particular recall, and will encourage owners to pursue requests for reimbursement directly through dealers to expedite reimbursement. Ford will also provide a mailing address to which customers can, at their option, send requests for reimbursement directly to Ford, as previously noted. Requests for reimbursement sent directly to Ford may take up to 60 days to process. Whether the owner chooses to pursue reimbursement requests through a dealer or directly through Ford, the owner will be directed to submit the required documentation, upon which reimbursement eligibility will be determined.

Required Documentation

The reimbursement determination will depend upon the information provided by the customer. Consistent with Part 573.13 (d)(4) the following information must be submitted:

- Claimant name and address
- Vehicle make, model, and model year
- Vehicle identification number (VIN) and, for replacement equipment, a description of such equipment or, for tires, the model, size and TIN (DOT code)
- Identification of the recall number (either the Ford recall number or the NHTSA recall number)
- Identification of the owner of the recalled vehicle at the time that the pre-notification remedy was obtained
- An original receipt for the pre-notification remedy that includes a breakdown of the amount for parts, labor, other costs and taxes, including costs for the replacement item. Where the receipt covers work other than to address the recall or noncompliance, Ford may require the claimant to separately identify costs that are eligible for reimbursement.
- If the remedy was obtained during the warranty period, documentation indicating that the warranty was not honored or the warranty repair did not correct the problem related to the recall.

Failure to submit all of the above information may result in denial of the reimbursement request.

Additional Information

The Part 577 required owner notice will provide a toll-free telephone number through which specific information about the reimbursement plan can be requested from Ford. This general reimbursement plan will be incorporated into notifications pursuant to Part 573.6 by reference. Information specific to an individual recall also may be incorporated into the Part 573.6 notification.