

March 2026
FL938A-E
NHTSA #22V-405
Transport Canada #2022-300
REVISED NOTICE

Subject: Steering Gears

Models Affected: Specific model years 2022-2023 Freightliner Cascadia and Freightliner Custom Chassis MT45, and MT45G vehicles, manufactured June 9, 2021, through May 23, 2022, and equipped with an RH Sheppard steering gear.

General Information

Daimler Truck North America LLC (DTNA), on behalf of its Freightliner Trucks Division, and wholly owned subsidiary, Freightliner Custom Chassis Corporation, has decided that a defect that relates to motor vehicle safety exists on the vehicles mentioned above.

REVISION: The website link in the work instructions to check the steering gear has been updated.

On certain vehicles, an insufficient number of recirculating balls in the steering gear may cause the gear's internal parts to fracture, resulting in loss of steering, which could increase the risk of a crash.

The steering gear will be inspected and replaced as needed.

There are approximately 6,000 vehicles involved in this campaign.

Additional Repairs

Dealers must complete all outstanding Recall and Field Service campaigns prior to the sale or delivery of a vehicle. A Dealer will be liable for any progressive damage that results from its failure to complete campaigns before sale or delivery of a vehicle.

Owners may be liable for any progressive damage that results from failure to complete campaigns within a reasonable time after receiving notification.

Work Instructions

Please refer to the attached work instructions. Prior to performing the campaign, check the vehicle for a completion sticker (Form WAR260).

Replacement Parts

REVISION: The parts table has been updated to include the required hardware.

Replacement parts are now available and can be obtained by ordering the kit and/or part number(s) listed below from your facing Parts Distribution Center.

If our records show your dealership has ordered any vehicle(s) involved in campaign number FL938A-E, a list of the customers and vehicle identification numbers will be available on DTNAPortal. Please refer to this list when ordering parts for this recall.

Table 1 - Replacement Parts for FL938A-E

Campaign Number	Part Description	Part Number	Qty.
FL938A-C	STEERING GEAR	RHS MD83PB3Y	1 ea
FL938D-E	STEERING GEAR	RHS HD94PBE3Y	1 ea
FL938A-E	WASHER-FLAT,STEEL,HARDENED,3/4 IN	23-09114-004	6 ea
	SCREW-CAP,HEX,3/4-10,G	23-11757-350	3 ea
	NUT-HEX,LOCKING,3/4-10,GR8,ZN AL	23-13833-112	3 ea
	BLANK COMPLETION STICKER	WAR260	1 ea

Table 1

March 2026
FL938A-E
NHTSA #22V-405
Transport Canada #2022-300
REVISED NOTICE

Removed Parts

U.S. and Canadian Dealers, please follow Warranty Failed Parts Tracking shipping instructions for the disposition of all removed parts. Export distributors, please destroy removed parts unless otherwise advised.

Labor Allowance

Table 2 - Labor Allowance

Campaign Number	Procedure	Time Allowed (hours)	SRT Code	Corrective Action
FL938A,C	FCCC steering gear inspection	0.2	996-R162A	06-Inspect
FL938A-C	FCCC steering gear inspect and replace	1.4	996-R162B	12-Repair Recall/Campaign
FL938D	FTL steering gear inspect	0.2	996-R163A	06-Inspect
FL938D-E	FTL steering gear inspect and replace	2.5	996-R163B	12-Repair Recall/Campaign

Table 2

IMPORTANT: When the Recall has been completed, locate the base completion label in the appropriate location on the vehicle, and attach the red completion sticker provided in the recall kit (Form WAR260). If the vehicle does not have a base completion label, clean a spot on the appropriate location of the vehicle and first attach the base completion label (Form WAR259). If a recall kit is not required or there is no completion sticker in the kit, write the recall number on a blank sticker and attach it to the base completion label.

Claims for Credit

You will be reimbursed for your parts, labor, and handling (landed cost for Export Distributors) by submitting your claim through the Warranty system within 30 days of completing this campaign. Please reference the following information in OWL:

REVISION: The website link in the work instructions to check the steering gear has been updated.

- Claim type is **Recall Campaign**.
- In the Campaign field, enter the campaign number and appropriate condition code (e.g. **FL938-A, FL938-B, etc.**).
- In the Primary Failed Part Number field, enter **25-FL938-000**.
- In the claim story, enter the suspect steering gear serial number into the claim story.
- In the Parts field, enter the appropriate kit or part number(s) as shown in the Replacement Parts Table.
- In the Labor field, first enter the appropriate SRT from the Labor Allowance Table. Administrative time will be included automatically as SRT 939-6010A for 0.3 hours.
- The VMRS Component Code is **F99-999-005** and the Cause Code is **A1 - Campaign**.
- **U.S. and Canada -- Reimbursement for Prior Repairs.** When a customer asks about reimbursement, please do the following:
 - Accept the documentation of the previous repair.
 - Make a brief check of the customer’s paperwork to see if the repair may be eligible for reimbursement. (See the "Copy of Owner Letter" section of this bulletin for reimbursement guidelines.)
 - Submit an OWL Recall Pre-Approval Request for a decision.
 - Include the approved amount on your claim in the Other Charges section.
 - Attach the documentation to the pre-approval request.
 - If approved, submit a based on claim for the pre-approval.
 - Reimburse the customer the appropriate amount.

**March 2026
FL938A-E
NHTSA #22V-405
Transport Canada #2022-300
REVISED NOTICE**

IMPORTANT: OWL must be viewed prior to performing the recall to ensure the vehicle is involved and the campaign has not been previously completed. Also, check for a completion sticker prior to beginning work.

U.S. and Canadian dealers, contact the Warranty Campaigns Department via Web inquiry at DTNAPortal.com/WSC, if you have any questions or need additional information. Export distributors, submit a Web inquiry or contact your International Service Manager.

U.S. and Canadian Dealers: To return excess kit inventory related to this campaign, U.S. dealers must submit a Parts Authorization Return (PAR) to the Memphis PDC. Canadian dealers must submit a PAR to their facing PDC. All kits must be in resalable condition. PAR requests must include the original purchase invoice number. Export Distributors: Excess inventory is not returnable.

The letter notifying U.S. and Canadian vehicle owners is included for your reference.

Please note that the National Traffic and Motor Vehicle Safety Act, as amended (Title 49, United States Code, Chapter 301), requires the owner's vehicle(s) be corrected within a reasonable time after parts are available to you. The Act states that failure to repair a vehicle within 60 days after tender for repair shall be prima facie evidence of an unreasonable time. However, circumstances of a particular situation may reduce the 60 day period. Failure to repair a vehicle within a reasonable time can result in either the obligation to (a) replace the vehicle with an identical or reasonably equivalent vehicle, without charge, or (b) refund the purchase price in full, less a reasonable allowance for depreciation. The Act further prohibits dealers from selling a vehicle unless all outstanding recalls are performed. Any lessor is required to send a copy of the recall notification to the lessee within 10 days. Any subsequent stage manufacturer is required to forward this notice to its distributors and retail outlets within five working days.

March 2026
FL938A-E
NHTSA #22V-405
Transport Canada #2022-300
REVISED NOTICE

Copy of Notice to Owners

Subject: Steering Gears

For the Notice to U.S. Customers: This notice is sent to you in accordance with the National Traffic and Motor Vehicle Safety Act. **For the Notice to Canadian Customers:** This notice is sent to you in accordance with the requirements of the Motor Vehicle Safety Act. This is to inform you that your vehicle may contain a defect that could affect the safety of a person.

Daimler Trucks North America LLC (DTNA), on behalf of its Freightliner Trucks Division, and wholly owned subsidiary, Freightliner Custom Chassis Corporation, has decided that a defect which relates to motor vehicle safety exists on specific model years 2022-2023 Freightliner Cascadia, and Freightliner Custom Chassis MT45, and MT45G vehicles, manufactured June 9, 2021, through May 23, 2022, and equipped with an RH Sheppard steering gear.

On certain vehicles, an insufficient number of recirculating balls in the steering gear may cause the gear's internal parts to fracture, resulting in loss of steering, which could increase the risk of a crash.

The steering gear will be inspected and replaced as needed. Repairs will be performed by Daimler Truck North America authorized service facilities.

Please contact an authorized Daimler Truck North America dealer to arrange to have the Recall performed and to ensure that parts are available at the dealership. The Recall will take approximately a half hour to three hours depending on the repair and will be performed at no charge to you. To locate an authorized dealer, search online at <https://northamerica.daimlertruck.com/contact-us/>. Scroll down to "Locate a Dealer," and select the appropriate brand. You may also confirm your vehicle's involvement in this recall at this URL: <https://dtna-dlinfo.prd.freightliner.com:48518/VinLookup/vin-module/getVinLookupPage>.

You may be liable for any progressive damage that results from your failure to complete the Recall within a reasonable time after receiving notification.

If you do not own the vehicle that corresponds to the identification number(s) which appears on the Recall Notification, please return the notification to the Warranty Campaigns Department in the postage-paid envelope with any information you can furnish that will assist us in locating the present owner. If you have leased this vehicle, Federal law requires that you forward this notice to the lessee within 10 days. If you are a subsequent stage manufacturer, Federal law requires that you forward this notice to your distributors and retail outlets within five working days. If you have paid to have this recall condition corrected prior to this notice, you may be eligible to receive reimbursement. Please see the reverse side of this notice for details.

If you have questions about this Recall, please contact the Warranty Campaigns Department at (800) 547-0712, 7:00 a.m. to 4:00 p.m. Pacific Time, Monday through Friday, e-mail address dtna.warranty.campaigns@daimlertruck.com. **For the Notice to U.S. Customers:** If you are not able to have the defect remedied without charge and within a reasonable time, you may wish to submit a complaint to the Administrator, National Highway Traffic Safety Administration, 1200 New Jersey Avenue, SE., Washington, DC 20590; or call the Vehicle Safety Hotline at (888) 327-4236 (TTY: 800-424-9153); or to <http://www.nhtsa.gov>. **For the Notice to Canadian Customers:** If you wish to submit a complaint about this recall, you can contact Transport Canada road safety, 80 rue Noel, Gatineau, Quebec J8Z 0A1 or call (800) 333-0510.

We regret any inconvenience this action may cause but feel certain you understand our interest in motor vehicle safety.

WARRANTY CAMPAIGNS DEPARTMENT

Enclosure

March 2026
FL938A-E
NHTSA #22V-405
Transport Canada #2022-300
REVISED NOTICE

Reimbursement to Customers for Repairs Performed Prior to Recall

If you have already **paid** to have this recall condition corrected you may be eligible to receive reimbursement.

Requests for reimbursement may include parts and labor. Reimbursement may be limited to the amount the repair would have cost if completed by an authorized Daimler Truck North America LLC dealer. The following documentation must be presented to your dealer for consideration for reimbursement.

Please provide original or clear copies of all receipts, invoices, and repair orders that show:

- The name and address of the person who paid for the repair
- The Vehicle Identification Number (VIN) of the vehicle that was repaired
- What problem occurred, what repair was done, when the repair was done
- Who repaired the vehicle
- The total cost of the repair expense that is being claimed
- Proof of payment for the repair (such as the front and back of a cancelled check or a credit card receipt)

Reimbursement will be made by check from your Daimler Truck North America LLC dealer.

Please speak with your Daimler Truck North America LLC authorized dealer concerning this matter.

March 2026
FL938A-E
NHTSA #22V-405
Transport Canada #2022-300
REVISED NOTICE

Work Instructions

Subject: Steering Gears

Models Affected: Specific model years 2022-2023 Freightliner Cascadia and Freightliner Custom Chassis MT45, and MT45G vehicles, manufactured June 9, 2021, through May 23, 2022, and equipped with an RH Sheppard steering gear.

REVISION: The website link in the work instructions to check the steering gear has been updated.

Steering Gear Inspection and Classification

1. Check the base label (Form WAR259) for a completion sticker for FL938 (Form WAR260) indicating this work has been done. The base label is usually located on the passenger door about 12 inches (30 cm) below the door latch. If a sticker is present, no work is needed. If there is no sticker, proceed with the next step.
2. Park the vehicle on a level surface, shut down the engine, and set the parking brake. Chock the tires.
3. Locate the steering gear on the front left frame rail of the vehicle.
4. Locate the serial number on the steering gear. See **Fig. 1**.

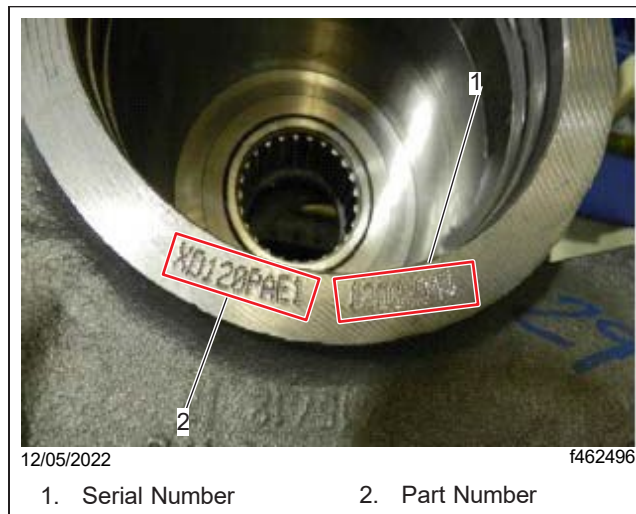

Fig. 1, Steering Gear Identification

5. To determine if the steering gear needs replacement, go to <https://rhsheppard.com/service-and-support-2/product-action-center/>.

**March 2026
FL938A-E
NHTSA #22V-405
Transport Canada #2022-300
REVISED NOTICE**

6. Select the 'Select Vehicle Make' option. From the dropdown menu, select 'FREIGHTLINER, DAIMLER TRUCK.' See [Fig. 2](#).
7. Enter the steering gear serial number, noted in step 4, in the designated field. Select 'Search.' See [Fig. 2](#).

Please select your vehicle make and enter the full 8-character serial number before the dash (-) as shown below without any spaces or the "-C" at the end.

SERIAL NUMBER EXAMPLE:

21E07957-C

21 represents the year the steering gear was built.

E indicates the month the steering gear was built (A = January, B = February, C = March, D = April, E = May, etc.).

07957 is the sequential serial number for gears built that month.

-C indicates the steering gear has a snap ring style sector cover with a retainer clip.

B

C

Select Vehicle Make

Please enter gear serial number

Search

Reset

Select Vehicle Make

ACTION TRUCK PARTS

AM GENERAL

AUTOCAR

B & J TECH

CAPACITY OF TEXAS

CARGOTEC

CRANE CARRIER

ELDORADO

EMERGENCY ONE

ENGINE & ACCESSORY

FERRARA FIRE APPARATUS

FORETRAVEI

FREIGHTLINER, DAIMLER TRUCK

FWD

GLOBAL SWEEPING SOL

GRANDE WEST

HMF

THE INPUT OF ACCURATE DATA AND ASSUMES ALL RISKS ASSOCIATED WITH FAILURE TO DO SO.

Information

INITIATES A VOLUNTARY SHEPPARD™ STEERING GEAR RECALL ACTION

Safety and customer satisfaction are top priorities at R.H. Sheppard Co., Inc. (Sheppard). The company has identified rd™ steering gears – models HD94E™, HD94P™, M80P™, M83P™, M90P™, M100P™, M110P™, MD83P™, SD110P™, between June 1, 2021, and February 1, 2022, inclusive. This action does not affect Sheppard remanufactured steering gear manufactured prior to or after the stated dates.

11/29/2022 f462487

A. Select 'FREIGHTLINER, DAIMLER TRUCK.'

B. Enter the gear serial number.

C. Select 'Search.'

Fig. 2, Sheppard Steering Gear Classification Tool

March 2026
FL938A-E
NHTSA #22V-405
Transport Canada #2022-300
REVISED NOTICE

8. Check for the result received, and note the serial number for claim submission.

Good, as shown in **Fig. 3** → No further action is required. Clean a spot on the base label (Form WAR259) and attach a campaign completion sticker for FL938 (Form WAR260), indicating this work has been completed.

Suspect, as shown in **Fig. 4** → Replace the steering gear. Go to **Steering Gear Replacement** procedure.

The screenshot shows the Sheppard Steering Gear Classification Tool interface. At the top left is the Sheppard logo. Below it is a title bar for the tool. A warning message reads: "STOP !! - READ THIS BEFORE BEGINNING. Sheppard remanufactured steering gears, slave gears ARE NOT affected by this recall. Refer to the Identification Guideline for identification of affected steering gears as well as interpretation of the serial and part number. Please select your vehicle make and enter the full 8-character serial number before the dash (-) as shown below without any spaces or the "-C" at the end." Below this is a "SERIAL NUMBER EXAMPLE:" section with a diagram of the serial number "21E07957-C". The diagram explains: "21" is the year, "E" is the month, "07957" is the sequential number, and "-C" indicates a snap ring style sector cover. Below the diagram is a search form with a dropdown menu set to "FREIGHTLINER, DAIMLER TRUCK", a search input field, and "Search" and "Reset" buttons. A disclaimer states: "USER IS SOLELY RESPONSIBLE FOR THE INPUT OF ACCURATE DATA AND ASSUMES ALL RISKS ASSOCIATED WITH FAILURE TO DO SO." The "Result" section shows a green box with the text: "Steering Gear serial number : Good" and "Vehicle can be returned to service with no further remedy action", with a black arrow pointing to the right. The "Details" section shows: "Serial Number: 21105802" and "Vehicle Make (OEM) or AM: FREIGHTLINER, DAIMLER TRUCK". At the bottom left is the date "11/29/2022" and at the bottom right is the ID "f462488".

Fig. 3, Result Received: Good

March 2026
FL938A-E
NHTSA #22V-405
Transport Canada #2022-300
REVISED NOTICE

SHEPPARD

Sheppard Steering Gear Classification Tool

STOP !! - READ THIS BEFORE BEGINNING.

Sheppard **remanufactured steering gears, slave gears ARE NOT** affected by this recall.

Refer to the [Identification Guideline](#) for identification of affected steering gears as well as interpretation of the serial and part number.

Please select your vehicle make and enter the full 8-character serial number before the dash (-) as shown below without any spaces or the "-C" at the end.

SERIAL NUMBER EXAMPLE:

21E07957-C

- 21 represents the year the steering gear was built.
- E indicates the month the steering gear was built (A = January, B = February, C = March, D = April, E = May, etc.).
- 07957 is the sequential serial number for gears built that month.
- C indicates the steering gear has a snap ring style sector cover with a retainer clip.

FREIGHTLINER, DAIMLER TRUCK

USER IS SOLELY RESPONSIBLE FOR THE INPUT OF ACCURATE DATA AND ASSUMES ALL RISKS ASSOCIATED WITH FAILURE TO DO SO.

Result

Steering Gear serial number : Suspect
Remove and replace gear per the vehicle manufacturer's instructions

Details

Serial Number: 21h01741
Vehicle Make (OEM) or AM: FREIGHTLINER, DAIMLER TRUCK

11/29/2022 f462489

Fig. 4, Result Received: Suspect

Steering Gear Replacement

1. What is the make of the vehicle?

Freightliner → For instructions to replace the steering gear, see **Section 46.04, Subject 100** of the *New Cascadia workshop manual*. Then go to step 33.

FCCC → Follow the steps 2 through 33 to replace the steering gear.

MArch 2026
FL938A-E
NHTSA #22V-405
Transport Canada #2022-300
REVISED NOTICE

NOTE: Ensure the wheels are facing straight ahead throughout the steering gear replacement procedure.

2. Remove the cotter pin from the castle nut at the steering arm-to-draglink connection. See [Fig. 5](#).

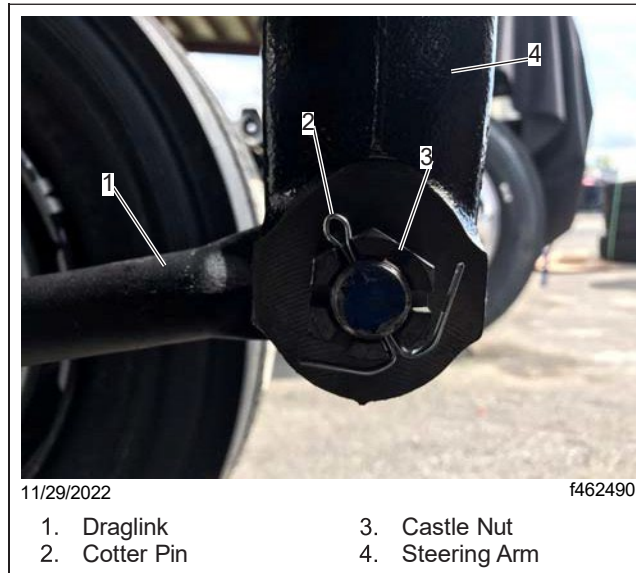

Fig. 5, Cotter Pin Removal

3. Use a 1-1/8 inch socket to remove the castle nut. Retain the castle nut for installation in the later step. Remove the draglink from the pitman arm.
4. At the pitman arm-to-steering gear connection, use a punch to bend the retaining tabs out of the pitman arm retainer. See [Fig. 6](#).

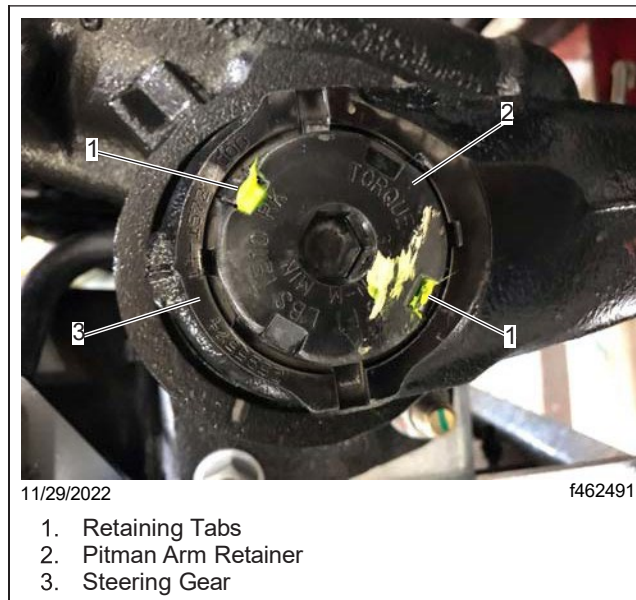

Fig. 6, Bending the Pitman Arm Retaining Tabs

March 2026
FL938A-E
NHTSA #22V-405
Transport Canada #2022-300
REVISED NOTICE

IMPORTANT: To avoid difficulty in removing the pitman arm, ensure to lubricate the face of the retainer.

5. Lubricate the face of the retainer with a clean chassis lube.
6. Disconnect the pitman arm from the steering gear.
 - 6.1 Slide the pitman arm puller over the pitman arm. Align the hole in the puller with the Allen socket in the retainer.
 - 6.2 Insert the Allen drive socket through the puller and into the retainer socket. Use an impact wrench to back off the retainer. The retainer will act as a jackscrew to disconnect the pitman arm from the steering gear.
7. Use a 5/8-inch wrench and a 11/16-inch socket to remove the pinch bolt that attach the steering linkage to the top of the steering gear. Discard the fasteners. See [Fig. 7](#).

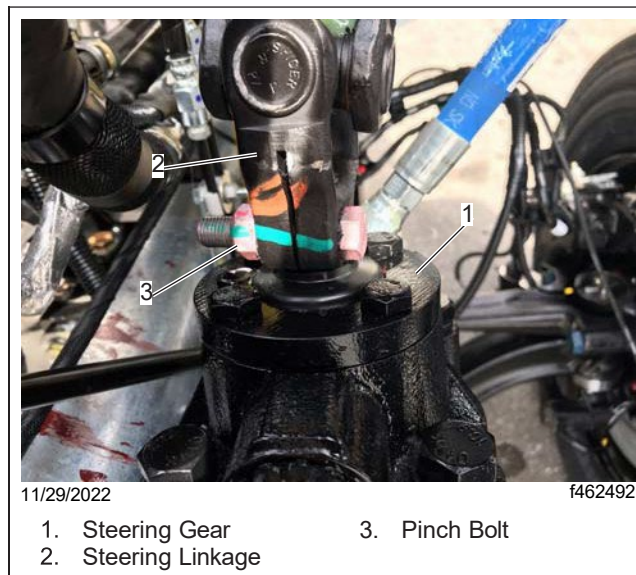

Fig. 7, Pinch Bolt Removal

8. Remove the steering linkage from the gear by sliding the shaft upwards, away from the steering gear.

March 2026
FL938A-E
NHTSA #22V-405
Transport Canada #2022-300
REVISED NOTICE

9. Use a 7/8-inch wrench to loosen and remove the hydraulic lines from the fittings on the rearward-facing side of the steering gear. See **Fig. 8**.



Fig. 8, Hydraulic Lines Removal

10. Use a 7/8-inch wrench to remove the fittings from the steering gear. Retain the fittings for installing on the replacement gear.

March 2026
FL938A-E
NHTSA #22V-405
Transport Canada #2022-300
REVISED NOTICE

11. Use a 1-1/8 inch socket and wrench to remove the three bolts and washers that attach the steering gear to the rail. Discard the fasteners. See [Fig. 9](#).
12. Remove the steering gear.

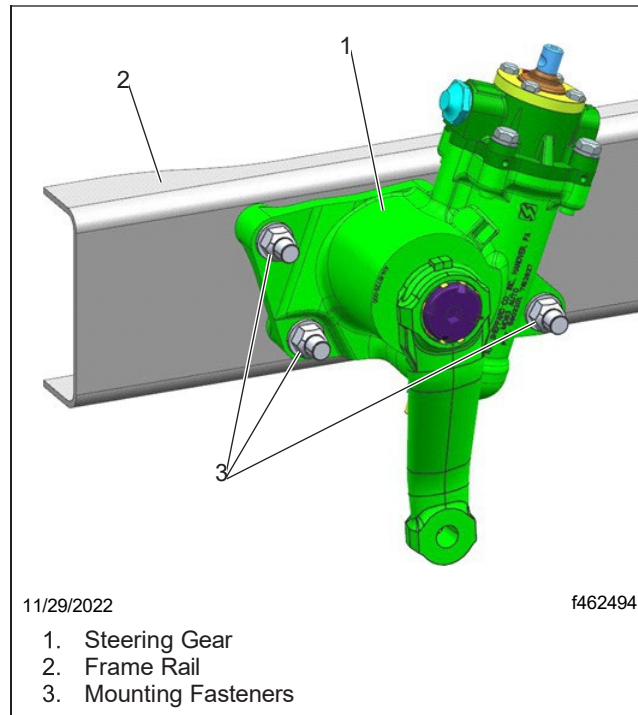

Fig. 9, Steering Gear Removal

NOTICE

The head side of bolts needs to be inboard, inside the rail flange.

13. Install the washer (23-09114-004) on the new bolt (23-11757-350), then install the bolts into the three holes in the rail.
14. Install the new steering gear (RHS MD83PB3Y) on the bolts in the rail. Install the washer (23-09114-004) first, and then install the nut (23-13833-112). Tighten the fasteners hand tight.
15. Use a 1-1/8 inch socket and wrench to tighten the fasteners that attach the steering gear to the rail. Tighten the fasteners 221 lbf·ft (300 N·m).
16. Install the hydraulic hose fittings in the gear, oriented as shown in [Fig. 8](#). Tighten the hose fittings 45 lbf·ft (61 N·m).
17. Install the hose on the fittings, and tighten them hand tight.
18. While holding the small part of the fittings using a 3/4-inch wrench, use a 7/8-inch wrench to tighten the hose fittings. Tighten the hose fittings 45 lbf·ft (61 N·m).

March 2026
FL938A-E
NHTSA #22V-405
Transport Canada #2022-300
REVISED NOTICE

19. Make sure the bolt hole in the steering linkage, and the groove on the steering gear input shaft align properly. Install the steering linkage on top of the gear. See [Fig. 10](#).

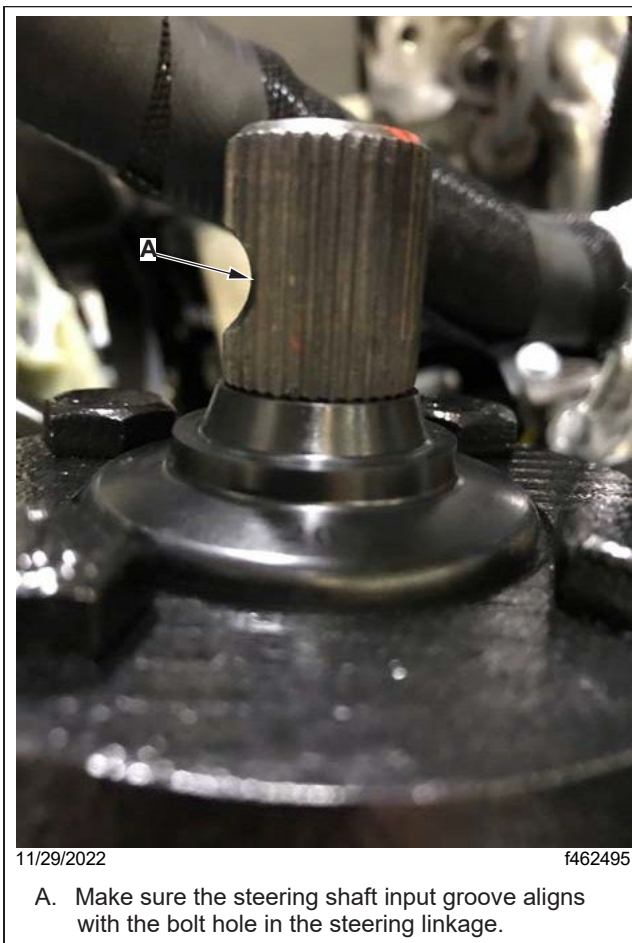

Fig. 10, Steering Linkage Installation

20. Install the new bolt (14-18773-001) and the nut (14-18774-000) on the steering shaft. Tighten the nut 43 lbf·ft (58 N·m).

March 2026
FL938A-E
NHTSA #22V-405
Transport Canada #2022-300
REVISED NOTICE

21. Align the timing marks on the pitman arm with the timing marks on the sector shaft, then install the pitman arm on the sector shaft. The timing marks will appear as shown in [Fig. 11](#) and [Fig. 12](#).

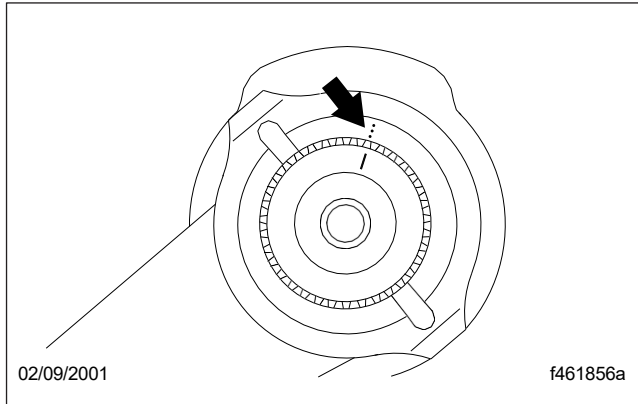

Fig. 11, Aligning the Timing Marks

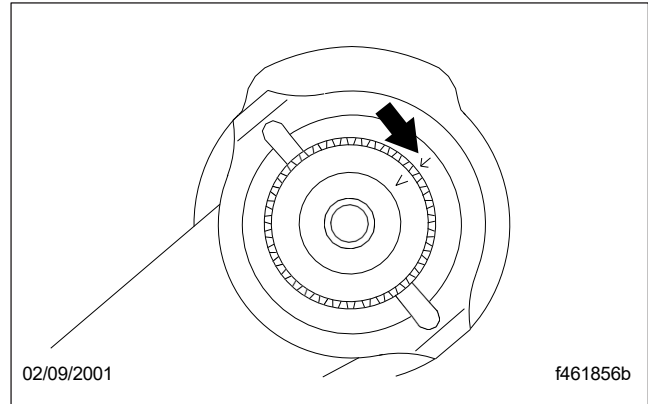

Fig. 12, Aligning the Timing Marks

22. Install the pitman arm retainer on the sector shaft. Make sure to align the tabs in the notches of the pitman arm.
23. Coat the threads of the retainer with an antiseize compound. A coating of antiseize should be applied to both sides of the friction washer if a new retainer is being used.
24. Tighten the retainer 225 lbf·ft (305 N·m).
- NOTE: Do not back off the torque value to align the tabs. If the pitman arm is not tightened to the specified torque, it can come loose.
25. Continue tightening the retainer past the specified value until two of the notches in the retainer align with the tabs of the washer.
26. Use a punch and hammer to bed the retaining tabs of the washer into the notches on the retainer. Apply the torque seal.
27. Install the draglink on the pitman arm, then install the castle nut removed in step 2. Tighten the castle nut hand tight.
28. Tighten the castle nut 70 lbf·ft (95 N·m).
29. If the cotter pin hole is not accessible, advance the castle nut to the nearest slot, and install the cotter pin. Bend the split side of cotter pin around the nut as shown in [Fig. 5](#).
30. Verify no leaks are present, and fill the power steering reservoir with fluid (48-02182-001).
31. Turn the steering wheel to extremities in clockwise and counter clockwise directions to check the clearance and function of steering components.
32. Road test the vehicle to ensure proper steering functionality.
33. Clean a spot on the base label (Form WAR259) and attach a campaign completion sticker for FL938 (Form WAR260), indicating this work has been completed.