

21PBK - Model 520 Dual Steer Quick Release – NHTSA ID: 21V720

 [Edit](#)  [Clone](#)

Number

21PBK

Supplier

Peterbilt

Description

Model 520 Dual Steer Quick Release – NHTSA ID: 21V720

Date

9/23/2021

What's New

Safety Recall – Certain Model 520 trucks may have been built without a quick release (QR) valve. The absence of this valve could affect rear brake timing on certain vehicles equipped with a tri-drive or liftable tag axle and Dual Seated or Right Hand Stand-Up steering configurations. Vehicles will be inspected and, if necessary, a QR valve will be installed.

Introduction

Peterbilt has decided that certain Model 520 trucks built from 11/04/2019 through 3/30/2021 may have been built without a quick release valve. The absence of this valve could affect rear brake timing on certain vehicles equipped with a tri-drive or liftable tag axle and Dual Seated or Right Hand Stand-Up steering configurations.

Resolution

Safety Recall

Service all affected chassis that enter your dealership, even if the customer has no issue with the chassis.

1. Review the attached chassis list for your dealer code and schedule your customer(s) for service if their chassis is on the list.
2. If you are not using Service Management to start repair orders, review SIR for "Complete" or "In Process" next to the "21PBK" campaign code prior to performing this repair.
3. Follow the procedures below to inspect the brake plumbing and, if necessary, install the quick release valve.

Federal Law

It is a violation of Federal law for a dealer to sell or lease new vehicles covered by this recall until the defect or noncompliance has been corrected.

Warranty

There is no time or mileage limit for this recall. Peterbilt will pay for parts at dealer net plus applicable mark up and labor:

- 0.3 hours to inspect the brake plumbing to see if the quick release valve is installed. File Quick Claim 21PBKA.
 - This labor is for inspection only. It is not applicable for trucks that require the quick release valve installation.
- 0.4 hours to install the quick release valve and complete the necessary plumbing for Dual Seated Drive configuration. File Quick Claim 21PBKB. This includes the inspection of the brake plumbing for the presence of the quick release valve.
- 0.4 hours to install the quick release valve and complete the necessary plumbing for Right Hand Stand-Up configuration. File Quick Claim 21PBKC. This includes the inspection of the brake plumbing for the presence of the quick release valve.
- File an additional claim for extraordinary circumstances, referencing 21PBK. A quick claim for standard labor must be filed first.

Take-off parts disposition: Destroy parts 30 days after the claim has been paid.

PRWS CLAIM CODING

Campaign Code:	21PBK	Campaign Type	Safety Recall
Claim Category:	Truck	Repair Type	Proactive
Customer Concern Code	029	Causal Code	A1
Corrective Action Code	12	Responsibility Code:	Camp
Failure Location	013-010-008	Causal Part	288251BXW
Supplier Code	N/A	SRT Code	<p>013-183</p> <p>0.3 hours to inspect the brake plumbing for the quick release valve.</p> <p>013-184</p> <p>0.4 hours to install and plumb the quick release valve – includes inspection for the presence of the valve.</p>

CLAIM CODING			
Failure Location:	013-010-008	Work Accomplished:	69
Failure Type:	705	Responsibility Code:	09
SRT Code:	<p>013-183 0.3 hours to inspect the brake plumbing for the quick release valve.</p> <p>013-184 0.4 hours to install and plumb the quick release valve – includes inspection for the presence of the valve.</p>	Claim Type:	C

Procedure

1. Inspect the truck to see if the Quick Release (QR) valve is installed. If not installed as shown below, tilt the cab forward for access and bolt the QR valve to the washer bottle housing.

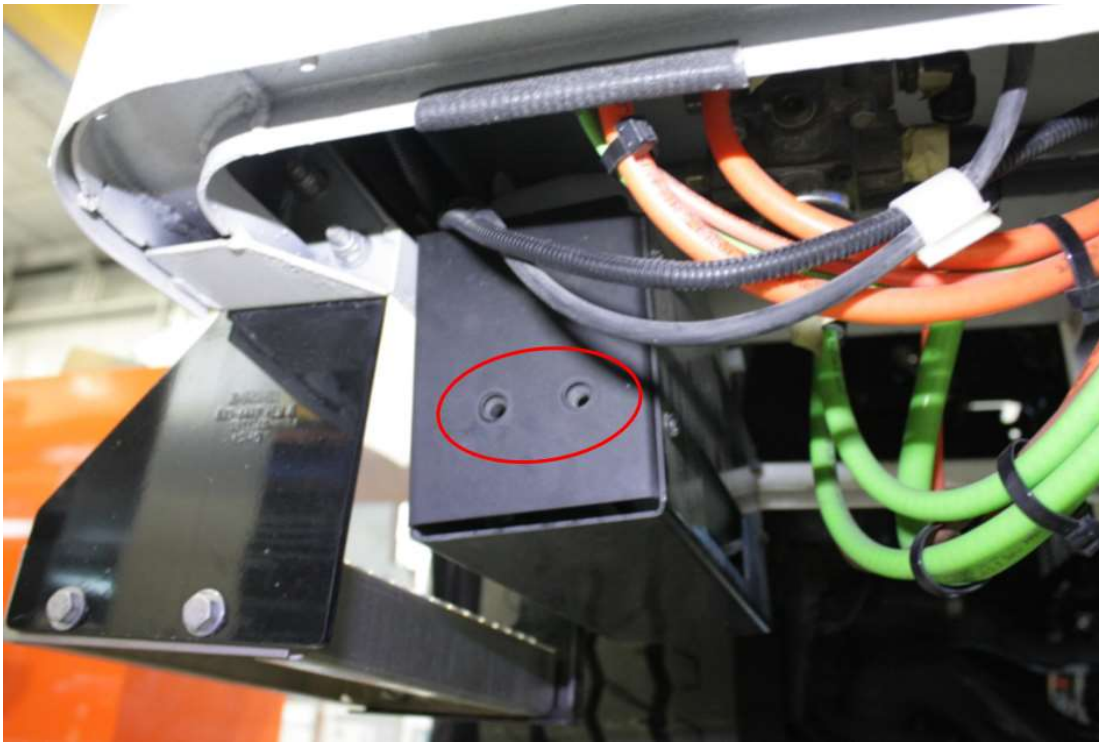

2. Using the images below, determine the correct plumbing for the QR valve and locate the primary delivery hose from the foot valve that will be routed to the QR valve.
3. Wrap the threads of the fittings with Teflon tape and install into the QR valve as shown for the appropriate steering configuration below.
4. Remove the primary delivery hose from the foot valve, trim the excess if necessary and install in the outlet port of the QR valve.
5. Cut a new section of hose to install from the QR valve inlet back to the foot valve.

Dual Seated Steer Plumbing

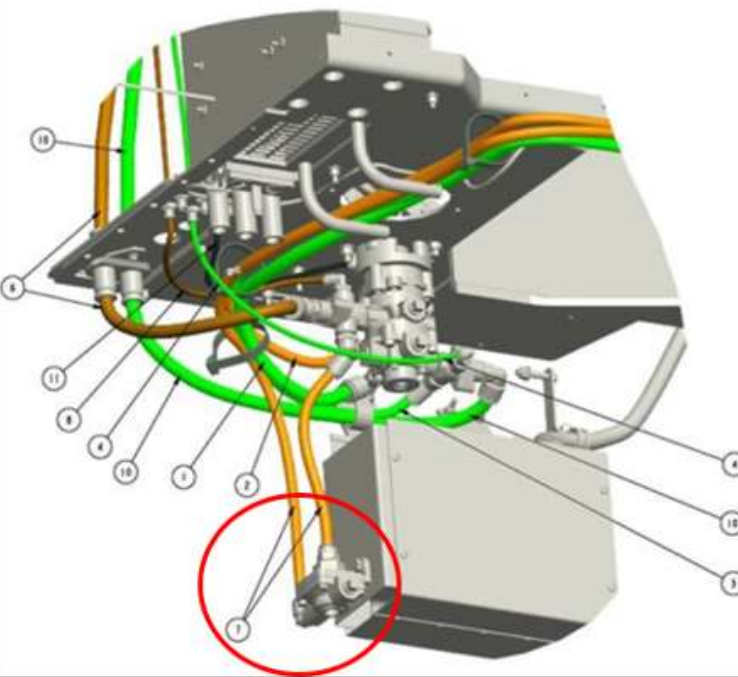
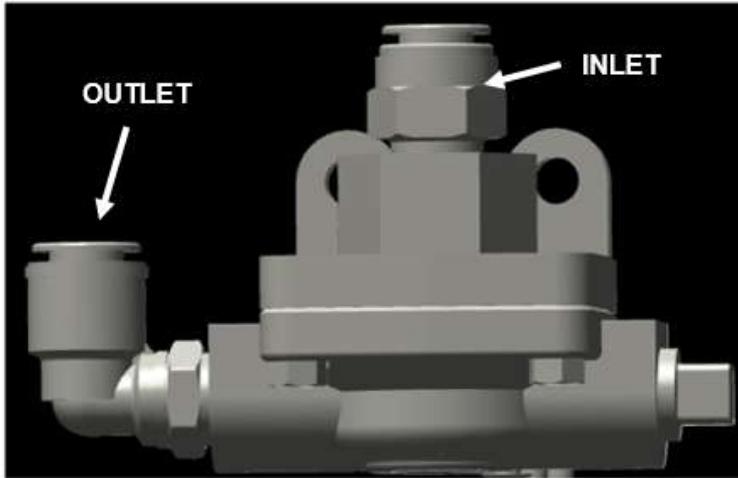

Right Hand Stand-up Plumbing

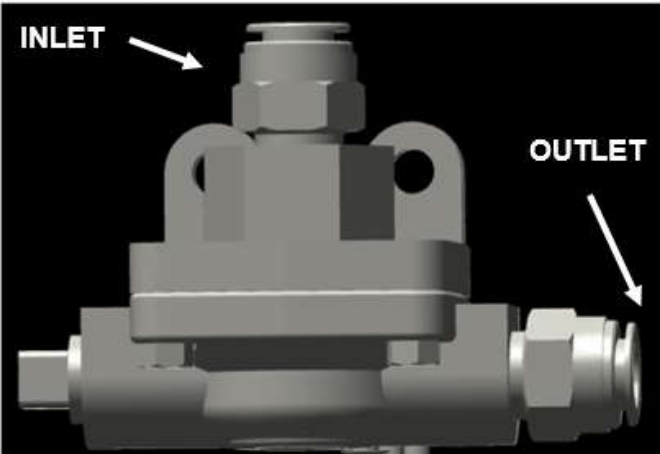

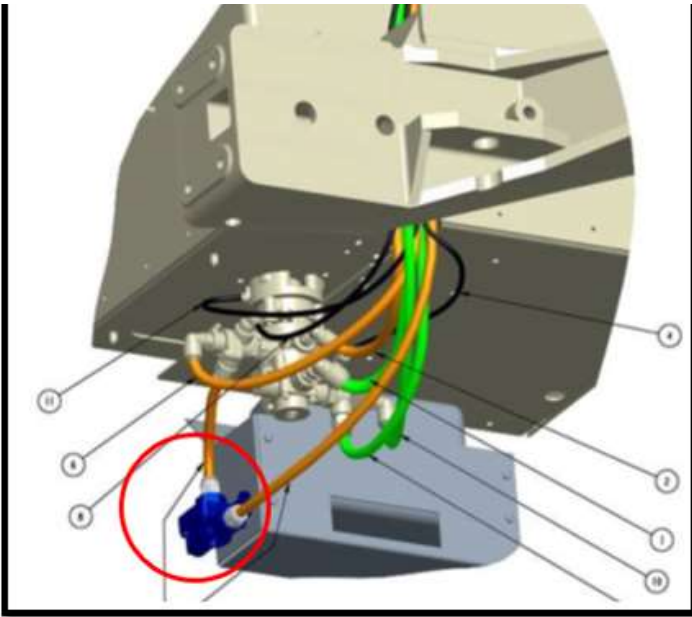

6. Avoid kinking the hoses and secure the hose bundle with cable ties.

Parts

Parts are available through PACCAR Parts.

DUAL SEATED DRIVE CONFIGURATION		
Quantity	Part Number	Description
1	288251BXW	Quick Release Valve
2	HWC01097	Hex Bolt
2	HWC03128	Flat Washer
1	G38-1021-0608	90 Degree Male Fitting
1	G38-1023-0608	Straight Male Fitting
1	AP2335	3/8 IN Plug
1 foot	Source Locally	#8 Orange or Black Nylon Brake Hose – 1 foot
As Needed	Source Locally	Teflon Tape
As Needed	Source Locally	Cable Ties

RH STAND-UP CONFIGURATION		
Quantity	Part Number	Description
1	288251BXW	Quick Release Valve
2	HWC01097	Hex Bolt
2	HWC03128	Flat Washer
2	G38-1023-0608	Straight Male Fitting
1	AP2335	3/8 IN Plug
1 foot	Source Locally	#8 Orange or Black Nylon Brake Hose – 1 foot
As Needed	Source Locally	Teflon Tape
As Needed	Source Locally	Cable Ties

Links

[Chassis List](#)

[Customer Letter](#)

Authored by: PR