

Product Safety Recall

N212329840 Engine Heater Short Circuit



Release Date: March 2022

Revision: 02

Revision Description: This bulletin is being revised to allow all locations to perform the full repair and to add the customer letter. Please discard all previous copies of N212329840.

Attention: It is a violation of Federal law for a dealer to deliver a new motor vehicle or any new or used item of motor vehicle equipment (including a tire) covered by this notification under a sale or lease until the defect or noncompliance is remedied.

All involved vehicles that are in dealer inventory must be held and not delivered to customers, dealer traded, or used for demonstration purposes until the correction contained in this bulletin has been performed on the vehicle.

Make	Model	Model Year		RPO	Description
		From	To		
Chevrolet	Silverado 2500/3500	2017	2019	L5P	6.6L, 8-cylinder diesel engine
GMC	Sierra 2500/3500				

Involved vehicles are marked Open on the Investigate Vehicle History screen in GM Global Warranty Management system. This site should always be checked to confirm vehicle involvement prior to beginning any required inspections and/or repairs.

Condition	General Motors has decided that a defect which relates to motor vehicle safety exists in certain 2017-2019 model year Chevrolet Silverado 2500/3500 and GMC Sierra 2500/3500 vehicles. In vehicles equipped with the Duramax diesel 6.6 liter engine and the optional engine-block heater cord, a short-circuit condition may develop in the engine-block heater cable or in the terminals that connect the heater cable to the block heater. A short-circuit condition can cause damage to engine components and, in rare cases, start a fire in the engine compartment.
Correction	Dealers are to replace the engine-block heater and cord.

Parts

Quantity	Part Name	Part No.
1	Engine Coolant Heater	12724955
1	Power Cord – Engine Coolant Heater	85590391
2	Dex-Cool Engine Coolant	12346290 US 10953464 Canada Obtain locally in compliance w/ GM spec GMW3420 and Material Specification 9985809 (all other countries)
4	Locally Sourced Automotive Quality Wire Tie	NPN

Note: The per gallon part number for coolant is listed in the part table. If your facility buys the correct coolant in a bulk quantity, do not order the gallon units.

Reminder: Parts may be removed from Retail Inventory Management (RIM). Dealers should review the affected parts to confirm RIM managed status. Parts may have quantity limiters in effect.

Warranty Information

Labor Operation	Description	Labor Time	Trans. Type	Net Item
9106096	Install Revised Engine Coolant Heater Element and Cord ADD: Remove Existing Engine Coolant Heater Power Cord	1.5 0.1	ZFAT	N/A
9105851	Customer Reimbursement Approved - For USA and Canada dealers only - For Export dealers only	N/A 0.2	ZFAT	*
9105852	Customer Reimbursement Denied – For USA dealers only	N/A	ZFAT	**

Note: To avoid having to “H” route the customer reimbursement transaction for approval, it must be submitted prior to the repair transaction.

Product Safety Recall

N212329840 Engine Heater Short Circuit



*For USA and Canada: Submit the dollar amount reimbursed to the customer in Net/Reimbursement. Submit \$20.00 USD (\$25.00 CAN) administrative allowance in Net/Admin Allowance.

For Export: Submit the dollar amount reimbursed to the customer in Net/Reimbursement.

**Submit \$10.00 USD administrative allowance in Net/Admin Allowance.

Service Procedure

Note: A training video was created to supplement the written service procedure below. The training video is available on the GM Center of Learning web site (centerlearning.com) to aid technicians with this repair. After logging into the website, U.S. dealers should select the GM Media Tube app. Perform a search for N212329840. The course number is 56521.16V. Canadian dealers should access the "Video On Demand" site within the Resources page of the Centre of Learning. Select Feature Topics followed by "TAC Talk" February 2022 Feature Topic".

DANGER: When performing the following repairs, ensure the engine and coolant are at room temperature. When removing the engine block heater, the coolant in the engine will drain out. This coolant may injure the technician if the coolant is hot.

Note: It is critical that the radiator surge tank is topped off with an additional **1.6 L (2 qt)** of coolant to fill the upper and lower radiator surge tank chambers. If the coolant tank is not purged and filled properly, there will be air pockets in the coolant tank which will require the customer to return to the dealership to address low coolant warning.

Note: Some vehicles may have had the engine block heater power cord removed under a previous campaign. If the power cord has been removed, proceed directly to step #4.

1. Raise the hood and locate the engine heater power cord (bundled at the right-side front of dash area).

Note: Some attachment points may use tape to secure the power cord to the vehicle wiring harness. Use care to not cut the vehicle wiring harness when removing these attachment points.

2. Locate and remove all of engine compartment power cord attachment points.
3. Drop the existing power cord to the underside of the vehicle.
4. Remove the new service engine heater power cord from the box and uncoil the cord.
5. Lower the engine heater element end of the new power cord to the underside of the vehicle.

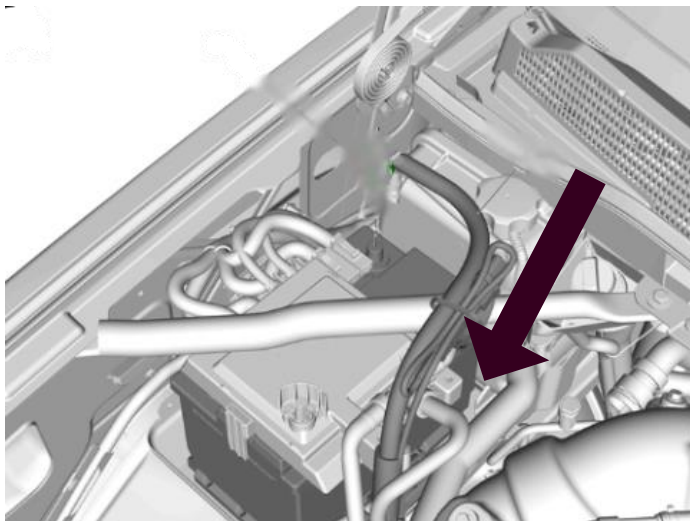

5946406

- Start lowering the cord inboard of the battery toward the front of dash.

Product Safety Recall

N212329840 Engine Heater Short Circuit

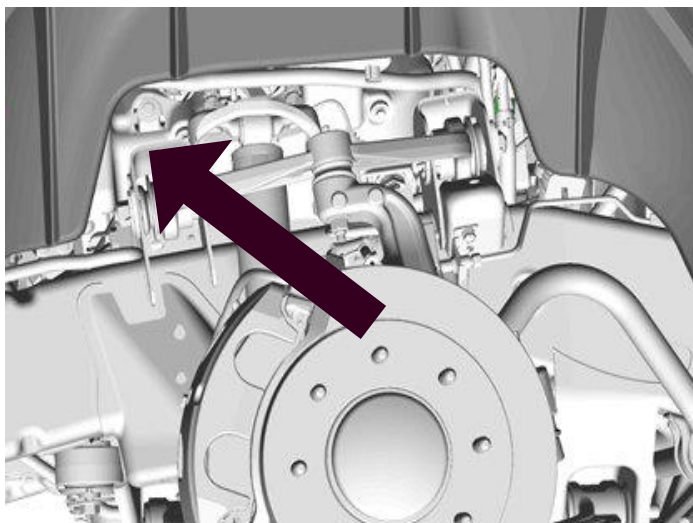

5946404

- It should come out in the area identified above.
6. Raise the vehicle and remove the right front wheel. Refer to *Tire and Wheel Removal and Installation (8-Lug Wheel)* in SI.
 7. Remove the right front wheelhouse liner. Refer to *Front Wheelhouse Liner Replacement - Right Side* in SI.



5420809

8. Looking through the area between the frame and suspension, locate the engine block heater.
9. Disconnect the engine block heater plug from the heater element by releasing the retainer clip and unplugging.
10. Remove any existing engine heater power cord fasteners and remove the power cord. Discard the power cord.

Note: It is not necessary to drain the radiator. The engine block coolant will be drained when the engine coolant heater is removed.

Product Safety Recall

N212329840 Engine Heater Short Circuit



5420812

Note: The removal of the old coolant heater element requires a 30mm Socket wrench. The installation of the new coolant heater element requires a 26mm socket wrench.

11. Place a large drain pan under the vehicle to capture the coolant. Remove the engine coolant heater. Refer to *Engine Coolant Heater Replacement (L5P)* in SI.
12. After removing the original block heater, take care to remove the old cured thread sealant in the block. Failure to remove the old thread sealant will result in cross threading or binding of the replacement block heater.

Caution: Do not under torque the engine coolant heater. This can result in a coolant leak. A torque wrench, with tactile or audible feedback when torque has been achieved, should be used. Tighten to 90 N.m. (66 lb ft). **DO NOT OVERTIGHTEN.** Hand start the block heater carefully and secure at least 3 full turns before further tightening with a socket wrench.

Note: The new engine block heater element has the thread sealer applied at the time of manufacture. **DO NOT INSTALL ADDITIONAL SEALER** to the threads.



5946408

13. Hand start the block heater carefully and secure at least 3 full turns before further tightening with a socket wrench.
14. Tighten to 90 N.m. (66 lb ft). **DO NOT OVERTIGHTEN.** A torque wrench, with tactile or audible feedback when torque has been achieved, should be used.

Product Safety Recall

N212329840 Engine Heater Short Circuit

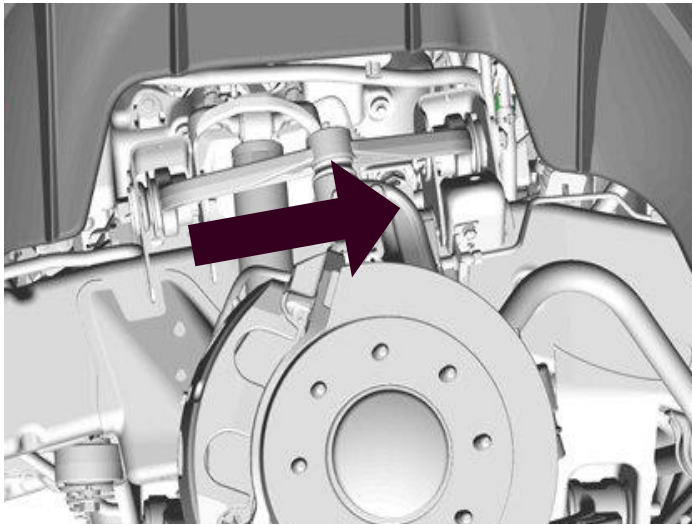

5946410

15. Slide the new power cord forward in the vehicle, toward the coolant heater element. Place the power cord connector near the coolant heater element. **DO NOT CONNECT** the power cord to the heater element at this time, it will be connected after the cooling system pressure test.

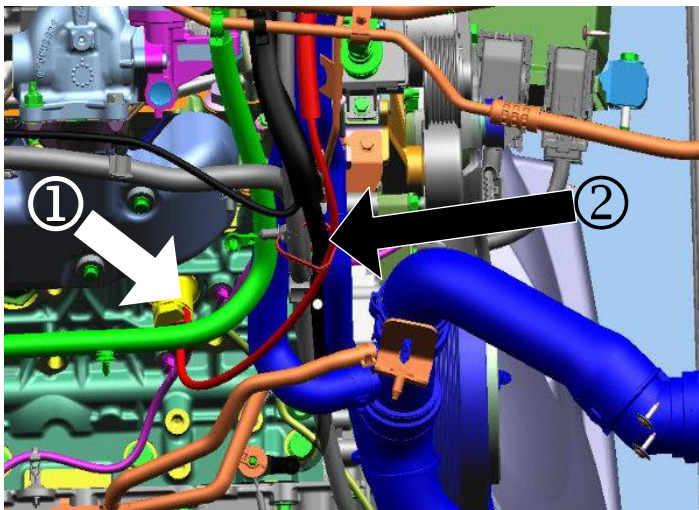

5495375

16. Route the new engine coolant heater power cord (shown in red) to the upper motor compartment. Begin at the Element (1) and secure the wire tie (2) around the negative battery cable (black) and the engine chassis harness (grey).
17. Lower the vehicle.

Product Safety Recall

N212329840 Engine Heater Short Circuit

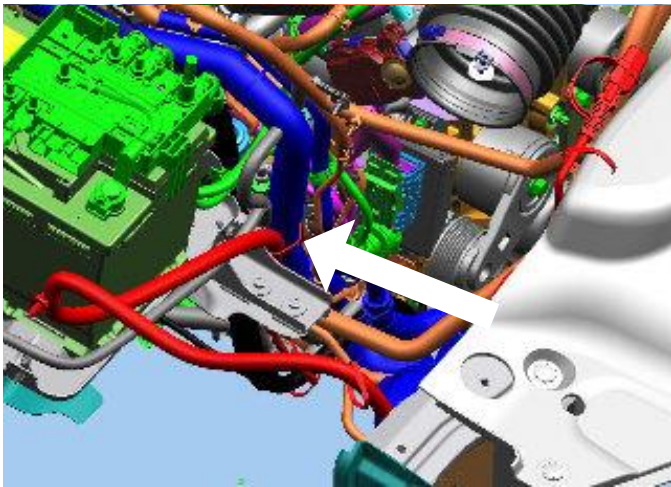

5495378

18. Route the power cord (shown in red) as shown and secure to the surge tank hose (blue) with a wire tie.

Engine Compartment Routing Overview

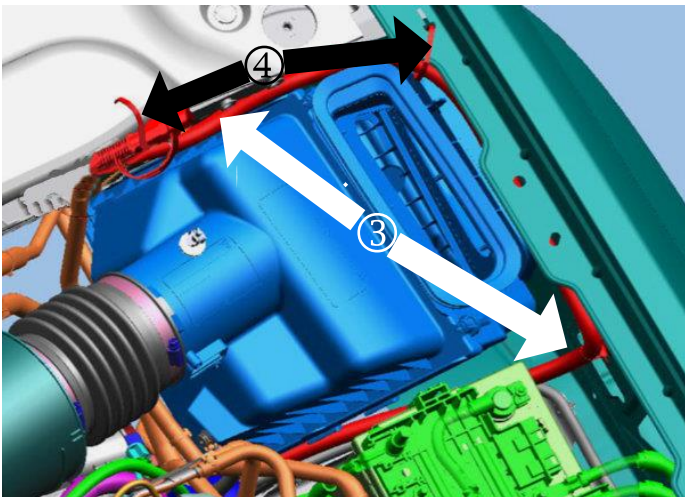

5946413

Push pin attachments (3), wire tie attachments (4).

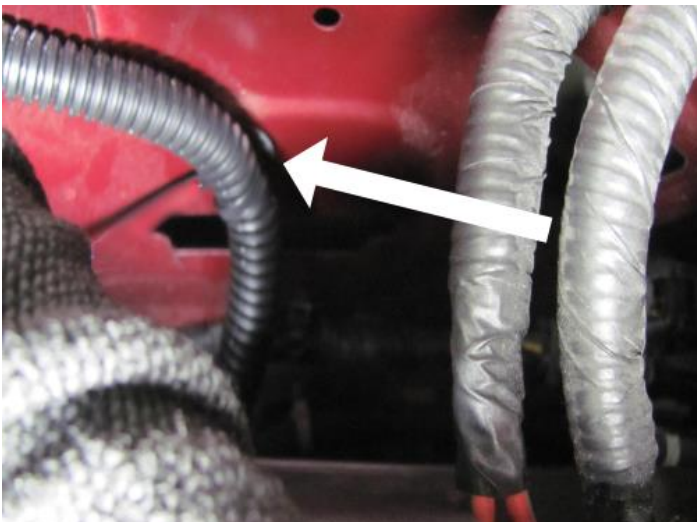

5420816

Product Safety Recall

N212329840 Engine Heater Short Circuit



19. Position the power cord along the inner fender and secure to the existing hole using the first (closest to the heater element) push pin wire tie attached to the harness.



5420817

20. Secure the power cord to the fender flange with a wire tie as shown. Some vehicles may have a hood seal or headlamp attachment at this location. Position the wire tie under the seal/bracket.



5420818

21. Locate the drill location on the front compartment front sight shield. Mark the location.

Product Safety Recall

N212329840 Engine Heater Short Circuit



5420819

22. Drill a 5mm (13/64 in.) hole in the marked area. Use care to not damage components below the drill location.
23. Route the power cord from the fender flange area under the front compartment front sight shield.



5420820

24. Create a gentle bend in the power cord and place the power cord plug over the hole in the site shield. Ensure the prongs on the power cord plug are facing toward the right fender.

Product Safety Recall

N212329840 Engine Heater Short Circuit



5420823

25. Secure the power cord plug to the front compartment front sight shield with a wire tie as shown. Ensure the prongs are facing toward the right front fender.



5420824

26. Locate the hole on the passenger side upper tie bar bracket.

Product Safety Recall

N212329840 Engine Heater Short Circuit



27. Position the harness up under the front compartment front sight shield and secure it using the second (closest to the electrical plug) push pin wire tie on the harness.
28. Trim all wire ties as necessary.

Important: The Vac-N-Fill Procedure must be used when refilling the cooling system. If the Vac-N-Fill Procedure is not used, the customer will return to the dealership with a low coolant condition.

29. Fill the cooling system. Refer to *Cooling System Draining and Filling (Vac N Fill)* in SI.
30. Pressurize the cooling system. Refer to *Cooling System Leak Testing (L5P)* in SI.
31. Partially raise the vehicle and inspect the new engine block heater for coolant leaks.
 - Inspect the interface between the engine block heater and the engine block (threaded area) for leaks.
 - Check the cavity where the electrical connector fits for leaks.
32. Plug the new engine coolant heater cord assembly into the heater and secure it with the metal clip.
33. Reinstall the right front wheelhouse liner. Refer to *Front Wheelhouse Liner Replacement - Right Side* in SI.
34. Reinstall the right front wheel and tire. Refer to *Tire and Wheel Removal and Installation (8-Lug Wheel)* in SI.
35. Remove the leak testing equipment from the surge tank.

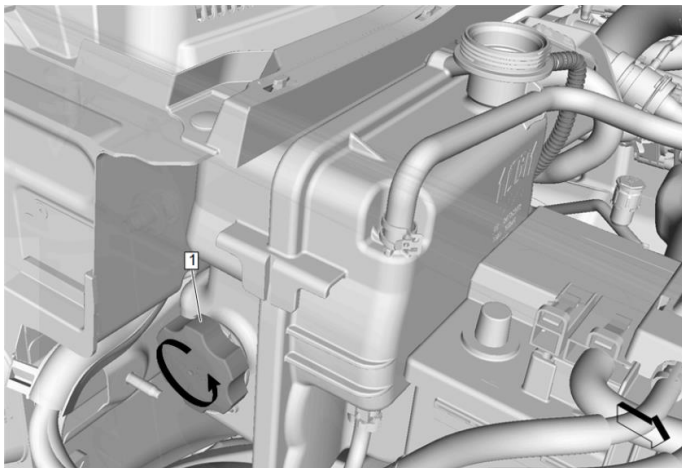

36. Open the lower radiator surge tank cap (1) a $\frac{1}{4}$ of a turn counterclockwise.

Product Safety Recall

N212329840 Engine Heater Short Circuit

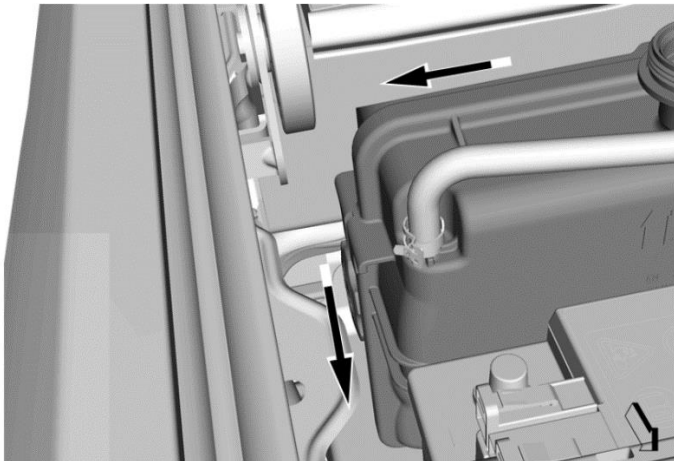

5443213

37. Using a funnel, slowly fill the radiator surge tank with **1.6 L (2 qt)** of coolant to fill the lower radiator surge tank chamber. The overflow tube will flow to the left and down as shown above, and slowly move to the lower radiator surge tank chamber.

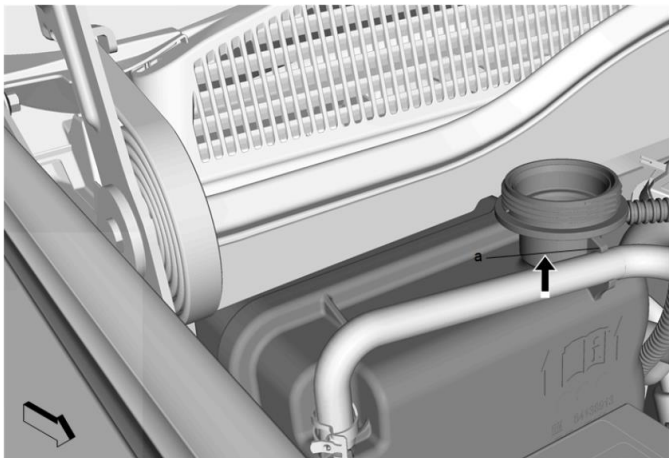

5443214

38. When completed, the radiator surge tank should be filled as shown above (a).

Note: Be sure the lower radiator surge tank cap is completely closed and locked in place to avoid getting air into the cooling system after filling. There will be a snap sound when the cap is completely closed and locked in place.

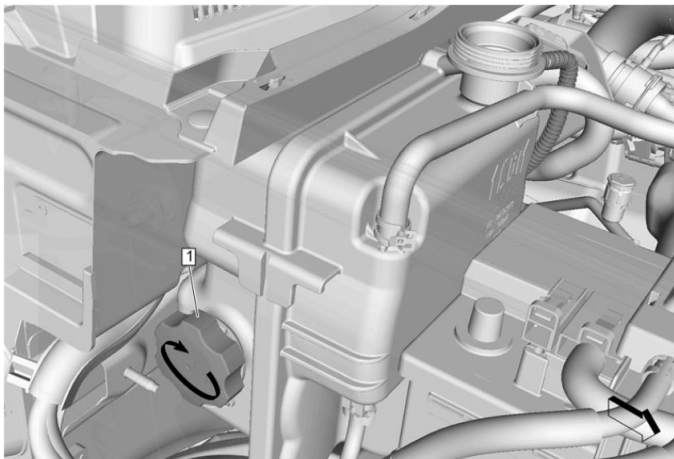

5443215

39. Close the lower radiator surge tank cap (1) clockwise.

Product Safety Recall

N212329840 Engine Heater Short Circuit

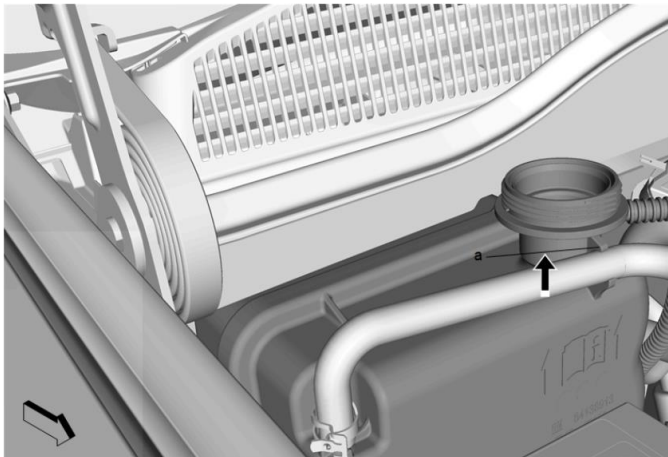

5443214

40. If the coolant level is below the fill neck level shown (a) add coolant to the fill neck level shown.
41. Install radiator surge tank cap by turning counterclockwise.
42. Rinse away any excess coolant from the engine and the engine compartment.
43. Perform the following check list before delivering the vehicle to the customer:
 - Drain/fill/burp coolant system with vac/fill equipment.
 - Cord attached with 4 tie straps.
 - Cord attached with 2 push pin wire ties.
 - Engine block heater torqued to 90 N.m. (66 lb ft).
 - Cord properly connected to heater with metal clip engaged.

Dealer Responsibility – For USA & Export (USA States, Territories, and Possessions)

It is a violation of Federal law for a dealer to deliver a new motor vehicle or any new or used item of motor vehicle equipment (including a tire) covered by this notification under a sale or lease until the defect or noncompliance is remedied.

The US National Traffic and Motor Vehicle Safety Act provides that each vehicle that is subject to a recall of this type must be adequately repaired within a reasonable time after the customer has tendered it for repair. A failure to repair within sixty days after tender of a vehicle is prima facie evidence of failure to repair within a reasonable time. If the condition is not adequately repaired within a reasonable time, the customer may be entitled to an identical or reasonably equivalent vehicle at no charge or to a refund of the purchase price less a reasonable allowance for depreciation. To avoid having to provide these burdensome remedies, every effort must be made to promptly schedule an appointment with each customer and to repair their vehicle as soon as possible. In the recall notification letters, customers are told how to contact the US National Highway Traffic Safety Administration if the recall is not completed within a reasonable time.

Dealer Responsibility – All

All new, used, GM Certified Used, courtesy transportation vehicles, dealer shuttle vehicles, etc. in dealers' possession and subject to this recall must be held and inspected/repared per the service procedure of this bulletin before customers take possession of these vehicles. Involved vehicles must be held and not delivered to customers, dealer-traded, released to auction, used for demonstration, or any other purpose.

All GM Certified Used vehicles currently in the dealers' inventory within the Certified Pre-Owned Inventory System (CPOIS) will be de-certified and must be held and remedied per the service procedure in this bulletin. Upon submitting an accepted/paid warranty transaction in the Global Warranty Management (GWM) system, the vehicle can be re-certified for sale within the CPOIS system, or once again be used in the CTP program.

Dealers are to service all vehicles subject to this recall at no charge to customers, regardless of mileage, age of vehicle, or ownership, from this time forward.

Customers who have recently purchased vehicles sold from your vehicle inventory, and for which there is no customer information indicated on the dealer listing, are to be contacted by the dealer. Arrangements are to be made to make the required correction according to the instructions contained in this bulletin. A copy of the customer letter is provided in this

Product Safety Recall

N212329840 Engine Heater Short Circuit



bulletin for your use in contacting customers. Recall follow-up cards should not be used for this purpose, since the customer may not as yet have received the notification letter

In summary, whenever a vehicle subject to this field action enters your vehicle inventory you must take the steps necessary to ensure the program correction has been made before selling the vehicle. In addition, for vehicles entering your facility for service, you are required to ensure the customer is aware of the open field action and make every reasonable effort to implement the program correction as set forth in this bulletin prior to releasing the vehicle.

Dealer Reports

For dealers with involved vehicles, a listing has been prepared and will be available through GM GlobalConnect Maxis Field Action Reports or sent directly to export dealers. The Inventory tab of the dealer reports will contain VINs that apply to this recall. This information is intended to assist dealers with the **PROMPT COMPLETION** of these vehicles. The Customer In-Service tab will contain customer names and addresses from Motor Vehicle Registration Records. The use of such motor vehicle registration data for any purpose other than follow-up necessary to complete this recall may be a violation of law in several states.

Courtesy Transportation – For USA & Canada

Courtesy transportation is available for customers whose vehicles are involved in a product program and still within the warranty coverage period. See General Motors Service Policies and Procedures Manual for courtesy transportation program details.

Customer Notification

USA & Canada - General Motors will notify customers of this recall on their vehicle (see copy of customer letter included with this bulletin).

Export - Letters will be sent to known owners of record located within areas covered by the US National Traffic and Motor Vehicle Safety Act. For owners outside these areas, dealers should notify customers using the attached sample letter.

Customer Reimbursement

Customer requests for reimbursement of previously paid repairs to correct the condition described in the bulletin can be submitted at anytime to the dealer. See General Motors Service Policies and Procedures Manual, Product Field Action Customer Reimbursement Procedure (USA & Canada) or local Policies and Procedures, for details.

GM bulletins are intended for use by professional technicians, NOT a "do-it-yourselfer". They are written to inform these technicians of conditions that may occur on some vehicles, or to provide information that could assist in the proper service of a vehicle. Properly trained technicians have the tools, equipment, safety instructions, and know-how to do a job properly and safely. If a condition is described, **DO NOT** assume that the bulletin applies to your vehicle, or that your vehicle will have that condition. See your dealer for information on whether your vehicle may benefit from the information.



**We Support
Voluntary Technician
Certification**



IMPORTANT SAFETY RECALL

April 2022

This notice applies to your vehicle, **VIN:** _____

Dear General Motors Customer:

This notice is sent to you in accordance with the National Traffic and Motor Vehicle Safety Act.

General Motors has decided that a defect, which relates to motor vehicle safety, exists in certain 2017 – 2019 model year Chevrolet Silverado 2500/3500 HD and GMC Sierra 2500/3500 HD vehicles equipped with the Duramax diesel 6.6 liter engine and optional engine-block heater cord. As a result, GM is conducting a safety recall. We apologize for this inconvenience. However, we are concerned about your safety and continued satisfaction with our products.

IMPORTANT*You may have already had a recall repair previously performed on your vehicle under GM recall N182206310 or N182206311. General Motors has determined that additional repairs are necessary to make the block heater on your vehicle safe to use.**

Until this repair is performed on your vehicle, you should not use your vehicle's engine-block heater.

IMPORTANT

- Your vehicle is involved in GM safety recall N212329840.
- You may have already had a recall repair previously performed on your vehicle under GM recall N182206310 or N182206311. General Motors has determined that additional repairs are necessary to make the block heater on your vehicle safe to use.
- Regardless of whether or not you have previously had a recall repair performed on your vehicle, you should not use your vehicle's engine block heater until further repairs are performed.

Why is your vehicle being recalled?

In vehicles equipped with the Duramax diesel 6.6 liter engine and the optional engine-block heater cord, a short-circuit condition may develop in the engine-block heater cable or in the terminals that connect the heater cable to the block heater. A short-circuit condition can cause damage to engine components and can increase the risk of a fire in the engine compartment.

What will we do?

Your GM dealer will replace the engine-block heater and cord. This service will be performed for you at **no charge**. **Until this repair is performed on your vehicle, you should not use your vehicle's engine-block heater.**

What should you do?

You should contact your GM dealer to arrange a service appointment as soon as possible.

Did you already pay for this repair?

Even though you may have previously had repairs for this condition, you will still need to take your vehicle to your dealer for additional repairs. If you have already paid for repairs for the recall condition, please complete the enclosed reimbursement form and present it to your dealer with all required documents. Working with your dealer will expedite your request, however, if this is not convenient, you may mail the completed

Product Safety Recall

N212329840 Engine Heater Short Circuit



reimbursement form and all required documents to Reimbursement Department, PO Box 33170, Detroit, MI 48232-5170.

Do you have questions?

If you have questions or concerns that your dealer is unable to resolve, please contact the appropriate Customer Assistance Center at the number listed below.

For the hearing or speech impaired, please contact our Customer Assistance Center using the Telecommunication Relay Service by dialing 711 then providing the appropriate Customer Assistance Center number for your vehicle.

Division	Number	Text Telephones (TTY)
Chevrolet	1-800-630-2438	1-800-833-2438
GMC	1-866-996-9463	1-800-462-8583
Puerto Rico – English	1-800-496-9992	
Puerto Rico – Español	1-800-496-9993	
Virgin Islands	1-800-496-9994	

If after contacting your dealer and the Customer Assistance Center, you are still not satisfied we have done our best to remedy this condition without charge and within a reasonable time, you may wish to write the Administrator, National Highway Traffic Safety Administration, 1200 New Jersey Avenue, SE, Washington, DC 20590, or call the toll-free Vehicle Safety Hotline at 1.888.327.4236 (TTY 1.800.424.9153), or go to <http://www.safercar.gov>. The National Highway Traffic Safety Administration Campaign ID Number for this recall is 21V496.

Federal regulation requires that any vehicle lessor receiving this recall notice must forward a copy of this notice to the lessee within ten days.

Regina A. Carto
Vice President
Global Product Safety and Systems

Enclosure
GM Recall: N212329840