



# TRAIL KING Industries, Inc.

---

300 East Norway Avenue  
Mitchell, SD 57301-4777  
Phone: (800) 843-3324  
Fax: (605) 996-4727

2130 3<sup>rd</sup> Avenue NW  
West Fargo, ND 58078-1343  
Phone: (800) 762-5557  
Fax: (701) 282-3039

1200 Gehl Drive  
Yankton, SD 57078  
Phone: (605) 665-8415  
Fax: (605) 665-0810

---

TO: Valued TKOLB Trailer Customer

NHTSA Recall Number: 21V541

Trail King Recall Number: TK202103

DATE: January 31, 2023

## **IMPORTANT SAFETY RECALL**

This notice applies to your vehicle with VIN: \_\_\_\_\_.

Trail King has decided that a defect that relates to motor vehicle safety exists in the Dexter Steer Axle(s) on certain Trail King TKOLB332NG-HH, OLB336NG, OLB336NG-HH, OLB434NG-HH, and OLB436NG-HH models.

### **What Trailers are being recalled:**

This recall affects Trail King TKOLB332NG-HH, OLB336NG, OLB336NG-HH, OLB434NG-HH, and OLB436NG-HH models. 2018 – 2020 model years that have manufacture dates from July 2017 through August 2019.

### **What is the Problem?**

Dexter Axle has determined that in certain low-speed loading scenarios, the side loads generated on the steer axles may be enough to cause the attaching hardware to fail. The steering arm may become detached from the steering knuckle. If that occurs, there is a potential for pieces of the attachment hardware to separate and fall onto the road which may result in a loose projectile increasing the potential risk for a crash.

### **What should you do?**

Obtain and confirm your trailer's serial number from the VIN plate located on the driver's side of the frame. You are receiving this letter because our records show you are the current owner of this vehicle.

You should inspect the steer arm and bolts on your steer axle and contact Dexter Axle as directed below to make an appointment to have your trailer repaired.

## What will we do?

Trail King Industries is coordinating with Dexter Axle to conduct a safety recall campaign to address this issue. Dexter Axle Company will do the work to correct the trailers in the field. Dexter Axle will provide up to 3 hours of labor and replacement parts necessary to remedy units.

Please contact Dexter Axle directly at [RecallsB009R@dexteraxle.com](mailto:RecallsB009R@dexteraxle.com) or by calling Phil Schnurr at 1-226-242-5345 to identify an authorized Dexter repair facility that can update their trailer. Please reference recall 21E-019.

If this repair has already been performed prior to receipt of this notification, you may be eligible to receive reimbursement for the cost of obtaining a pre-notification remedy of the problem associated with this recall. For more information, contact Trail King at the phone number noted below.

If you no longer own the vehicle covered by this Safety Recall Notice, please provide the name and contact information for the new owner by contacting Trail King Industries at 1-800-843-3324 and ask for Customer Service or email to [Customerservice@trailking.com](mailto:Customerservice@trailking.com). This will enable us to advise the new owner of this recall.

Pursuant to Federal Law, any vehicle lessor receiving this recall notice must forward a copy of this notice to the lessee within ten (10) days.

If Trail King Industries or Dexter Axle fails or is unable to provide a remedy within a reasonable time, you may wish to contact the Administrator, National Highway Traffic Safety Administration, 1200 New Jersey Avenue, SE, Washington, DC 20590, or call the toll-free Auto Safety Hotline at 1-888-327-4236 (TTY: 1-800-424-9153); or contact NHTSA at <http://www.safercar.gov>.

We regret any inconvenience this may cause you, but we are initiating this action in the interest of your personal safety and satisfaction with our products.

Sincerely,  
Customer Service

Trail King Industries  
300 East Norway  
Mitchell, SD 57301  
1-800-843-3324 (Toll Free)

# TRAIL KING industries

*Serving our customers since 1974.*



300 East Norway Avenue  
Mitchell, SD 57301-4777

2130 3rd Avenue NW  
West Fargo, ND 58078-1343

1200 Gehl Drive  
Yankton, SD 57078

TO: Valued TKOLB Trailer Customer

NHTSA Recall Number: 21V541

## IMPORTANT SAFETY RECALL

### THIRD NOTIFICATION

DATE: January 31, 2023

On or about July 15, 2021, you were notified of a recall that affects your Trail King OLB trailer. To date, Trail King Industries, Inc. has no record of repairing your trailer. A copy of the original notice and the associated instructions with details on how to get your trailer repaired are enclosed.

Of course, do not hesitate to call Trail king Customer Service at 1-800-843-3324 if you have any questions.

Sincerely,  
Customer Service

#### **TRAIL KING Industries**

300 East Norway  
Mitchell, SD 57301  
1-800-843-3324 (Toll-Free)

Phone: (800) 843-3324 | Fax: (605) 996-4727 | [trailking.com](http://trailking.com) | [@trailkingind](https://twitter.com/trailkingind)

**BUILDING** THE BEST TRAILERS IN THE WORLD FOR OUR CUSTOMERS' **SUCCESS**

Date: December 4, 2019

**Subject: SMART-STEER 2.0 Bolt-On Steer Arm Reinforcement Welds**

Based on feedback from our customers, Dexter Heavy Duty has become aware that under certain loading conditions, the 8-7/8" steer arm setup on the SMART-STEER 2.0 axle is prone to shearing the attaching steer arm bolts. This will lead to a failure in the steer arm assembly.

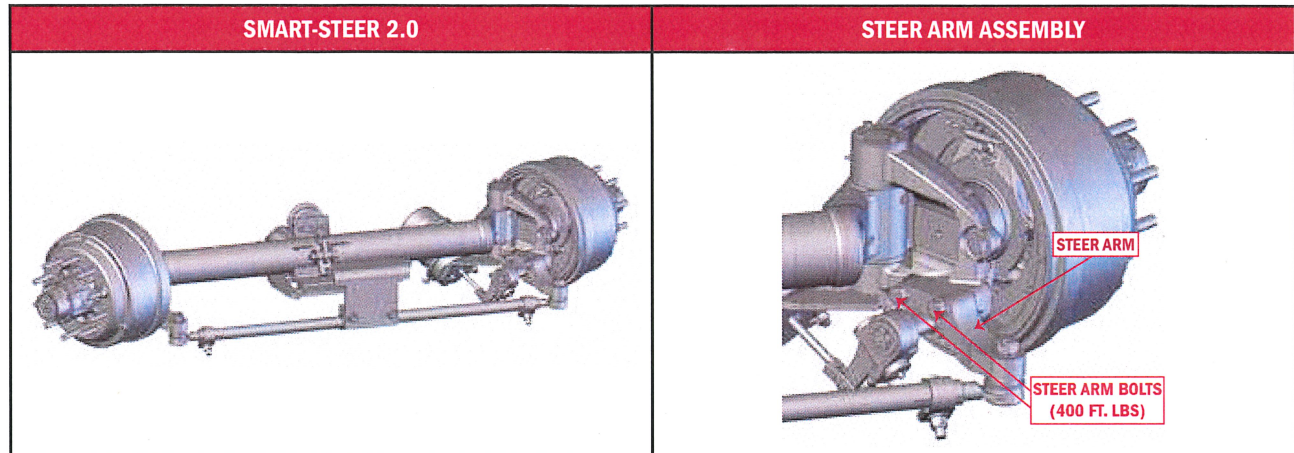

Dexter recommends that you perform a steer arm inspection of your axle(s) as soon as possible; but no later than four weeks after receiving this service bulletin. Please follow the steps listed below:

1. Visually inspect steer arm bolts and washers for mechanical tightness and replace if necessary.
2. Ensure the steer arm bolts are torqued to 400 Ft. Lbs.
3. Place welds as shown on page three of this bulletin. If you would like a copy of engineering drawing 750049, please contact one of the service technicians listed below.

A reference table of impacted models is on page two of this service bulletin.

Please contact your Dexter Heavy Duty Field Service Technicians Rudy Wosing or Phil Schnurr at (226) 242-5291 if you have additional questions or need further clarification.

We appreciate your understanding as we determine a long term solution to this issue.

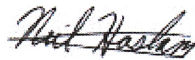

Neil Haslam  
Engineering Manager - Dexter Heavy Duty

### 8-7/8" TIE-ROD SMART-STEER 2.0 MODELS

SSA MODEL NUMBER	
750002	750265-3
750027	750265-5
750882	750650-3
750899	750650-5
750912	750688-3
750923	750882T
750924	750899T
750928	750912T
750929	750924-1
751003	750924-2
751004	750924T
751328	750928-3
751769	750928T
752270	751003-10
752299	751104T
752333	751384T
752346	751525-2
752347	751644-1
752529	752323-3
771004	752708-2
750265-2	

The model number can be found in the ordering variant description.

VARIANT #	VARIANT DESCRIPTION
TEST123-DXT123456	ISS-SSA <b>751004</b> -09110N-511IMT23-CAH

Upon inspection; if the steer arm bolts or steer arm are worn or damaged, below is the replacement steer arm kit for these models.

### 702732-01 BOLT-ON STEER ARM SERVICE KIT (-8-7/8") LH OR RH

ITEM NUMBER	QUANTITY	PART NUMBER	Description
1	1	701657	STEERING ARM B/O -8-7/8" TH
2	2	702834	BOLT, 3/4-16 UNF-2B X 3.75" LG GR8
3	2	701810	WASHER FLAT .75" GR8 MC2
Not Shown	1	0150425	LOCTITE®, BLUE 242, 0.5ML

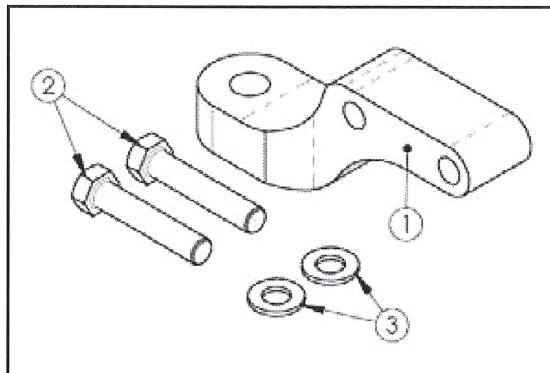

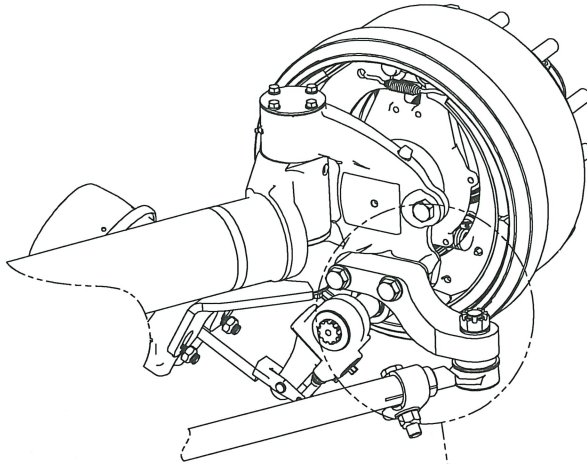

NOTE:  
TURN KNUCKLE AT FULL TURN TO  
GAIN ACCESS TO STEER ARM  
AND WELD

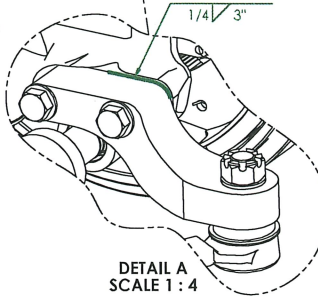

DETAIL A  
SCALE 1 : 4

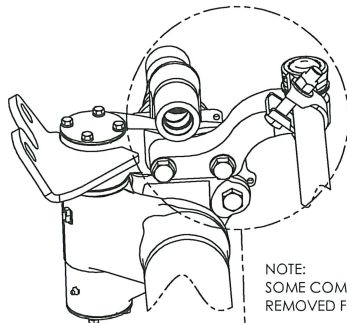

NOTE:  
SOME COMPONENTS WERE  
REMOVED FOR CLARITY.

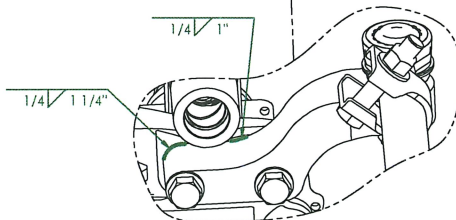

DETAIL C  
SCALE 1 : 4

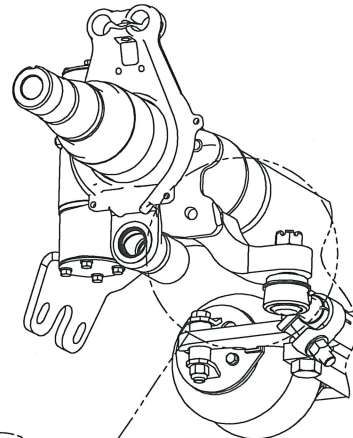

NOTE:  
SOME COMPONENTS WERE  
REMOVED FOR CLARITY.

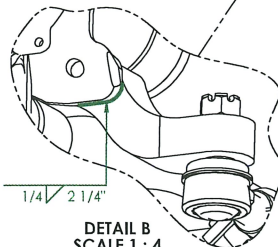

DETAIL B  
SCALE 1 : 4