

**November 30, 2021**

Version 1

## Safety Recall: Hood Vibration at Highway Speeds

### AFFECTED VEHICLES

Year	Model	Trim	VIN Range
2019	Passport	ALL	Check the iN VIN status for eligibility
2016–19	Pilot	ALL	Check the iN VIN status for eligibility
2017–20	Ridgeline	ALL	Check the iN VIN status for eligibility

### BACKGROUND

Due to an improper hood to grill gap setting at the time of vehicle manufacturing, the hood latch may experience higher than expected load under certain driving conditions. Strong air pressure forced through this gap may cause the hood to vibrate which, over time, may cause the area surrounding the hood latch striker to crack and potentially dislodge, presenting a risk for the hood to open while driving and increasing the risk of a crash.

### CUSTOMER NOTIFICATION

Owners of affected vehicles will be sent a notification of this campaign.

Do an iN VIN status inquiry to make sure the vehicle is shown as eligible.

Some vehicles affected by this campaign may be in your new or used vehicle inventory.

Failure to repair a vehicle subject to a recall or campaign may subject your dealership to claims or lawsuits from the customer or anyone else harmed as a result of such failure. Before selling a vehicle in inventory, always check if it is affected by a safety recall by conducting a VIN status inquiry.

### CORRECTIVE ACTION

Follow the inspection procedure to determine if the hood is repairable. If any of the inspection areas fail, replace the hood.

### PARTS INFORMATION

#### For Hood Repair

Part Name	Part Number	Quantity
Hood Striker Repair Kit (Contains (1) Striker Plate and (3) 6 MM Bolts and Washers).	60110-TG7-305	1
Spot Weld repair Kit (Contains (1) Rivet and (1) Washer).	06601-TG7-305	1

**CUSTOMER INFORMATION:**The information in this bulletin is intended for use only by skilled technicians who have the proper tools, equipment, and training to correctly and safely maintain your vehicle. These procedures should not be attempted by "do-it-yourselfers," and you should not assume this bulletin applies to your vehicle, or that your vehicle has the condition described. To determine whether this information applies, contact an authorized Honda automobile dealer.

**For Hood Replacement**

<b>Part Name</b>	<b>Part Number</b>	<b>Quantity</b>
Hood Component	60100-TG7-A92ZZ	1
Emission Label (Must Replace) (Due to P/N variation between models/years, you may add the label P/N in the replacement parts section of the template)	Refer to Parts Bulletin 18-0021 for ordering instructions.	1
Air Conditioner Label - (Must Replace) (Check by VIN in the Parts Catalog for Proper Application)	80050-TG7-A00	1
Air Conditioner Label - (Must Replace) (Check by VIN in the Parts Catalog for Proper Application)	80050-T6Z-A00	1
Air Conditioner Label - (Must Replace) (Check by VIN in the Parts Catalog for Proper Application)	80050-TYR-A00	1
Rubber Hood Seal (If Needed)	74146-TG7-A01	1
Hood Cushion (If Needed)	91601-SYC-J00	2
Hood Cushion (If Needed)	91603-S9A-003	3
Insulator Clip (If Needed)	91502-TZ5-A01	8

**TOOLS INFORMATION**

<b>Part Name</b>	<b>Part Number</b>	<b>Quantity</b>
Striker and Spot Weld Inspection Template kit (Contains 1 Inspection Template, and 2 Fender Clips)	07AAJ-TG7A100	1
Metric Rotabroach Master Hole Cutting Kit	BLR11201SO	1
Rivet Gun/Installer	Has been auto-shipped to each dealer. The brand and model number may vary.	1
Deburring Tool	DEBUR300	1

## WARRANTY CLAIM INFORMATION

Operation Number	Description	Flat Rate Time	Defect Code	Symptom Code	Template ID	Failed Part Number
8120B1	Inspect the hood striker and spot weld(s).	0.3 hr	6FD00	PBV00	A21086A	60100-TG7-A90ZZ
8120B1A	Install striker plate only.	0.1 hr				
8120B1	Inspect the hood striker and spot weld(s).	0.3 hr	6FD00	PBV00	A21086B	60100-TG7-A90ZZ
8120B1A	Install striker plate only.	0.1 hr				
8120B1B	Do one spot weld repair - Add.	0.1 hr				
8120B1	Inspect the hood striker and spot weld(s).	0.3 hr	6FD00	PBV00	A21086C	60100-TG7-A90ZZ
8120B1A	Install striker plate only.	0.1 hr				
8120B1B	Do one spot weld repair - Add.	0.1 hr				
8120B1C	Do a second spot weld repair - Add.	0.1 hr				

### For Hood Replacement

8125A3	Dealer planning and DTC check (Includes hood striker and spot weld(s) inspection.	0.9 hr	6FD00	PBV00	A21086D	60100-TG7-A90ZZ
--------	---	--------	-------	-------	---------	-----------------

#### NOTE:

- Make sure your claim includes clear photos. Refer to Service Bulletin 10-002, *Photos for Warranty Paint Repair Claims*. Take clear photos showing the cracked areas of the hood and provide close-ups as needed to illustrate the defect. Take and submit a photo of the door jamb label that shows the VIN with the warranty claim.
- Upload a copy of the Honda and Acura Certified Collision Repair Shop final invoice with the warranty claim prior to submittal.

## INSPECTION PROCEDURE A

1. Park the vehicle on a level surface and set the parking brake.
2. Open the hood, then mount the support rod in the hood for support.
3. Inspect the hood striker area for cracks.
  - If there are no cracks, go to INSPECTION PROCEDURE B.
  - If there are cracks, go to Step 4.
4. Install the inspection template onto the hood striker as shown, then use a permanent marker to trace the areas around each striker mounting bolt.

**BEFORE**

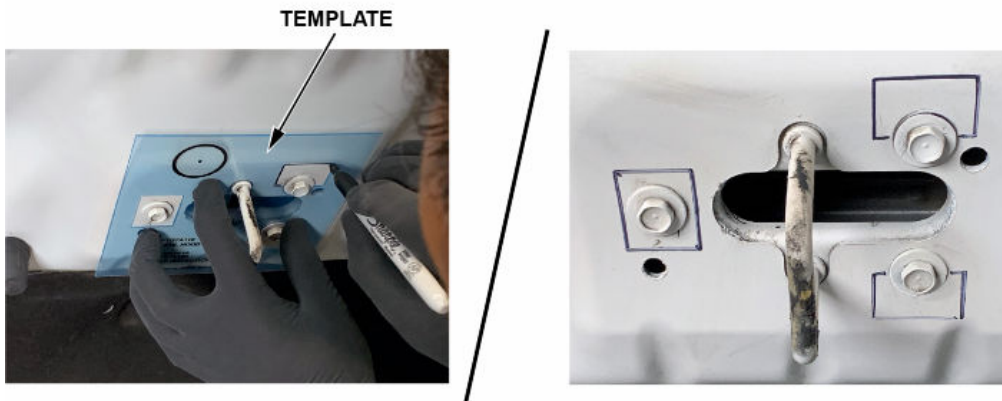

5. Remove the template, then visually inspect the length and location of the crack(s).
  - If the crack(s) are within or touching the lines you traced, go to INSPECTION PROCEDURE B.
  - If the crack(s) are beyond or outside the lines you traced, go to REPAIR PROCEDURE C.

## INSPECTION PROCEDURE B

1. Locate the 2 spot welds on the hood frame as shown.

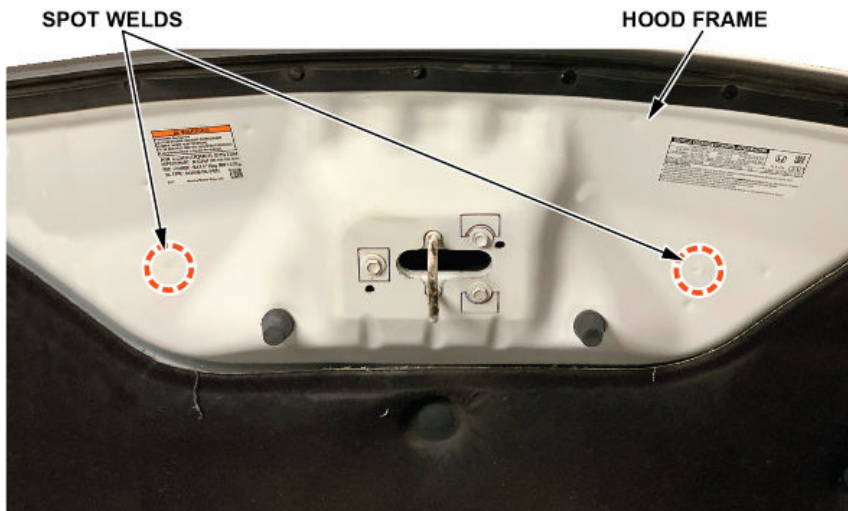

2. Inspect for a crack(s) at each spot weld.
  - If no crack(s) are present, go to REPAIR PROCEDURE A.
  - If there is full separation at the spot weld, go to REPAIR PROCEDURE C.

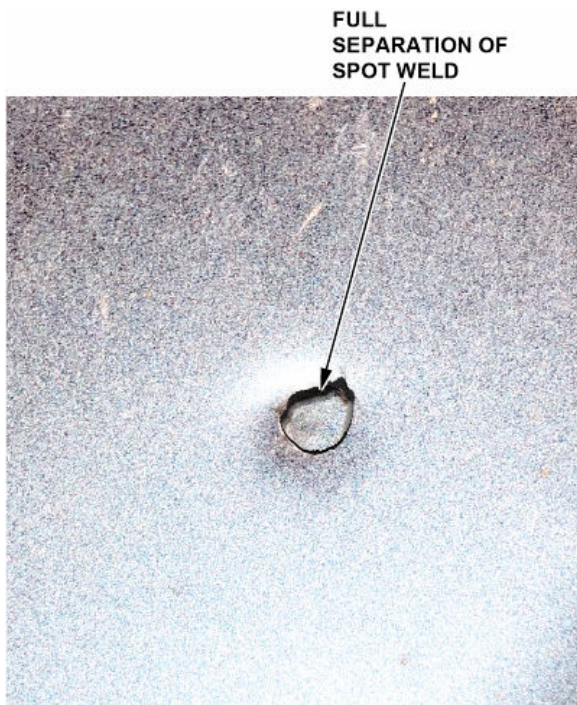

- If a crack(s) are present, but the spot weld hasn't fully separated, go to step 3.
3. Use the spot weld inspection circle on the inspection template to determine a pass/fail condition.

4. Align the center mark of the template with the center-point of the spot weld.

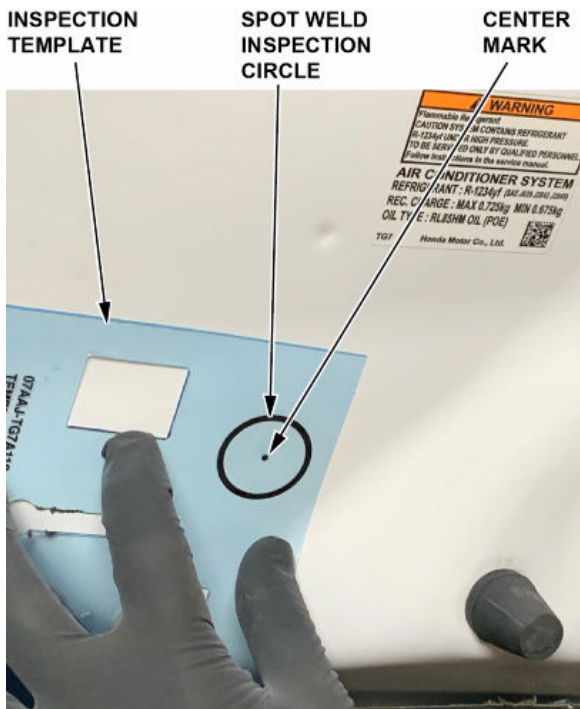

- If the length of the crack(s) are within the spot weld inspection circle, go to REPAIR PROCEDURE B, followed by REPAIR PROCEDURE A.

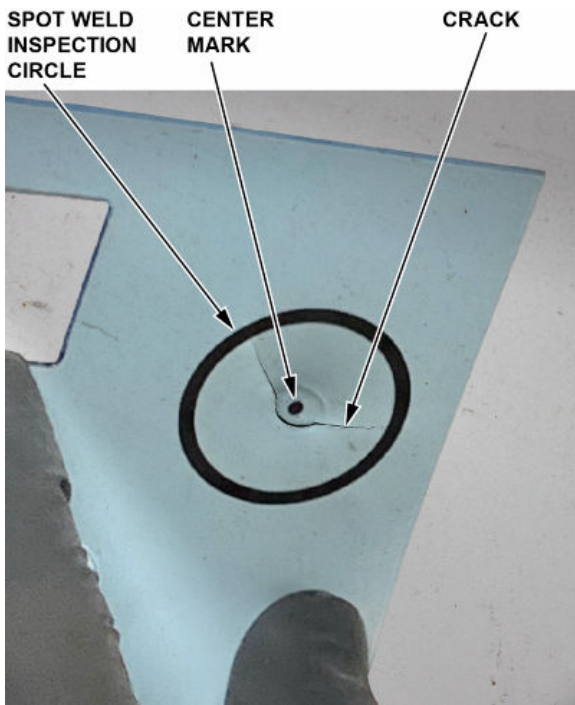

- If the length of the crack(s) are beyond the spot weld inspection circle, go to REPAIR PROCEDURE C.

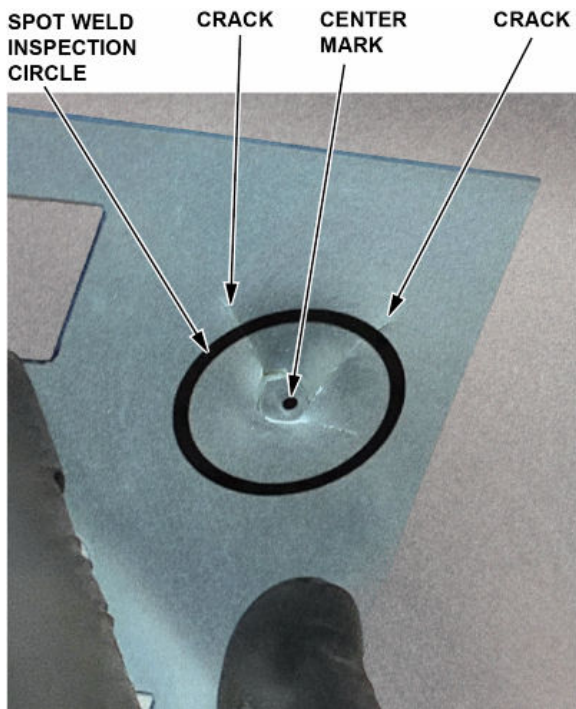

## REPAIR PROCEDURE A

1. Remove and discard the 3 bolts securing the striker to the hood frame.

**M6 BOLTS (3)**

Do not reuse.



2. Position the striker plate onto the hood frame and temporarily install the 2 fender clips supplied with the template kit to align the hood striker and the striker plate.

**STRIKER PLATE**

**FENDER CLIPS (2)**





3. Thread 2 of the new bolts into the striker plate until they are snug, then remove the 2 fender clips. Thread the remaining bolt and torque the bolts to **10.8 N.m (8 lb-ft)**.

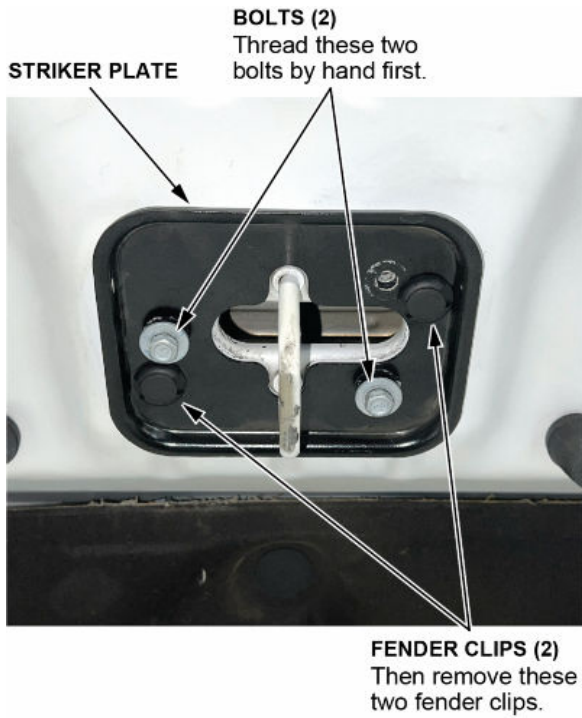

**M6 BOLTS (3)**  
10.8 N-m (8 lb-ft)



## REPAIR PROCEDURE B

1. Mark the center point of the spot weld using a center punch.

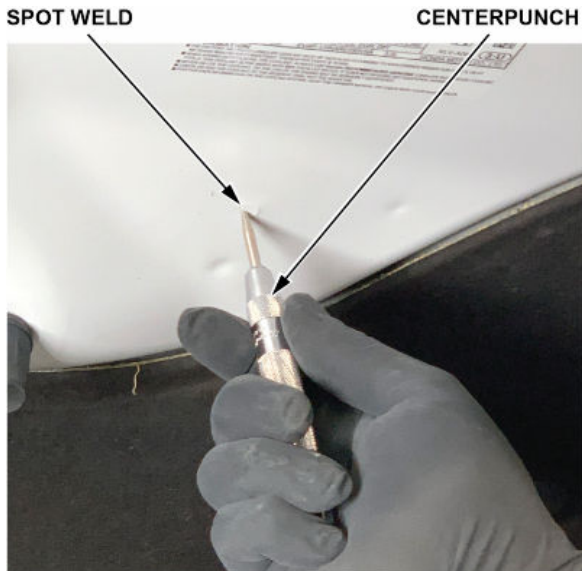

2. Drill the spot weld using a **7mm** Rotabroach bit, then remove any metal shavings or burrs using the Deburring Tool.  
NOTE: Place a suitable cover over the engine bay to catch any metal shavings to prevent them from falling into the engine bay.



DEBURRING TOOL



3. Install the mandrel end of the rivet into the Riveting Tool.



4. Place the supplied washer onto the rivet body, then insert the rivet into the hole you made on the hood.



5. Use one hand to support the hood, then push firmly with the rivet in place. Squeeze the tool/trigger to fasten the rivet.



NOTE: Do not use the tool in the conditions shown below. Doing so causes incorrect fastening.

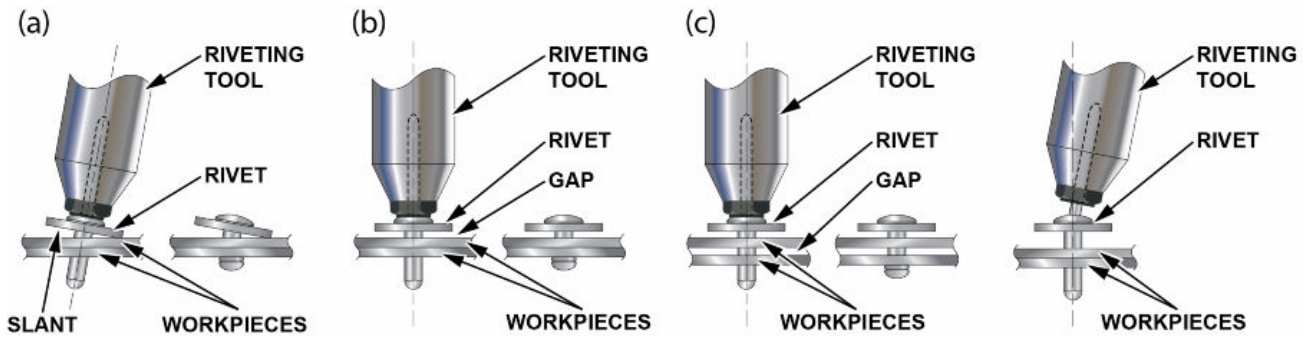

## REPAIR PROCEDURE C

### NOTE:

- All work must be completed by a Honda and Acura Certified Collision Repair Shop.
  - Refer to Service Bulletin 16-065, *Material Requirements for Warranty and Goodwill Paint Repairs*, for a list of approved paints and materials that must be used for warranty repairs.
  - Give your warranty clerk the Honda and Acura Certified Collision Repair Shop receipt. For the warranty claim to be paid, a copy of the Honda and Acura Certified Collision Repair Shop invoice must be included in the warranty claim.
1. Have a new replacement hood installed and refinished by a Honda and Acura Certified Collision Repair Shop.
  2. Remove the hood insulator from the original hood.

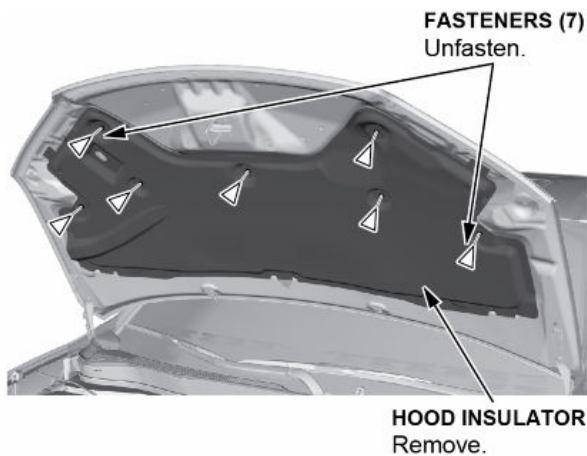

3. Remove the hood seal.

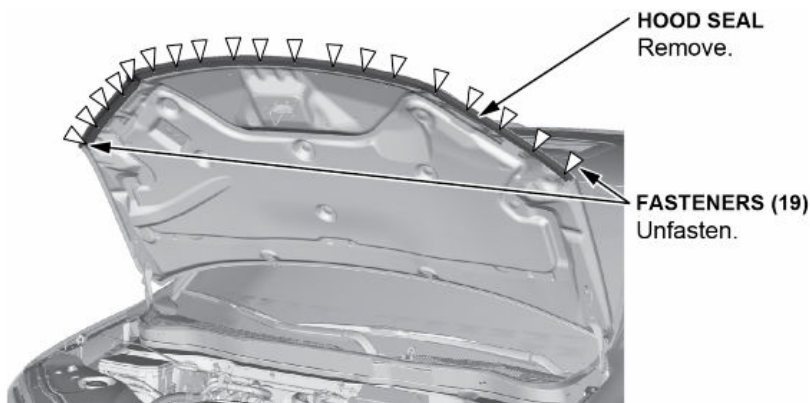

4. Install the hood insulator.

NOTE: Replace the insulator if it is torn/missing sections and replace any stressed or damaged clips.

5. Install the hood seal.

NOTE: Replace the hood seal if it is torn/missing sections and replace any stressed or damaged clips.

6. Do the following steps to adjust the hood:

- Slightly loosen the hood hinge mounting bolts and the hood latch mounting bolts.
- Adjust the hood alignment in the following sequence.
- Adjust the hood right and left, as well as forward and rearward, by using the elongated holes in the hood hinges.
- Turn the hood edge cushions, in or out as necessary, making sure the hood fit flush with the body at the front and side edges.

- Adjust the hood latch to obtain the proper height at the forward edge, and move the latch right or left until the striker is centered in the latch.
- Tighten each bolt to the specified torque.
- Check that the hood opens properly and closes securely.
- Inspect the resting position of the hood seal. Ensure that the hood seal is making contact along the front grille.
- Apply touch-up paint to the hinge mounting bolts and around the hinges, and let the paint dry.

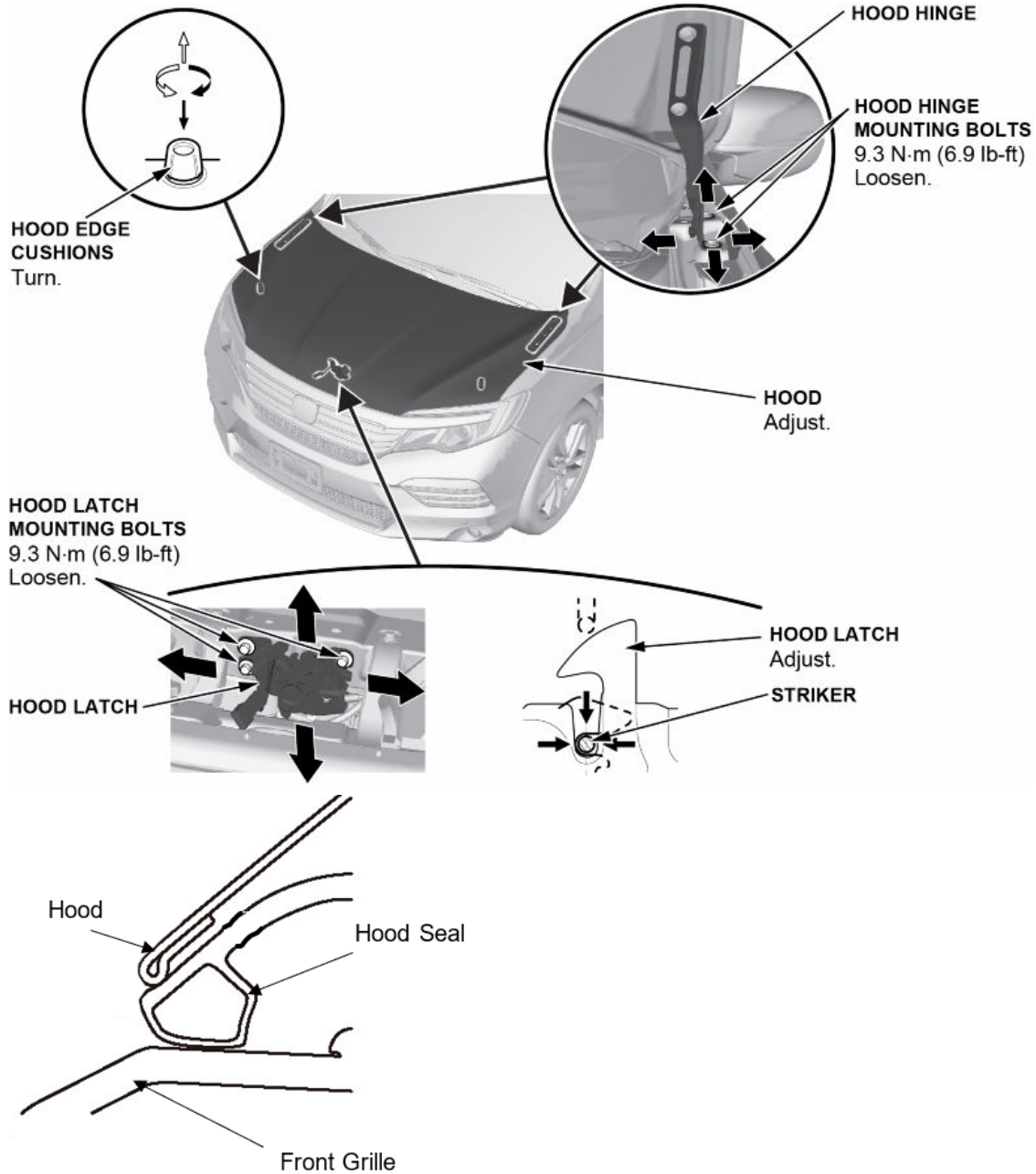

7. Apply multipurpose grease to the hood latch and the hood hinges as indicated by the arrows.

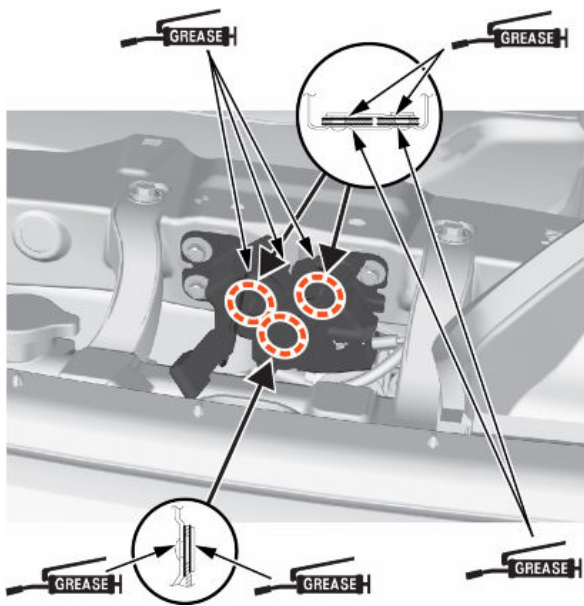

8. Apply new labels as shown and in the following locations.

- Air Conditioner Label.
- Emission Label.

**AIR CONDITIONER LABEL**

**EMISSION LABEL**





## **EMISSION LABEL ORDERING INFORMATION**

The controlled Parts Order screen in the iN is used to order emission labels. To order, you are required to supply the VIN, the vehicle owner's first and last name, and the name of a contact person at your dealership. It is very important that the VIN and other information be accurate. This information forms the basis for locating customers should it become necessary to do so in the future.

Vehicle Application: Under no circumstances may an emission label be installed on any vehicle other than the one whose VIN is indicated in the order. Emission labels that are ordered but not installed must be returned to AHM. Refer to the "Controlled Parts Return Policy" section in the Parts System Guide. Failure to follow this directive could subject the dealer to enforcement activity and fines.

Required Information: Orders for emission labels must include the customer's first and last name and the vehicle's complete VIN. A part number is not required when ordering emission labels. The correct label will be issued automatically based on the VIN.

END