



Revision 2 February 2023

Dealer Service Instructions for:

Safety Recall Y73 / NHTSA 21V-842

Rear Spoiler

NOTE: An additional post repair inspection has been added, along with updated LOP times.

Remedy Available

2021 (WD) Dodge Durango

NOTE: Some vehicles above may have been identified as not involved in this recall and therefore have been excluded from this recall.

IMPORTANT: Some of the involved vehicles may be in dealer new vehicle inventory. Federal law requires you to complete this recall service on these vehicles before retail delivery. Dealers should also consider this requirement to apply to used vehicle inventory and should perform this recall on vehicles in for service. Involved vehicles can be determined by using the VIP inquiry process.

Subject

The rear spoiler on about 4,830 of the above vehicles may be over-flush to the roof, allowing contact to the roof when cycling the liftgate. Vehicle occupants may hear the spoiler hitting the body when opening or closing the liftgate, or a rattle from the spoiler being loose while driving. An over-flush rear spoiler may become damaged when cycling the liftgate which may result in the spoiler becoming partially detached from the vehicle. Rear spoilers that become partially detached may separate from the vehicle while driving, potentially creating a road hazard to

operators and occupants of other vehicles, and can cause such vehicles to crash without prior warning.

Repair

The rear spoiler will be inspected for looseness and gaps that indicate it may not have been installed properly. If needed, the upper spoiler section will be replaced, and the spoiler reattached to the vehicle.

Alternate Transportation

Dealers should attempt to minimize customer inconvenience by placing the owner in a loaner vehicle if inspection determines that spoiler replacement is required and the vehicle must be held overnight.

Parts Information

<u>Part Number</u>	<u>Description</u>
CSANY731AA	Rear Spoiler, Standard

Each package contains the following components:

<u>Quantity</u>	<u>Description</u>
1	Rear Spoiler, Standard

OR

<u>Part Number</u>	<u>Description</u>
CSANY732AA	Rear Spoiler, SRT, Hellcat and Pursuit

Each package contains the following components:

<u>Quantity</u>	<u>Description</u>
1	Rear Spoiler, SRT, Hellcat and Pursuit

<u>Part Number</u>	<u>Qty.</u>	<u>Description</u>
68087885AA	4	Pin Clip, Lower Liftgate (MSQ 4), both spoiler types

Parts Return

No parts return required for this campaign.

Special Tools

The following special tool is required to perform this repair:

- C-4755 Trim Stick

Service Procedure

A. Inspect

1. Grasp the rear spoiler with one hand and gently push to feel for loose fasteners. After feeling for looseness, release the spoiler, and check the gap between the spoiler and the hatch glass on each side of the spoiler in line with the roof rack. If the gap is greater than 5mm, the upper spoiler must be replaced (Figure 1).

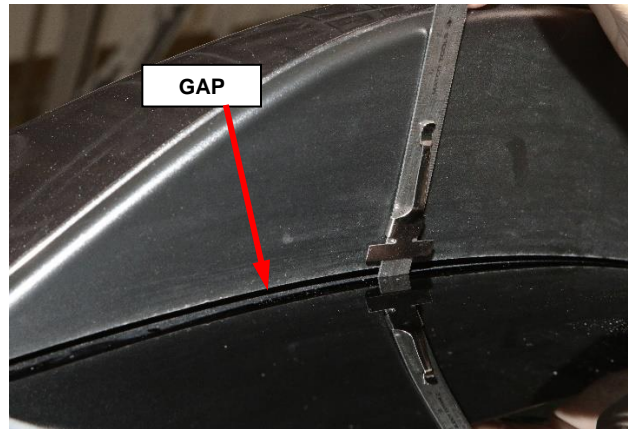

Figure 1 – Gap to Glass Inspection

2. Rest a small straight edge (like to driver license or credit card) on the roof and check for flushness of the liftgate. Check at the center (behind the antennae), and at each end. The spoiler must not be more than 1mm over flush to the body. If it is, the upper spoiler must be replaced (Figure 2).

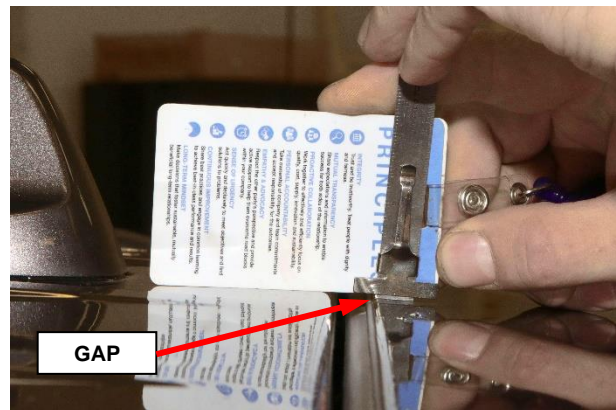

Figure 2 – Flushness of Spoiler to Roof

Service Procedure [Continued]

3. Measure the gap between the spoiler and roof on the right and left ends. This gap must be 6mm or greater. If not, the upper spoiler must be replaced (Figures 3 and 4).



Figure 3 – Gap from Spoiler to Roof

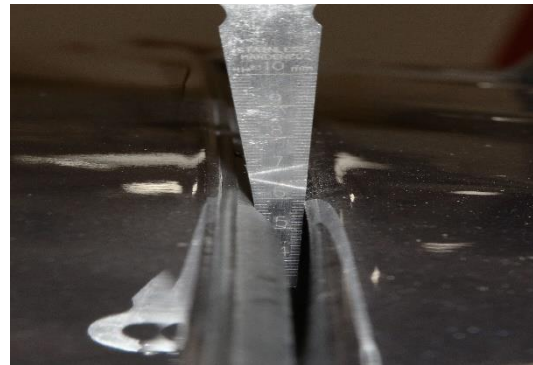

Figure 4 – Gap from Spoiler to Roof

4. Visually inspect the lip seal. The seal must be sitting tight to the spoiler and not catching on the roof. The seal must not be distorted. If the seal does not pass inspection, the upper spoiler must be replaced (Figure 5).



Good



Bad

Figure 5 – Lip Seal Inspection

Service Procedure [Continued]

5. With the help of an assistant, open the liftgate while looking cross-car to ensure the spoiler seal does not hang up on the roof. Close the gate while making the same inspection. Repeat several times, while inspecting from both sides of the vehicle. A slight brush condition is acceptable. If the seal gets hung up, the upper spoiler must be replaced (Figure 6).



Good



Bad

Figure 6 – Lip Seal Clearance Inspection

NOTE: If any one of the five inspection criteria above do not meet requirements, the rear spoiler must be replaced. If all five inspection criteria are met, the recall can be marked complete and the vehicle returned to the customer.

Service Procedure [Continued]

B. Remove

1. Move the passenger seat forward.
2. Disconnect and isolate the negative battery cable. If equipped with an Intelligent Battery Sensor (IBS), disconnect the IBS connector first before disconnecting the negative battery cable.
3. Open the liftgate.
4. Remove the header trim (Figure 7).
4. Disconnect the electrical connector to the courtesy light, if equipped.



Figure 7 – Header Trim

5. Disconnect the washer solvent supply hose and the CHMSL electrical connector (Figure 8).

NOTE: Use a bucket to catch any fluid that may drip from the washer solvent supply hose.

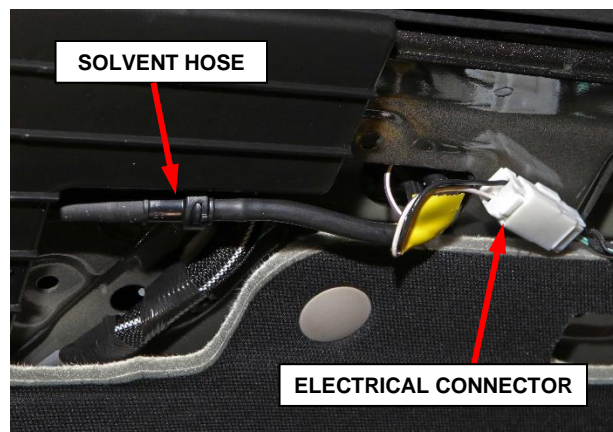

Figure 8 – Washer Solvent Hose and Electrical Connector

Service Procedure [Continued]

6. Press down on the pull cup on the liftgate trim (Figure 9).
7. Using a Trim Stick C-4755 or equivalent, at the top in the center, release the cup from the trim panel (Figure 9).



Figure 9 – Liftgate Pull Cup

8. Remove the two pull cups (1) from the lower trim panel (Figure 10).

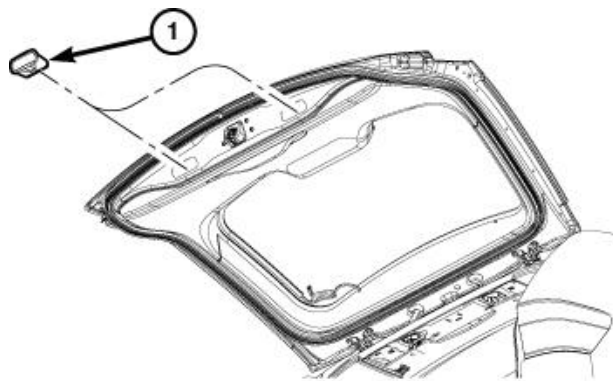

3656814

Figure 10 – Liftgate Pull Cups

Service Procedure [Continued]

9. Using a Trim Stick C-4755 or equivalent, release the six lower retaining clips (3) and carefully pry the trim panel (1) away from the inside of the liftgate (4) (Figure 11).

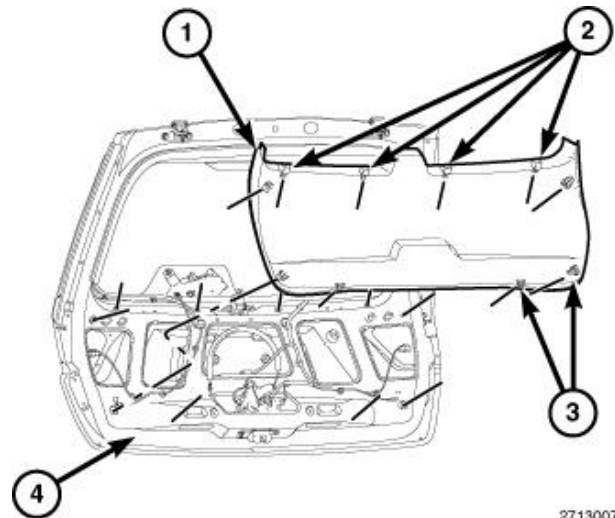

2713007

Figure 11 – Lower Liftgate Trim Panel

10. Carefully release the upper retaining clips (2) and separate the trim panel completely from the liftgate (Figure 11).

11. Disconnect the trim panel lighting connectors.

12. Remove the lower liftgate trim panel from the vehicle.

CAUTION: Green trim panel attachment clips should be discarded and replaced with new ones anytime the trim is removed.

13. Remove the upper trim panel (2) using a Trim Stick C-4755 or equivalent, carefully pry the trim panel away from the inside of the liftgate (1) to release the fasteners that secure the panel to the liftgate (Figure 12).

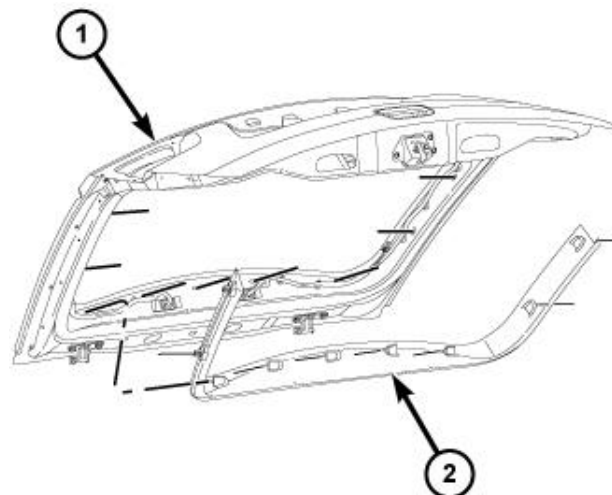

2713048

Figure 12 – Upper Liftgate Trim Panel

Service Procedure [Continued]

- 14. Remove the four spoiler mounting nuts (1) (Figure 13).

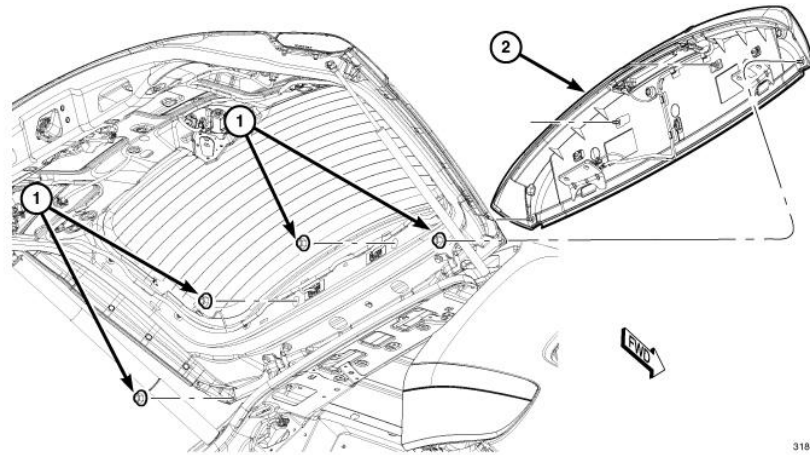

Figure 13 – Spoiler Attachments

- 15. Remove the rubber body plug from the liftgate (Figure 14).

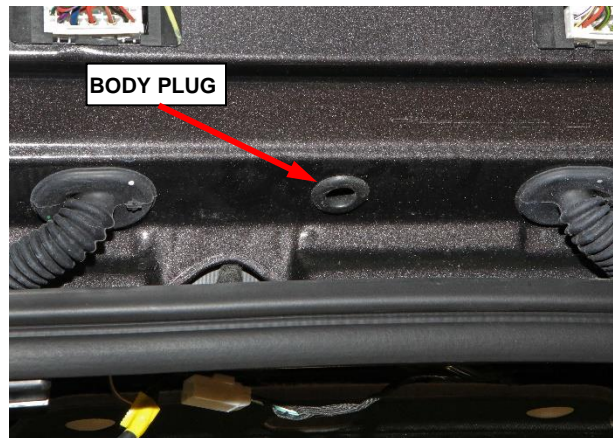

Figure 14 – Rubber Body Plug

- 16. Squeeze the plastic w-clip retainer tabs with a 7 or 8mm socket (1) through access hole to release spoiler (Figure 15).

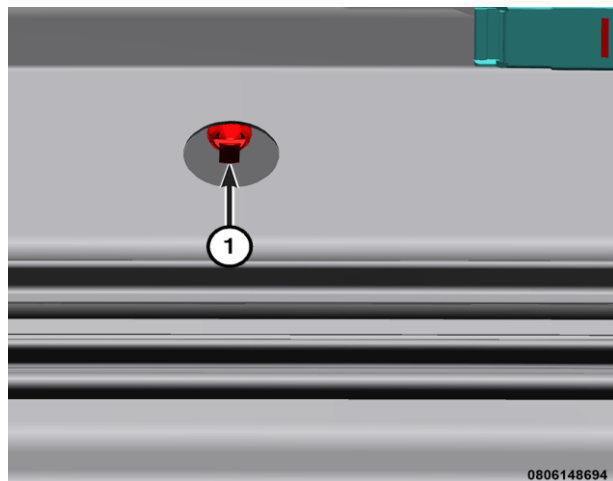

Figure 15 – Spoiler Retainer Clips

Service Procedure [Continued]

17. Lower the liftgate.

Note: Do not try to separate Spoiler until hidden W clip is released or clip may be damaged (Step 16).

18. With a helper, pivot the spoiler (2) towards the front of the vehicle (Figure 13).

19. Remove spoiler from vehicle.

20. Inspect the w-clip hole in the sheet metal to assure they are flush. If removing the spoiler pulled this surface up, flatten it back with a soft mallet. If the grommet stayed on the body when the spoiler was removed, transfer it to the new spoiler.

C. Paint new Upper Spoiler

1. Paint the new replacement upper spoiler per the approved warranty refinish paint manufacturers (Akzo Nobel, Axalta, BASF, PPG, and Sherwin-Williams) recommendations.

Service Procedure [Continued]

D. Transfer Components

1. Remove five round, reusable clips holding the upper and lower spoiler together (Figure 16).

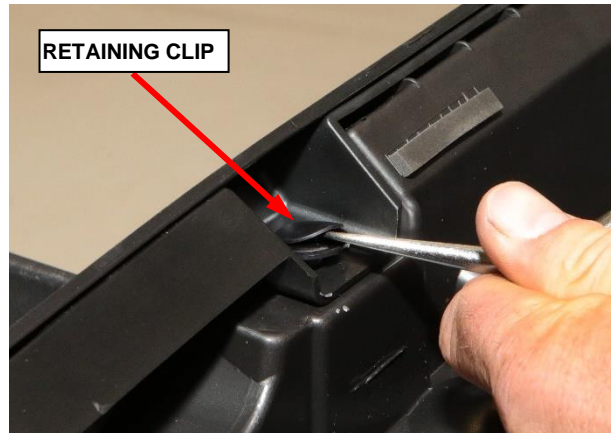

Figure 16 – Spoiler Half Retaining Clips

2. Using trim stick C-4755 or equivalent, at each end of the spoiler, and working from the back of the spoiler, release the tabs holding the upper and lower spoiler together (Figure 17).

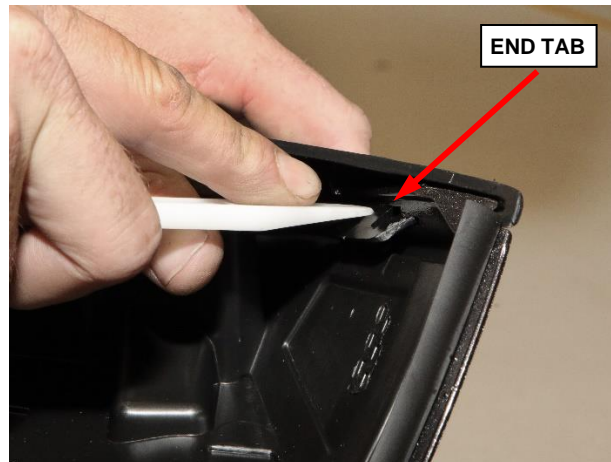

Figure 17 – Release End Tabs

Service Procedure [Continued]

3. Release eight additional tabs by gently pulling the two spoiler halves apart (Figure 18).



Figure 18 – Release Center Tabs

6. Remove two screws holding CHMSL lens to the upper spoiler (Figure 19).
7. Remove the CHMSL lens and wiring from the spoiler. Transfer the CHMSL nuts to the new spoiler.

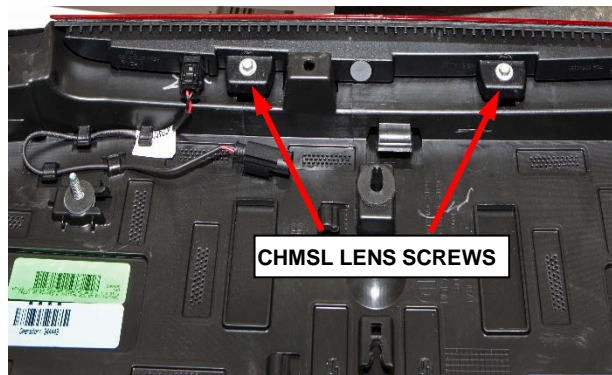

Figure 19 – CHMSL Lens Screws

8. Working on a padded surface to protect the paint, install the CHMSL lens and harness to the new spoiler upper.
9. Install the two screws holding the CHMSL to the upper spoiler (Figure 19).
10. Transfer the center W clip, and the four T studs (the two center studs are larger, the outer studs are smaller) from the old spoiler to the new.

Service Procedure [Continued]

11. Assemble the original lower spoiler to the new painted upper spoiler, beginning with the 8 center most tabs (Figure 19).
12. Seat the tabs at each end of the spoiler.
13. Install the five round, reusable clips holding the upper and lower spoiler together (Figure 16).
14. Install the new adhesive end seals to the spoiler right and left ends (Figure 20).



Figure 20 – Spoiler End Seals

15. Install the new lip seal to the channel on back edge of the upper spoiler. Compare to the old part for proper orientation (Figure 21).



Figure 21 – Spoiler Lip Seal

Service Procedure [Continued]**E. Install**

1. With a helper, lift spoiler (2) into place and pivot towards the front of the vehicle (Figure 13).
2. Feed the washer solvent hose and electrical connectors through their access hole in vehicle.
3. Lower spoiler into position and engage retainer w-clip (Figure 10).
4. Verify that the end seals are not pinched under the spoiler.
5. Place the grommet over the w-clip.
6. Install washer rubber body plug (Figure 9).
7. Install the nuts (1) tighten to the 5 N·m (44 in. lbs.) (Figure 8).
8. Using hand pressure, press firmly and evenly on the upper trim panel (2) over each of the fastener locations until the fasteners are fully engaged in the holes on the inside of the liftgate (1) (Figure 12).
9. Install new green lower trim panel attachment clips to the lower liftgate trim and verify they are properly installed.
10. Connect the lighting connector (Figure 8).
11. Position the top edge of the lower liftgate trim (1) onto the liftgate and seat the upper retaining clips (2) fully (Figure 11).
12. Using hand pressure, press firmly and evenly on the lower trim panel (1) over each of the six lower retaining clip locations (3) until the clips are seated fully in the holes on the inside of the liftgate (Figure 11).

Service Procedure [Continued]

13. Install the pull cups (2) in the lower trim (1) and seat the clips (3) fully (Figure 22).
14. Connect the negative battery cable.
15. Repeat **A. Inspect steps 1-5** to verify that the spoiler now passes inspection.
16. **If inspection in Step 15 fails, adjust the liftgate to achieve specified minimum gap and flush conditions specified in A. Inspect steps 2 & 3. See Service Library 23 - Body / Decklid/Hatch/Liftgate/Tailgate/Swing Gate / LIFTGATE / Adjustments.**

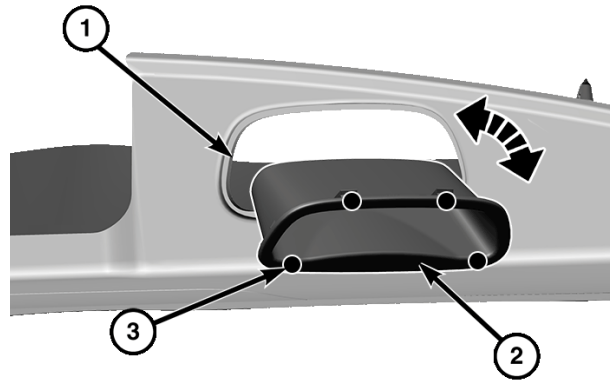

2309184649

Figure 22 – Upper Trim Pull Cup Install

Completion Reporting and Reimbursement

Claims for vehicles that have been serviced must be submitted on the DealerCONNECT Claim Entry Screen located on the Service tab. Claims paid will be used by FCA to record recall service completions and provide dealer payments.

Use the following labor operation numbers and time allowances:

	<u>Labor Operation Number</u>	<u>Time Allowance</u>
Inspect Rear Spoiler	23-Y7-31-81	0.2 hours
Inspect and Replace Rear Spoiler	23-Y7-31-82	0.9 hours
 <u>Related Operation</u>		
Paint / Finish New Spoiler	23-Y7-31-50	1.6 hours
Adjust Tailgate	23-Y7-31-51	0.3 hours
 Floor Plan Reimbursement	 95-95-95-97	 Calculate See Below

Floor Plan Reimbursement represents the vehicle’s average daily allowance (see table below) multiplied by the number of days the vehicle was in dealer inventory and not available for sale. This reimbursement is limited to the number of days from the date of the stop sale to the date that the remedy was made available. Note: If the vehicle was received by your dealership (KZX date) AFTER the stop sale date, you will use the KZX date instead of the stop sale date. For this Recall, the stop sale was initiated on 11/04/2021 and the remedy was made available on 12/17/2021, therefore, the number of days cannot exceed 43 days.

Vehicle	Average Daily Allowance
2021 (WD) Dodge Durango	[REDACTED]

Add the cost of the recall parts package plus applicable dealer allowance to your claim.

NOTE: See the Warranty Administration Manual, Recall Claim Processing Section, for complete recall claim processing instructions.

Dealer Notification

To view this notification on DealerCONNECT, select “Global Recall System” on the Service tab, then click on the description of this notification.

Owner Notification and Service Scheduling

All involved vehicle owners known to FCA are being notified of the service requirement by first class mail. They are requested to schedule appointments for this service with their dealers. A generic copy of the owner letter is attached.

Vehicle Lists, Global Recall System, VIP and Dealer Follow Up

All involved vehicles have been entered into the DealerCONNECT Global Recall System (GRS) and Vehicle Information Plus (VIP) for dealer inquiry as needed.

GRS provides involved dealers with an updated VIN list of their incomplete vehicles. The owner’s name, address and phone number are listed if known. Completed vehicles are removed from GRS within several days of repair claim submission.

To use this system, click on the “**Service**” tab and then click on “**Global Recall System.**” Your dealer’s VIN list for each recall displayed can be sorted by: those vehicles that were unsold at recall launch, those with a phone number, city, zip code, or VIN sequence.

Dealers must perform this repair on all unsold vehicles before retail delivery. Dealers should also use the VIN list to follow up with all owners to schedule appointments for this repair.

Recall VIN lists may contain confidential, restricted owner name and address information that was obtained from the Department of Motor Vehicles of various states. Use of this information is permitted for this recall only and is strictly prohibited from all other use.

Additional Information

If you have any questions or need assistance in completing this action, please contact your Service and Parts District Manager.

Customer Services / Field Operations
FCA US LLC

This notice applies to your vehicle,

[Model Year and Model]

VIN XXXXXXXXXXXXXXXXXXXX

Y73/NHTSA 21V-842

LOGO

VEHICLE PICTURE

YOUR SCHEDULING OPTIONS

1. RECOMMENDED OPTION

Call your authorized Chrysler / Dodge / Jeep® / RAM Dealership.

2. Call the FCA Recall Assistance

Center at 1-800-853-1403. An agent can confirm part availability and help schedule an appointment

3. Visit recalls.mopar.com, scan the

QR code below, or download the Mopar Owner's Companion App.

QR Code

Get access to recall notifications, locate your nearest dealer, and more through this website or Mopar Owner's Companion App. You will be asked to provide your Vehicle Identification Number (VIN) to protect and verify your identity. The last eight characters of your VIN are provided above.

DEALERSHIP INSTRUCTIONS

Please reference Safety Recall Y73.

IMPORTANT SAFETY RECALL

Rear Spoiler

Dear [Name],

This notice is sent to you in accordance with the National Traffic and Motor Vehicle Safety Act.

FCA US has decided that a defect, which relates to motor vehicle safety, exists in certain [2021 (WD) Dodge Durango] vehicles.

It is extremely important to take steps now to repair your vehicle to ensure the safety of you and your passengers.

WHY DOES MY VEHICLE NEED REPAIRS?

The rear spoiler on your vehicle ^[1] may be over-flush to the roof, allowing contact to the roof when cycling the liftgate. Vehicle occupants may hear the spoiler hitting the body when opening or closing the liftgate, or a rattle from the spoiler being loose while driving. **Rear spoilers that become partially detached may separate from the vehicle while driving, potentially creating a road hazard to operators and occupants of other vehicles, and can cause such vehicles to crash without prior warning.**

HOW DO I RESOLVE THIS IMPORTANT SAFETY ISSUE?

FCA US will repair your vehicle ^[2] free of charge (parts and labor). To do this, your dealer will inspect and, if necessary, replace the rear spoiler. The estimated repair time is one hour. In addition, your dealer will require your vehicle for proper check-in, preparation, and check-out during your visit, which may require more time. Your time is important to us, so we recommend that you schedule a service appointment to minimize your inconvenience. Please bring this letter with you to your dealership.

**TO SCHEDULE YOUR FREE REPAIR,
CALL YOUR CHRYSLER, DODGE, JEEP OR RAM DEALER TODAY**

WHAT IF I ALREADY PAID TO HAVE THIS REPAIR COMPLETED?

If you have already experienced this specific condition and have paid to have it repaired, you may visit www.fcarecallreimbursement.com to submit your reimbursement request online. ^[3] Once we receive and verify the required documents, reimbursement will be sent to you within 60 days. If you have had previous repairs performed and/or already received reimbursement, you may still need to have the recall repair performed.

We apologize for any inconvenience, but are sincerely concerned about your safety. Thank you for your attention to this important matter.

Customer Assistance/Field Operations
FCA US LLC



Mr. Mrs. Customer
1234 Main Street
Hometown, MI 48371

[1] If you no longer own this vehicle, please help us update our records. Call the FCA Recall Assistance Center at 1-800-853-1403 to update your information.

[2] If your dealer fails or is unable to remedy this defect without charge and within a reasonable time, you may submit a written complaint to the Administrator, National Highway Traffic Safety Administration, 1200 New Jersey Ave., S.E., Washington, DC 20590, or you can call the toll-free Vehicle Safety Hotline at 1-888-327-4236 (TTY 1-800-424-9153), or go to safercar.gov.

[3] You can also mail in your original receipts and proof of payment to the following address for reimbursement consideration: FCA Customer Assistance, P.O. Box 21-8004, Auburn Hills, MI 48321-8007, Attention: Recall Reimbursement.

Note to lessors receiving this recall notice: Federal regulation requires that you forward this recall notice to the lessee within 10 days.