

SAFETY RECALL

SR21-85D

Date	Expiration	Group	No.	Page
08.2023	NA	3521	85	1(34)

Revision: D	ADDITION OF "FINAL STEP – FOG LIGHTS ACTING AS CORNERING LIGHTS "	July 2024
Revision: C	INSTRUCTION ENHANCED	February 2024
Revision: B	NO PRE-ASSEMBLY OF DOT COMPONENTS. DOT COMPONENTS REMOVED FROM THE KIT. TIME ALLOWANCE INCREASED.	February 2024

FRONT HEADLAMPS REPLACEMENT 9700 USCAN (B13R)

MODEL YEAR(S) AND VEHICLE SERIAL NUMBERS (VIN) INVOLVED

NOTICE TO SERVICE CENTERS <i>Verify vehicle eligibility by checking recall status with SAP or via ONLINE WARRANTY SYSTEM available on Service / Warranty tab of Prevest website.</i>	
Model	VIN
Volvo 9700 us/can Model Year: 2009 - 2021	
This recall does not necessarily apply to all the above-mentioned vehicles, some vehicles may have been modified before delivery. The owners of the vehicles affected by this recall will be advised by a letter indicating the Vehicle Identification Number (VIN) of each vehicle concerned.	

Table of contents

DESCRIPTION.....	2
VEHICLE GROUP	2
MATERIAL.....	3
For group 1,2 & 3 vehicles.....	3
For group 1 vehicles only	3
SOFTWARE	3
For group 2 & 3 vehicles.....	3
PROCEDURE	4
PRELIMINARY WORK	4
GROUPE 1, 2 & 3 VEHICLES - HEADLAMPS ASSEMBLY	4
LOW BEAM LED INSTALLATION	5
HIGH BEAM LED INSTALLATION.....	8
TURN SIGNAL INSTALLATION.....	10
HARNESSE INSTALLATION.....	12
GROUPE 1, 2 & 3 VEHICLES - HEADLAMPS REMOVAL & INSTALLATION	14
GROUPE 1 VEHICLES ONLY - RESISTOR HARNESSE INSTALLATION	24

SAFETY RECALL

SR21-85D

Date	Expiration	Group	No.	Page
08.2023	NA	3521	85	2(34)

GRUPE 1, 2 & 3 VEHICLES - HEADLAMPS AIMING INSTRUCTION	26
Low Beam Adjustment	26
High Beam Adjustment.....	29
GRUPE 2 & 3 VEHICLES - SOFTWARE UPDATE	31
GRUPE 1 VEHICLES ONLY - PARAMETER UPDATE	32
FINAL STEP – FOG LIGHTS ACTING AS CORNERING LIGHTS	33
PARTS / WASTE DISPOSAL.....	34
WARRANTY.....	34

DESCRIPTION

On the vehicles affected by this recall, replace both headlamp assemblies and then perform the software or parameters update.

VEHICLE GROUP

Group 1

Volvo 9700 equipped with LCM #20815236
VIN 3CET2M62795127142 (2009) up to 3CET2S226D5158966 (2013)

Group 2

Volvo 9700 equipped with SCLM08 #21043962
VIN 3CET2S222D5159595 (2013) to 3CET2V928J5191373 (2018)

Group3

Volvo 9700 equipped with SLCM 2.0 #23297154
VIN 3CET2V923J5191913 (2018) to 3CET2W425L5202572 (2020)

SAFETY RECALL

SR21-85D

Date	Expiration	Group	No.	Page
08.2023	NA	3521	85	3(34)

MATERIAL

For group 1,2 & 3 vehicles

Order kit **SR21-85** which includes the following parts:

Part No.	Description	Qty
7775331	HEADLAMP BEZEL RH ASSY (wiring harness pre-installed)	1
7775332	HEADLAMP BEZEL LH ASSY (wiring harness pre-installed)	1

Also, order the following parts:

Part No.	Description	Qty
24219713-NS	LAMP,4" TURN/PARK SIGNAL	2
24224437-NS	HEADLAMP, HIGH BEAM LED 90 mm	2
24224438-NS	HEADLAMP, LOW BEAM LED 90 mm	2

For group 1 vehicles only

Order kit **SR21-85-2** which includes the following parts:

Part No.	Description	Qty
7775321	WIRING HARNESS W/RESISTORS	1
500798	SCREW TP PAN PH Z050 #4-3/8	4

SOFTWARE

For group 2 & 3 vehicles

Software required:

Part No.	Description	Qty
24252354	CONVERSION KIT, SLCM PARAMETERS.	1

PROCEDURE

DANGER

Park vehicle safely, apply parking brake, stop the engine. In the battery box, set the battery cut-off switch to the OFF position prior to working on the vehicle.

Lockout & Tag out (LOTO) must be performed during set-up, maintenance or repair activities. Refer to your local procedure for detailed information regarding the control of hazardous energy.

PRELIMINARY WORK

Validate that the headlights, turn signals and fog lamps are functioning normally. Correct any lighting problems before initiating this bulletin.

GROUPE 1, 2 & 3 VEHICLES - HEADLAMPS ASSEMBLY

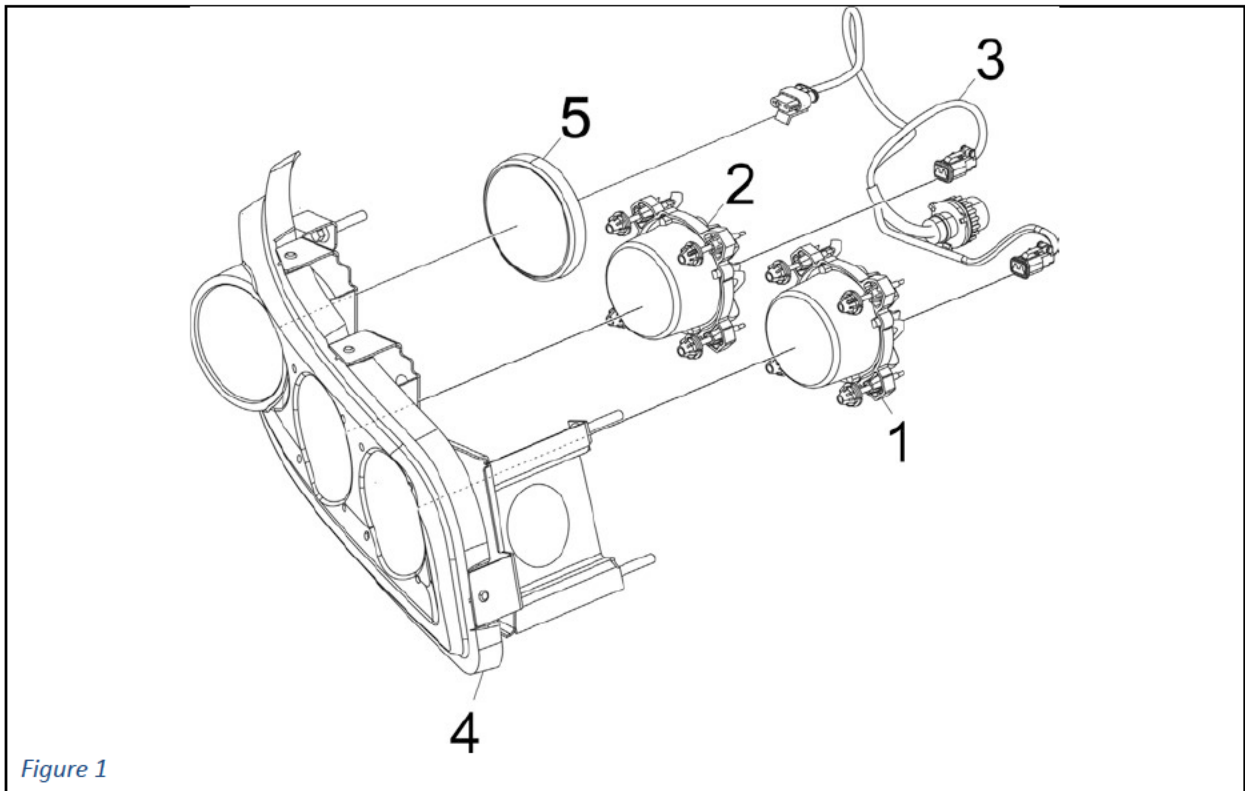

Item	Part number	Description
1	24224437-NS	HIGH BEAM LED 90 mm (<i>stamped with "8458"</i>)
2	24224438-NS	LOW BEAM LED 90 mm (<i>stamped with "8459"</i>)
3	-	WIRING HARNESS, FRONT LIGHT
4	7775331	HEADLAMP BEZEL RH
4	7775332	HEADLAMP BEZEL LH

SAFETY RECALL

SR21-85D

Date	Expiration	Group	No.	Page
08.2023	NA	3521	85	5(34)

5	24219713-NS	LAMP,4" TURN/PARK SIGNAL
---	-------------	--------------------------

LOW BEAM LED INSTALLATION

- 1) LOW BEAM LED p/n 24224438-NS stamped with "8459" (item 2, Figure 1). Insert adjuster screws in mounting bracket from back with ball facing front and side labeled "top" facing up. Press in by hand until adjuster snaps into housing.

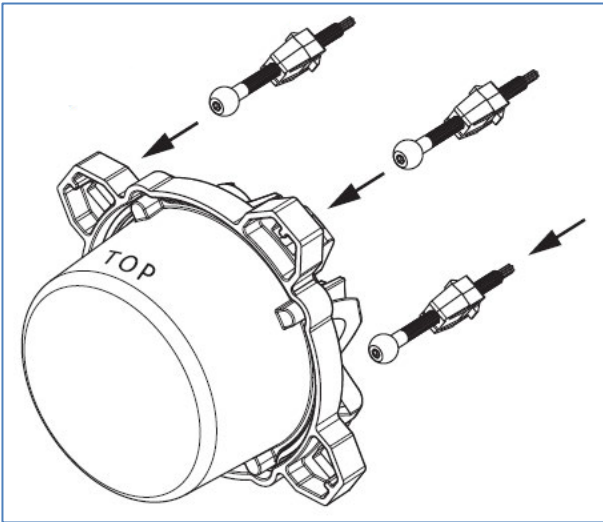

Figure 2



Figure 3: stamped with "8459"

- 2) Snap low beam clips into mounting holes on RH & LH headlamp bezel (item 4, Figure 1)

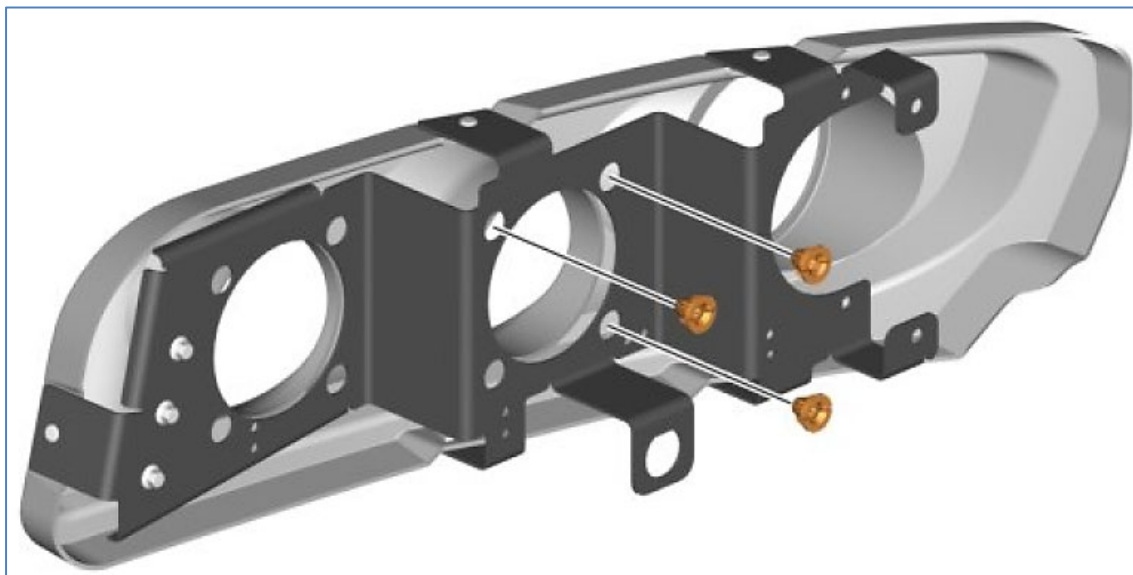

Figure 4: RH headlamp shown

SAFETY RECALL

SR21-85D

Date	Expiration	Group	No.	Page
08.2023	NA	3521	85	6(34)

- 3) Press adjuster balls into clips. The TOP inscription on the lens should be placed at the top, so the connector is at the bottom.

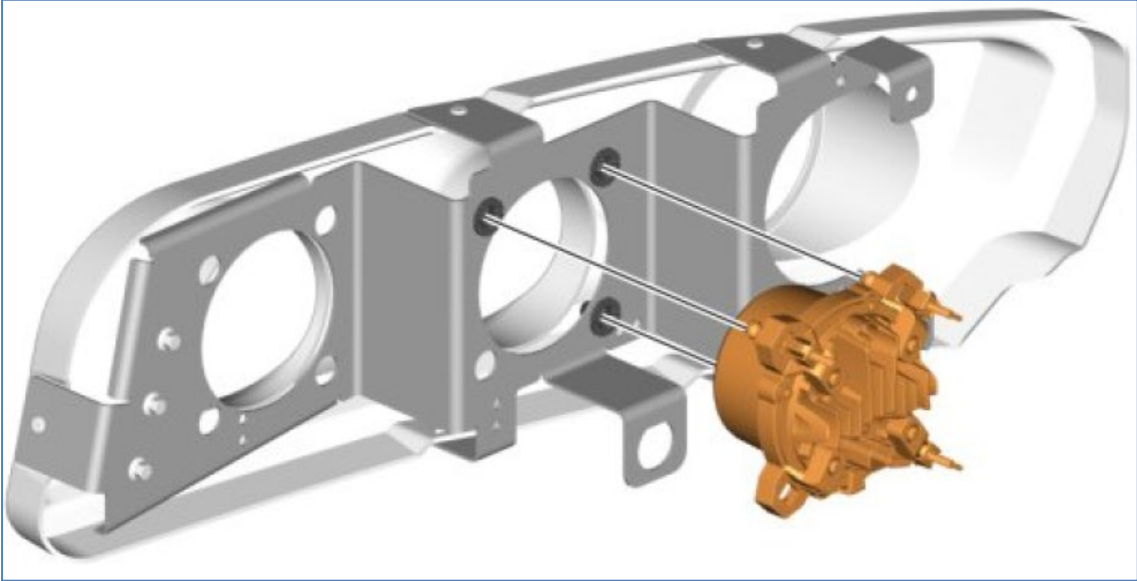

Figure 5: RH headlamp shown

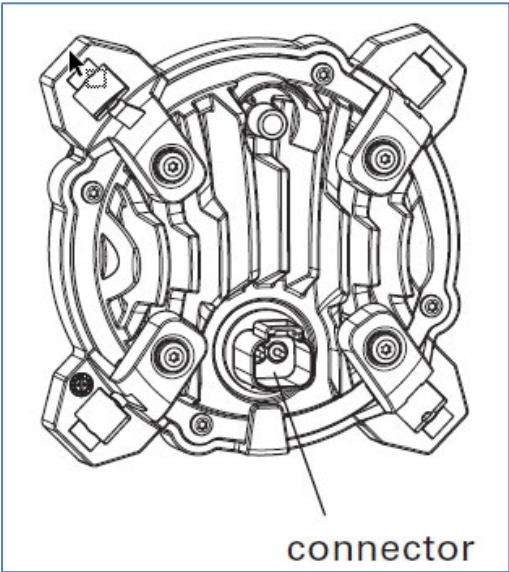

Figure 6: CONNECTOR AT THE BOTTOM

SAFETY RECALL

SR21-85D

Date	Expiration	Group	No.	Page
08.2023	NA	3521	85	7(34)

- 4) Adjust the four (4) screws until the beam mounting bracket is **10 mm** from panel.

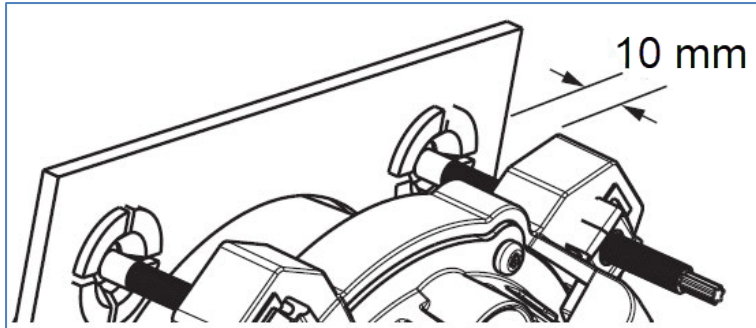

Figure 7

- 5) Plug the low beam connector labelled **E02**.

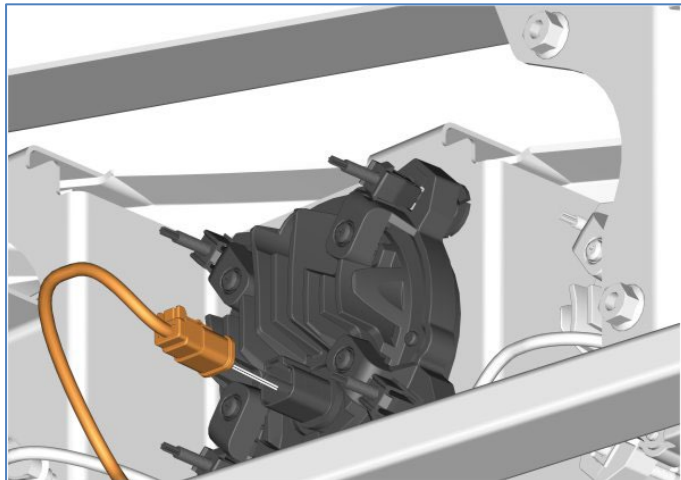

Figure 8

Date	Expiration	Group	No.	Page
08.2023	NA	3521	85	8(34)

HIGH BEAM LED INSTALLATION

- 1) Proceed similarly with the high beam p/n 24224437-NS stamped with "8458" (item 1, Figure 1).



Figure 9: stamped with "8458"

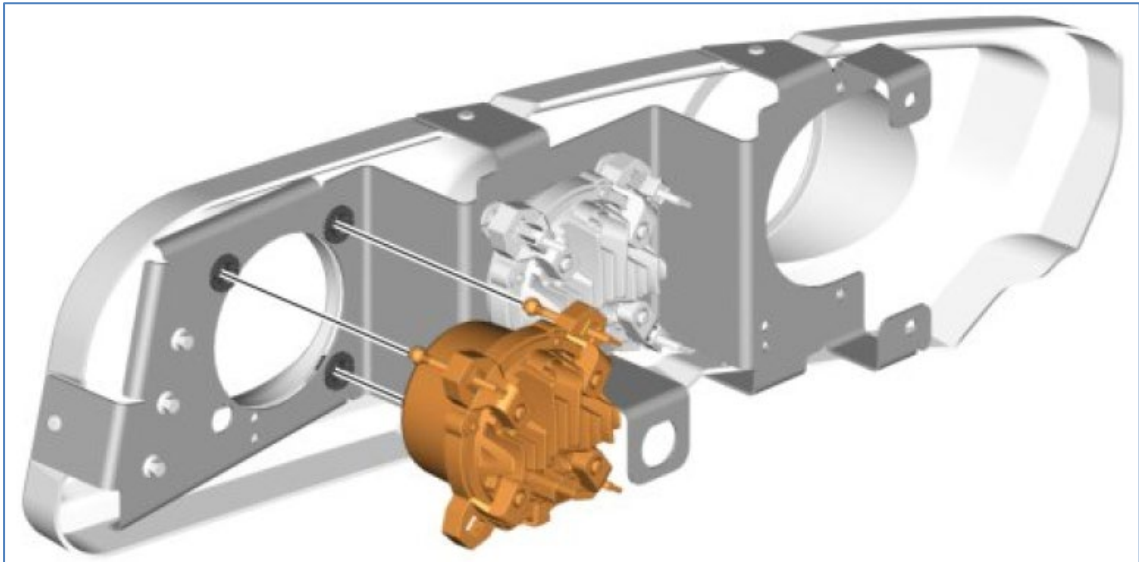

Figure 10

SAFETY RECALL

SR21-85D

Date	Expiration	Group	No.	Page
08.2023	NA	3521	85	9(34)

- 2) Adjust the four (4) screws until the beam mounting bracket is **26 mm** from panel.

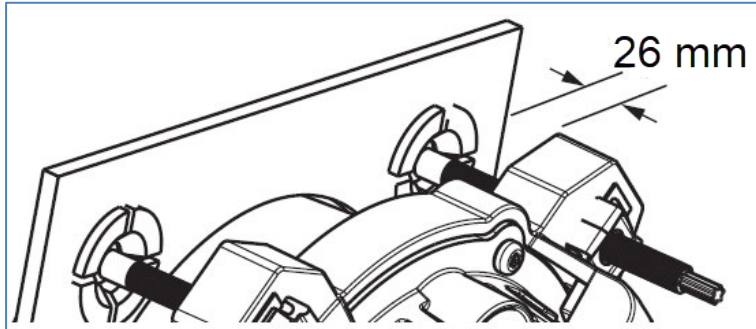

Figure 11

- 3) Plug the high beam connector labelled **E01**.

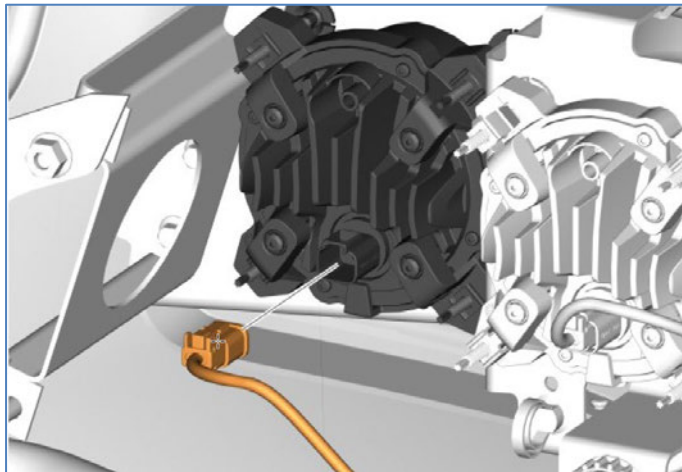

Figure 12

TURN SIGNAL INSTALLATION

- 1) Position the turn signal module in place.

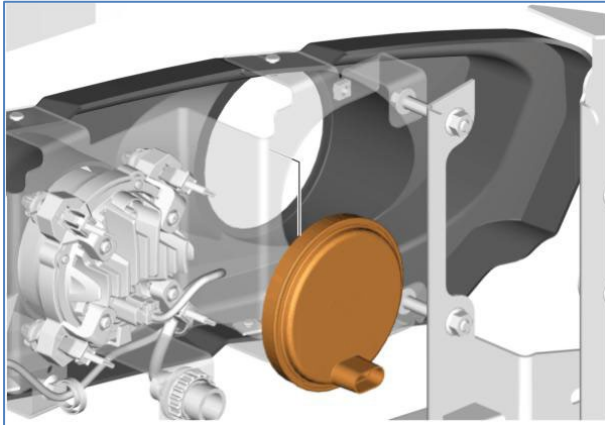

Figure 13: RH headlamp shown

- 2) Plug the turn signal module with labelled **E13**.

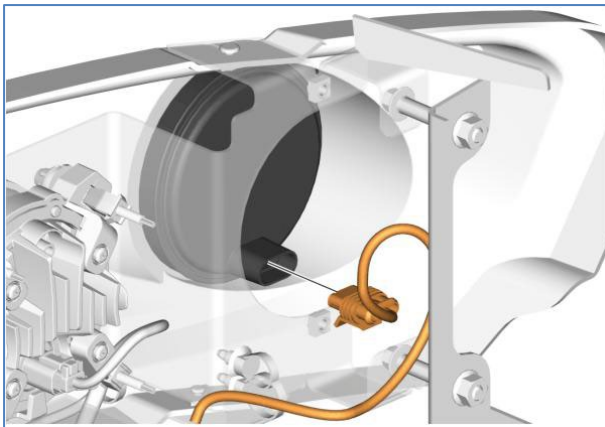

Figure 14: RH headlamp shown

- 3) Install the bracket, the two (2) screws (2 washers per screw) and then tighten.

SAFETY RECALL

SR21-85D

Date	Expiration	Group	No.	Page
08.2023	NA	3521	85	11(34)

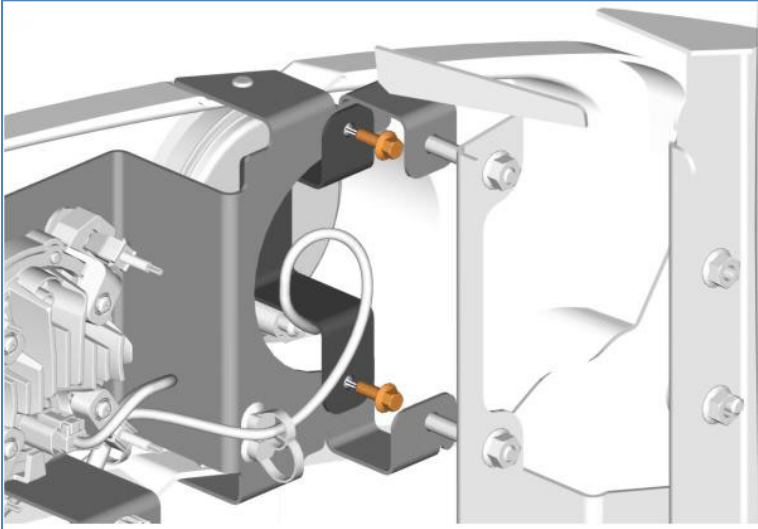

Figure 15: : RH headlamp shown



Figure 16: Two washers per screw

HARNESS INSTALLATION

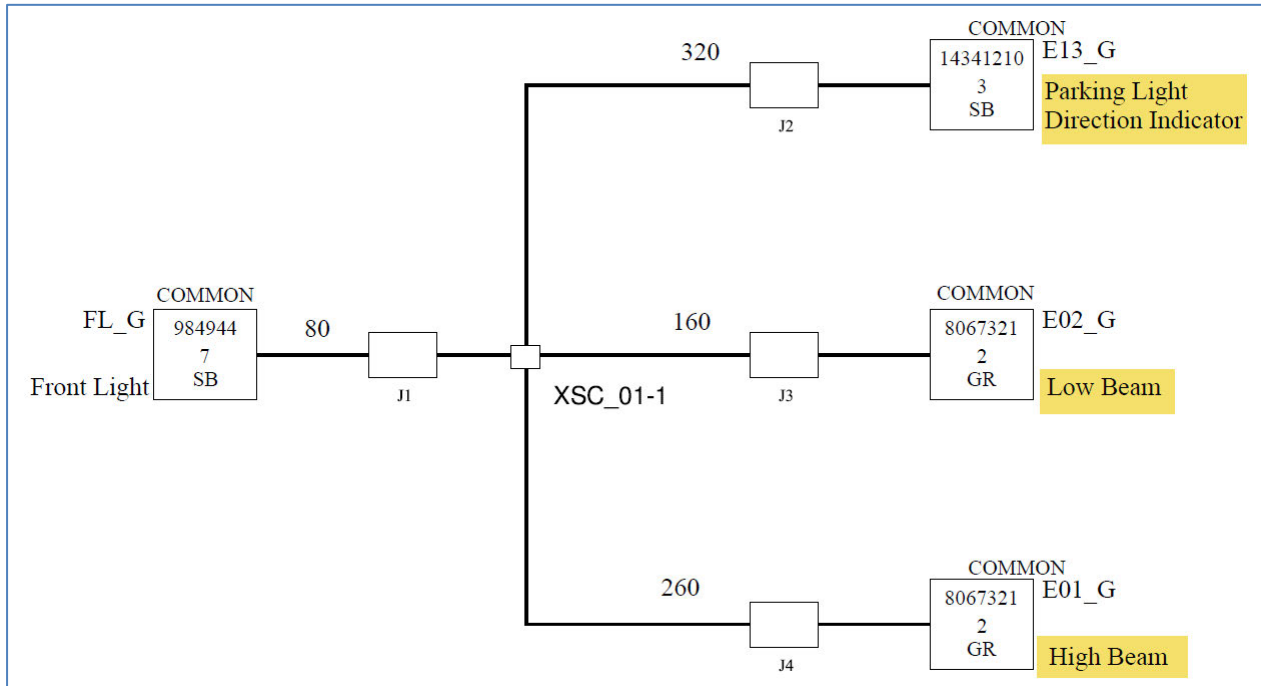

Figure 17

- 1) If not already done, secure the harness using three (3) cable ties as shown the following images.

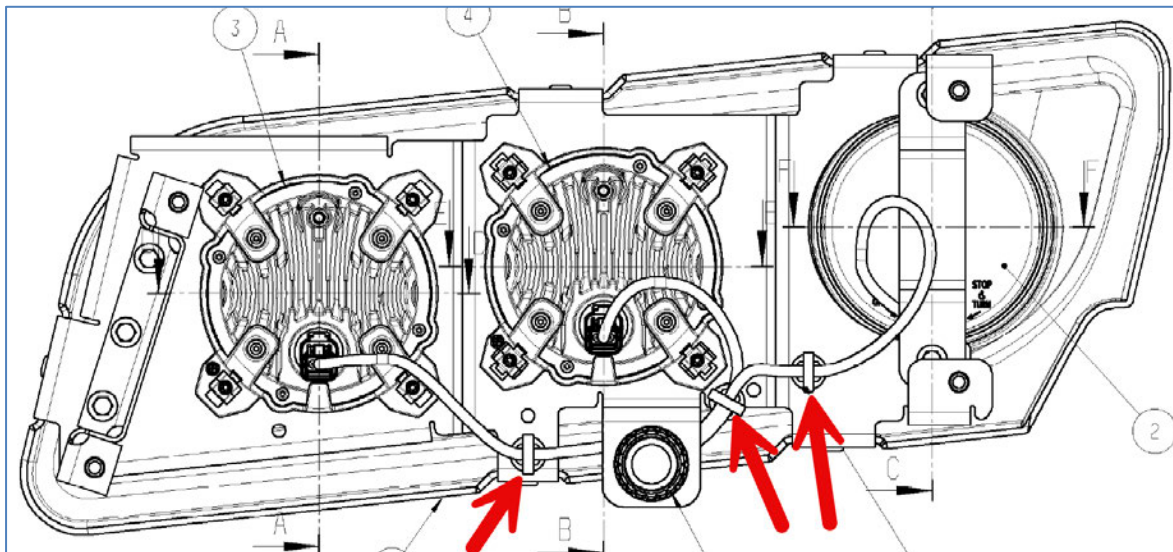

Figure 18: : RH headlamp shown

SAFETY RECALL

SR21-85D

Date	Expiration	Group	No.	Page
08.2023	NA	3521	85	13(34)

- 2) If not already done, secure the connector with the locking ring 3963413.

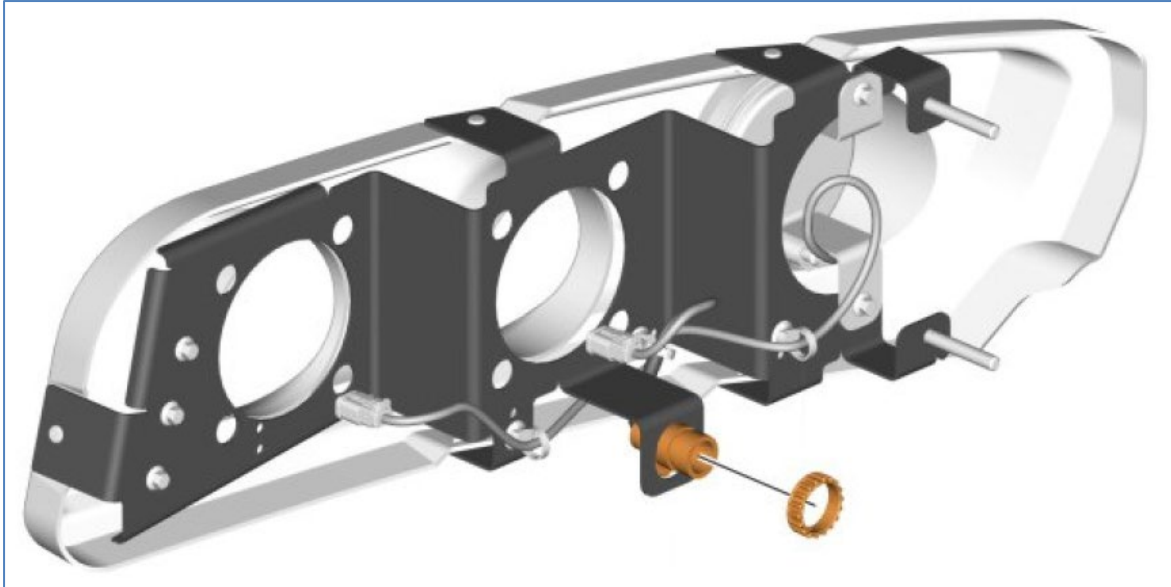

Figure 19: RH headlamp shown

Date	Expiration	Group	No.	Page
08.2023	NA	3521	85	14(34)

GRUPE 1, 2 & 3 VEHICLES - HEADLAMPS REMOVAL & INSTALLATION

- 1) Open the front hatch.

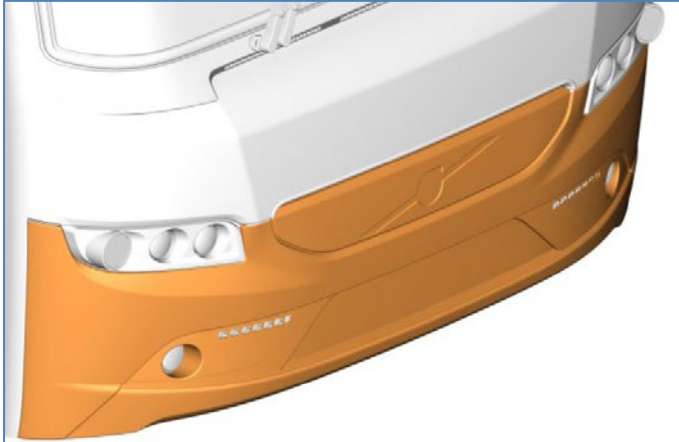

Figure 20

- 2) Loosen the two (2) screws identified in the image below.

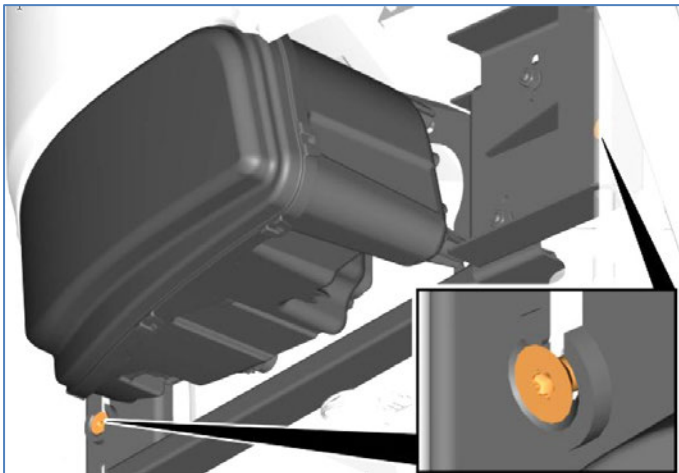

Figure 21

- 3) Lower the headlamp.

SAFETY RECALL

SR21-85D

Date	Expiration	Group	No.	Page
08.2023	NA	3521	85	15(34)

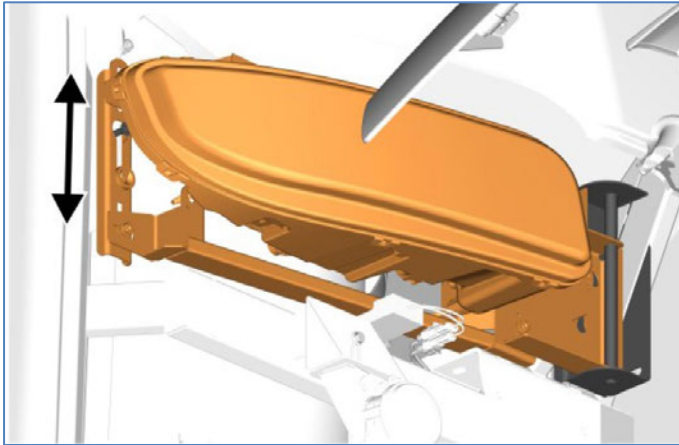

Figure 22

- 4) Swing out the headlamp assembly.

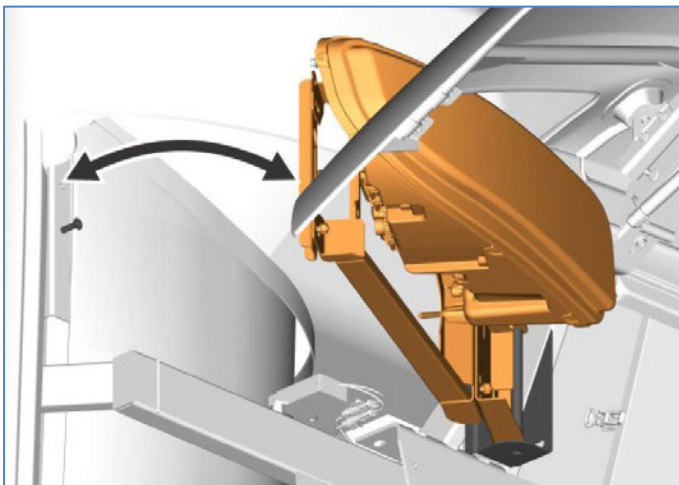

Figure 23

- 5) Disconnect the headlamp wiring harness.

Date	Expiration	Group	No.	Page
08.2023	NA	3521	85	16(34)

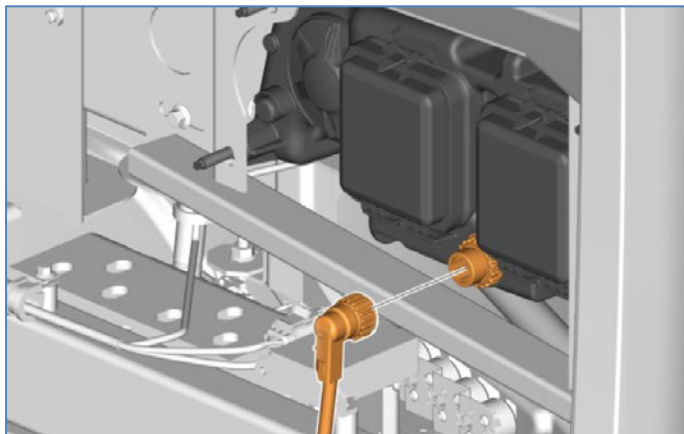

Figure 24

- 6) Remove the headlamp from the support.

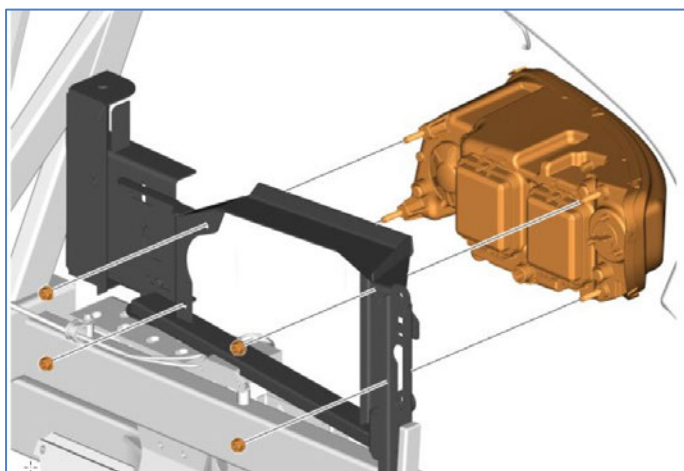

Figure 25

Before installing the new headlamps on the vehicle

SAFETY RECALL

SR21-85D

Date	Expiration	Group	No.	Page
08.2023	NA	3521	85	17(34)

- 7) Check the pre-adjusted **low beam** module height in relation to the mounting plate. The measurement should be **10 mm**. If necessary, adjust using the corresponding adjustment screw.

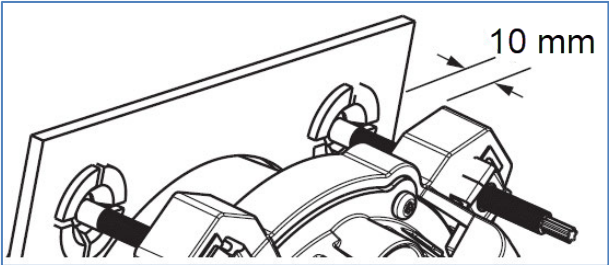

Figure 26

SAFETY RECALL

SR21-85D

Date	Expiration	Group	No.	Page
08.2023	NA	3521	85	18(34)

- 8) Check the pre-adjusted **high beam** module height in relation to the mounting plate. The distance should be **26 mm**. If necessary, adjust using the corresponding adjustment screw.

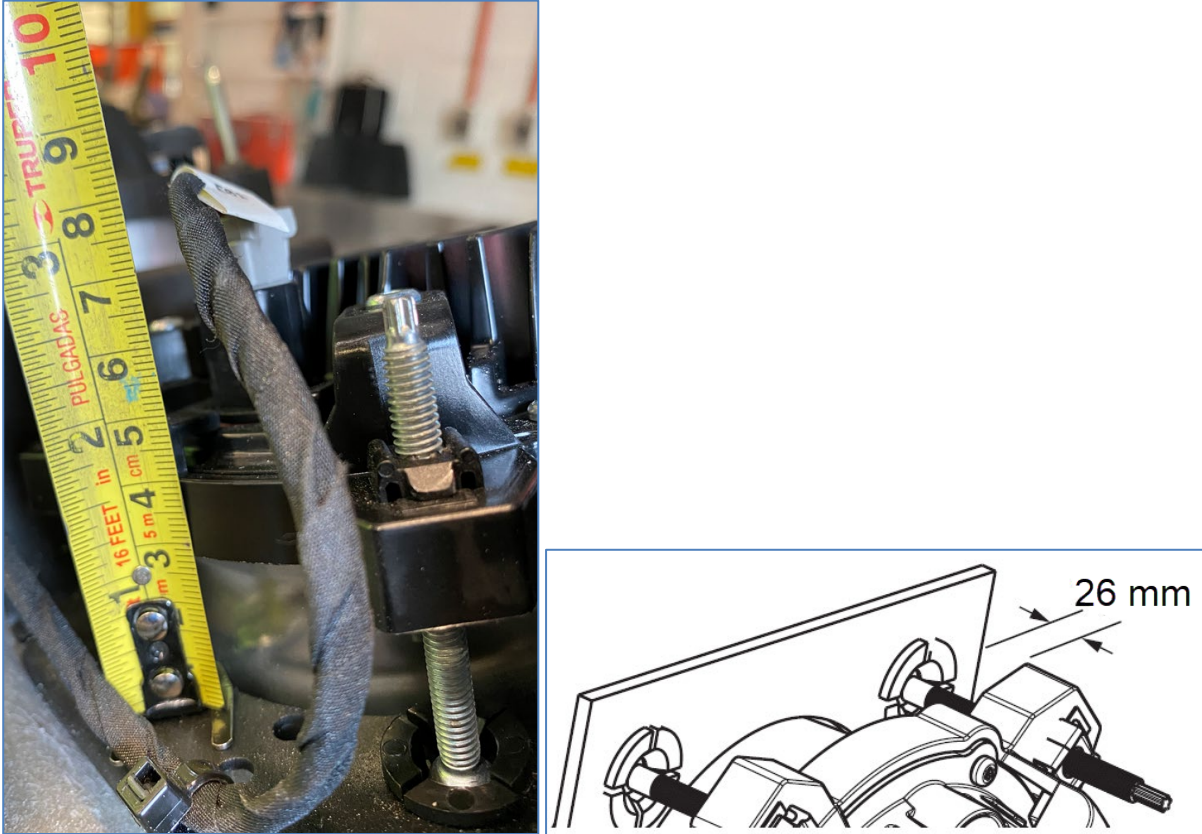

Figure 27

- 9) Check the pre-adjusted measurements of the headlamp unit at the lock nuts. The distance from the bracket base at each fixing screw should be 33 +/- 1 mm.

SAFETY RECALL

SR21-85D

Date	Expiration	Group	No.	Page
08.2023	NA	3521	85	19(34)

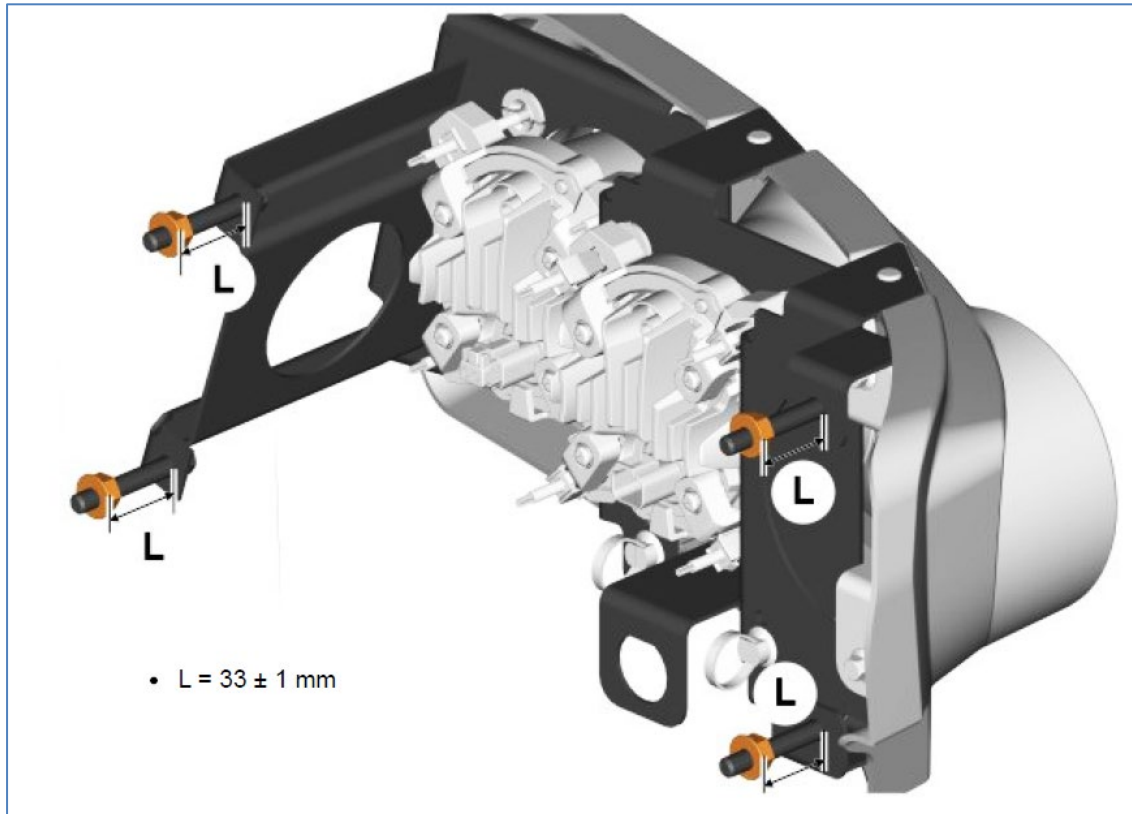

Figure 28

- 10) Install the new front headlamp assembly on the vehicle by screwing the four fixation screws to the body installation bracket. Tighten the headlamp fixation screws to a torque of **28 N-m**.

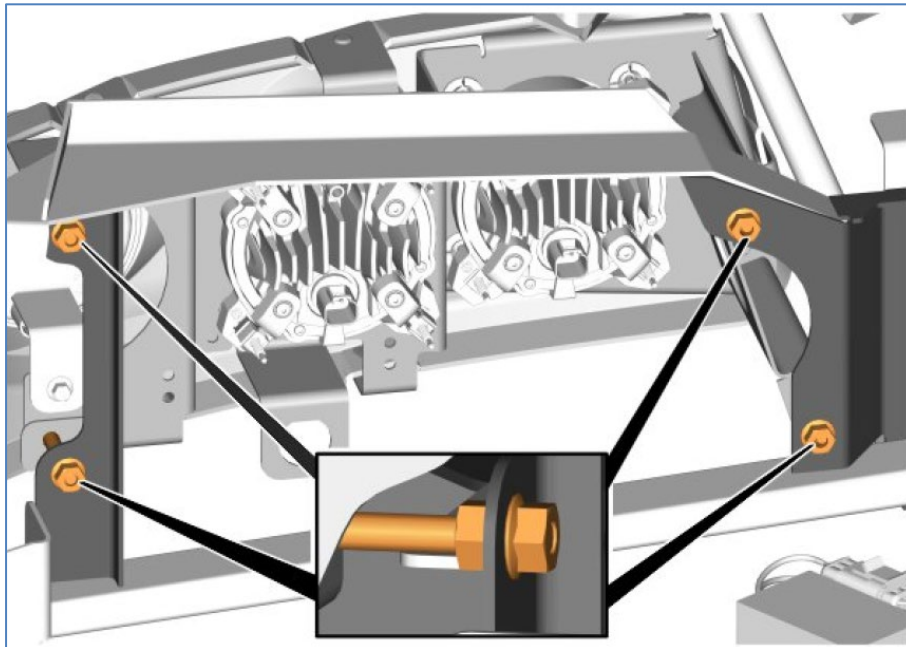

Figure 29

- 11) Plug the headlamp harness connector.

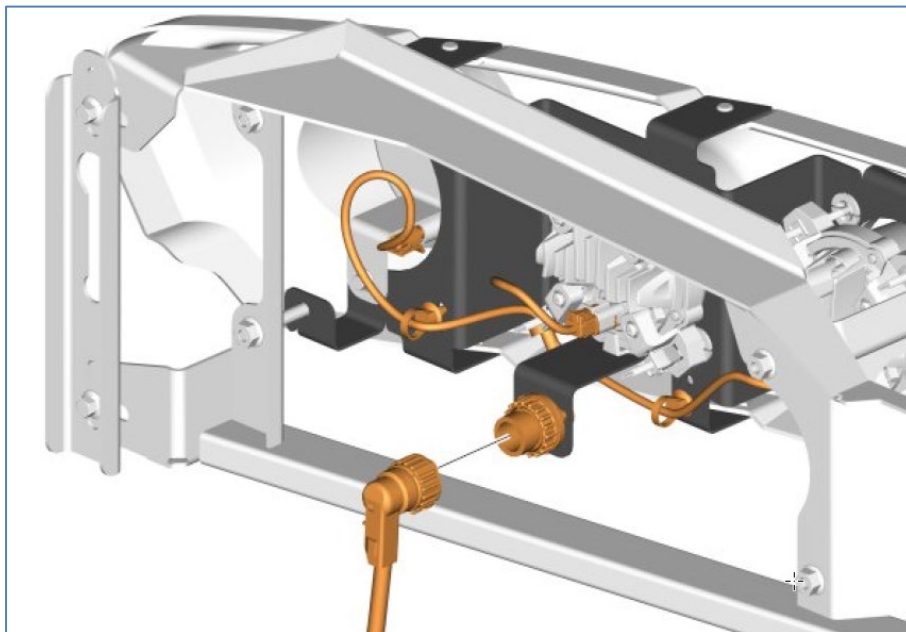

Figure 30

- 12) Close the headlamp and bracket assembly.

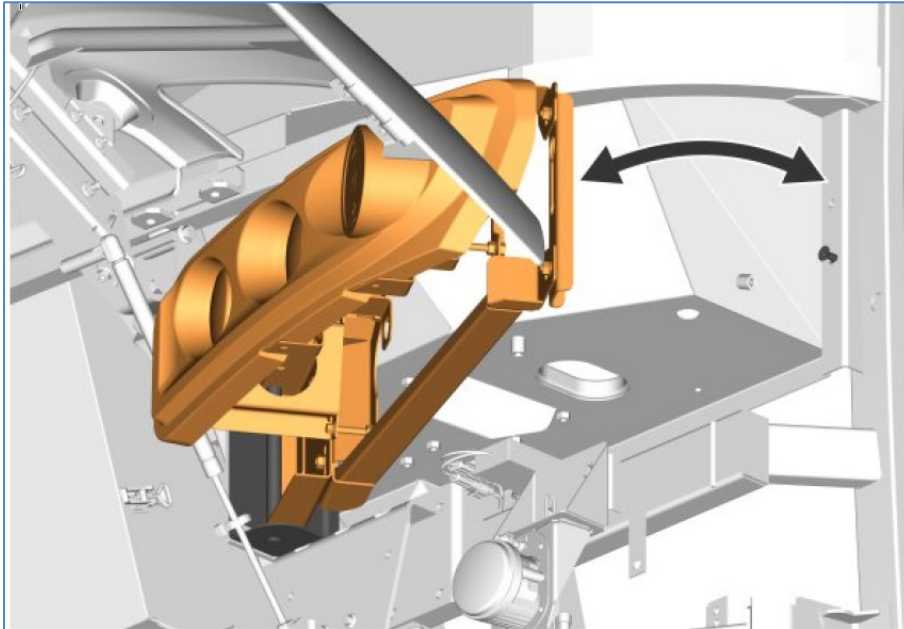

Figure 31

- 13) Raise the headlamp and clip in place.

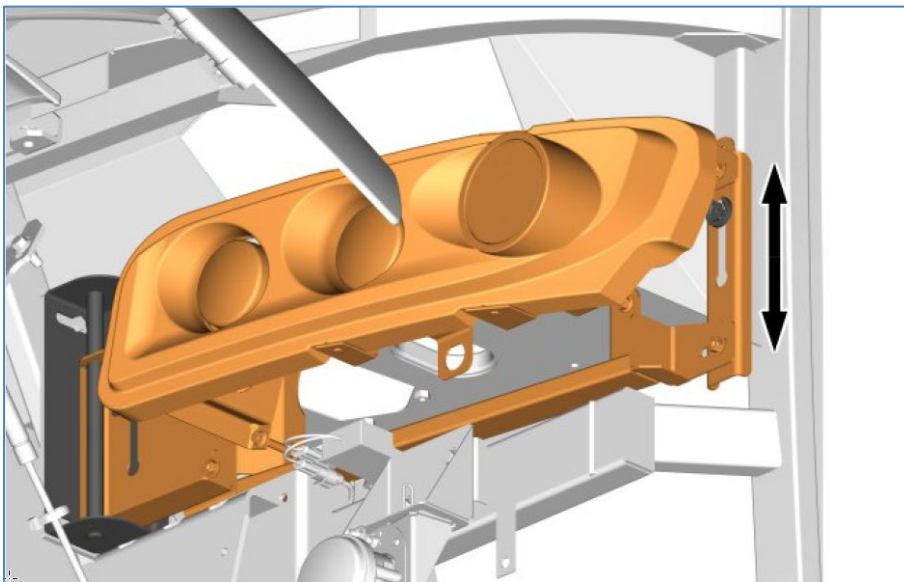

Figure 32

- 14) Fix the headlamp assembly bracket to the coach body structure by screwing its fixing screws. Tighten the headlamp assembly bracket fixing screws to a torque of **54 +/- 4 N-m**.

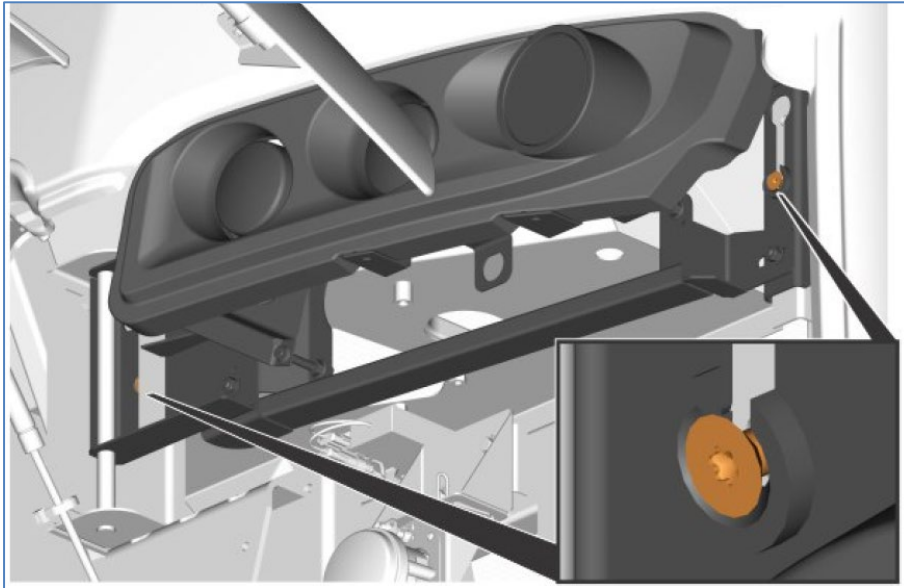

Figure 33

- 15) Close the front hatch and if necessary, adjust the headlamp bezel with the surrounding surfaces of the coach front panel and the bumper. To do so, screw or unscrew the bracket fixing screws locknut, modifying the pre-adjusted measurement of **33 +/- 1 mm** as required.

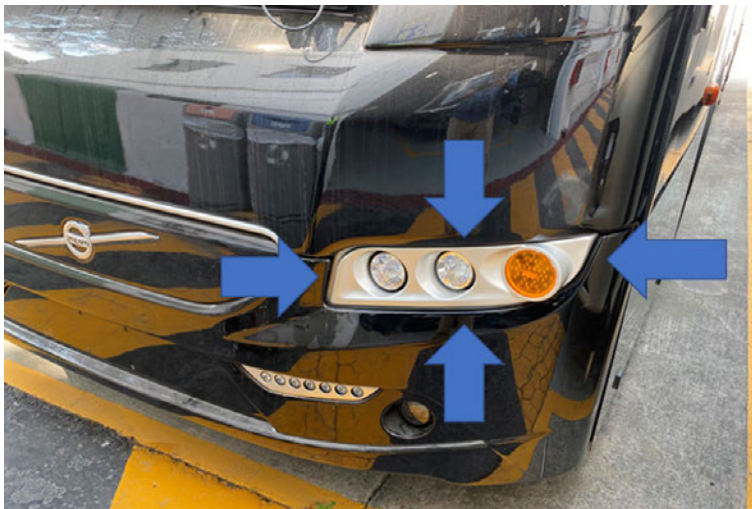

Figure 34

- 16) Verify that the headlamps installation is as show on the image.

SAFETY RECALL

SR21-85D

Date	Expiration	Group	No.	Page
08.2023	NA	3521	85	23(34)

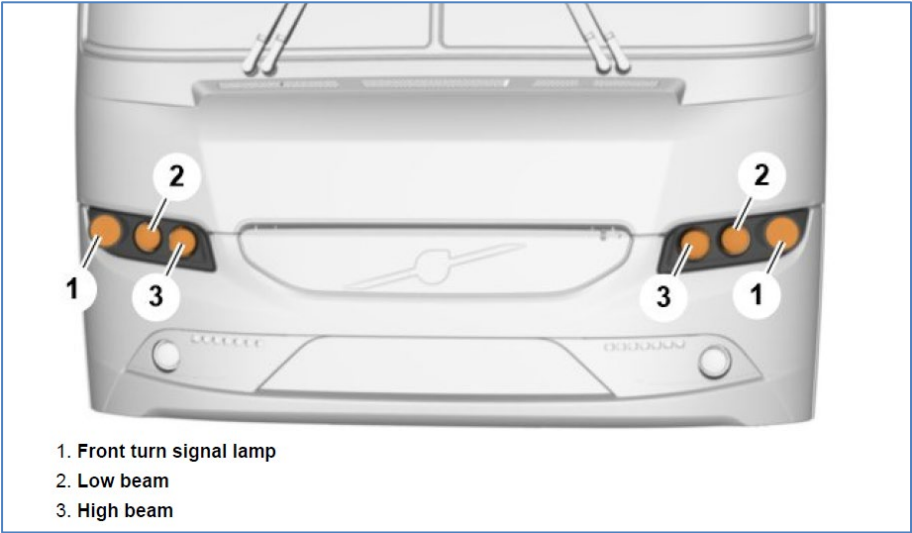

Figure 35

Date	Expiration	Group	No.	Page
08.2023	NA	3521	85	24(34)

GRUPE 1 VEHICLES ONLY - RESISTOR HARNESS INSTALLATION

- 3) In the electrical compartment located on the L.H. side of the entrance, connect both black wires of the resistor harness 7775321 on the ground stud terminal.

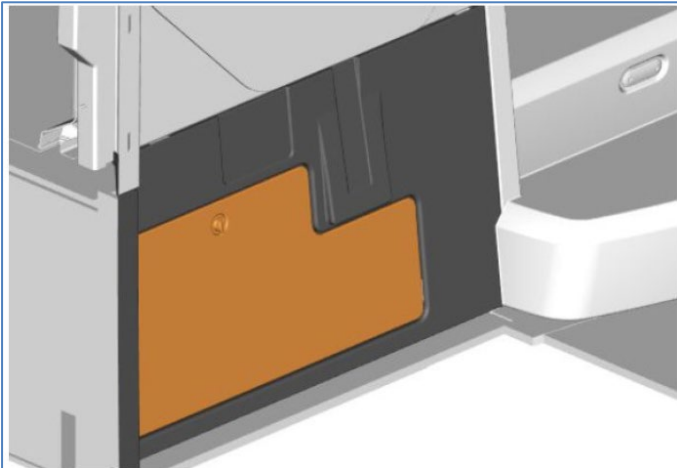

Figure 36



Figure 37

- 4) Locate LCM A27.A connector.

SAFETY RECALL

SR21-85D

Date	Expiration	Group	No.	Page
08.2023	NA	3521	85	25(34)

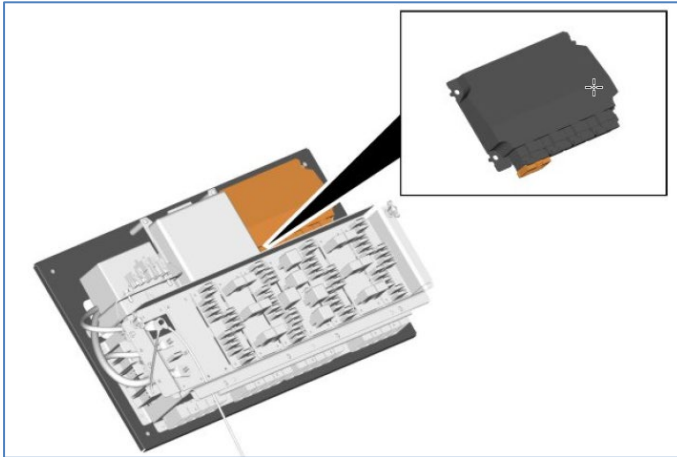

Figure 38

5) On this connector, identify circuits A19 & A20.

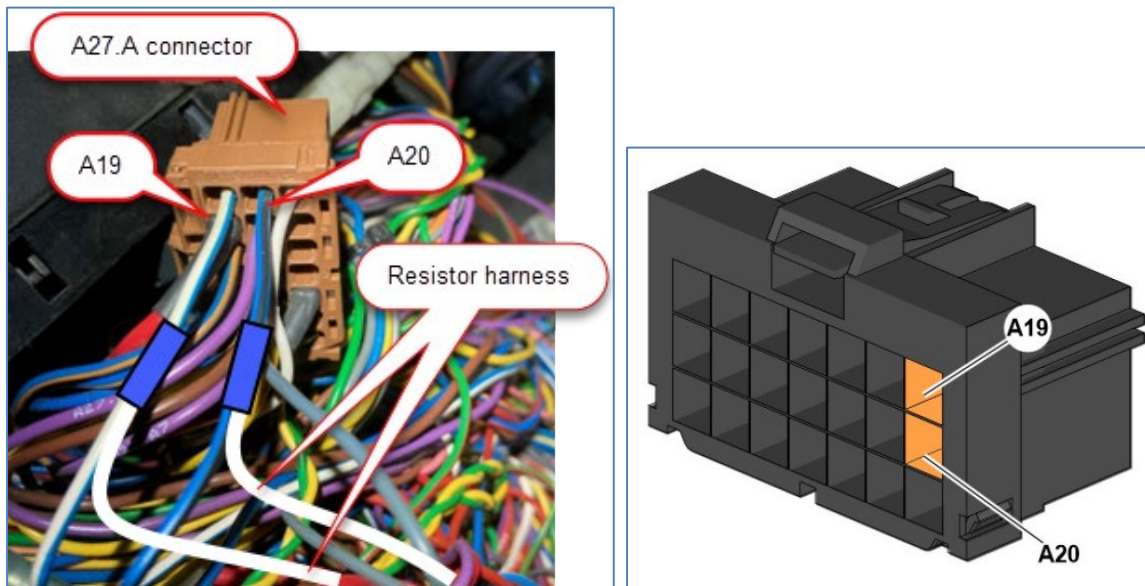

Figure 39

6) Splice one of the white wire of resistor harness with **blue/white** wire (circuit A19) connected at A27.A19.

7) Splice the second white wire of resistor harness with **blue/black** wire (circuit A20) connected at A27.A20.

GRUPE 1, 2 & 3 VEHICLES - HEADLAMPS AIMING INSTRUCTION

- 8) Place the coach on a level surface.
- 9) The suspension must be at normal ride height.
- 10) Place a screen in front of the coach or alternately, place the coach in front of a white wall.

The distance between the front of the coach (at the center) and the screen or wall must be 7.6 meter (25 ft) (see A in Figure 40).

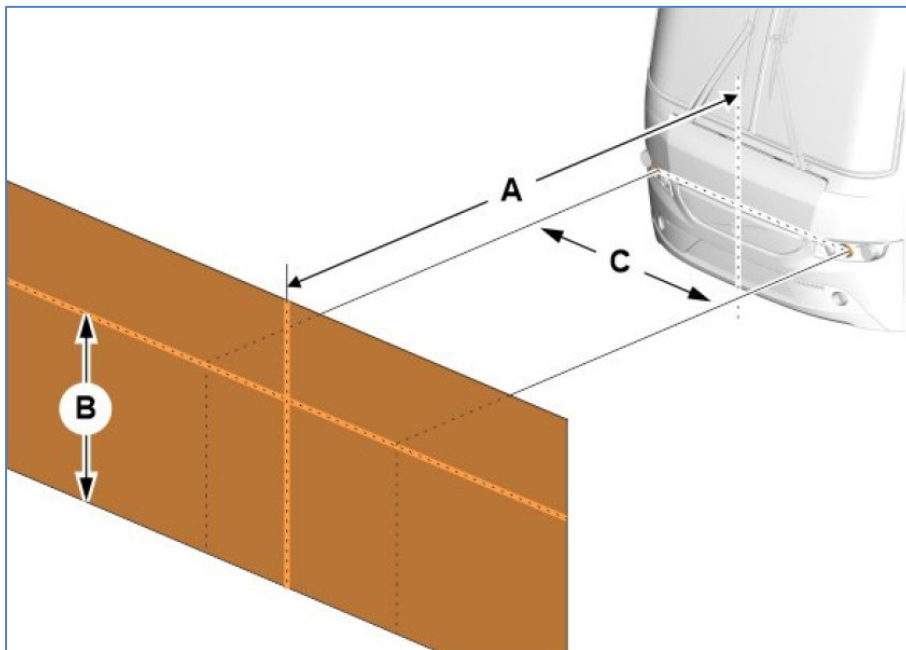

Figure 40

Low Beam Adjustment

- 11) Draw a horizontal line (B) at 940 mm (36.5 in) above the floor level and mark the distance between low beams C: 1875 mm (73.8 in).
- 12) Turn the low beams headlamps on.
- 13) The lens is aimed using the horizontal cutoff line B matching the top edge of the high-intensity zone, to the right of the headlamp's vertical centerline D, use region E to set aim.

Date	Expiration	Group	No.	Page
08.2023	NA	3521	85	27(34)

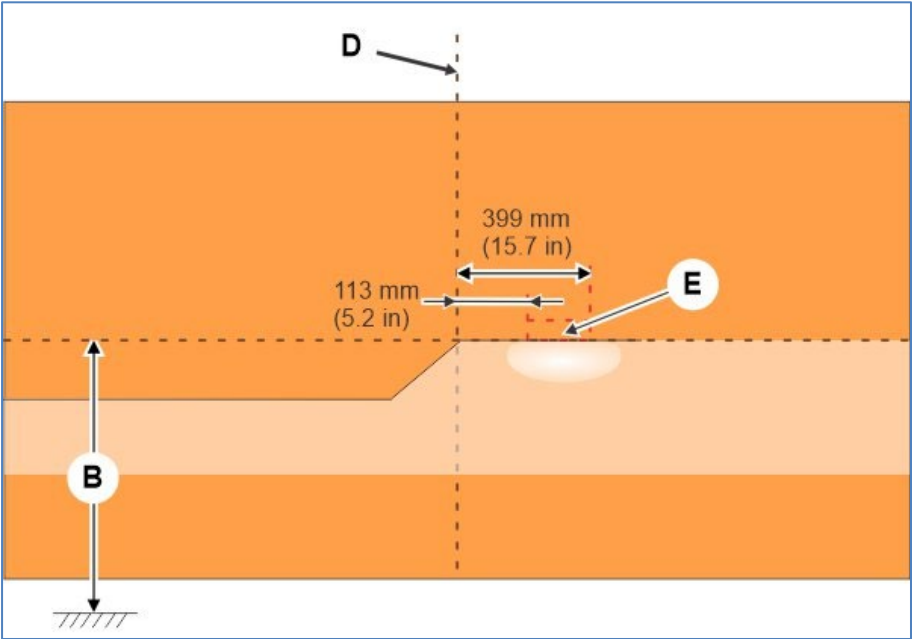

Figure 41

The highest zone of the light beam must be aligned (and touching) with the 940 mm line.



Figure 42: proper low beam height

SAFETY RECALL

SR21-85D

Date	Expiration	Group	No.	Page
08.2023	NA	3521	85	28(34)

14) Use the holes in the bezel to access the adjustment screws.

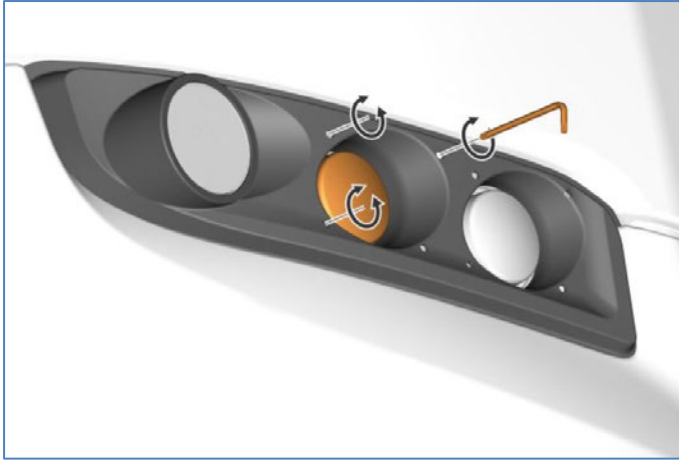

Figure 43

High Beam Adjustment

- 15) Draw a horizontal line **(B)** at 928 mm (above the floor level) and mark the distance between high beams **C**: 1616 mm (73.7 in).

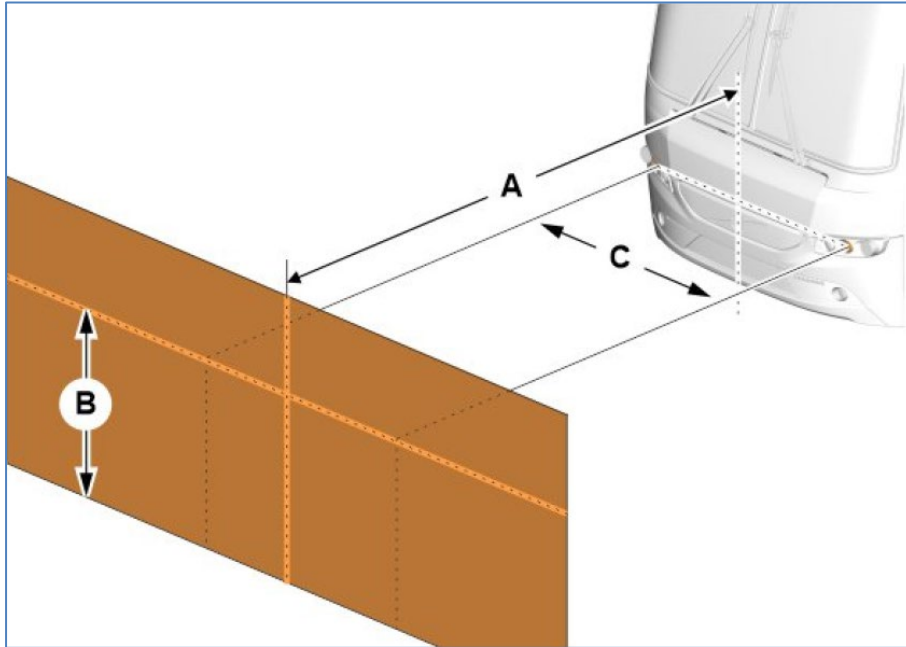

Figure 44

- 16) The lens is aimed using the intersection between the horizontal B cutoff and straight-ahead vertical line of the lens position (L or R) that matching at the center of the high-intensity zone, use the 100 mm area around the intersection to set aim.

Date	Expiration	Group	No.	Page
08.2023	NA	3521	85	30(34)

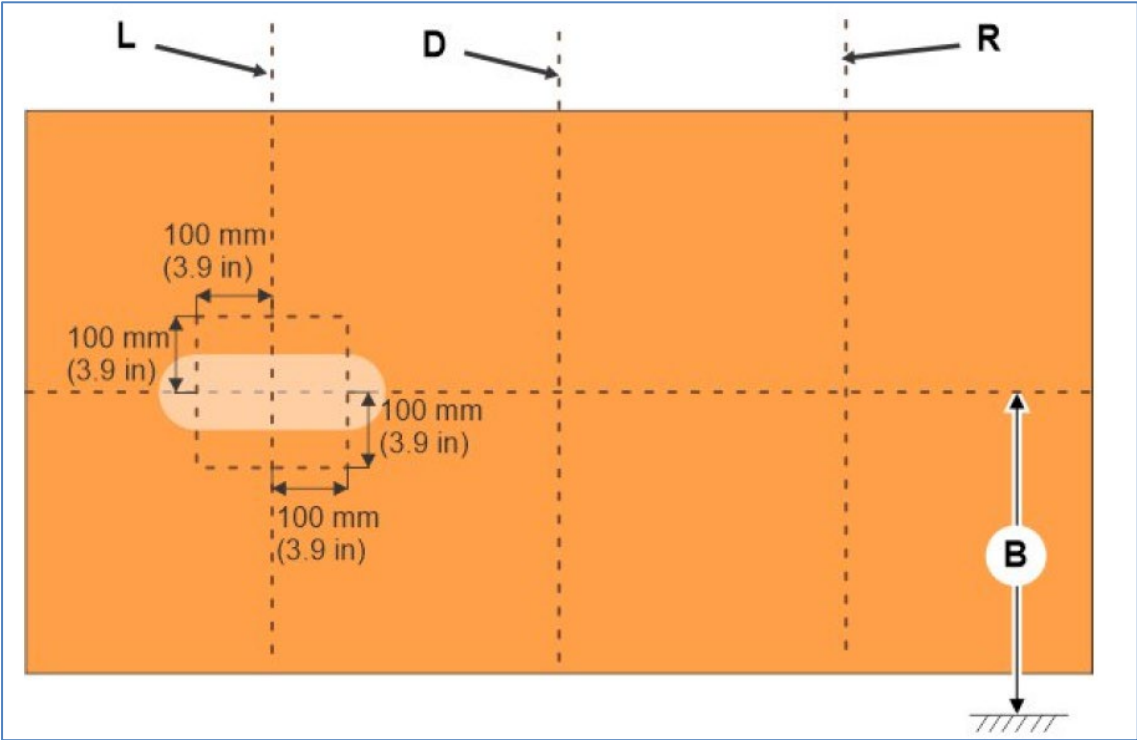

Figure 45

17) Use the holes in the bezel to access the adjustment screws.

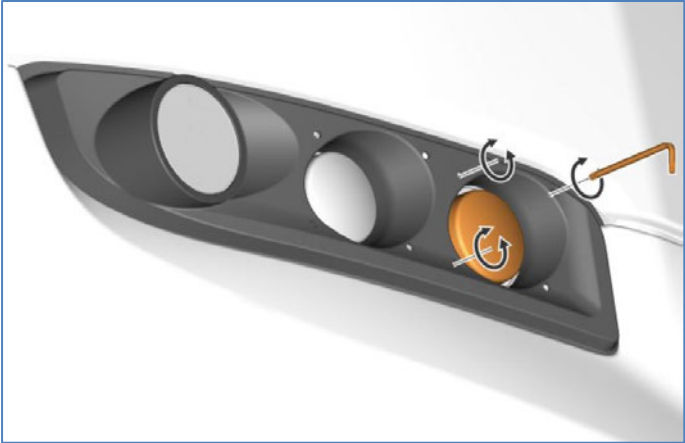

Figure 46

Date	Expiration	Group	No.	Page
08.2023	NA	3521	85	31(34)

GRUPE 2 & 3 VEHICLES - SOFTWARE UPDATE

- 1) Connect PTT (Premium TechTool) to the DCL vehicle connector.

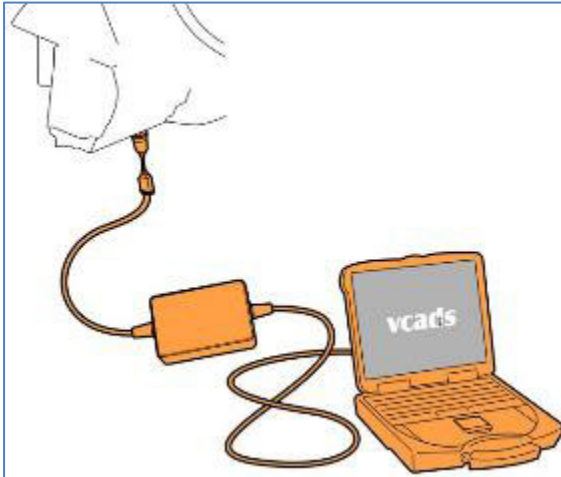

Figure 47

- 2) Run the accessory KIT: **N/P: 24252354**; CONVERSION KIT, SLCM PARAMETERS.
- 3) Order LCM MID 216 software to manage software new.
- 4) Program LCM using storage software.



Figure 48

- 5) Go back to manage new software and return software package.

Date	Expiration	Group	No.	Page
08.2023	NA	3521	85	32(34)

GRUPE 1 VEHICLES ONLY - PARAMETER UPDATE



Figure 49

Connect Premium TechTool. Go to operation Parameter programming. Select / control unit / MID 216. Confirm all parameters below are set to the proper values and change values if needed:

- Parameter AKY Day time driving running light = ON
- Parameter ANJ Low beam left low current detection = Disable
- Parameter ANK Low beam right low current detection = Disable
- Parameter DWO Xenon High beam mode = OFF
- Parameter DWQ DRL CAMP output = Standard
- Parameter DWU Head light high beam left low current = Disable
- Parameter DWV Head light high beam right low current = Disable
- Parameter FHL Low beam Xenon = OFF
- Parameter HXC Campaign Lights = OFF
- Parameter MND Digital output PIN for DRL = 0

Date	Expiration	Group	No.	Page
08.2023	NA	3521	85	33(34)

FINAL STEP – FOG LIGHTS ACTING AS CORNERING LIGHTS

Parameter JRD STATIC CORNER LIGHT allows the fog lights to act as cornering lights.

When the fog lights are OFF and the headlamps are ON, activating the direction indicator stalk turns on the corresponding fog light.

If needed, change parameter as follows:

Parameter value

0 = Static corner light disabled

1 = Static corner light enabled

SAFETY RECALL

SR21-85D

Date	Expiration	Group	No.	Page
08.2023	NA	3521	85	34(34)

PARTS / WASTE DISPOSAL

Replaced headlamps must be returned to Prevest according to the Return Shipping Instructions available on www.prevestcar.com (under service / warranty section) for full reimbursement. A copy of the warranty claim form must be enclosed with the shipment.

WARRANTY

This modification is covered by Prevest's normal warranty. We will reimburse you the parts and labor as follows upon receipt of the parts and a completed A.F.A. Please submit claim via our Online Warranty System, available at www.prevestcar.com (under Service \ Warranty section). Use Claim Type: "Bulletin/Recall" and select "Safety Recall SR21-85".

Group 1 vehicles

3 ¼ hours (3.25 h) of labor

Group 2 & 3 vehicles

2 ¾ hours (2.75 h) of labor

OTHER

VBC Bulletin	C0277
Fail Code	06.05
Defect Code	09
Syst.Cond.	R
Causal Part	21209330

Access all our Service Bulletins on <http://prevostparts.volvo.com/technicalpublications/en/pul.asp> or scan the QR-Code with your smart phone.

E-mail us at technicalpublications_prev@volvo.com and type "ADD" in the subject to receive our warranty bulletins by e-mail.



Prevest engages in a continuous program of testing and evaluating to provide the best possible product. Volvo Bus, however, is not committed to, or liable for updating existing products.